

**CONSTRUCTION AND QUALITATIVE ANALYSIS
OF A SEWN BOAT
OF THE WESTERN INDIAN OCEAN**

**A Thesis
by
ROBERT MARSHALL ADAMS**

**Submitted to the Graduate College of
Texas A&M University
in partial fulfillment of the requirements for the degree of**

MASTER OF ARTS

August 1985

Major Subject: Anthropology

**CONSTRUCTION AND QUALITATIVE ANALYSIS
OF A SEWN BOAT
OF THE WESTERN INDIAN OCEAN**

**A Thesis
by
ROBERT MARSHALL ADAMS**

Approved as to style and content by:

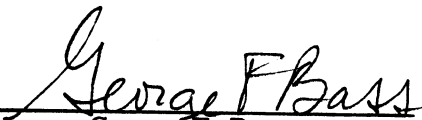
George F. Bass
(Chairman of Committee)

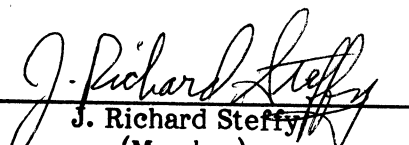
J. Richard Steffy
(Member)

Vaughn M. Bryant, Jr.
(Head, Anthropology)

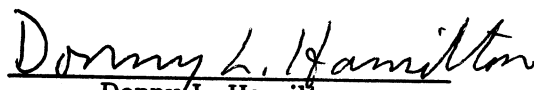
Donny L. Hamilton
(Member)

Peter Hugill
(Member)

August 1985

ABSTRACT

Construction and Qualitative Analysis
of a Sewn Boat of the
Western Indian Ocean. (August 1985)

Robert Marshall Adams, B.A.S., University of Minnesota
Chairman of Advisory Committee: Dr. George F. Bass

For thousands of years the boats that dominated coastal and international trade in the Western Indian Ocean were built entirely without metal fasteners. These carvel, shell-first "sewn boats" were constructed with only cordage for fastenings. When the Portuguese entered the Indian Ocean in the 15th century A.D., sewn-boat construction gave way to western shipbuilding techniques. As a result very little information has been preserved to aid in the definition of the construction of these boats. A relic of these sewn boats of antiquity was the mtepe of the East African littoral, which remained an oddity among the world's vessels until its extinction in the beginning of the 20th century. The mtepe, with its matting sail and extensive decoration is regarded as one of the last of the large sewn vessels of the Western Indian Ocean. Fortunately, nearly a dozen archival photographs and several models of the mtepe have been preserved. These sources, along with previous publications allowed a comparative analysis to define the construction of the mtepe. After definition of the individual construction features is accomplished a qualitative analysis of these components and the boat as a system is presented. Results of the qualitative analysis show that in contrast to the rigidly constructed vessels built in the "western boatbuilding tradition," the sewn hull was designed to be flexible.

ACKNOWLEDGEMENTS

Many people and institutions have been of great assistance in the preparation of this thesis. Unfortunately, they number far more than can be individually acknowledged. To all of those people and institutions, I would like to express my gratitude.

Among those institutions which graciously allowed access to their collections are: National Maritime Museum, Greenwich, England; Science Museum, South Kensington, England; National Archives of Kenya, Nairobi, Kenya; Fort Jesus Museum, Mombasa, Kenya; and the Lamu Museum, Lamu, Kenya.

Several people who were very generous with their time and information include: Mr. and Mrs. Hamo Sassoon, Dr. Ann Spoerry, Mr. John Jewell, and Mr. Neville Chittick. I would like to extend an additional thanks to Espey, Huston & Associates, Inc., Austin, Texas, for their generous support in the production of this thesis. Particular recognition should be given to Mr. Clell Bond and to the personnel of Word Processing for their incredible tolerance and generosity. Individual acknowledgement should be given to Mr. Donald H. Keith for his constructive criticism, to Ms. Candace Kiene for her grammatical and editorial skills and Mrs. Deborah Cassell for her professionalism and perseverance in the final corrections.

I would also like to express my sincere thanks to the staff and spouses of the Institute of Nautical Archaeology for providing me with numerous opportunities to gain experience in the field, with a special note of appreciation to Dr. George F. Bass and his wife Ann, who were fundamental to my early perceptions of nautical archaeology.

A special thanks should go to Mr. and Mrs. R. C. M. Piercy, who not only provided the experience of excavating a Portuguese shipwreck and allowed me time to conduct my research, but also furnished elephants and a solar eclipse, and extended unmatched hospitality.

DEDICATION

To my Family of Friends

For their years of patience, tolerance, friendship
and the enormity that it entails.

TABLE OF CONTENTS

	Page
ABSTRACT	iii
ACKNOWLEDGEMENTS	iv
DEDICATION	v
TABLE OF CONTENTS	vi
LIST OF FIGURES	vii
INTRODUCTION - METHODOLOGY	3
SOURCE REVIEW	9
HULL CONSTRUCTION	31
CONSTRUCTION AND ANALYSIS OF THE MAST ASSEMBLY,	56
SAIL, AND RIGGING	
HULL ANALYSIS	69
PENTHOUSE CONSTRUCTION	78
CONSTRUCTION AND ANALYSIS OF THE RUDDER ASSEMBLY	81
CONCLUSION	91
REFERENCES	93
APPENDIX	
1 Spellings of <u>Mtepe</u>	99
VITA	100

LIST OF FIGURES

	Page
Figure 1.	4
Geographic limits of research area.	
Adapted from Gideon S. Were, <u>East Africa Through a Thousand Years: A History of the Years A.D. 1000 to the Present Day</u> , Africana Publishing Corp., New York, 1968.	
Figure 2.	5
The Western Indian Ocean, showing trade routes & winds.	
Adapted from Gideon S. Were, <u>East Africa Through a Thousand Years: A History of the Years A.D. 1000 to the Present Day</u> , Africana Publishing Corp., New York, 1968.	
Figure 3.	7
The East African coast, showing where the <u>mtepe</u> was constructed and its trade area.	
Figure 4.	14
"Dau la mtepe from Lamu", Fig. 46, p. 83 in Stuhlmann, <u>Handwerk und Industrie im OstAfrika</u> , 1910.	
Figure 5.	17
"Mtepe from Lamu. Rigged Model 1936-19". Broadside 8349. Science Museum, South Kensington, England.	
Figure 6.	18
"Detail of Mtepe from Lamu. Rigged Model 1936-19" Port Quarter 8350. Science Museum, South Kensington, England.	
Figure 7.	19
"Drawing of <u>dau la mtepe</u> ", Fig. 102. (da G. Corni, Somalia Italiana, 1937) - from Grotanelli, <u>Pescatori Dell 'Oceano Indiano</u> , Rome, 1955.	
Figure 8.	21
"Dhow-Mtepe - presented by Commander W. G. Murphy-King" - Fort Jesus Museum, Mombasa, Kenya.	
Figure 9.	22
" <u>Dau la mtepe</u> model - Fort Jesus Museum, Mombasa, Kenya..	
Figure 10.	24
"Bajun Mtepe - made for Sir Mbarak bin ali Hinawi" - Fort Jesus Museum, Mombasa, Kenya.	
Figure 11.	25
"A mtepe", Fort Jesus Museum, Mombasa, Kenya.....	
Figure 12.	27
"Mtepe at Tanga, Tanzania 1895", Vol. 294, Hollis..... papers, Rhodes House, Oxford; located by Hamo Sassoon.	
Figure 13.	28
"Mtepe - donated by Dr. Ann Spoerry" - Lamu Museum, Lamu, Kenya.	

	Page
Figure 14.	"Dau la mtepe - unriggered - B5081", National Maritime Museum, Greenwich, England. 29
Figure 15.	"Mtepe, B5082:, National Maritime Museum, Greenwich, England. 30
Figure 16.	Separated planks showing dowel tenon. 33
	"Bajun Mtepe - made for Sir Mbarak bin ali Hinawi", Fort Jesus Museum, Mombasa, Kenya.
Figure 17.	Correction of dowel tenon and pegging procedure 34 from Prins (1965) :120).
Figure 18.	Pouring pitch into planking seam as part of caulking 35 procedure.
	N. H. Chittick, "Sewn boats in western Indian Ocean and a survival in Somalia", <u>IJNA</u> 9 (1980) 301.
Figure 19.	Schematic of sewing procedure as viewed from interior 37 of hull.
Figure 20.	Juncture of keel and sternpost. 39
Figure 21.	Male-female scarf of stem post. 39
	"Dhow-Mtepe - presented by Commander W. G. Murphy-King", Fort Jesus Museum, Mombasa, Kenya.
Figure 22.	Juncture of keel and sternpost. 40
	"Bajun Mtepe - made for Sir Mbarak bin ali Hinawi on loan from Municipality of Mombasa" (dau la mtepe), Fort Jesus Museum, Mombasa, Kenya.
Figure 23.	Stitches at apex of stern. 41
	"Bajun Mtepe - made for Sir Mbarak bin ali Hinawi", Fort Jesus Museum, Mombasa, Kenya.
Figure 24.	"Close up of hull planking of <u>dau la mtepe</u> " - 43 photo by R. C. Gilfillian Esq., Fort Jesus Museum, Mombasa, Kenya.
Figure 25.	Interior components - Frames, stringer, and partial desk. 44
Figure 26.	Forwardmost arched thurbeam. 44
	"Dhow-Mtepe - presented by Commander W. G. Murphy-King", Fort Jesus Museum, Mombasa, Kenya.

	Page
Figure 27.	"Two <u>dau la mtepe</u> 's at low tide in Mombasa Harbor", 45 Fort Jesus Museum, Mombasa, Kenya.
Figure 28.	"Aft portion of <u>dau la mtepe</u> 1917", photo by 46 R. C. Gilfillian Esq., Fort Jesus Museum, Mombasa, Kenya.
Figure 29.	"Several <u>Mtepes</u> at anchor", from an album of 47 Ron H. K. _____ (1875-1923), CMS missionary in Mombasa, Freretown & Rabai, Fort Jesus Museum, Mombasa, Kenya.
Figure 30.	Detail of frame scarf pattern forward of amidships. 48 "Bajun Mtepe - made for Sir Mbarak bin ali Hinawi", Fort Jesus Museum, Mombasa, Kenya.
Figure 31.	Stitching pattern used to secure frames forward of amidships.. 49 "Bajun Mtepe - made for Sir Mbarak bin ali Hinawi", Fort Jesus Museum, Mombasa, Kenya.
Figure 32.	Stitching pattern used to secure stringers..... 51 "Dhow-Mtepe - presented by Commander W. G. Murphy-King", Fort Jesus Museum, Mombasa, Kenya.
Figure 33.	Position of stringers in hull. 51 "Bajun Mtepe - made for Sir Mbarak bin ali Hinawi", Fort Jesus Museum, Mombasa, Kenya.
Figure 34.	Cross-section of hull..... 52
Figure 35.	Sewing pattern of external caulking..... 53 "Bajun Mtepe - made for Sir Mbarak bin ali Hinawi", Fort Jesus Museum, Mombasa, Kenya.
Figure 36.	"Gammoning" lashing between thwarts. 55 "Dhow-Mtepe - presented by Commander W. G. Murphy-King", Fort Jesus Museum, Mombasa, Kenya.
Figure 37.	Mast step incorrectly identified as keelson, 57 Prins (1965):188.
Figure 38.	Mast assembly showing "gammoning" lashing. 59 "Dhow-Mtepe - presented by Commander W. G. Murphy-King", Fort Jesus Museum, Mombasa, Kenya.

	Page
Figure 39.	Mast assembly..... 60
Figure 40.	Qualitative vector analysis of forces exerted on vessel..... 61 while sailing.
Figure 41.	Photograph and schematic of method used to secure shrouds, . 63 from Prins (1965):120.
	"Bajun Mtepe - made for Sir Mbarak bin ali Hinawi on loan from Municipality of Mombasa" (dau la mtepe), Fort Jesus Museum, Mombasa, Kenya.
Figure 42.	Mtepe without sheets or shrouds..... Map Pocket
Figure 43.	Plaiting strips of palm fiber. 65
Figure 44.	"Dau la mtepe under sail 1917", photo by 66 R. C. Gilfillian Esq., Fort Jesus Museum, Mombasa, Kenya.
Figure 45.	"Dau La Mtepe, as seen at Mombasa Old Port 67 in the early 1920's", John Jewell, <u>Dhows at Mombasa</u> , p. 77.
Figure 46.	Canted stitching between keel and garboard near stern. 71
	"Dhow-Mtepe - presented by Commander W. G. Murphy-King", Fort Jesus Museum, Mombasa, Kenya.
Figure 47.	Schematic of torsional movement of stem post..... 73
Figure 48.	"Dau la mtepe at low tide", Fort Jesus Museum, 76 Mombasa, Kenya.
Figure 49.	"Dau la Mtepe at anchor in Old Mombasa Harbour", 79 from John Jewell, <u>Dhows at Mombasa</u> , p. 76.
Figure 50.	Rudder on <u>mtepe</u> model. 82
	"Bajun Mtepe - made for Sir Mbarak bin ali Hinawi", Fort Jesus Museum, Mombasa, Kenya.
Figure 51.	Differences between the <u>mtepe</u> and <u>dau la mtepe</u> 83 rudder assemblies.
Figure 52.	Small rudder hung with simple coir fiber grommets, 84 from Chittick, <u>IJNA</u> 9, p. 301.
Figure 53.	Rudder and aft portion of <u>dau la mtepe</u> " - photo by 86 R. C. Gilfillian Esq., Fort Jesus Museum, Mombasa, Kenya (rudder assembly)
Figure 54.	Rudder assembly showing location of effective center 88 of mass when tassle is added.

PREFACE

During my first class at Texas A&M University my attention was drawn to the Red Sea during a seminar in Pre-Classical Seafaring, conducted by Dr. George F. Bass. The seminar focused on the amount and type of seafaring that may have occurred in earliest dynastic Egypt. The conclusion was that seafaring in some form probably took place but that information to answer many specific questions was unavailable. Very little is known about early seafaring in this area.

The following semester, in a course taught by Mr. J. Richard Steffy, I endeavored to study the merchant vessels that transported trade items throughout the Indian Ocean for thousands of years. As a result, I found that before the arrival of the Portuguese in 1497, the dominant vessels were boats that were collectively termed "sewn" vessels. These vessels were plank-built and utilized coir, stitching manufactured from coconut husks, for their fastenings. This fact, along with an attempt to extrapolate those features of ancient origin present on modern vessels, led to a highly hypothetical design with few specific details of the construction of a pre-Portuguese contact vessel.

During the winter of 1980 I had the opportunity to participate in the Institute of Nautical Archaeology and National Museums of Kenya - Mombasa Wreck Excavation in Mombasa, Kenya, directed by Mr. R. C. M. Piercy. During the excavation, I was able to examine closely the replica models of the mtepe, the last of the larger sewn vessels to ply the East African coast. These models, housed at the Fort Jesus Museum in Mombasa, enabled me to examine first-hand, in three dimensions, details of the construction of a sewn vessel. Not only was I able to examine the exteriors, but also the interiors of the models, which are rarely described or illustrated. In addition to having three of nine known models immediately at hand, I had access to a fourth model located at the museum in Lamu, approximately 150 miles to the north. These models, along with several archival photographs at Fort Jesus that had not previously been available as resources, provided a unique opportunity to define clearly the construction of this sewn vessel type, which has many parallels to the sewn vessels of antiquity.

After my return to College Station my research revealed many fascinating aspects of the mtepe. Among them were its use in trade, its cultural origins, and the stages resulting in its extinction. All of these aspects were very interesting but were overshadowed by its unique construction, so different from vessels built in the "western boat-building tradition."

In this thesis I will first define the construction of the mtepe. With a definition of its individual components this sewn boat can then be studied as a system. The overall picture of the vessel and the interaction of its components reveal a fundamental concept in its design. It is a concept based on a vessel's being constructed to be flexible.

INTRODUCTION - METHODOLOGY

The term "sewn" boat is very broad. For the purpose of this thesis, a sewn boat is defined as a vessel that uses cordage for fastening, with no metal fasteners present. Vessels fitting these criteria were used throughout the history of seafaring in widely divergent geographical areas. This simple classification would include vessels from South Pacific canoes to papyrus rafts to the Hjortspring boat, but here we will focus on only one geographic area, the Western Indian Ocean, and define one sewn boat type within that area.

This trade area is defined by geographic and climatological factors. Its geographic limits are clearly delineated to the southwest by the treacherous waters of the Cape of Good Hope, and to the southeast by the tip of India (Fig. 1).

The climatological factor that was, and continues to be, of extreme importance in seafaring as well as to commerce throughout the Western Indian Ocean is the monsoon winds. These winds blow steadily from the northeast for four months of the year and reverse during summer months to blow from the southwest. Their reliable cyclical shift not only determined when ships left port but also controlled the shipment of goods from the interior to coastal trade centers (Martin, 1978:76) (Fig. 2).

The reliability of the winds encouraged distant trading ventures. These long trips, which involved lengthy stints in foreign ports to acquire trade items and wait for the wind to shift, most assuredly led to a hybridization of ship design over the thousands of years of international trade.

Within this geographic area, we will further narrow the choice of a vessel to be studied by the stipulation that it should be capable of open-ocean voyaging. Papyrus and papyriform hulls capable of open-ocean sailing appear in early records and depictions. Indeed, these hull forms may have been predecessors of later plank-built seafaring sewn boats, and there may well have been an evolution from one hull type to the other. For the terms of this thesis, however, the distinct stem, keel, and sternpost style of construction has been selected for study because it appears to have been designed for open water sailing. This choice eliminates those papyrus and papyriform vessels used primarily as rivercraft by the Egyptians and Mesopotamians.

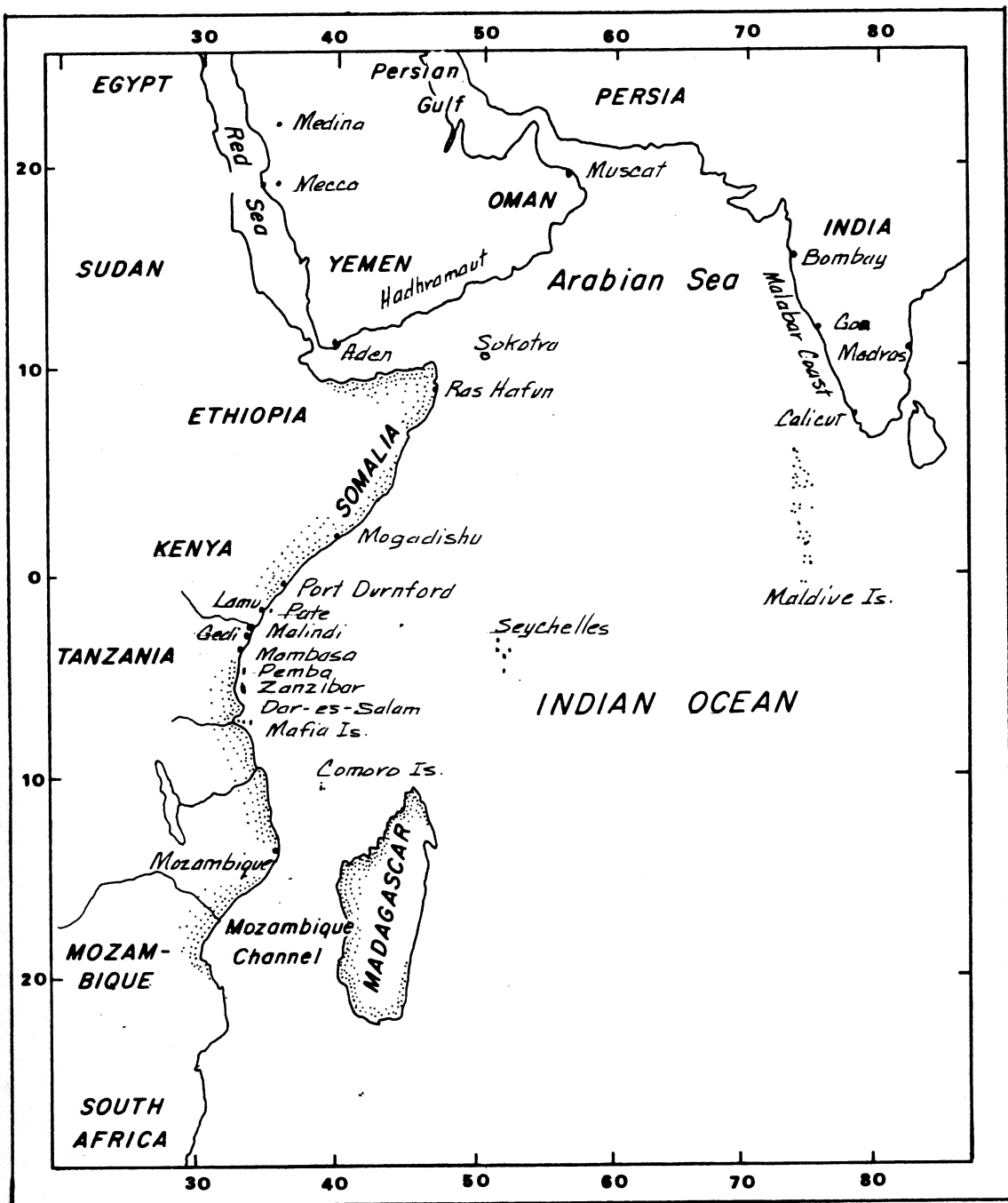

Figure 1. Geographic limits of research area.

Adapted from Gideon S. Were, East Africa Through a Thousand Years: A History of the Years A.D. 1000 to the Present Day, Africana Publishing Corp., New York, 1968.

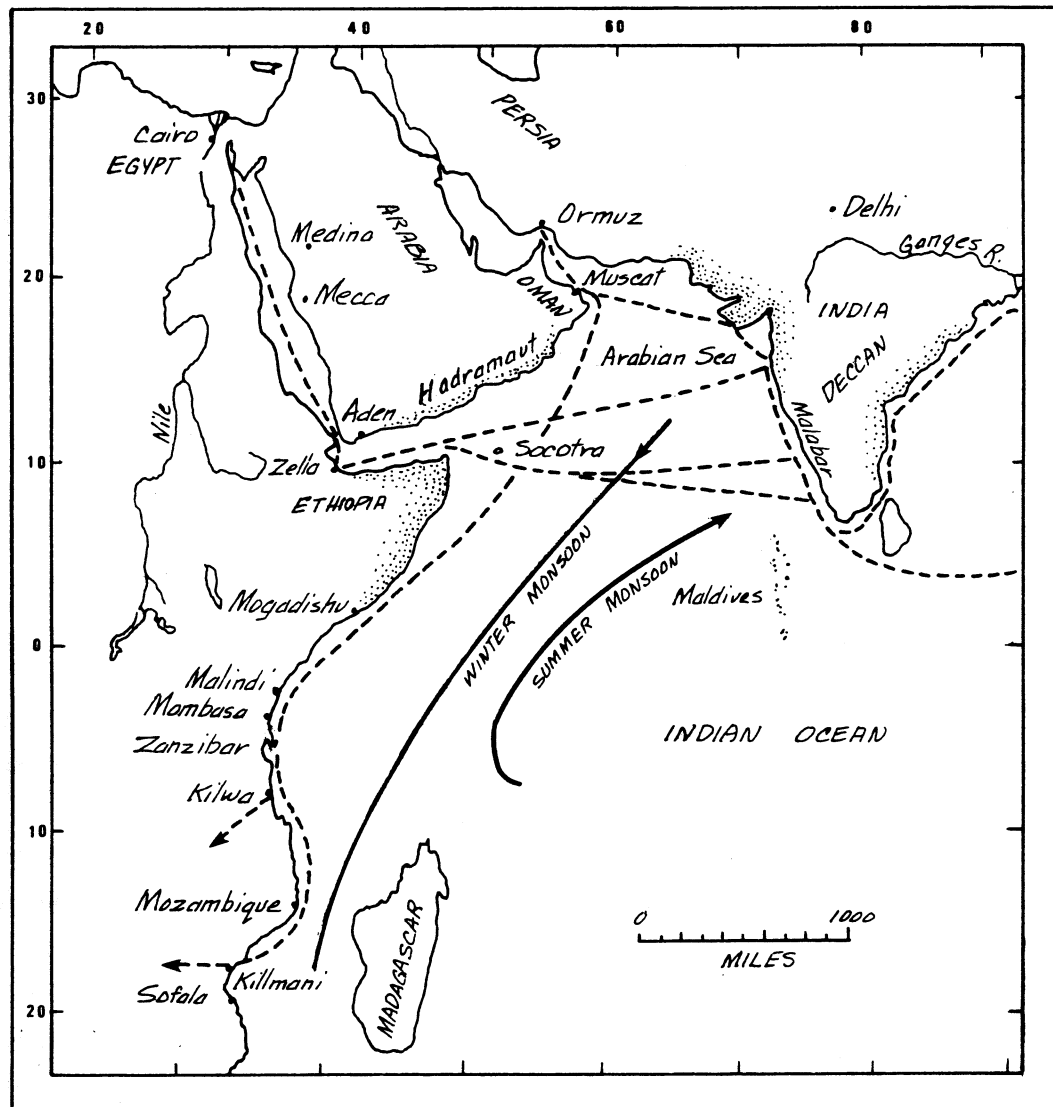

Figure 2. The Western Indian Ocean, showing trade routes & winds.

Adapted from Gideon S. Were, East Africa Through a Thousand Years: A History of the Years A.D. 1000 to the Present Day, Africana Publishing Corp., New York, 1968.

Although these preceding restrictions appear to be severely limiting, they do not eliminate the plank-built sewn vessels that were primarily responsible for international and coastal trade throughout the Western Indian Ocean for at least a thousand years.

The sources available for understanding these boats were divided into four categories, with several subdivisions. Literary sources are those written references which pertain either to first-hand observations of the vessel type or to academic discussion, such as those dealing with secondary references. Depictions comprise the second source category, which is subdivided into four subjects: drawings, photographs, reliefs, and models. Archaeological examples compose the third category, and the fourth groups the remaining relatives, including those vessels which have remnant characteristics of sewn boats.

Most of these sources exhibit a certain degree of human or artistic interpretation. But, when all of the sources are incorporated into a comparative analysis, wherein reliefs are compared to models, drawings to literary references, etc., a very accurate statement--a definition--can be formulated about the construction features of a sewn boat.

Because of the scant number of references that either refer to or show construction details of sewn boats, it was difficult to choose one particular vessel type to study in detail and analyze. The success of comparative analysis depends on the quality and quantity of the references.

The antiquity and widespread use of sewn vessels within our research parameters suggest numerous possibilities for research. Most depictions or references, however, are limited to isolated or singular examples, and it should also be noted that no sewn boats capable of open-ocean sailing remain now in the Western Indian Ocean. Their demise occurred in the relatively short period of time which started with the entrance of the Portuguese into the Western Indian Ocean in the late 15th century and ended with the complete extinction of sewn boats in the early years of the 20th Century (Martin, 1978:76). Because of this late date of extinction and the vessel's anomalous existence as a relic, there are relatively large numbers of references to its construction. The most unique and accurate are the photographs.

The vessel regarded as the last of the large sewn vessels, the mtepe was constructed primarily in the Lamu Archipelago off the coast of Kenya (Chittick, 1980:297-298) (Fig. 3). Because of an abundance of information on the type, it was

chosen for study as the vessel representative of sewn boats of the Western Indian Ocean of antiquity.

The mtepe, which is of undefined antiquity, was only slightly modified during its last twenty years of existence. Changes were primarily cosmetic. The most clearly identifiable difference between the mtepe and its later, modified form, the dau la mtepe, was the reduction in the amount of decoration and the replacement of the highly decorated beak-like prow with a simple bowsprit.

Sources pertaining to the mtepe allow a definition of its individual components and an understanding of the method in which they were combined. An overall view of the vessel emerges that indicates use of a very different construction design from that of vessels built in the "western boat building tradition". Although the references allow an accurate description of the sewn boat, a quantifiable analysis of the boat is not possible due to the lack of accurate dimensions. So a closer look at the vessel with a qualitative interpretation is necessary.

As a result of Swahili being historically a non-written language, various spellings of mtepe have entered the literature. To complicate matters further, the descendant of the mtepe proper, the dau la mtepe, has also been referred to with several different spellings. To clarify and simplify the reading of this thesis, the terms for the two distinct forms of the mtepe will be spelled in accordance with those used by Prins (1959:205-208). The original spellings by various authors have been included in Appendix 1 (p. 99).

The thesis has been organized in a progression that parallels the construction of the sewn boat. The definition of each component is integrated with an analysis of its function as part of the sewn boat. There is one exception to this pattern; the Hull Construction and the Hull Analysis have been separated because the function of the hull can be more easily comprehended after a complete picture of the hull has been formed in the reader's mind.

SOURCE REVIEW

Sources of information include literary references, archaeological examples, depictions (which include photographs, reliefs, models, and drawings) and remaining relatives. The sources are reviewed in chronological order to enable the reader to better understand the quality and amount of information available in each time period to aid in defining the construction features of the "sewn" boat.

The first references to seafaring within the Western Indian Ocean survive from the earliest civilizations of the Fertile Crescent. These depictions are primarily of papyrus craft, with very little detail shown, which were not designed for extended voyages (Bass, 1972:13-33, with figs. 1-5, 7-12, 14-22 and pls. 2-6, 8-24, 27).

Among the earliest recordings of vessels in the area are the rock drawings of the 4th millennium B.C. in the Wadi-Hammamat, an ephemeral stream between the Egyptian Red Sea coast and the Nile Valley. These drawings are simple and vague, and it cannot safely be said whether they represent sewn boats or even boats capable of open-ocean seafaring (Winkler, 1939). The same can be said of the crude representations that are found on pottery of the Gerzean period (Bass, 1972:13, 26).

Later records from Egypt show that dynastic watercraft were almost exclusively designed for riverine use (Faulkner, 1941:4), of a design which is inapplicable to ocean-going vessels. Several actual examples have been preserved that lend insight into the concept of their construction, showing construction features that have similarities to those of later sewn boats.

The earliest archaeological example of a sewn vessel is the Cheops funerary boat of the Egyptian Old Kingdom, ca. 2650 B.C. (Abubaker and Moustafa, 1971.) Although numerous boat models associated with Egyptian burials have been discovered, the Cheops boat is the first example that provides an opportunity to examine actual construction methods, particularly the methods of fastening. This archaeological example also gives us the opportunity to examine the proportions and dimensions of boat construction of the period. Although classified as papyriform and constructed for riverine use, it is of particular note in this review as it utilizes lashing for fastening and is plank built in a carvel manner.

The next archaeological examples are the boats associated with the burial of Pharaoh Sesostris III (ca. 2080-1786 B.C.) from the Egyptian Middle Kingdom, referred to as the Dahshur boats (Reisner, 1913: 83-87). Several were unearthed in various states of preservation, with the best preserved of these on display at the Chicago Field Museum, with one in Pittsburgh, and the others remaining in Egypt. The boat in the Chicago Field Museum appeared, upon personal observation, to be nearly a floating raft with timbers almost 4 inches in thickness. Certain features of its construction are noteworthy: the tenons were aligned with the individual strakes, inset dovetails were used to prevent separation of the planks, and thwarts protruded through the hull.

Examples of papyriform vessels associated with riverine activities are found in the form of models included as grave goods in the burials of nobility throughout the dynastic period ((Reisner, 1913:83-87; Winlock, 1955: pls. 33-37, 40-43, 45-48, 51, 52, 70-76, 78-86; Glanville, 1972: pls. 272-280). Details of propulsion, steering, and rigging can be gleaned from these models, but because the hulls are carved out of single blocks of wood little detail concerning fastening or internal components is shown.

The earliest vessels clearly capable of open ocean voyaging are preserved in the depiction at Deir-el-Bahari of Queen Hatshepsut's great expedition to the Land of Punt (ca. 1500 B.C.) (Landstrom, 1961:33-34). These vessels have the papyriform hull form of riverine craft, but appear to have been structurally strengthened for ocean voyages with three particularly important features: the hogging truss, through beams, and stitching visible on the hull. Another depiction on the temple at Deir-el-Bahari displays a great achievement in naval architecture, one of the largest vessels constructed in the ancient world, the Obelisk Barge of Queen Hatshepsut (Landstrom, 1961:35-36). This vessel, capable of carrying obelisks weighing an estimated 350 tons, is characterized by its multiple tiers of through beams and the use of multiple hogging trusses and lashings to provide its structural integrity. This vessel was designed for riverine use as a lighter and bears little resemblance to oceangoing vessels.

From the time of the Egyptian decline into relative mediocrity after 1100 B.C. (Bass, 1972:21), depictions of sewn vessels become infrequent. Persian and Sabaeen activity continued in the area, but with no specific references to details of the construction of their vessels. The African coast remained uncivilized (Chittick, 1970:129-133), and scant references to activities along the Indian coast

(Mookerji, 1962) have limited value. The next source in the sparsely preserved record comes from the voyages of a Greek merchant of the first century A.D. who recorded the sailing directions to the ports of the Red Sea and the East African littoral in a book called Periplus of the Erythraean Sea (Huntingford, 1980). He encountered sewn vessels near his southern terminus of trade in southern Tanzania. He describes them as "-small boats sewn and made from one piece of wood, which are used for fishing and catching marine tortoises." (Huntingford, 1980:29)

This brief statement gives us a very unclear image of the nature of construction of these sewn boats. The observations made by this Greek merchant are remarkably similar to the comments of later European explorers of the past few centuries in both vagueness and brevity, but the reference is significant as it clearly records and documents the antiquity of the sewn boat.

From the centuries following the writing of the Periplus of the Erythraean Sea little is known about the construction and evolution of sewn boats as limited archaeological evidence has been recovered in the Arabian, African, and Indian coastal areas. In the 10th and 12th centuries A.D., evidence of the construction of sewn vessels in the Red Sea comes from Arabic sources (Fahmy, 1966b:80) The first clear representation of value in understanding the construction of sewn vessels is the depiction of an Arab vessel from the 39th Maqamat of al-Harriri (ca. 1225-1235) (Ettinghausen, 1977:108). This miniature painting shows vertical stitching between the strakes, a defined stem, keel, and sternpost, and the first western Indian Ocean depiction of a stern rudder. This boat is often regarded as the predecessor of the modern-day Persian Gulf booms and is also similar in construction to the mtepe. In the 13th century, the famous explorer Marco Polo described a boat from Hormuz in the Persian Gulf in less than glowing terms: "Their ships are wretched affairs, and many of them get lost; for they have no iron fastenings, and are only stitched together with twine made from the husk of the Indian nut. It keeps well, and is not corroded by sea water, but will not stand well in a storm. They have one mast, one sail, one rudder, and have no deck . . . Hence 'tis a perilous business to go a voyage in one of these ships and many of them are lost, . . ." (Yules, 1875:111).

From the 13th century to the 19th century very few references to boats of sewn construction have been preserved. The earliest foreign presence in East Africa is indicated by the occurrence of 9th and 10th century A.D. pottery originating from the Persian Gulf area (Were, 1968). The archaeological record is

particularly sparse with a major portion of the archaeological record coming from the excavations of coastal cities of Kenya (Kirkman, 1970:247, 252-253). Among the earliest visitors to the Western Indian Ocean were Ibn Battuta (Gibb, 1958) (1325-1354), Friar Oderick (Hornell, 1970:235) (1331) (whose journeys were translated by the Hakluyt society), and El-Makrisi (Hornell, 1970:235) (ca. 1400-1450). From the first voyage of Vasco de Gama in 1497 we learn of the vessels of Mozambique: "The vessels of this country are of good size and decked. There are no nails, and the planks are held together by cords as are also those of their boats ('barcos'). The sails are made of palm matting. Their mariners have Genoese needles, by which they steer, quadrants, and navigating charts" (Gama, 1898:26). The narratives of Duarte Barbosa in 1521 describe a sewn vessel of the Pemba, Mafia, and Zanzibar Islands that is undoubtedly a relative of the mtepe. He also writes: "In these isles of Maldiva (Maldive Islands) they construct many large ships of palm trees, sewn together with matting, for there is no other wood there. Some of these sail to the mainland, and are ships with keels and of much tonnage." (Barbosa:164) This quote is particularly significant for the type of wood used and the distances which these vessels travel. The list of visitors to the western Indian Ocean continues with the visit of Caesar Frederick in 1583, (Hornell, 1970:235) John Eldred in 1583, (Hornell, 1970:235) and J. Lancaster (Hornell, 1970:235) circa 1595. A few details of construction of sewn boats were noted by James Bruce, (Bowen, 1949:109) who sailed in a sewn vessel in the Red Sea in 1813. The writings of Richard F. Burton, the famous Arabian and African explorer (1821-1890), lend little detail concerning sewn boats (Burton, 1893). With the beginning of European exploration and exploitation in the late 19th and early 20th centuries, numerous references were made to the last of the sewn boats of the coast. It was these numerous references to a single boat type that focused my research and allowed for an accurate definition of its construction. The vessel in question was the highly decorated mtepe that was constructed primarily in the islands of the equatorial East African littoral. These vessels were engaged in all forms of trade and ranged from Lindi in the south to Aden in the north (Owen, 1833). During a voyage of exploration undertaken by Captain W. F. W. Owen to the shores of Africa, Arabia and Madagascar he gives in some detail the description of what is probably a mtepe or a close relative from the island of Patta (Pate in the Lamu archipelago) (Owen, 1833:391).

The description of the voyage made by Guilan in 1846 is once again brief. The drawings of small boats of the East African littoral, including the mtepe, have lent little detail to the construction of sewn boats. Of particular interest and value are the clear depictions of the rudders of these vessels and the manner in which they are beached (Guillain, 1848: pls. 51-52).

Illustrated publications concerning the mtepe begin with Stuhlman, Handwerk und Industrie in Ostafrika (1910). His description is limited and his historical summary brief, but he suggests that the mtepe is a relative of the boats of the Periplus of the Eyrthraean Sea. His book includes a photograph of a dau la mtepe which is labeled as "Mtepe-Fahrzeug aus Lamu" (Fig. 4) (Stuhlmann, 1910:83, fig. 46).

The first detailed description of the large seagoing sewn boat, the dau la mtepe, complete with several drawings, was made by Lydeker (1919). His 4-page description with drawings includes numerous Swahili terms for various portions of the vessel, but several mistakes are present in the drawings. Lydeker's Fig. 1 was corrected by Hornell, who was "compelled to conclude that this figure appears to have been drawn by one who was without technical knowledge of the subject and that the whole arrangement of the rigging is inaccurate" (Hornell, 1941:63). Inaccuracies included that the mtepe proper used the built-up stem that was characterized in the later dau la mtepe, that the yard was improperly placed, and that there were inaccuracies in the rigging. In addition the quality of the drawing (Lydeker's Fig. 2) helped lead Hornell to the inaccurate interpretation of the method of fastening one plank to another. Finally, the reproduction of the photograph (Lydeker's Fig. 6) is so poor and the boat at such a distance that this photograph was not included in my plates. Although this is one of the few publications describing the mtepe its numerous errors make one carefully examine all reported details.

The next of the articles identifying the mtepe (Pearce, 1920) as the boat of the Periplus of the Erythraean Sea deals more with the possibility that the ancient city of Rhapta, the city at the southern terminus of the Periplus, is buried beneath the alluvial soil of the rivers across from Zanzibar. Pearce further surmises that this city must surely have been fortified "to keep out wild beasts and anthropagi" (Pearce, 1920:32). The article also contains a short reference to the significance of the coloration and flags of the mtepe based on local legend. The most enlightening statement made by Pearce, who considered it to be an "odd belief,"



Figure 4. "Dau la mtepe from Lamu", Fig. 46, p. 83 in Stuhlmann, Handwerk und Industrie im OstAfrika, 1910.

was that the mtepe was not able to carry a cargo of coconuts. He explains this by saying that "Some deep-founded superstition is probably at the bottom of this particular aversion to carry coconuts in this style of craft" (Pearce, 1920:30). We shall see later than this "odd belief" is based on a comprehension of physics.

Field, The Country Gentlemen's Newspaper from September 24, 1925, dedicates nearly two pages to the description of the dau la mtepe. Again, errors were made in the drawing of the rigging of the dau la mtepe, and the method of fastening the planks to one another was left mostly to the interpretation of the reader. The article is detailed in its descriptions and covers a wide range of the mtepe's activity and history, but many of the statements made in the article have to be carefully scrutinized as the author seems to have had some peculiar interpretations. Among these ideas are his interpretation of the purpose of the decoration or flags that the boats carried. The anonymous author states that "My own belief is that the masthead pendant serves to raise the ship above the top of the mangroves to flutter defiance to any evil spirit which may be lurking in the air, while the flags on the bowsprit are a challenge to any which may be lurking round a bend, the fringe of charms being the defensive armaments" (Field, 1925:524). The greatest contributions of this article are the dimensions that are given for a few of the components, and a crude lines drawing of a dau la mtepe.

In 1931 a book entitled Zanzibar: Its History and Its People (Ingram, 1931) devoted several pages to the identification of various watercraft that visit the islands of the East African littoral. In them the author disagreed with the favored theory for the legendary origin of the mtepe. The author also offers an explanation for the existence and longevity of the practice of sewing boats, stating that the "real raison d'etre" of the mtepe was "probably the lack of . . . nails at this early period of history" (Ingram, 1931:305).

These few references from the early 20th century are the only first hand observations of the mtepe and its later descendant, the dau la mtepe. The last of the dau la mtepes was said to have been constructed in the 1930s; (Martin, 1978:94) with a reported life span of only three or four years (Lydekker, 1919:91), they soon became totally extinct. The next and foremost study of the mtepe was published in 1941 by the prolific James Hornell. His work was primarily based on the previous descriptions by Lydekker, Field, and by A. C. M. Mullins (the district commissioner of Lamu, Kenya, in the 1930s) and his wife .

Hornell's technical descriptions and definition were based primarily on the study of one of the replica models of the mtepe which is located at the Science Museum, South Kensington, England (Figs. 5-6). Hornell covers a wide range of the mtepe's activities, defines portions of the boat's construction, and corrects several mistakes or errors that had previously entered the literature. Although his publication has been the standard for further publications certain misinterpretations were made by Hornell. Among the inaccuracies are the distance that the through beams projected from the hull (corrected by Chittick, 1978:2) and the primary method by which the hull strakes are joined to each other.

In the 1955 publication Pescatori dell'Oceano Indiano, Grottanelli includes details on the production of palm matting and line, as well as a 1937 drawing which is inaccurate and with little detail (Fig. 7). His description of the mtepe and its uses are repetitive and lend little new detail to the definition of the construction of the mtepe.

A. H. J. Prins in 1959 published in Tanganyika Notes and Records a brief review of previous literature relating to the possible cultural origin of the mtepe. In addition he refers to the existence of several models, one in Zanzibar Museum which he regards as "atypical" (Prins, 1959:210), two in Lamu, one in Mombasa, and the model in the South Kensington Museum that was the subject of Hornell's publication (1941). In his subsequent publications Prins mentions the presence of a graffito on the wall of a house at the ruins at Gedi near Malindi. This graffito "depicts the peculiar hull of what is unmistakably a mtepe" which he "provisionally dated as a 15th or 16th century work" (Prins, 1959:211).

In addition Prins reports the discovery of a portion of sewn hull planking used in the construction of the ceiling of the guard room at Fort Jesus in Mombasa (Prins, 1959:211). This discovery was later credited by James Kirkman (1974:16) to "Hornell 1941, Grottanelli 1955 and Prins 1959". Neither Hornell or Grottanelli mention this planking in either of their publications so credit for drawing attention to the ceiling should be attributed solely to Prins. Although during my stay in Mombasa I examined the ceiling of the guard room in question, I found no evidence (i.e., marine fouling, teredo holes, etc.) that would indicate previous marine use. In addition, two references from the first voyage of Vasco de Gama in 1497 lead us to question the statement made by Prins. During Vasco de Gama's stop in Melinde (current-day Malindi, located north of Mombasa), "It is said that here he was shown how to replace his water casks by fitting below decks large tanks formed of planks

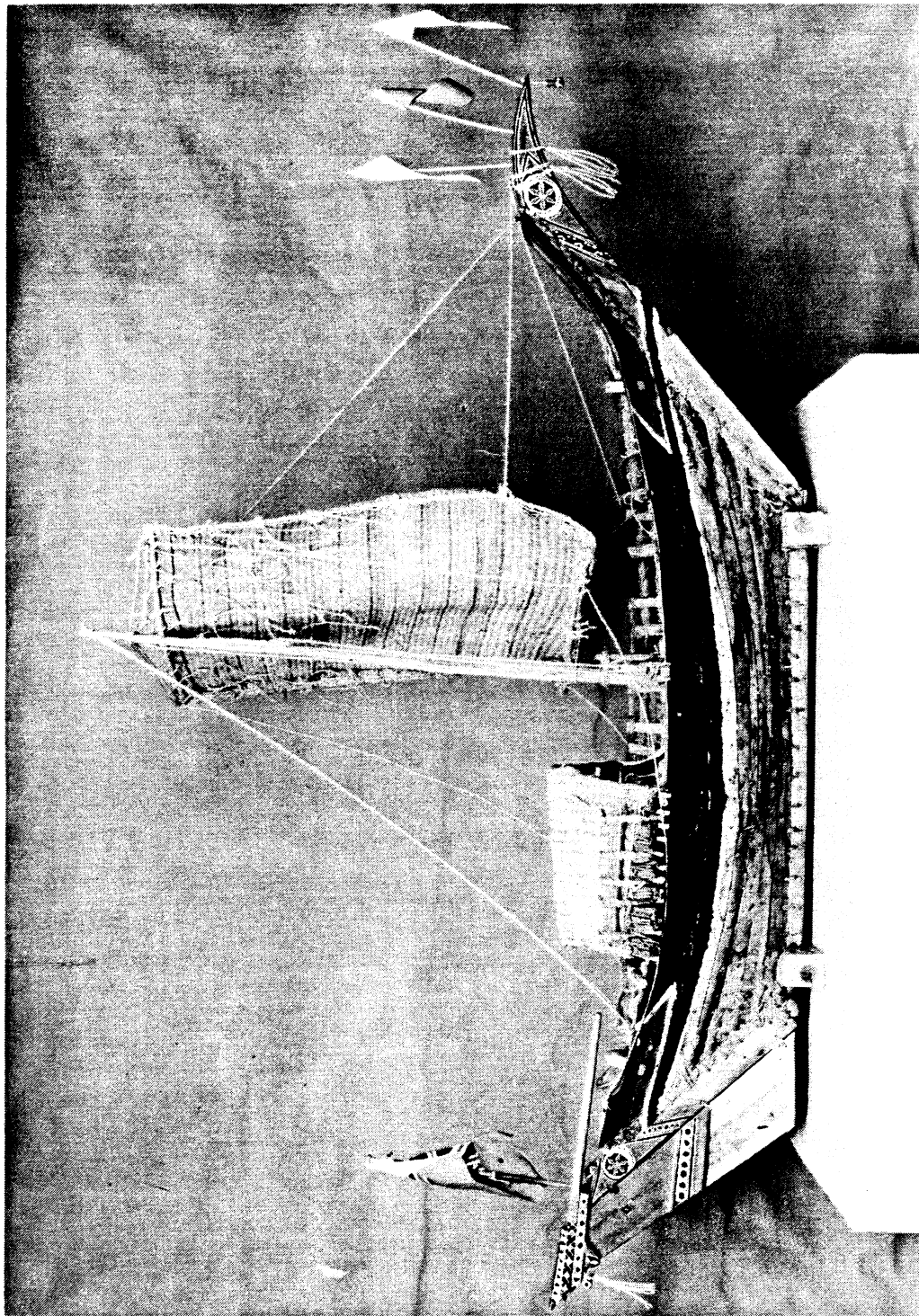

Figure 5. "Mtepe from Lamu. Rigged Model 1936-19". Broadside 8349.
Science Museum, South Kensington, England.

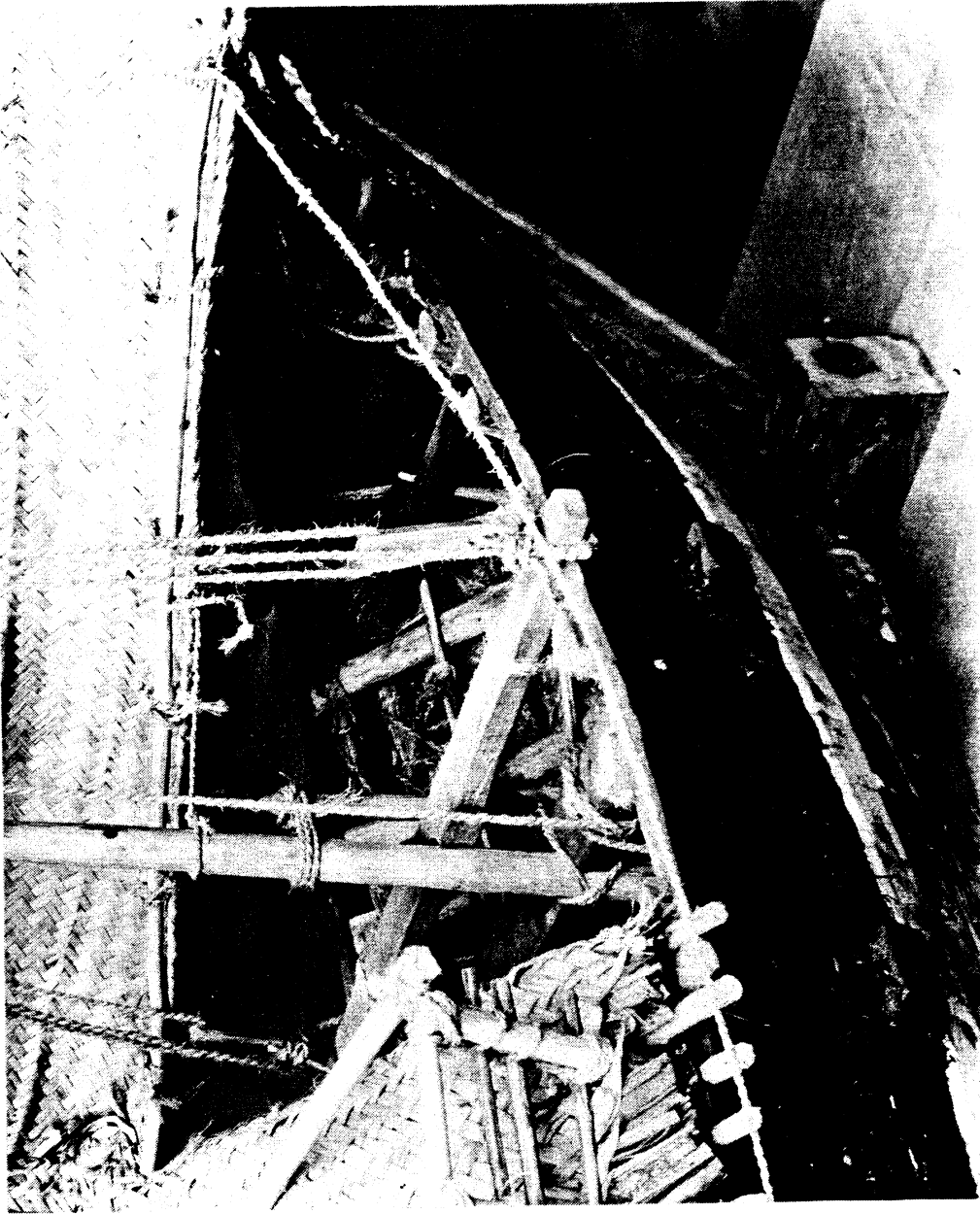
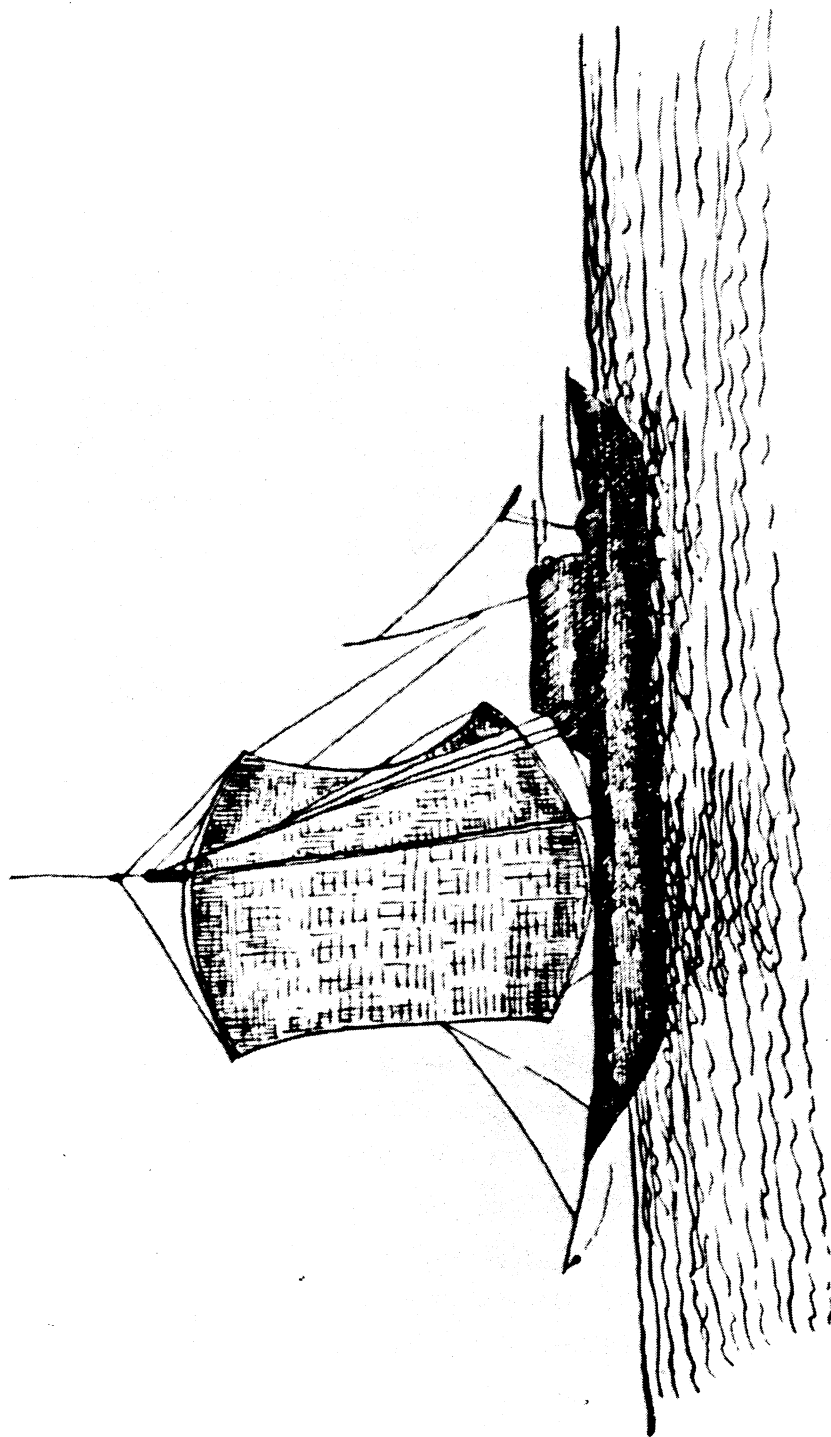

Figure 6. "Detail of Mtepe from Lamu. Rigged Model 1936-19". Port Quarter 8350. Science Museum, South Kensington, England.



"Drawing of dau la mtepe", Fig. 102. (da G. Corni, Somalia Italiana, 1937) - from Grotanelli, Pescatori Dell'Oceano Indiano, Rome, 1955.

Figure 7.

sewn together and caulked with pitch, four tanks for each ship" (Jones, 1978:71). And in reference to the unfriendly encounter with the Moors off the Malabar coast, "The Moors had constructed palisades by lashing planks together, so that those behind them could not be seen. They were at the time walking along the beach, armed with assegais, swords, bows, and slings with which they hurled stones at us" (Gama, 1898:30). It is my opinion that the ceiling was not constructed from the hull planking of a mtepe. The technology of fastening one plank to another was well known and had many applications. Among those applications was the construction of the ceiling of the guard room at Fort Jesus.

In 1965 Prins published Sailing from Lamu which details various watercraft of the Lamu Archipelago with an in-depth discussion of their decorations. His analysis of the construction of the mtepe is based on the study of the Science Museum Model, the same model that Hornell used for his publication of 1941, and the two models in Lamu. Prins was aware of only one photograph which showed a mtepe.

The next reference to the mtepe is in the outstanding publication of E. B. Martin (1978). In his book which details both local and foreign trade of the East African Littoral and western Indian Ocean he also has published in its entirety a report of district commissioner of Lamu, J. Clive (1933), which briefly described the construction of a dau la mtepe and the operation of the boat. In addition Martin has published two photographs: one of the mtepe proper with two other mtepes in the background, and one of the dau la mtepe. This photograph of the mtepe, I believe, is the photograph whose existence Prins mentioned in his 1965 publication.

Jewell (1969) included several pages on the mtepe and dau la mtepe. His book, which is mainly pictorial includes photographs of two dau la mtepes, one viewed from the stern and the other viewed in profile, taken at quite a distance and showing very little detail. Also included are photographs of two models that are in the Fort Jesus collection in Mombasa. Upon careful examination of the photograph of the mtepe model it can be seen that the photograph has been retouched (Fig. 8). The rudder on this model does not fit and the photograph has been retouched for aesthetic reasons. Also the fringe, or the "beard", that is usually under the beak-like prow of the boat is missing from the model. This "beard" was discovered by the author tucked under the foredeck of the model. The other photograph is a model of a dau la mtepe (Fig. 9) showing several curious

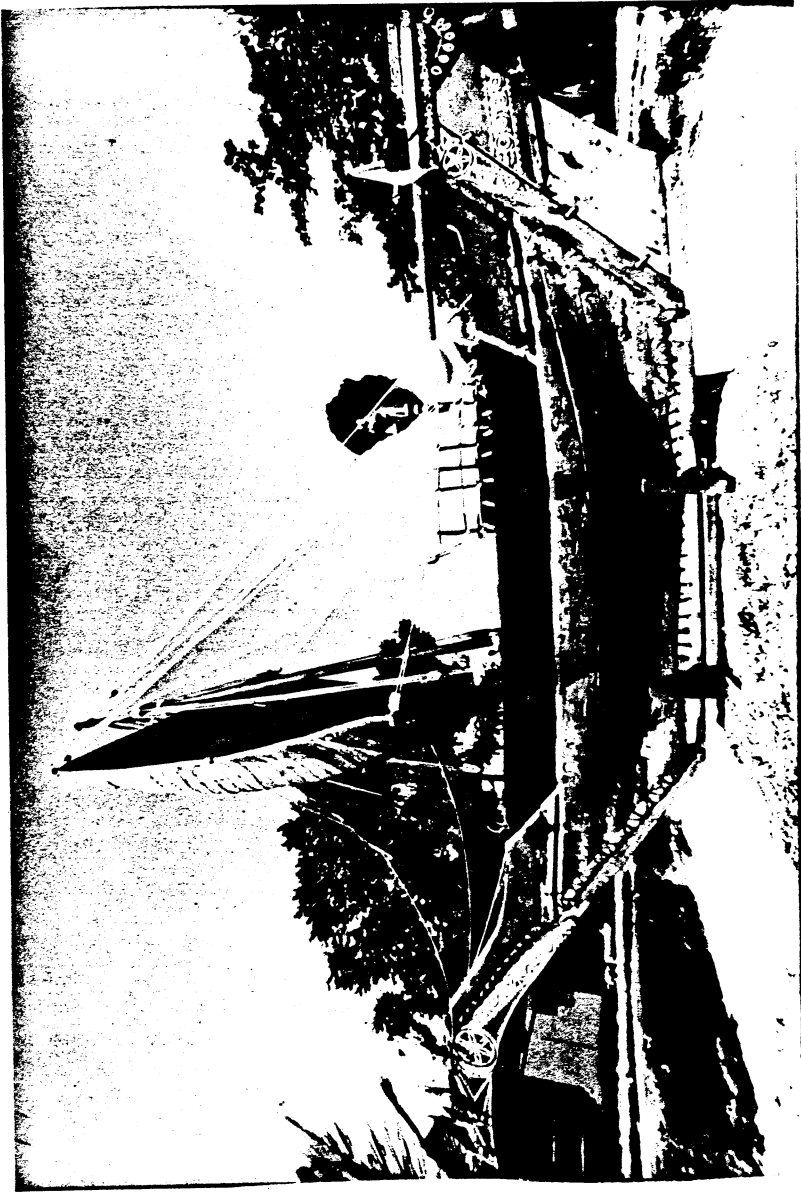

Figure 8. "Dhow-Mtepe - presented by Commander W. G. Murphy-King" - Fort Jesus Museum, Mombasa, Kenya.



Figure 9. "Dau la mtepe model - Fort Jesus Museum, Mombasa, Kenya."

features. The hull was carved and not plank built as was the case with most of the other models. In addition, iron nails were used to secure the oculus and the carved ornamental board to the side of the hull, and to secure the bowsprit to the forwardmost thwart. It is interesting that these features which are fastened with nails are considered modernizations that clearly distinguish the dau la mtepe from the mtepe proper.

Neville Chittick, Director of the British Institute in East Africa, in recent years has published twice on the subject of the mtepe: a paper delivered at the International Conference of Indian Ocean Studies in Perth, Australia, in 1978, and his subsequent publication in IJNA (9, 1980). These papers detail the survival of a small sewn boat built on the coast of Somalia with which several parallels are drawn to the mtepe's construction. The sewn boats of Somalia are without question closely related in form and in construction techniques to the mtepe. Numerous photographs in the IJNA article are very valuable in the comparative analysis between the two boats.

Chittick reports the presence of only one photograph of a mtepe which has been previously published (Martin, 1978:95). He calls attention to 3 photographs of the dau la mtepe and to the drawings or sketches in Grottanelli (1955) and Lydekker (1919). His list of models includes more than one model in the Lamu Museum, the models at Fort Jesus, and the model studied by Hornell and Prins in the Science Museum, South Kensington, England.

The preceding source review shows that relatively little information exists regarding the specifics of the construction of ocean-going sewn boats in the western Indian Ocean. The most plentiful sources are those 20th-century references to the construction of the mtepe, the last of the seagoing sewn vessels of any appreciable size. We have seen that the majority of this information is derived from secondary sources and that several errors or misinterpretations have occurred regarding the construction of these vessels.

When I began my research I had the opportunity to start with the dau la mtepe model (Fig. 9, p. 22) and two mtepe models that are of very good quality at Fort Jesus, Mombasa, Kenya (Figs. 8, p. 21 and 10). In addition to these models the museum's limited files of photographs revealed eight photographs, six of the dau la mtepe which have not previously entered the literature, and two of the mtepe proper; one of the latter was published by Martin in Cargoes of the East (1978) and the other was unpublished (Fig. 11). In addition to this relative wealth of



Figure 10. "Bajun Mtepe - made for Sir Mbarak bin ali Hinawi" - Fort Jesus Museum, Mombasa, Kenya.



Figure 11. "A mtepe", Fort Jesus Museum, Mombasa, Kenya.

information, Mr. Hamo Sassoon drew my attention to a photograph of a mtepe at Tanga, Tanzania, taken in 1895, which has not previously entered the literature (Fig. 12) (Hollis Papers, vol. 294, Rhodes House, Oxford). With this abundance of information in hand the comparative analysis between features of the models and those shown in the photographs became possible. Afterwards I visited the Lamu Museum where two models were supposed to be located. Upon my arrival I found only one model present in the Museum (Fig. 13), a model of somewhat less accuracy than the models in the Fort Jesus collection. I have later learned through personal communication with Mr. David Sentance that another model is present on the island at Petley's Inn. A request for a photograph of the model to the owners of Petley's Inn has not brought a response. The model that was reported by Prins and considered "atypical" in Zanzibar was at the time of my visit inaccessible due to political unrest and closed borders between Kenya and its neighbor to the south, Tanzania. Another model was reportedly being delivered to the National Museums of Kenya in Nairobi. Its origin, quality and antiquity is still in question (personal communication Dr. Ann Spoerry, 1982).

The only other known models of the mtepe are the Science Museum model in South Kensington (Figs. 5-6) and two models at the National Maritime Museum, Greenwich, England, one of a dau la mtepe without rigging (Fig. 14) and one of a mtepe from Lamu (Fig. 15).

It is this relative plethora of information on a single boat type and hull form that has allowed the definition of the mtepe. This definition was accomplished by a comparative analysis between the literary references, models, and photographs.

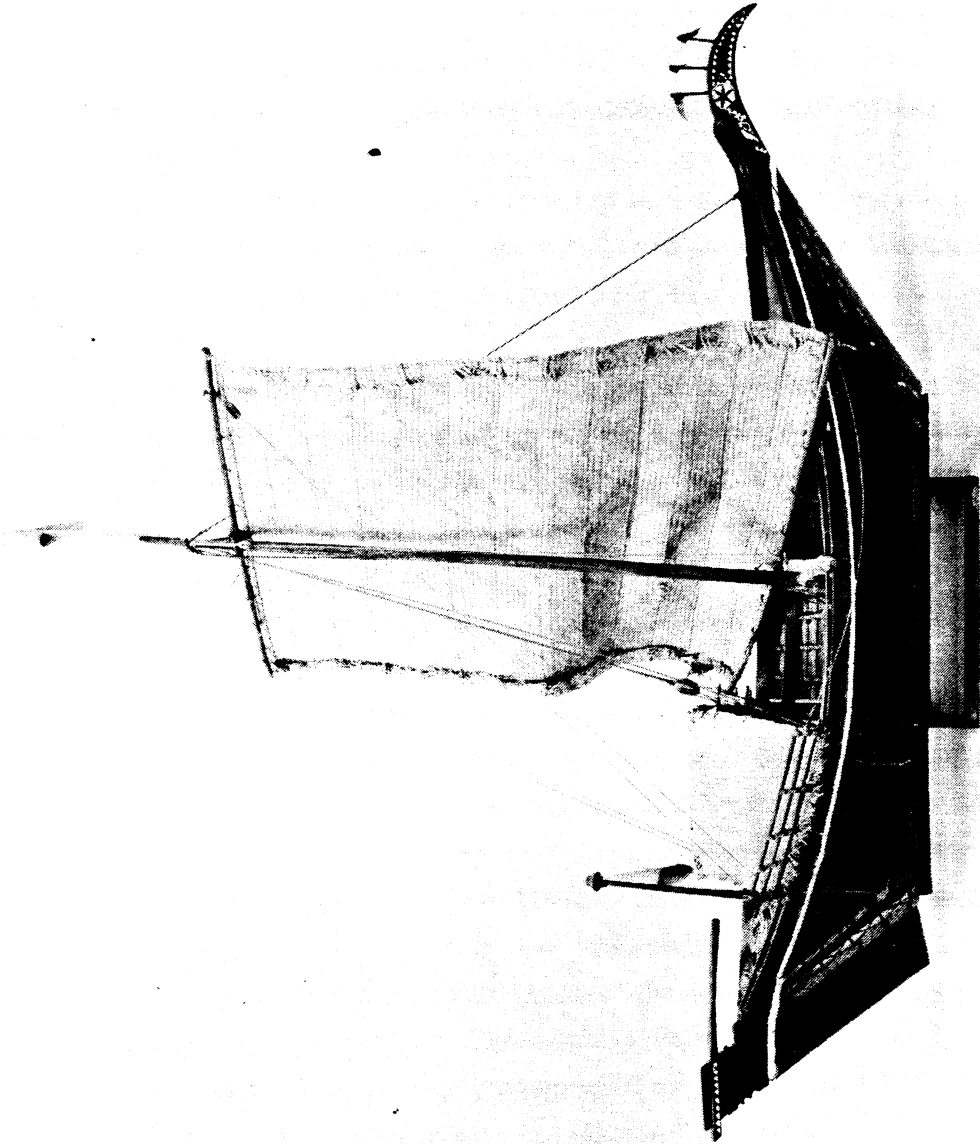

Figure 13. "Mtepe - donated by Dr. Ann Spoerry" - Lamu Museum, Lamu, Kenya.



Figure 14. "Dau la mtepe - unrigged - B5081", National Maritime Museum, Greenwich, England.

Figure 15. "Mtepe, B5082; National Maritime Museum, Greenwich, England.



HULL CONSTRUCTION

Due to its relatively recent extinction, the mtepe of the East African littoral is the only sewn boat for which numerous sources have been preserved. From these sources definition of the components comprising the hull can be made.

Construction began with laying the keel, a single timber without scarfs. The cross sectional profile of the keel indicates it may have been radially split or sawn from the original timber.

The hull of the mtepe was constructed in a shell-first, carvel manner. The planking was hewn from freshly harvested mangrove trees (Hornell, 1941:59). Individual planks were reported to have been 1½ feet wide or somewhat more (Prins, 1965:210).

The garboard strake was attached to the keel by sewing and by the use of dowel tenons. There is no record of whether the garboard was set into a rabbet in the keel. Photographs are of no value in this case and it was not possible to make a determination from the models. However, vessels constructed in the Arab tradition throughout the Western Indian Ocean were built without a rabbet along the keel (Horwath, 1977:63). Instead, the garboard strake was doweled to the top of the keel. It is probable that the mtepe was constructed in this manner.

The method that was used to fasten the garboard to the keel and the strakes to each other has been difficult to define. Hornell incorrectly stated that the method of fastening the mtepe, other than by sewing, was with the use of oblique wooden nails (Hornell, 1941:65). His deduction was based on his observations of the Science Museum model (Figs. 5-6, pp. 17-18) and the vague description of an earlier first-hand observer of the dau la mtepe. (Hornell was the first to publish on the subject from secondary information after the demise of the mtepe and its descendant the dau la mtepe.) These early references to the dau la mtepe's construction were brief and often accompanied by inaccurate drawings. It was one of these drawings that led Hornell to his inaccurate conclusion concerning how the hulls of these vessels were fastened. The model on which Hornell based his writings seems to show oblique nailing. The dowels manifest themselves on the exterior of the model, misleadingly, as ovoid in cross-section, although in an actual boat rarely do these ovoid cross-sectional profiles of the dowels appear. Two explanations can be offered. One is that the dowels were infrequently used as

nails. The second is that the ovoid profiles are the result of adzing of the hull. The actual method in which these planks were fastened to each other was with dowel tenons set vertically between the planks. The dowel tenons were not visible on a completed vessel. Evidence of this can be seen in Fig. 16, where two planks on the stern quarter have separated and a dowel tenon is visible. In addition, a remaining relative of the mtepe on the coast of Somalia has these vertical dowel tenons joining its strakes (Chittick, 1978:4). The abundance of dowels with ovoid cross sectional profiles present on the Science Museum model (Figs. 5 and 6) may be attributed to the modeler's difficulty in working at a reduced scale (Fig. 17).

Secondary fastening of the planks was accomplished by sewing. It was this sewing of the hull which, when observed by early historians, led to the general classification of these vessels as "sewn boats". The inability of the early observers to see the vessel under construction may have led to the misconception that the vessels relied completely on stitching for their structural competence. This misconception may have contributed to the misgivings of Marco Polo, a feeling that was evident in his description of a sewn vessel in which he was a passenger in the 13th century (Yules, 1875:111).

The cordage used to sew one strake to another and the keel to the garboard was manufactured from the husks of coconuts (Lydekker, 1919:88). There are many spelling variations for this cordage; it will be referred to here as "coir". This cordage was used not only for stitching the hull, but also, in various sizes, for lashings and rigging. Coir fiber line was used throughout the Western Indian Ocean and was one of the major trade items of the Maldiv Islands in the 16th century (Gama:1). Use of coir cordage has continued for centuries and has only recently begun to be replaced by factory-manufactured line in the smaller sewn boats of the Somali coast (Chittick, 1978:4).

After the strake had been set in position over the dowel tenons the seams between the strakes were caulked. A thick paste of pounded mangrove bark was used. Each seam was then covered with a strip of crushed coconut husks, and then a layer of dried dom palm fiber (Hornell, 1941:61). The caulking procedures used on the mtepe are the same as those used on the smaller sewn boats of the Somali Coast at Ras Hafun. The only difference is that the pounded mangrove bark has there been replaced by commercially available pitch (Chittick, 1978:4)(Fig. 18).

The fiber covering on the interior strake seam of the boats at Ras Hafun appears to be very similar, although the fiber's origin in these boats is unknown

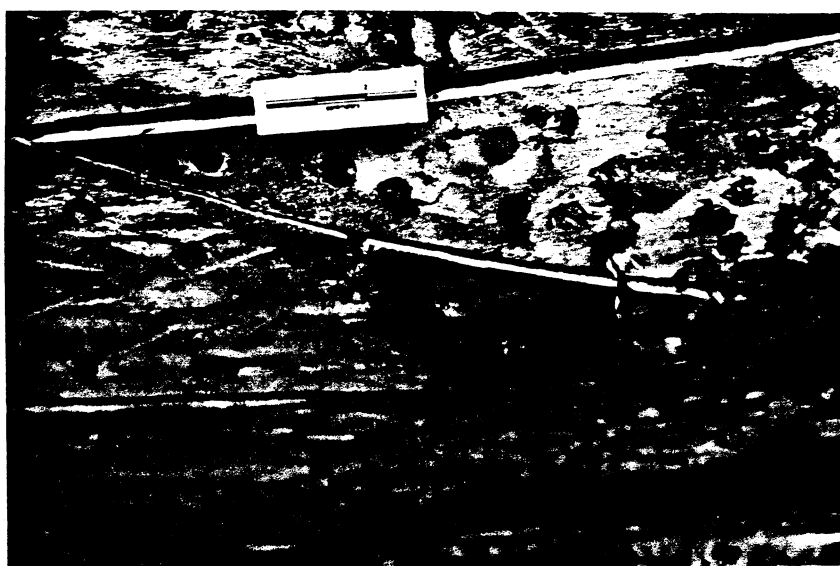

Figure 16. Separated planks showing dowel tenon.

**"Bajun Mtepe - made for Sir Mbarak bin ali Hinawi", Fort Jesus Museum,
Mombasa, Kenya.**

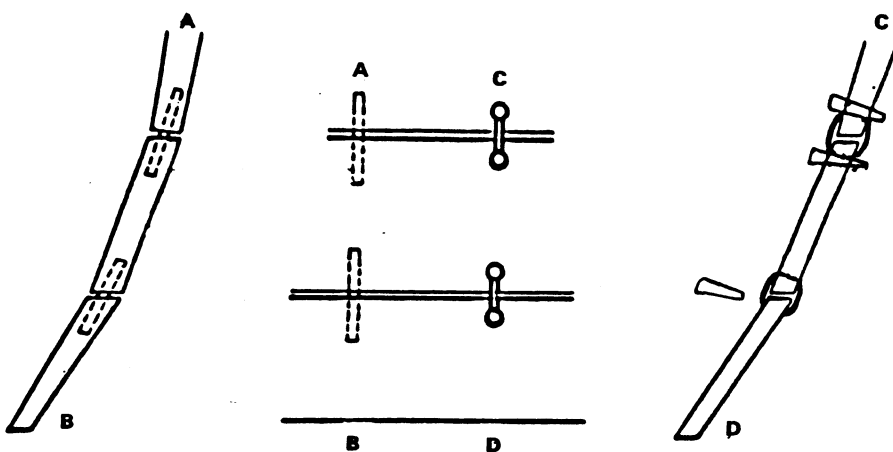
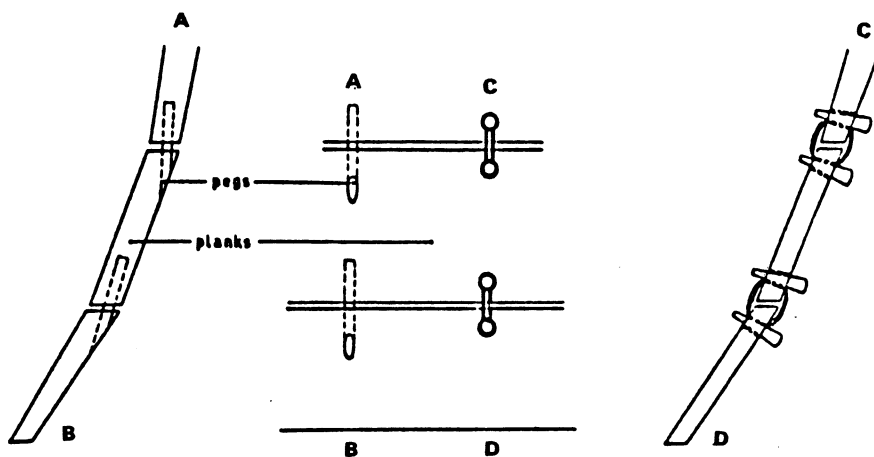

Figure 17. Correction of dowel tenon and pegging procedure from Prins (1965 :120).



Figure 18. Pouring pitch into planking seam as part of caulking procedure.

N. H. Chittick, "Sewn boats in western Indian Ocean and a survival in Somalia", IJNA 9 (1980) 301.

(Chittick, 1978:4). The cordage used to sew the hull of the mtepe was a simple coir twine that had a palm leaf splint woven into the end of the line as a needle (Hornell, 1941:61). The sewing of the hull was completed in approximately six-foot sections. (The length of a section of stitching in the initial construction of the boat is assumed to be the same as that which was done at one time during the annual overhaul and complete resewing of the hull.) The sewing was done by two men; one inside the hull, the other on the outside (Hornell, 1941:61). The man on the inside threaded the palm leaf needle through a hole in the strake that had been bored with a bow drill and then drove a peg into the hole to wedge the cordage. The man on the outside of the hull passed the needle back through the next hole. The inside man threaded the palm leaf needle back through the strake to the man on the outside of the hull who took several turns of the line around a stick to aid in pulling the cordage taut. Then the man on the inside drove a peg in the hole only deep enough to maintain tension on the line while the cordage was passed back through the next hole. The man on the inside of the hull took the line and passed it back through the next hole. The outside man once again pulled the line taut and the inside man removed the peg that was holding the tension on the line and moved it to the next hole and drove it in to maintain tension. This procedure was repeated for approximately a six-foot section of the hull and was then reversed over the same section of the hull (Fig. 19). After the section of stitching was completed pegs were driven into each hole from the inside of the hull outward. The protruding portion of the peg and the exterior stitching was adzed off (Hornell, 1941:61).

After several (probably two or three) strakes had been built up from the keel, the stem and sternposts were added to the hull (Chittick, 1980:301).

Construction details of the stem and sternposts of the mtepe have been a topic of discussion since early in this century. The distinction between the mtepe and the dau la mtepe was primarily based on this feature. The later dau la mtepe utilized a unique system of forked blocks built up one atop the other (Hornell, 1941:55). It appears that the built-up stem is unique to the dau la mtepe, although its use in the dau la mtepe is not exclusive of the older, conventional one piece style stem post. This later stempost design is believed to be the result of economic changes and was present primarily in the smaller dau la mtepe. The focus of this thesis is not to define this later modification but to define the stem and sternpost of the mtepe proper.

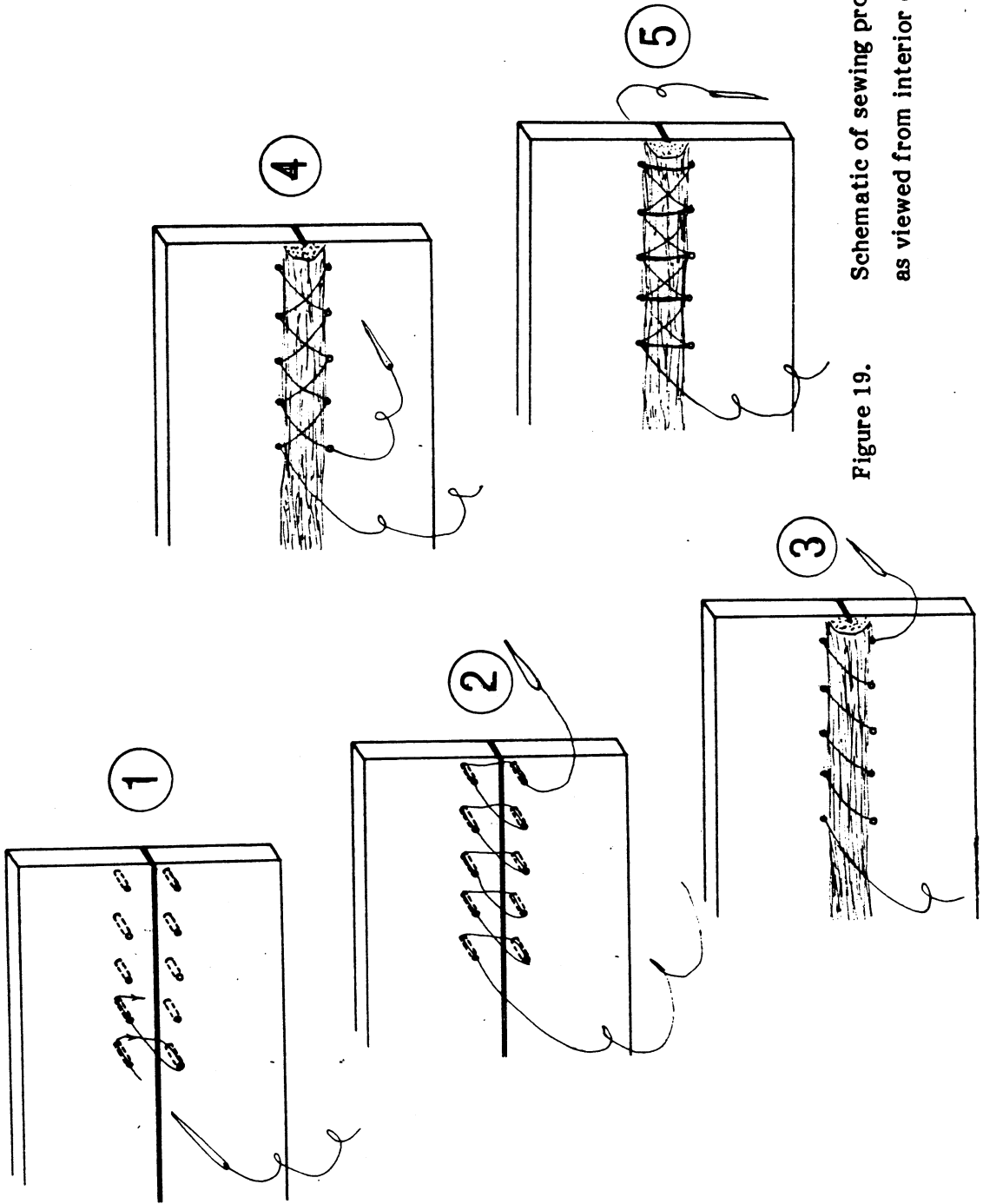

Figure 19. Schematic of sewing procedure as viewed from interior of hull.

The sternpost of the mtepe was made of a single timber. It was attached to the vertical face of the after end of the keel by a few lashings. No other method of fastening was used between the sternpost and keel (Fig. 20).

The stem post was constructed in two pieces. The scarf that joined these timbers was unique. The uppermost timber of the stem post had a tongue which was set into the female slot at the top of the lowermost timber (Fig. 21).

This uppermost portion of the stem post curved forward and terminated in a point, and it was this beak-like prow that was the mtepe's most characteristic feature. Besides having a distinctive shape the prow was decorated with incised carvings of geometric patterns and a stylized oculus. This prow, when painted red, black, and white, was the signature of the mtepe and has been the focal point of discussion regarding the origin of the mtepe. The beak-like prow facilitated the mounting of several flags along its crest and a row of fringe, or "camel's beard" (Hornell, 1941:57), was hung beneath this projection. The final "decoration" was either an amulet or tassel that hung from the tip of the prow (see Fig. 10, p. 24; 8, p. 21; 13, p. 28; 9, p. 22). This stem post was butted to the keel in the same manner as the sternpost, with only a few lashings. The base of the stem post had a slight concavity. It was mated to the end of the slightly convex keel. The configuration formed a quasi "ball and socket" juncture (Fig. 22).

The details of how this highly decorated stem post or sternpost was fastened to the strakes are unclear. This area on the exterior of the hulls was obscured by caulking in all models and photographs. A definitive statement cannot be made, but the similarly constructed sewn boats at Ras Hafun "appear" (Chittick, 1978:4) to have their strakes fitted into a rabbet. Although one model shows stitching holding the strakes at the apex of the stern, in my opinion the strakes were secured to the stem and sternposts with dowels and stitching. Based on structural necessity, the strakes were probably set into a rabbet on the posts (Fig. 23).

The size of the strakes and their scarfing pattern is critical in understanding the function of a shell-first sewn hull. Dimensions for the strakes are once again difficult to quantify; qualitatively they have been referred to as very wide and "about 3 thick" (Field, 1925:524). A clue to the width of the strakes may be the sided dimension of the keel. From the cross-sectional profile of the keel it appears that it was sawn radially from its original timber. If this is the case, the strakes may have been manufactured at the same time and from the same timber as the keel. Although this is conjecture, the practice was a common one. This

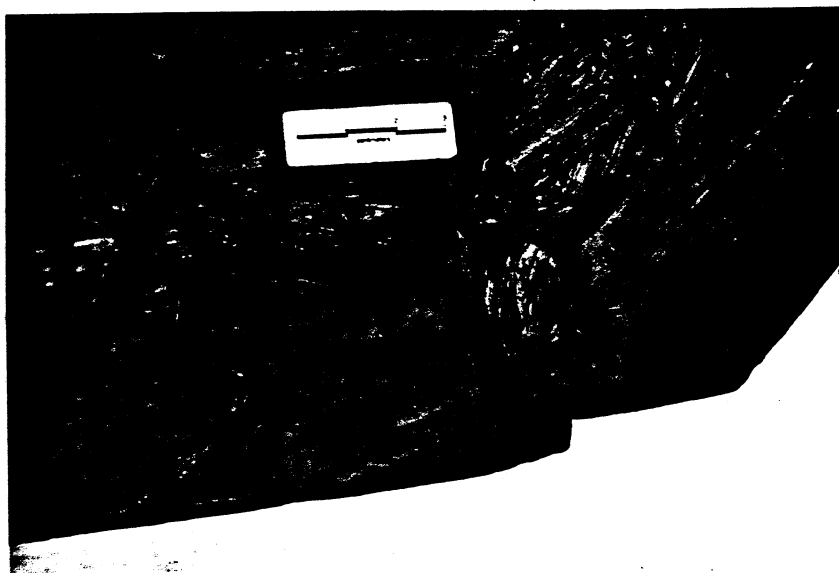

Figure 20. Juncture of keel and sternpost.



Figure 21. Male-female scarf of stem post.

"Dhow-Mtepe - presented by Commander W. G. Murphy-King", Fort Jesus Museum, Mombasa, Kenya.



Figure 22. Juncture of keel and sternpost.

"Bajun Mtepe - made for Sir Mbarak bin ali Hinawi", Fort Jesus Museum,
Mombasa, Kenya.



Figure 23. Stitches at apex of stern.

"Bajun Mtepe - made for Sir Mbarak bin ali Hinawi", Fort Jesus Museum,
Mombasa, Kenya.

supposition could be verified by comparing keel and strake grain patterns if any archaeological example became available.

The pattern in which these planks were scarfed to form each strake is consistent with the principle of flexibility. All of the models show a simple non-locking diagonal scarf, and the one photograph (Fig. 24) which shows some detail of the planking pattern has only diagonal non-locking scarfs.

After the addition of the stem and sternpost, the construction of the shell-first hull continued up to the waterline. Next, interior components were added to the vessel. The term interior components will be used in this thesis as a collective term for the features that are independent of the hull but additive to its competency. The interior components were the frames, stringers, and partial decks - fore and aft (Fig. 25).

The first of these components to be added to the hull were the frames. They were of compass timber, and for a mtepe of 40 ft length were 5" in diameter (Field, 1925:524). There are no references to frame spacing, although Figures 27 and 28 show the pattern, without scale. The spacing appears to be wide. The only other indicator of the frame spacing is the interval between the penthouse railing stanchions, which are lashed to the sides of the frames.

The framing pattern from amidships both fore and aft was floor timbers with futtocks. Approaching both bow and stern this pattern was followed by half frames. Then, nearest the bow or stern, full frames were used and were either reduced in size or canted to fit the narrowing hull. The farthest forward member and, occasionally the farthest aft, were inverted and appear as horseshoe-shaped thrubeam with ends protruding through the hull (Fig. 26). The arched thrubeam in the bow served as the point of attachment for the forward anchor line (Fig. 29).

The scarfing pattern from floors to futtocks in the midships area utilized a simple scarf. In actuality, the term scarf is not accurate as there is no direct or indirect connection between the two members - no lashing or doweling of any kind. It is also noteworthy that the pattern of these butt scarfs from amidships forward was opposite to the pattern from midships aft. Details of the scarfing pattern can be seen in Figure 30.

The only fastening securing the frames to the hull was a simple lashing that criss-crossed over the frame to form an X pattern. It was secured to the hull in the same manner as the planks were sewn, with dowels securing the lashing. The frame was held in position with only a few of these double stitches (Fig. 31).



Figure 24. "Close up of hull planking of dau la mtepe" - photo by R. C. Gilfillian Esq., Fort Jesus Museum, Mombasa, Kenya.



Figure 25. Interior components - Frames, stringer, and partial desk.

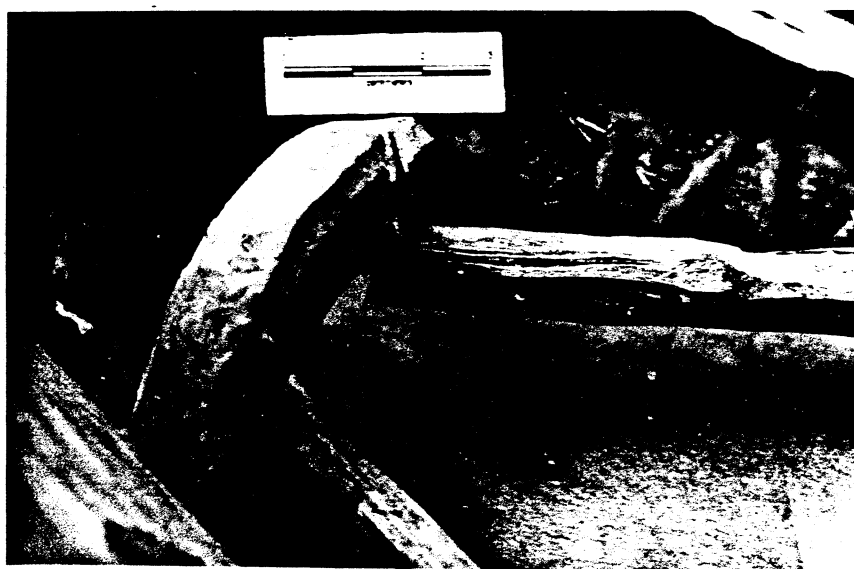

Figure 26. Forwardmost arched thurbeam
"Dhow-Mtepe - presented by Commander W. G. Murphy-King",
Fort Jesus Museum, Mombasa, Kenya.

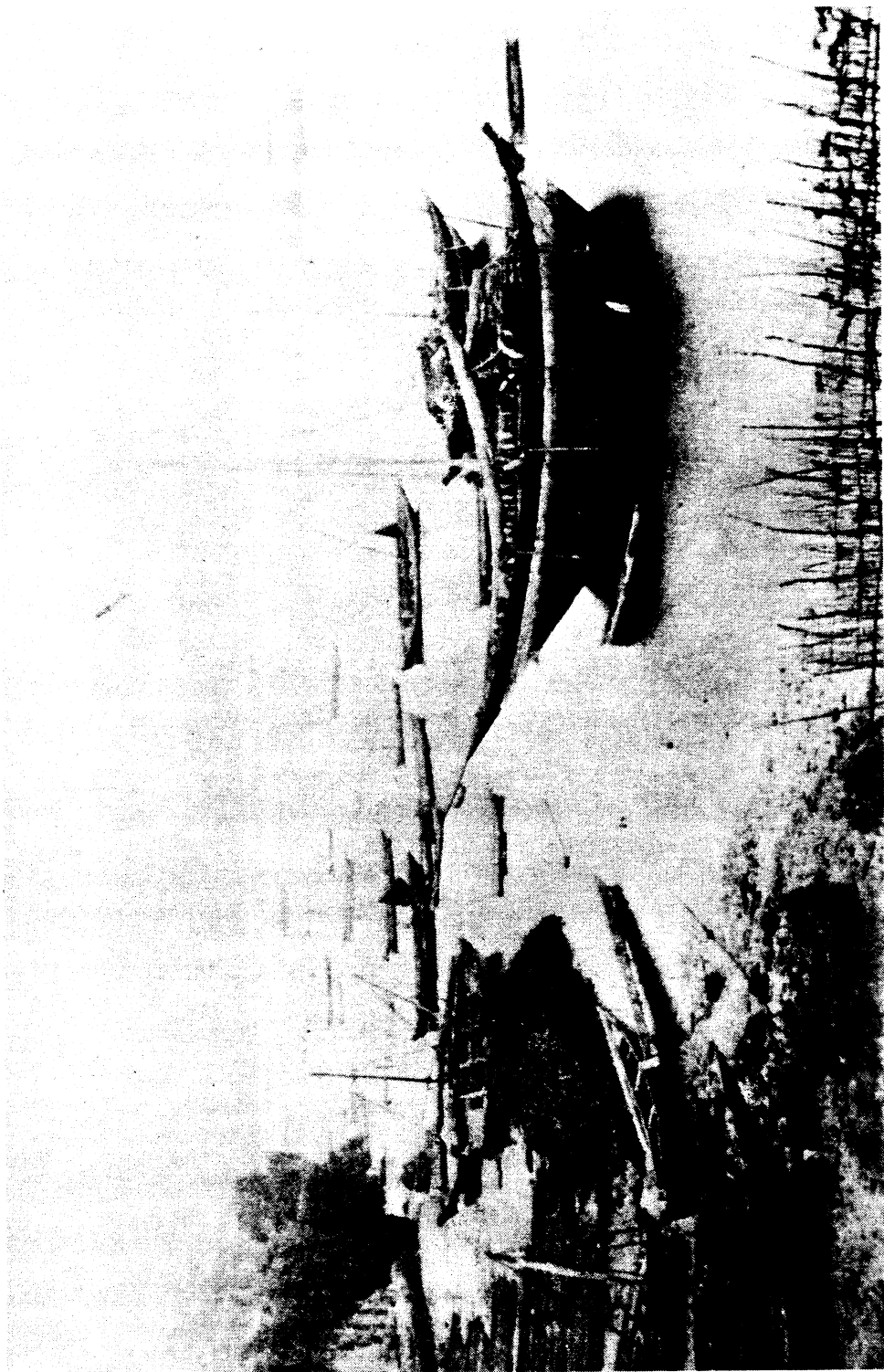

Figure 27. "Two dau la mtepe's at low tide in Mombasa Harbor", Fort Jesus Museum, Mombasa, Kenya.

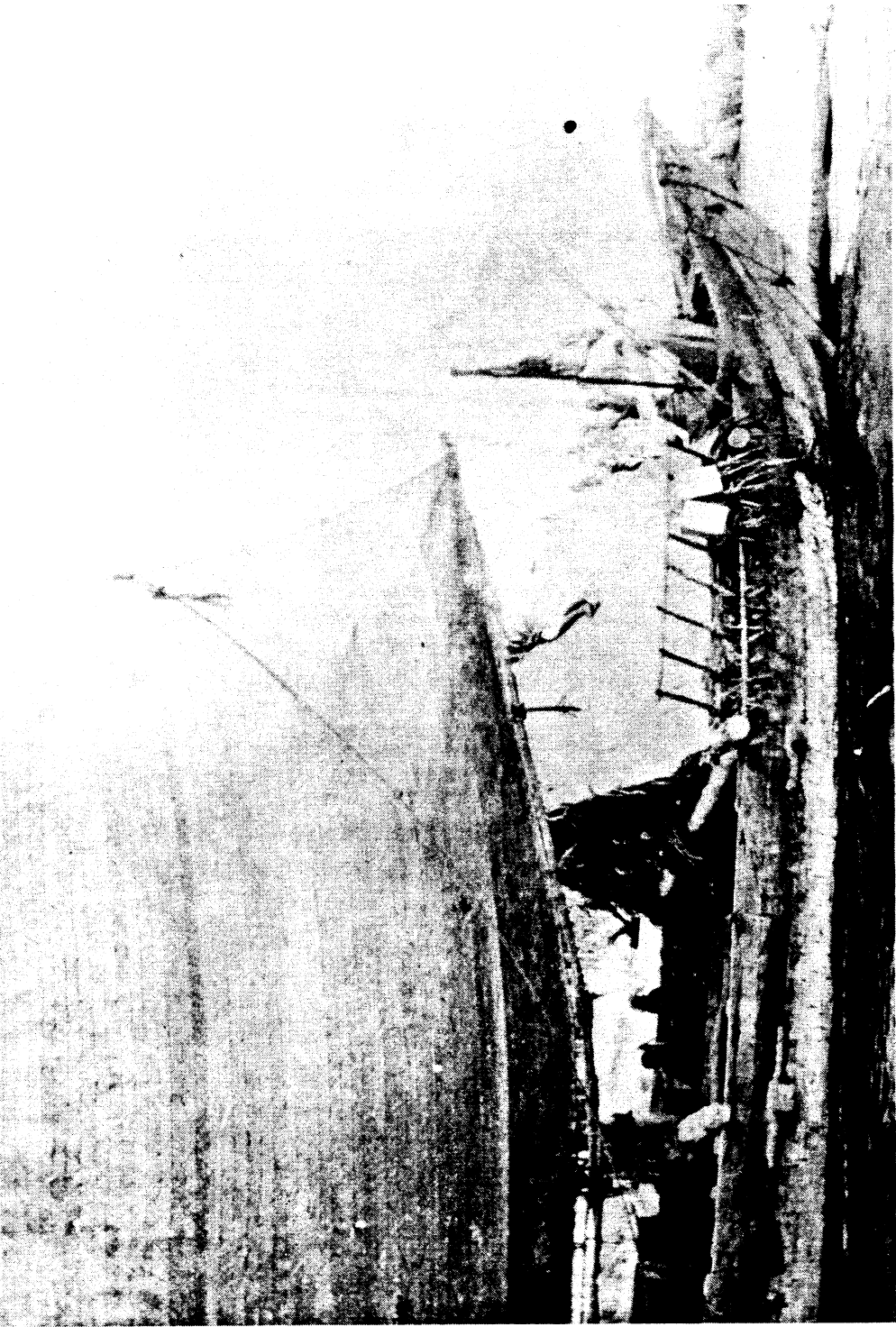

Figure 28. "Aft portion of dau la mtepe 1917", photo by R. C. Gilfillian Esq.,
Fort Jesus Museum, Mombasa, Kenya.

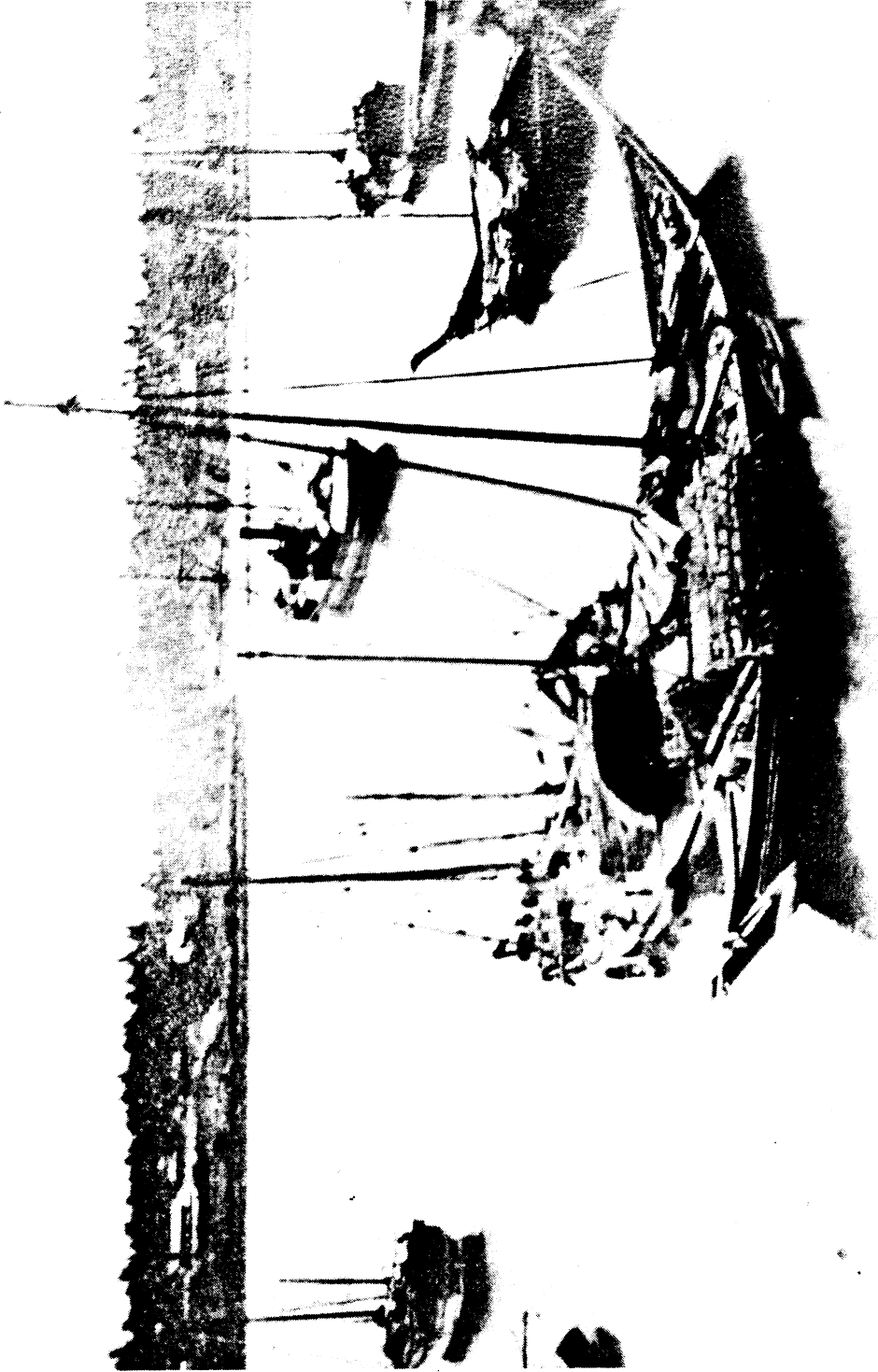

Figure 29.

"Several Mtepes at anchor", from an album of Ron H. K. (1875-1923), CMS missionary in Mombasa, Freretown & Rabai, Fort Jesus Museum, Mombasa, Kenya.

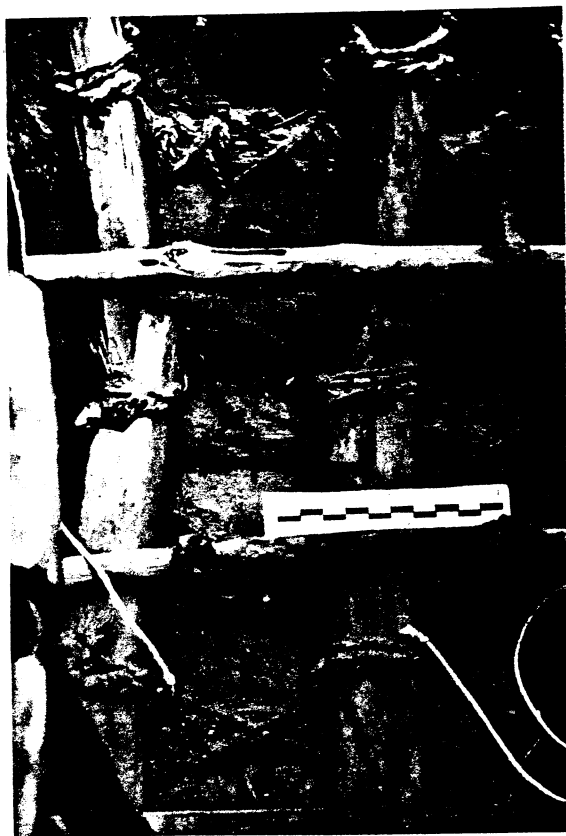

Figure 30. Detail of frame scarf pattern forward of amidships.

"Bajun Mtepe - made for Sir Mbarak bin ali Hinawi", Fort Jesus Museum,
Mombasa, Kenya.



Figure 31. Stitching pattern used to secure frames forward of amidships.

"Bajun Mtepe - made for Sir Mbarak bin ali Hinawi", Fort Jesus Museum, Mombasa, Kenya.

The stringers were the next interior component to be fitted. They were single timbers, round in cross section, and smaller in diameter than the frames. The number of stringers used in each boat varied; either four or six (2 or 3 per side) were used, as shown in the models. These stringers were held in place with single stitches taken in a few locations along the hull. Each stitch was taken over the stringer and doweled to the hull (Fig. 32).

The stringers were independent, connected only superficially to the frames. Several stringer positions have been noted. The uppermost was just atop the partial decks fore and aft and resting on the top side of the nether thwarts. The lowest position observed for the stringers, when three stringers were present per side, was at the level of the top of the mast step. This position can be seen in Figure 33. The placement of the uppermost stringer can be noted in Figures 27 (p. 45), 29 (p. 47) and 11 (p. 25).

Before the last and uppermost stringer was added to the hull, the lower or nether thwarts were set in place. These slightly squared timbers served to couple the sides of the hull.

From the models and the photographs, we know that five or six nether thwarts were used in hull construction. To integrate these thwarts with the hull, boat builders notched their lower surfaces to accommodate the hull planking, leaving several inches of the thwarts protruding from the exterior of the hull (Figs. 34 and 28 on p. 46).

Both the exterior and interior of the hull where the nether thwarts passed through were caulked in the same manner used to cover the interior planking seams. It appears from the models that builders drilled through the thwarts to allow the caulking and sewing procedure to continue without interruption (Fig. 35). However, there is not quite enough evidence to verify this procedure, and from Figure 28 (p. 46), it does not appear to be the case. It looks as if the caulking may only go around the outside of the thwart, with no stitching penetrating the thwart itself.

When all of the nether thwarts were in place, two more strakes were added to complete the planking of the hull. After the uppermost strake was in position, the upper thwarts were set in place directly over the lower thwarts, forming matched pairs of thwarts. To complete the hull, a final lashing was added by passing a line around the matched thwarts several times and pulling it taut. Then to further increase tension on the lashing, another line was bound tightly around its center to

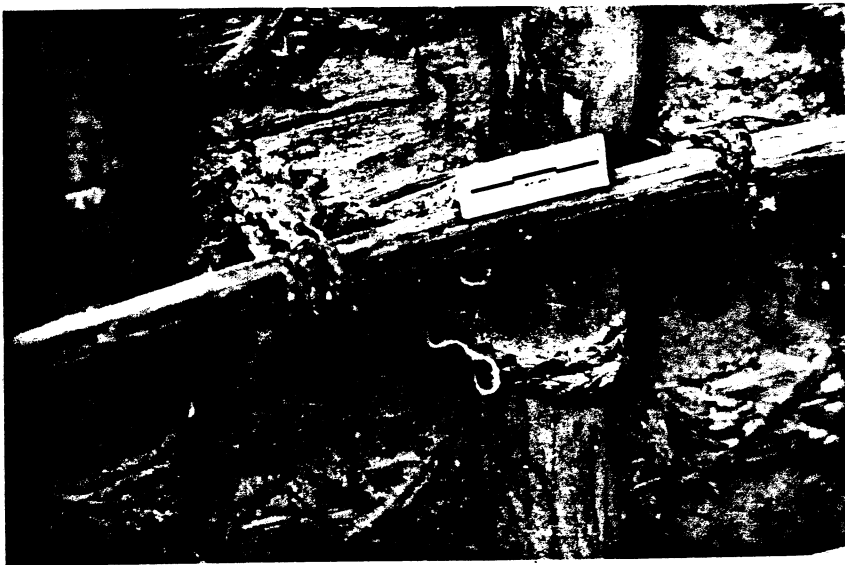

Figure 32. Stitching pattern used to secure stringers.

"Dhow-Mtepe - presented by Commander W. G. Murphy-King",
Fort Jesus Museum, Mombasa, Kenya.

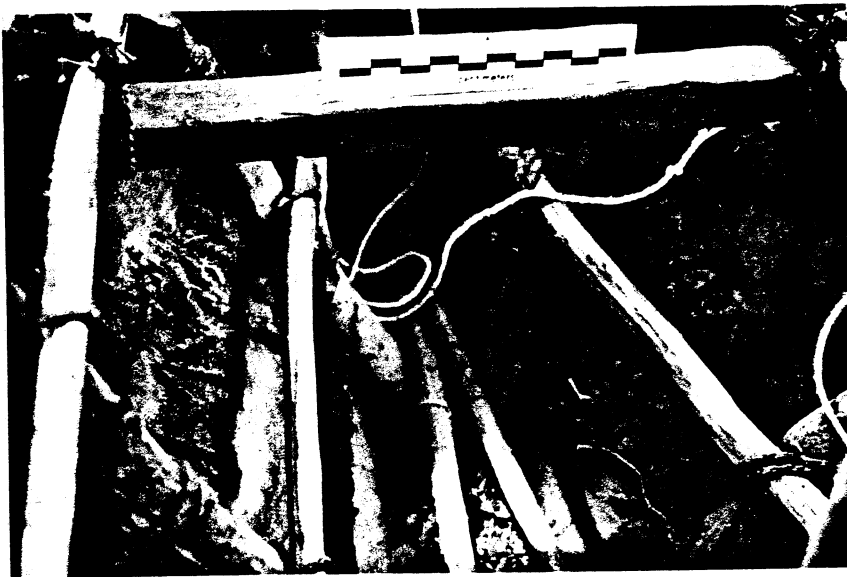

Figure 33. Position of stringers in hull.

"Bajun Mtepe - made for Sir Mbarak bin ali Hinawi", Fort Jesus
Museum, Mombasa, Kenya.

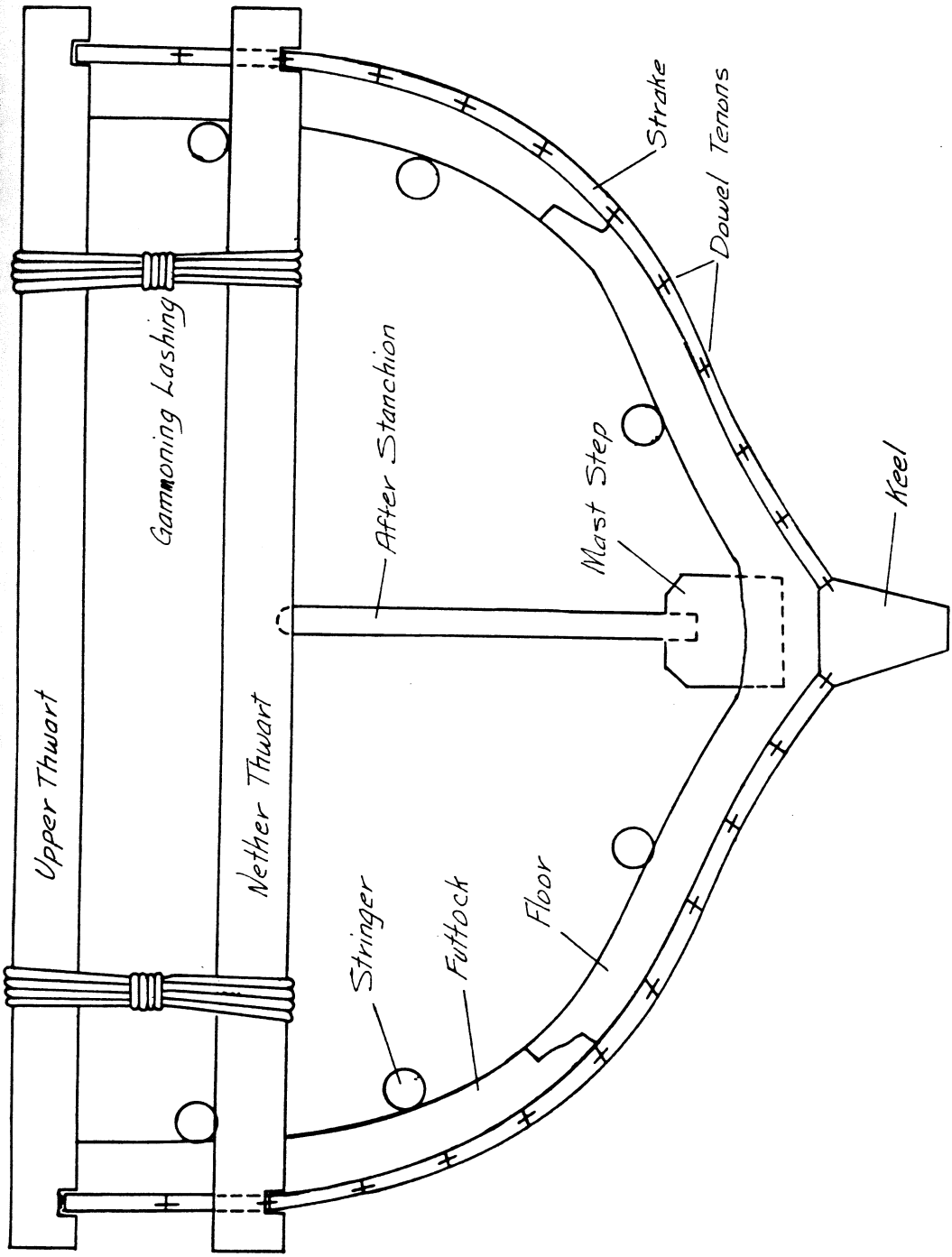

Figure 34. Cross-section of hull.

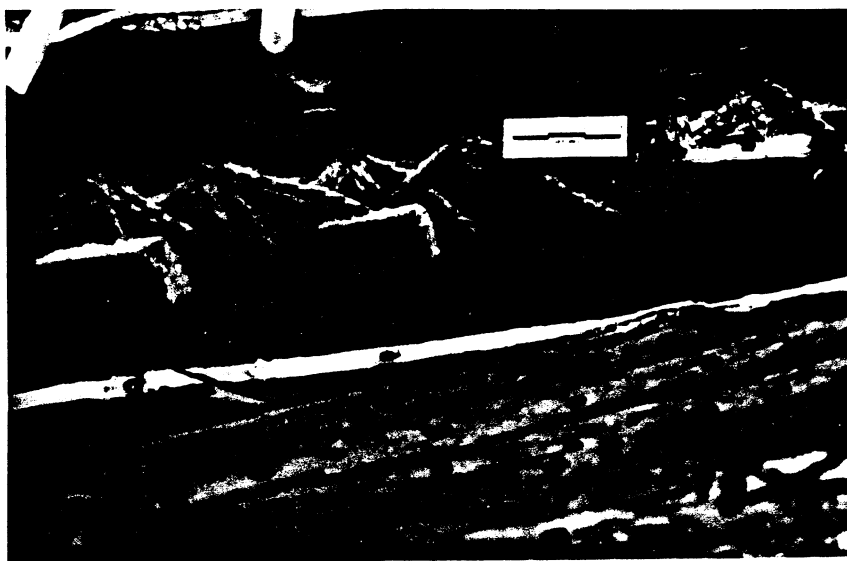

Figure 35. Sewing pattern of external caulking.

"Bajun Mtepe - made for Sir Mbarak bin ali Hinawi", Fort Jesus Museum, Mombasa, Kenya.

pull the sides of the lashing tighter. This type of lashing is essentially the same as that used on 18th century European vessels to secure the bowsprit to the beakhead, and is termed "gammoning" (Falconer, 1970)(Fig. 36)..

The final interior components to be added were the partial decks at the forward and after ends of the boat. These decks extended from the apex of the bow or stern to the first nether thwart encountered on either end, and their decking was arranged along the axis of the boat. These decks were structurally as well as operationally functional. The structural purpose will be discussed in the chapter Hull Analysis. The operational purpose of the decks was fairly simple; the after deck served as a platform to aid in steering the vessel and the forward deck in the apex of the bow facilitated handling of the forward anchor. With the decks installed the hull was finished; its construction, from the time the timber was harvested to the time the boat was ready to sail, was completed in a mere two to three months (Hornell, 1941:59).

A quote from Field (Sept. 24, 1925:524), aptly sums up the construction of the hull.

"When it is considered that no measurements are taken, that the building of the whole structure is directed solely by the chief fundi's eye, and that the tools used are crude and few in number, it is remarkable how beautiful and symmetrical are the lines and how true they remain to the type."

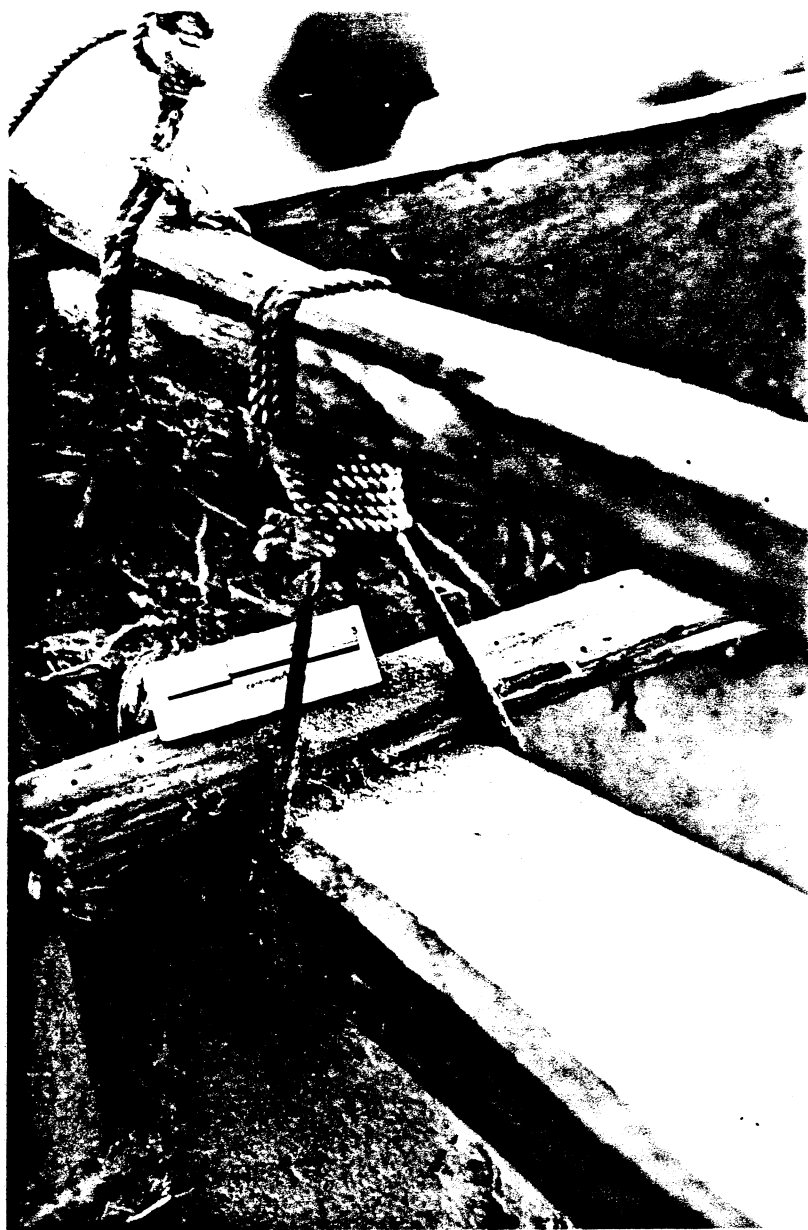

Figure 36. "Gammoning" lashing between thwarts.

"Dhow-Mtepe - presented by Commander W. G. Murphy-King", Fort Jesus Museum, Mombasa, Kenya.

CONSTRUCTION AND ANALYSIS OF THE MAST ASSEMBLY, SAIL, AND RIGGING

After completion of the hull, the mast and associated components were added to the boat. The design for the mast, sail, and rigging had to fit several criteria. The primary requirement was that the mast, sail and rigging would not functionally obstruct the carefully-designed hull, and ideally, that they would enhance its structural competence. Another design consideration was efficiency. Simply stated, the mast is responsible for the support of the propulsion surface. The larger the surface, the faster or more efficient the vessel. Following this line of reasoning and applying it to the design of the mast, the mast needed to be as large as possible to support as great a sail area as possible, to effect optimum efficiency.

With those principles briefly stated, it is necessary to diverge from description and analysis of the mast, sail, and associated rigging to typify the sail the mtepe used, and to eliminate a few preconceived ideas about it. The sail that was used on both the mtepe and the dau la mtepe was a square sail. Researchers' consensus, based on ancient to modern examples, is that square sails and vertical masts are part and parcel. Indeed, several descriptions of the mtepe in academic literature have referred to its vertical mast. Among these authors were Hornell (1941) and Prins (1965) in deductions possibly made from hasty observation of the Science Museum model. But models, actual observation, and measurements taken from the archival photographs indicate that the mast is canted forward six to fourteen degrees. The practice of canting the mast forward has previously been linked to ease of handling lateen sails, the dominant sail type throughout the western Indian Ocean. As there is no need to "wear around" (Bowen, 1949:126-127) with a square sail, there must be another reason for the mast of these vessels to be canted forward.

The base of the mast assembly, the mast step, was fitted into the bilge of the boat. It was centered fore and aft along the axis of the boat and its underside was notched to fit over the frames. This timber or mast step has been identified in the literature as a keelson (Prins, 1965:121, Diagram XI) (Fig. 37). This term, I believe, was incorrectly applied, as the timber did not span the length of the vessel, was not fastened to or integrated with the keel in any fashion, and was not attached or even lashed to the frames. It served only to distribute the weight of the mast. The

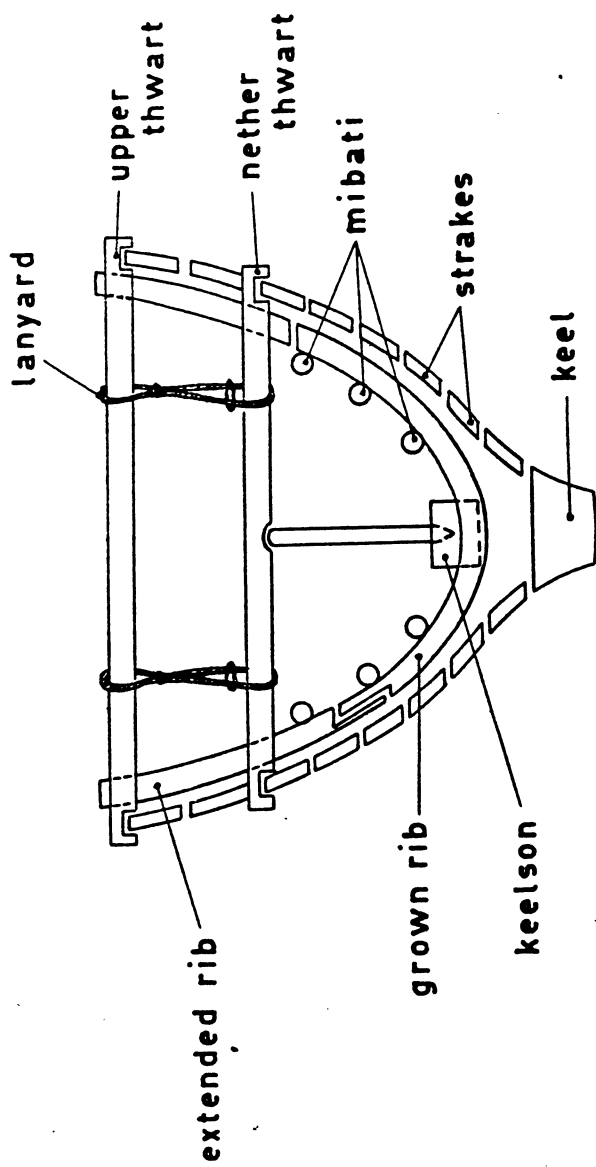

Diagram XI - The mtepe: section forward of amidships

Figure 37. Mast step incorrectly identified as keelson, Prins (1965):188.

length of this step is uncertain; the models are the only source available for defining this dimension, and they are regarded as somewhat inaccurate. All that can be said is that the mast step spanned a minimum of six frames and probably covered no more than seventy percent of the length of the vessel.

The mast was adzed at its base to fit a square mortise in the mast step. It was canted forward where it rested against the upper thwart of the matching thwarts located just forward of amidships. The lower thwart was either notched or built up to form a cradle for the mast, which prohibited its lateral movement. The mast was further secured to a stanchion that was set into the mast step on the forward side of the upper thwart on which it was leaning. The lashing that secured the mast to this stanchion was the same type of "gammoning" that was used to compress the upper and lower thwarts. It was placed just above the upper thwart and was kept from slipping off the top of the stanchion by a notch cut around the stanchion near its top (Fig. 38). To complete the mast assembly, another stanchion was located near the after end of the mast step. It joined the after end of the mast step to the bottom of the nether thwart located at the forward end of the deck shelter or penthouse (as it has been referred to in the previous literature) (Prins, 1965:122) (See Fig. 39.)

An analysis of the mast assembly and the functions of its components shows that the mast step served to distribute the weight of the mast, and interfered little with the flexibility of the keel or hull of the boat. The lower thwart inhibited lateral movement of the mast. The after securing stanchion held the after end of the mast step in position. The forward securing stanchion stabilized the mast and provided a relatively simple means of unlashng the mast during maintenance of the vessel. The purpose of canting the mast forward was to relieve a portion of the downward force or weight of the mast on the keel. In so doing, the weight was transferred to the uppermost thwart and consequently to the bulwarks of the boat. This added weight of the mast on the upper thwart increased compression between the bulwarks and that portion of the hull that is under water. Or in physical terms, a portion of the gravitational force was removed from the bottom of the hull or mast step, and transferred to the bulwarks where its force opposed the buoyant force and increased the competence of the hull (see Fig. 40, Qualitative Vector Analysis).

As a result of canting the mast, when the boat was under sail, a portion of the force of the wind against the sail would be transferred to the thwart against

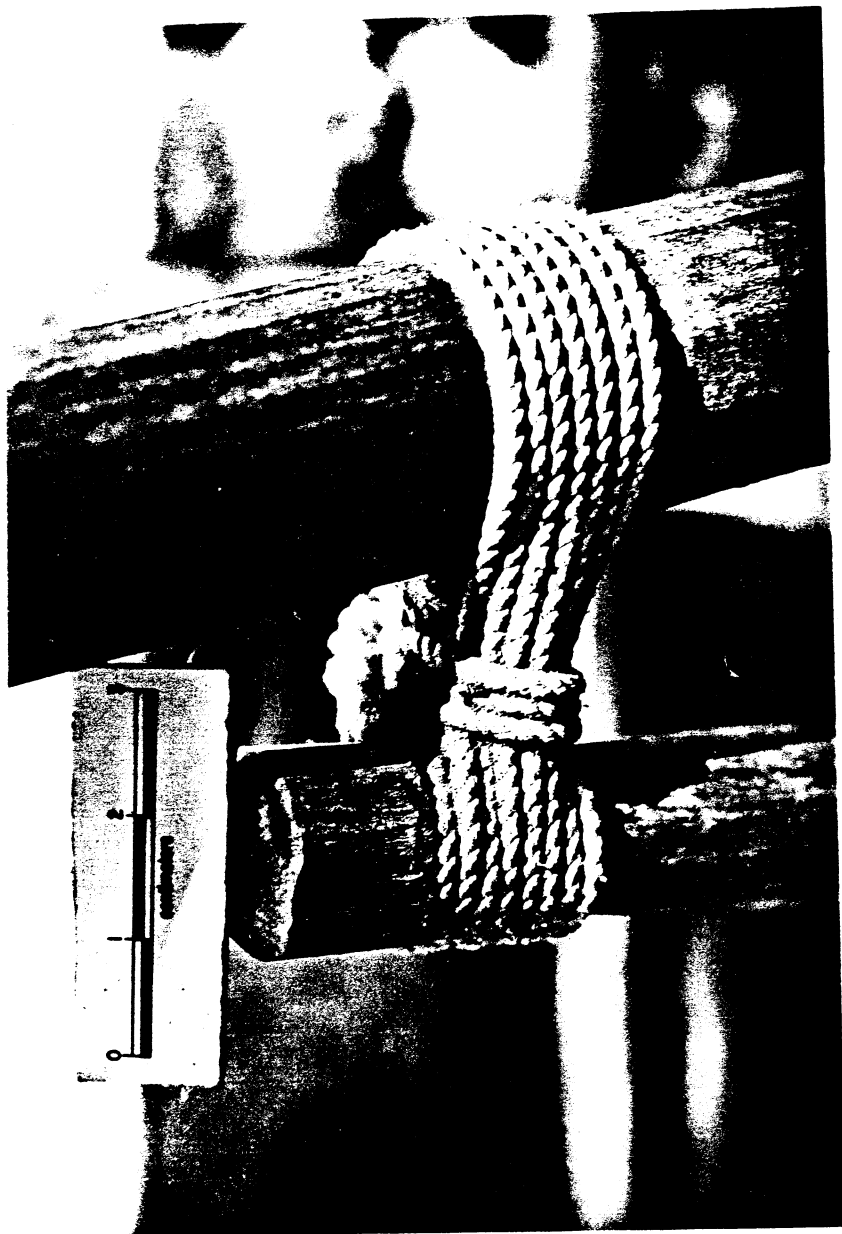

Figure 38. Mast assembly showing "gammoning" lashing.
"Dhow-Mtepe - presented by Commander W. G. Murphy-King", Fort Jesus
Museum, Mombasa, Kenya.

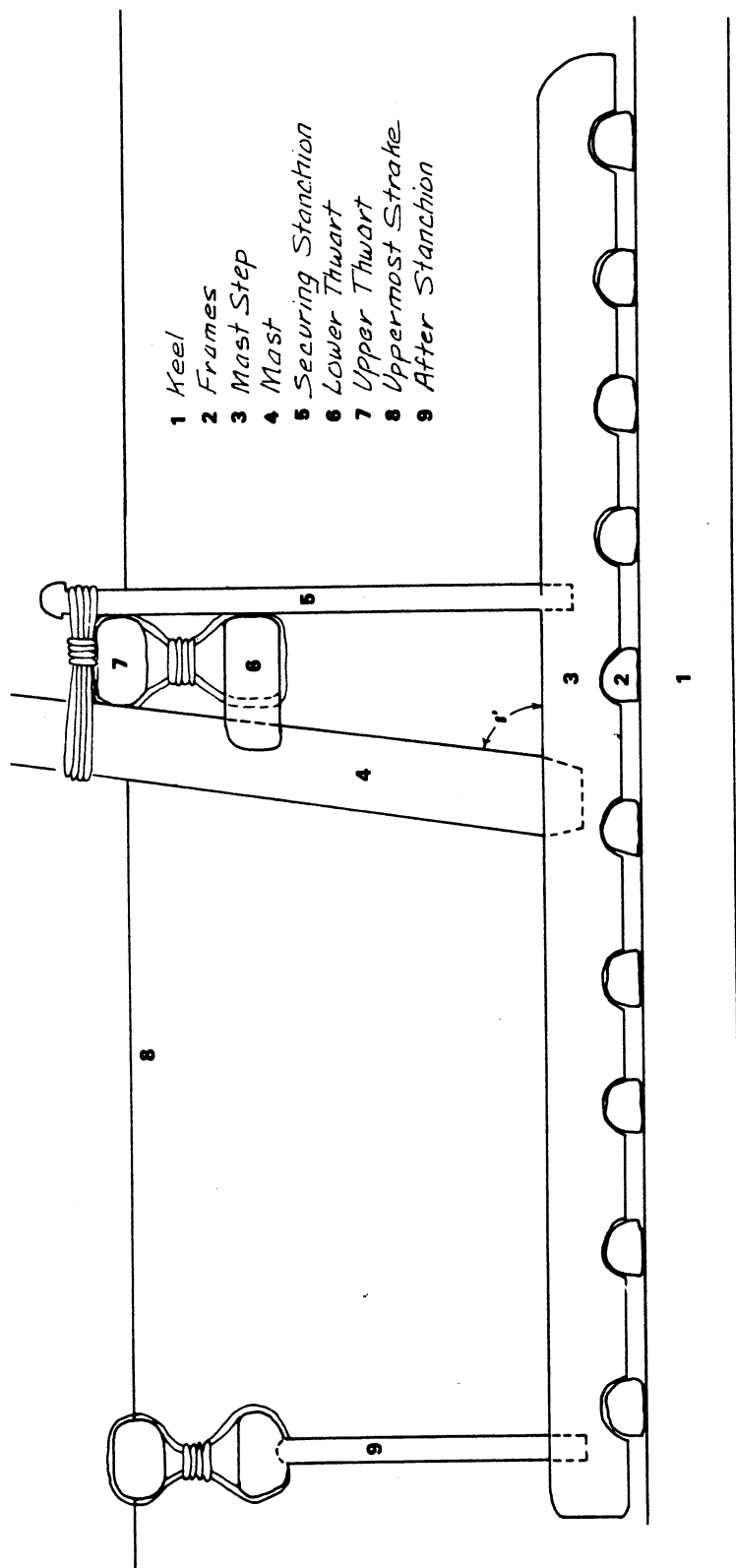

Figure 39. Mast assembly.

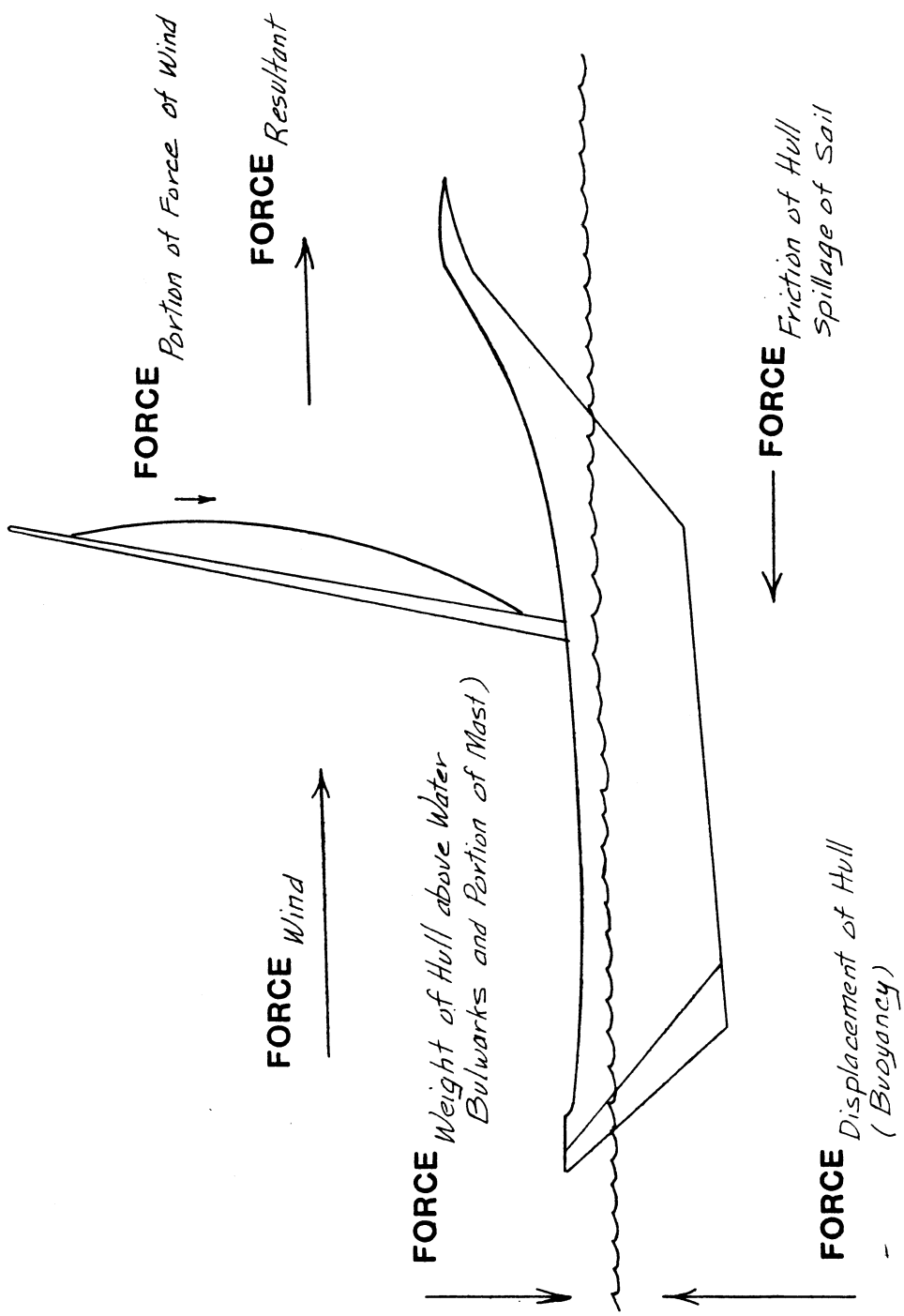

Figure 40. Qualitative vector analysis of forces exerted on vessel while sailing.

which the mast was cradled, and consequently to the bulwarks as a downward force. So, as the wind or force on the sail, the speed of the boat, and the stress on the hull increased, so would the downward force on the bulwarks, resulting in increased compression of the bulwarks against the portion of the hull that was under water. Therefore, the hull was essentially self-tightening or self-compensating.

The standing rigging of the mtepe consisted of a single forestay that ran from the masthead to the top of the prow, and of two backstays secured to one of the upper thwarts near the stern. The mast had either one or two shrouds. Although I have seen two shrouds on all models and photographs examined, Hornell mentioned the use of one shroud, and attributed it to the reliability of monsoon winds from a single direction during the sailing season (Hornell, 1941:59). These shrouds were secured to an upper thwart by a toggle run through a closed loop, with the free line wrapped around this toggle (see Fig. 41).

The running rigging of these boats was inaccurately drawn in several early references. These mistakes were corrected by Hornell in his 1941 article. I have found his description of the running rigging to be accurate and in need of no further revision. Hornell's description is as follows:

Both types are square-rigged, the sail of matting made of plaited strips of the leaflets of the mkoma palm, sewn together. Its head is tied at intervals to an upper yard and the foot to a lower spreader yard or boom. It is hoisted to the masthead by means of a halyard supplemented by two lateral tackles which combine the functions of lifts and braces and may therefore be termed "lift-braces". The upper end of the halyard is rove through a sheave-hole some way below the masthead and made fast to the middle of the yard. Each lift-brace functions through a purchase fitted between the masthead and one end of the yard, a tackle consisting of two single blocks. One end of the rope is rove through the block at the end of the yard, passes to the block at the mast and returns to be made fast to the yard-arm just inner to the first block. These lift-braces, as the name implies, also control the set of the yard; by slacking away on one and hauling on the other, the yard is veered. The lower yard or boom is controlled in turn by two sheets and a windward tack, while a bowline from a cringle on the fore leech is rove through a dead block on the prow and belayed round the first thwart. A parrel holds the yard to the mast, with the boom similarly held in by a light rope loop (Hornell, 1941:58-59).

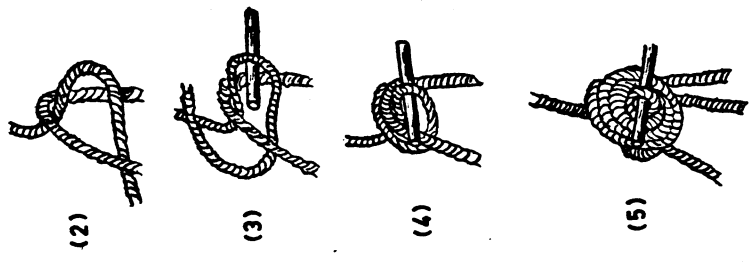
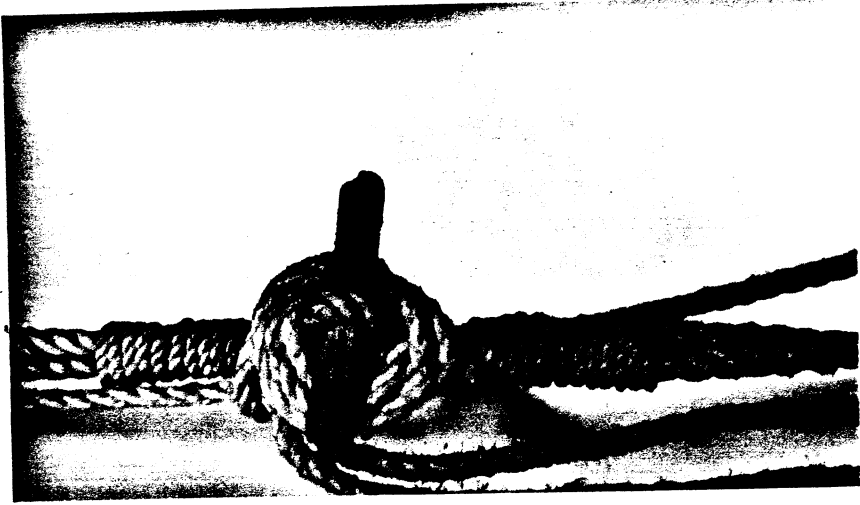

Figure 41. Photograph and schematic of method used to secure shrouds, from Prins (1965):120.

"Bajun Mtepe - made for Sir Mbarak bin ali Hinawi on loan from Municipality of Mombasa" (dau la mtepe), Fort Jesus Museum, Mombasa, Kenya.

Because no metal fastenings were used anywhere in the construction or rigging of the mtepe, the method in which the lift braces were secured to the mast is an important feature of the running rigging and worthy of description. The area where the sheave is located and where the halyard runs through the mast is a bulbous swelling. Whether the swelling is natural or not, it served a dual purpose: it provided a location for the sheave and also facilitated attachment of the lift braces. Attaching the lift braces was accomplished by the simple procedure of placing a loop of line, just large enough to fit, over the mast head and sliding it down until encountering the bulbous swelling of the mast. This feature is important when maximum height of mast, maximum strength, and maximum attainable sail area are postulated. The bulbous swelling and the method in which the lines were attached resulted in the strongest possible mast; as it had not been pierced with fasteners of any kind, the hole for the sheave was probably being made through a natural knot area (see Fig. 42 oversize illustration at end of text).

The sail of the mtepe was not made of cloth but of matting woven from the mkoma palm (Lydekker, 1919:88). Palm leaves were first plaited into narrow strips a few inches wide. Then the strips were woven together to form the sail (Fig. 43). Details of sail construction can be seen most clearly in archival photographs Figures 28, (p. 46) and 44. The actual size of a sail has been recorded as 30 feet in height and 40 feet in width (Field, 1925:524). Unfortunately, these are the only dimensions from first hand observation, and the other dimensions of the vessel were not accurately described. Measurements from the replica models, Figures 7, p. 19, 44 and 45, indicate that the sail was almost square; and comments from several sources characterized it as "huge" (Pearce, 1920:30).

The speed of a vessel is a direct result of efficiency in design. In other words, a very fast boat like the mtepe is not swift by accident. The limiting factor in the speed of a vessel, irrespective of hull design and stability, is the amount of sail that can be carried. The amount of sail that can be carried is a function of how much weight the mast can support. We have already seen that the mast was carefully designed to distribute the weight and force placed on it. Two components were supported by the mast: the sail and yards. As the sail was the propulsive area, the yards had to be as small as possible, since their primary function was to spread the sail. To accomplish this, the size of the yard could be made thinner and longer, to the point where it began to flex and could not even be lifted at the center. To achieve this long thin upper yard, two or three poles were fished

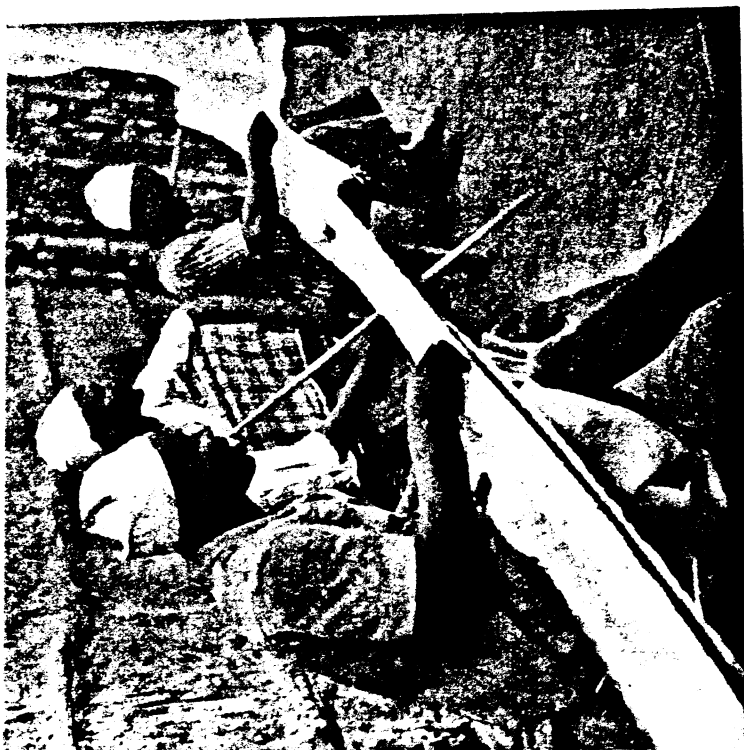

Figure 43. Plaiting strips of palm fiber.

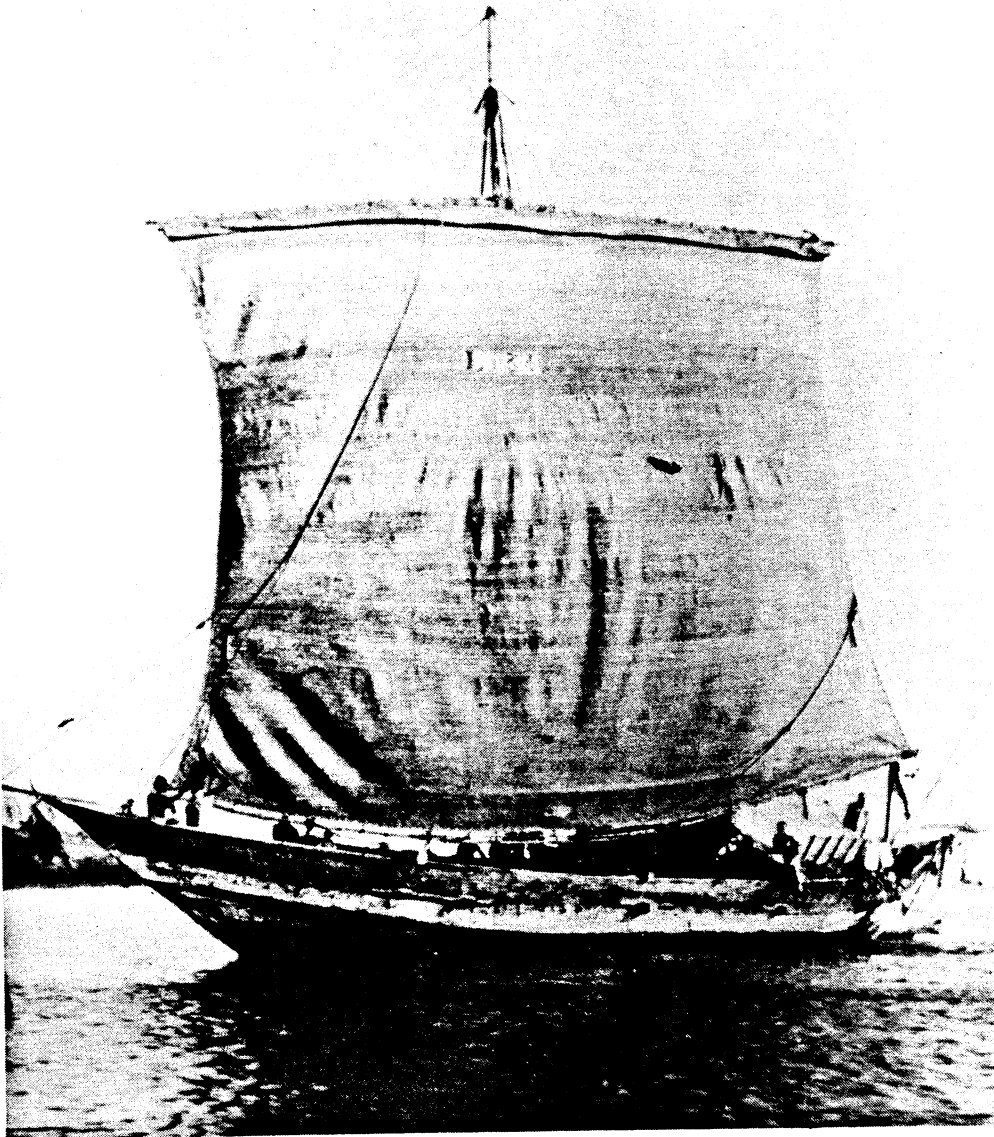

Figure 44. "Dau la mtepe under sail 1917", photo by R. C. Gilfillian Esq., Fort Jesus Museum, Mombasa, Kenya.



Figure 45. "Dau La Mtepe, as seen at Mombasa Old Port in the early 1920's",
John Jewell Dhows at Mombasa, p. 77.

together. To raise this yard with the sail to the masthead, it had to be hoisted from three points, the ends and the middle, at the same time. This was the reason for the introduction of the lift braces that assisted not only in hoisting the sail but also in trimming it. This seemingly flimsy arrangement enabled the length of the yard to increase, with a minimal increase in weight. Consequently the sail area increased as well, allowing the vessel to achieve great speed.

If the preceding analysis is correct, the result would have been a vessel at or near its maximum efficiency, manifested in terms of speed. Fortunately, many of the early explorers and visitors to the East African littoral, who had seen the mtepe or its descendant under sail, remarked on its performance. Among the plaudits were the comments of Pearce (1920:30): "They sail remarkably well close hauled and the huge mat sail is managed most deftly by the crew." Other praise of the vessel's sailing ability, compared to that of the swift Arab dhows that plied the coast, was that the "dau la mtepe was able to hold her own with ease" (Jewell, 1969:77). An early explorer of the coast indicated they are "very swift and sail much closer to the wind than most vessels" (Owen, 1833:384). Even higher praise was bestowed on the performance of these boats by the article in Field (1925:524), which states that "They sail closer to the wind than any other type of vessel on the coast". It is the common belief that the lateen fore and aft rig was able to sail as close to the wind as any vessel, but Hornell, in his commendation of the mtepe, said, "But those who knew the mtepe (among them Sir Richard Burton) have maintained stoutly that the sambuk type, hoisting a lateen sail, is inferior in speed to the square rigged mtepe and dau, nor can it point so close to the wind" (Hornell, 1941:55). It appears that the sail with its bowlines, upper and lower sheets, and, at least in some cases, the presence of reef points, allowed for very precise trimming of the sail and great efficiency.

The references are overwhelming in their praise for the sailing capacity of this particular rig. These statements confirm that this vessel was fast and efficient as a result of its rig. The design which produced this efficient sail system may have been a relatively recent innovation, but a more plausible explanation, considering the antiquity and efficiency of the hull and mast assembly, was that the design was the product of thousands of years of refinement.

HULL ANALYSIS

With the construction of the hull completed, it is the purpose of this chapter to analyze hull construction. The sewn hull did not have some of the components used in the western boat building tradition. These were primarily structural components. The mtepe had no wales, keelson or metal fasteners, and most of its components were fastened to each other with only a few simple lashings. In this thesis it is assumed that these components were not missing but that the hull was designed to function without them. The conclusion is that the vessel was designed to be flexible. This conclusion is supported by the observation of early visitors to the area that the sewn boats of the East African littoral were "loosely made" (Barbosa, 1918:14) and their "elasticity allowed them to stand a good deal of hard usage" (Ingram, 1931:304). The principle of flexibility will be used as the basis for analysis of the hull.

Analysis was both quantitative and qualitative. Quantification requires accurate dimensions, angles and complex mathematical formulas for presentation of a predictive model of the action of the sewn hull. Unfortunately, the sources used in the preceding definition afforded only a few accurate dimensions. The sources that could have been of great value--the models--were found to be accurate in detail but inaccurate in scale. Both bow and stern angles of the models are consistently higher than the actual angles of the boats measured from photographs. Furthermore, lines drawings taken from the models appear to indicate that they are foreshortened. These inaccuracies, coupled with the fact that dimensions of other components are unknown, make quantification extremely difficult. In a hull with a flexible design, the dimensions (e.g., thickness and width of strakes, number of fasteners, etc.) are critical in predicting its movement. These dimensions probably evolved over a period of many thousands of years. Until an archaeological example is recovered, analysis must be accompanied by the qualitative approach.

How much flexibility is there in the sewn hull? Unfortunately, little information is available for making a comparative assessment. Consider for a moment the Gokstad vessel. Although this 8th-century Viking ship is essentially incomparable because of its clinker style construction, lower freeboard, and dissimilar design, etc., there are certain comparisons that can be made. The

Gokstad vessel was constructed of wide planking and was about the same length as the average mtepe. The captain of a replica vessel reported that during his trans-Atlantic crossing in 1893 that the vessel was extremely flexible (Phillips-Birt, 1979:22). The Gokstad vessel has numerous fasteners, a feature which makes the vessel more rigid than the mtepe. If we consider the accounts that refer to sewn boats as being "loosely made" and having "good elasticity," and the disjoint configuration of keel, stem, and stern, it seems relatively safe to say that the mtepe or sewn boat was at least as flexible as the Gokstad boat and probably a great deal more so. This idea is reinforced by the practice of supporting sewn boats in an upright position when beached to prevent damage to the hull (Hornell, 1941:62, after A.C.M. Mullins).

The following analysis deviates somewhat from actual explanation of construction wherever it is helpful.

The foundation of the sewn boat was its keel. It is important to note that it is a single timber without scarfs, for even the keel is subject to flexing while at sea. This movement is evidenced by the stitching that secures the garboard strake to the keel (Fig. 46). This stitching, which was vertical everywhere else on the boat, was canted at the forward and after end of the keel to allow for movement of the vessel. Canting of the stitches allowed this movement in the same way that zigzag stitching allows clothing to stretch.

With movement or flex in the keel, a solid juncture or scarf to stem and sternposts would have been untenable. Both the stem and sternposts were simply butted against the ends of the keel and lashed to it. The lashing used to accomplish this task was nondescript, but the configuration is of some interest. This pattern served to focus the movement of the sternpost around a single point. The same configuration was also used to secure the stempost to the keel. The angles of the stem and sternposts were determined from photographs, the only accurate source. The results, although not exact, indicate that the angle of the sternpost, relative to the horizontal or water surface, was higher than that of the stempost. The angle of the sternpost varied from 42° - 52° and the stempost from 35° - 40° . The difference in these angles suggests two possibilities: (1) that they were determined by the placement of the master couple, or (2) that they were a result of the stem or sternpost being fitted to the pattern of planking that determines its angle.

Whether the angles of the stem and sternposts were the result of ease of construction or of the placement of the master couple may well be another

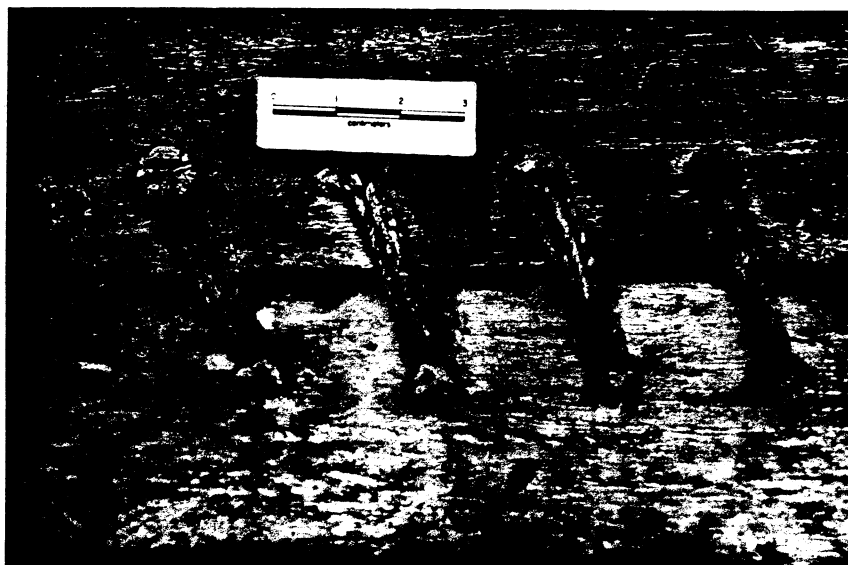

Figure 46. Canted stitching between keel and garboard near stern.

"Dhow-Mtepe - presented by Commander W. G. Murphy-King", Fort Jesus Museum, Mombasa, Kenya.

"chicken or egg" question. Indeed, the angles may have been dependent on neither, and may instead have been the result of thousands of years of refinements which were part of an effort to develop a hull of near racing proportions.

A final noteworthy feature of the stempost is its unusual scarf. The configuration, size and placement of this unusual male-female scarf offers further understanding of the flexible nature of the hull. Although the only representations of this scarf come from models, certain characteristics are apparent. The scarf is longer than seems necessary, and it is symmetrical about the long axis of the stempost. The fact that a scarf was used, when a single timber could have been, suggests a purpose for it.

The purpose of the scarf on the stem post is assumed to be related to the flexible movement of the hull. This scarf would be particularly well-suited to absorb forces from two of three directions.

To better understand the function of the stem post a schematic drawing shows how torque along its axis could be compensated for and how movement from side to side would be allowed. The only directions in which the stem post was not allowed to flex were fore and aft, as this would have separated the strakes from the stem post--a disastrous situation even for a sewn boat (Fig. 47).

It is necessary to understand the role that the planking played in the structure of the hull. In fact, the planking is the structure of the hull. The term shell-first is more than applicable, since the first several strakes were built up from the keel prior to the addition of stem and sternposts. Furthermore, the planking actually served as the primary structure of the boat. From the "Hull Construction," we know that the hull was constructed in a carvel manner with dowel tenons maintaining alignment of the strakes. It is also known that these tenons were not pegged as in mortise-and-tenon construction, used in the early western boat building tradition; instead, sewing kept the planks from separating. The manner in which these planks were sewn together suggests that flexibility was part of the design. The sewing process was integrated with the caulking procedure. The thick caulking that overlaid the planking seam served not only to caulk the hull and reduce the sharp angle of stitching; its bulbous and compressible nature also provided a "shock absorber" for the stitching which passed over it. This caulking absorbed a portion of the force exerted on the stitching when the hull distorted. The movement of the planking (the hull itself) can be seen in the scarfing pattern of the strakes. All scarfs are simple non-locking diagonal junctures, which

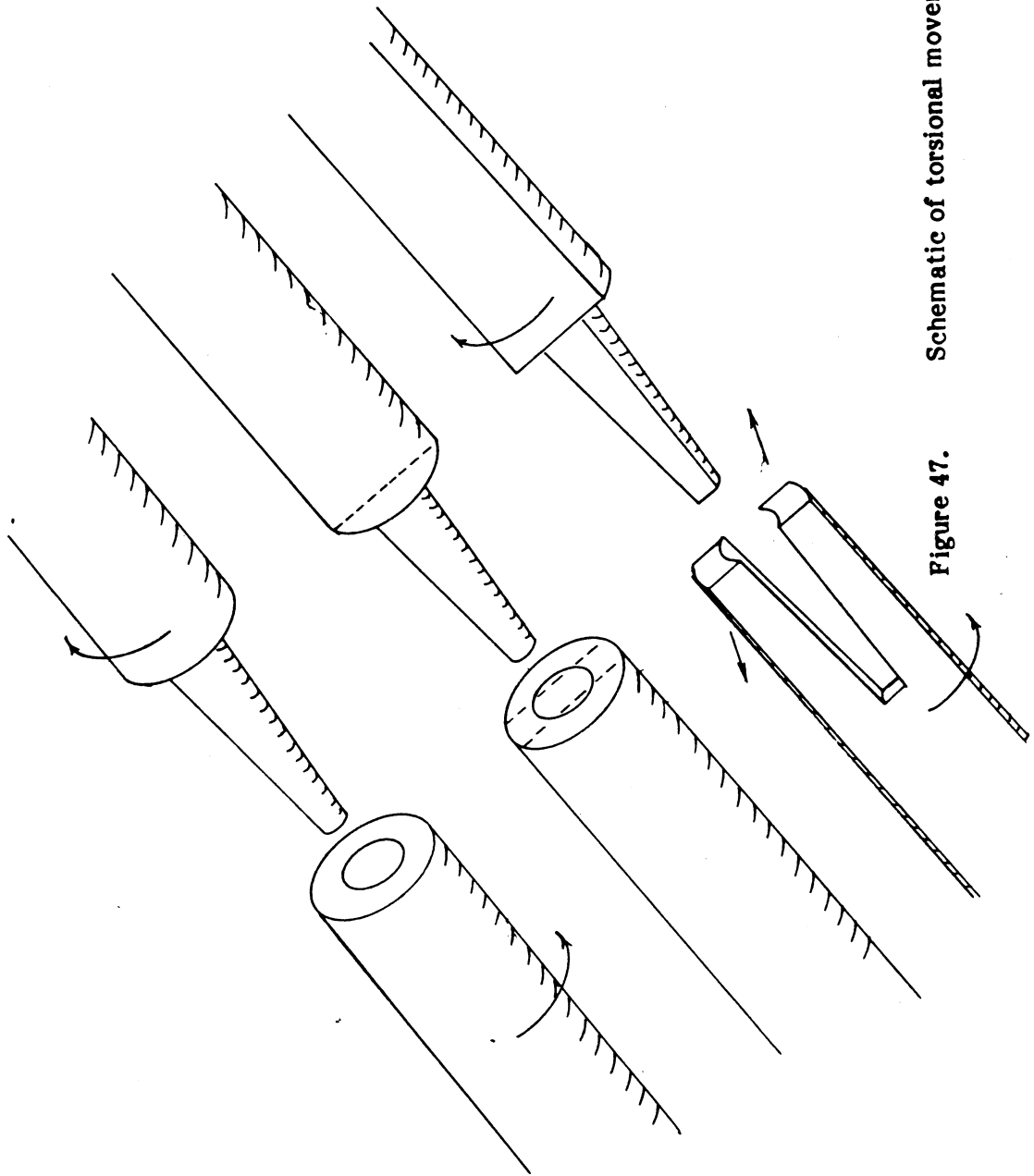

Figure 47. Schematic of torsional movement of stem post.

admitted movement of the hull. These scarfs and the manner in which the hull was sewn and caulked gave the hull its "great strength and flexibility" (Bowen, 1913:204).

The next component to be analyzed is the matched thwarts. They had several functions. The primary and most obvious was to delineate the width of the hull. The placement of the nether thwart at the waterline and the fact that the upper thwart was lashed directly over it are significant. This sandwiching of the upper thwart between the thwarts presents the bulwarks as a unit. It is this portion of the hull above the waterline which played a vital role in the hull competency. This pattern of matched thwarts is of great antiquity, as seen in early Egyptian depictions (Faulkner, 1941). Its structural function can be attested to by multiple levels of thwarts in the obelisk barge of Queen Hatshepsut (Bass, 1972:21). Their role in the competency of the hull will be explained momentarily when the physics of the hull is discussed.

Before discussing the physics of the hull, three internal components which complete the hull must be analyzed. They are the frames, stringers and partial decks, fore and aft.

The frames, which were lightly fastened to the hull and had no attachment between floors and futtocks, had a simple function. They provided a surface for the planking to rest or move against. Because floors and futtocks were not fastened to each other and were so sparsely fastened to the hull, they provided only a slight stiffening for the hull. Most importantly the sparse fastening allowed the hull to flex. The framing acted more as battens to maintain plank alignment and provide a platform for distribution of cargo weight, than as the true skeletal strength of the hull. The framing served secondarily to maintain the athwart ship-steps of the hull.

The stringers were the second internal component of the hull. These lightly fastened components were responsible for inhibiting the longitudinal flex, and probably to some degree the torsional flex, of the hull.

The partial decks at the forward and after ends of the hull joined the first and last two thwarts. In so doing, they inhibited or limited the torsional flex of the hull and provided a work surface for operating the vessel.

Now that the individual components have been analyzed, it is necessary to examine their integration into a system: the hull. These components were designed to accommodate movement. This movement is termed flexibility.

In the western tradition, excessive flexibility in the hull of a vessel is considered a weakness. If we examine this hull not in terms of strength or weakness but in terms of competency, we become aware of one situation when the hull of the mtepe was in its least competent state. This was when the mtepe was beached and it was necessary to support it in an upright position to prevent damage to the hull. To accomplish this task, poles were lashed to the matched thwarts on the exterior of the hull as shown in Figures 12 (p. 27), 27 (p. 45) and 48.

This inherent weakness, properly termed incompetency, hints at the flexible nature of the hull design. It becomes apparent that the hull was constructed so that the water in some way added competency to it. We have previously seen that the planks were joined to each other by dowel tenons and by sewing. These fastenings were relatively weak out of the water. The primary purpose of these dowel tenons was to maintain the edge-to-edge alignment of the planks, with the structural competency of the hull coming from the applied buoyant force of the water. This compression of the hull by a buoyant force is analogous to the force of gravity that is exerted downward on a freestanding arch.

In order to describe the mtepe's structure as competent, it is necessary to determine that there was a force opposing that of the water. The force that opposes the gravitational force in the analogous arch is the centripetal force exerted by the rotation of the earth. In the sewn hull the opposing force would have been gravity. A closer look at several features of the mtepe shows that the portion of the hull that was above the waterline, and therefore not affected by buoyant force, was responsible for the opposing force. These features include the placement(s) of the nether thwart at or near the waterline, and the fact that the matched thwarts, which were lashed together to present the bulwarks as a single unit, opposed the portion of the hull below the waterline. (The principle of presenting the bulwarks as an opposing force is an ancient one; it may have been applied in construction of Queen Hatshepsut's obelisk barge.) Additionally, the mast was engineered so that its weight did not directly oppose the buoyant force by distributing the weight of the mast over the mast step. It also transferred a portion of its weight to the uppermost thwart and bulwarks by being canted forward.

So, when the sewn hull was in the water the bulwarks acted against the submerged portion to make it competent. In physical terms, the force of gravity opposed the buoyant force. The resulting compression was absorbed primarily by



Figure 48. "Dau la mtepe at low tide", Fort Jesus Museum, Mombasa, Kenya.

the caulking, giving the hull its competency. This principle of compression did not allow the frames to be securely pegged to each strake, as this would have interfered with the transfer of force from one strake to another.

Further evidence that this principle was integral in the organization of the mtepe's hull is Pearce's statement that the vessel was unable to carry a cargo of coconuts (Pearce, 1920:30). When this curious comment is examined in the context of the principle of buoyancy/compression, it is apparent that cargo density was of the utmost consideration. If the cargo had nearly the same density as the sea water, which provided the buoyant force and resultant hull competency, then the internal force per unit area would have been nearly the same as the external force, and the competency of the hull would have been greatly reduced. Since the frame spacing on the mtepe was wider than the average coconut, the coconuts would have rested directly on the planking. With such a small differential force, the hull would have been literally held together by threads.

Obviously, the hull was designed at every juncture to be flexible, and its competency was directly related to the compression force exerted on it by the water.

The sewn hull can no longer be regarded as a "wretched affair" (Yules, 1875:111), but rather as a well-designed hull using flexibility as the basic principle in its design. The mtepe was inexpensive, quickly constructed, and versatile. Also, it was probably faster and therefore more efficient than those vessels constructed with rigid hulls.

PENTHOUSE CONSTRUCTION

A feature of most current day ships, as well as of ships of antiquity, is the deckhouse or cabin. This structure provides shelter for various persons and articles. The mtepe followed in this tradition with a simple shelter covering the waist of the boat aft of amidships, and forward of the after partial deck. Although this shelter was little more than a hip roof, it has been termed "penthouse" in the academic literature.

It is evident from the construction of the penthouse that it was structurally independent of the hull. Furthermore, it may be inferred that this shelter was built after completion of the hull and was probably not constructed by the boatwright. The practice of independent construction of deck cabins, or shelters, is well-established and appears to be nearly universal in its application.

The penthouse was of the simplest form: a hip roof supported by two uprights and two side walls that followed the curvature of the hull. The upright poles, which formed the base of the shelter, were lashed perpendicularly to matched thwarts. The after upright was lashed to the matched thwarts that served as the forwardmost terminus of the after deck. The forwardmost upright was positioned on the after side of the amidship thwarts. Joining the two uprights was a ridgepole. Poles serving as rafters connected the ridgepole to the sides of the hull, where they were lashed to the railing stanchions at the edge of the hull. These railing stanchions were poles that served as sidewalls. They were lashed to the sides of the frames and extended from near the bilge to well above the top strake. The portions of the poles that extended above the uppermost strake served as stanchions to which the railings were lashed. These railings and the stanchions to which they were lashed can be clearly seen on most of the photographs and models. After the rafters were lashed in place, they were covered with poles laid perpendicular to the rafters that served as decking. With the decking in place the structure of the penthouse was complete. A final detail was to cover the decking with dom palm fiber (see Fig. 42 oversize illustration at end of text).

The palm fiber covering on all models (Figs. 5 and 6 (pp. 17-18), 8 (p. 21), 9 (p. 22), 10 (p. 24), 13 (p. 28), and 15 (p. 30)) was woven in the same manner as the sail. Examination of archival photographs (Figs. 4 (p. 14), 11 (p. 25), 27 (p. 45) and 48 (p. 76)) showed that the covering for the roof was unwoven thatch. To further

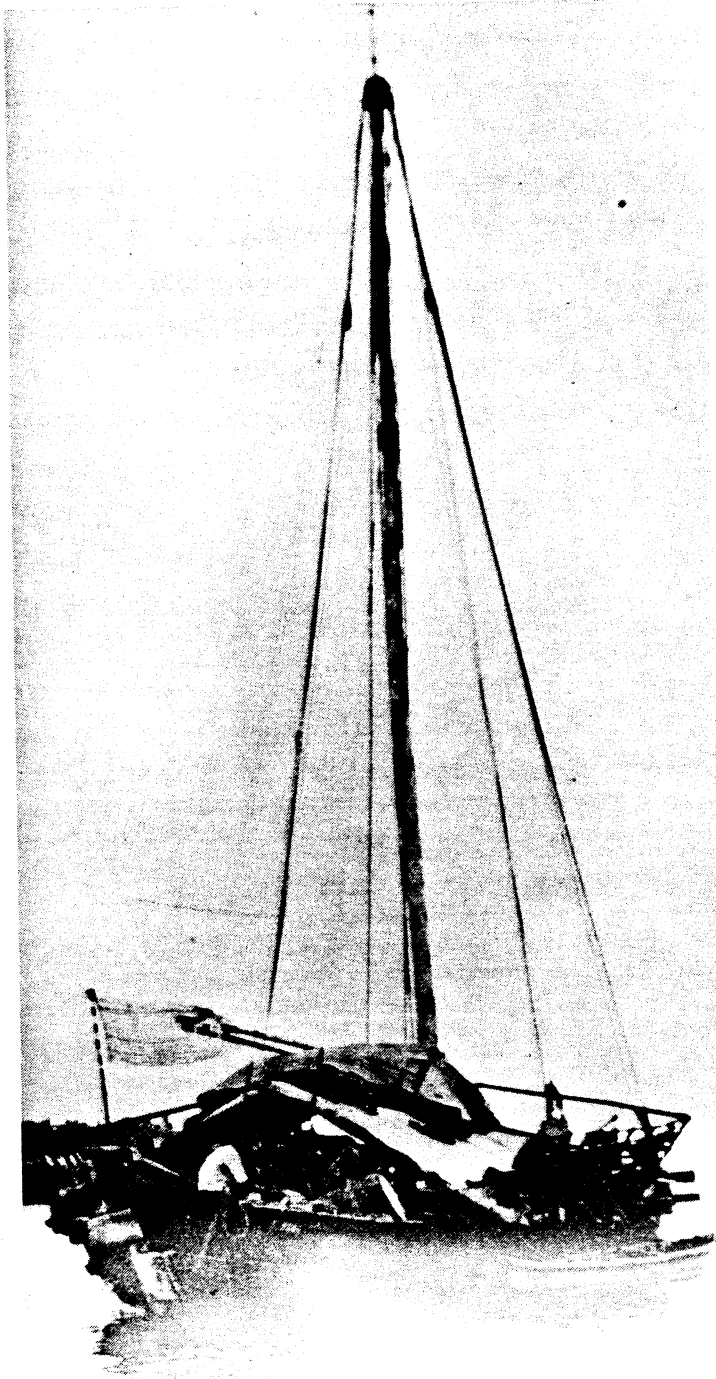

Figure 49.

"Dau la Mtepe at anchor in Old Mombasa Harbour", from John Jewell,
Dhows at Mombasa, p. 76.

confuse the matter, in (Figures 44 (p. 66), 28 (p. 46) and 49 unwoven thatch can be seen protruding from underneath the woven mat covering the penthouse. Figure 11 (p. 25) appears to show a combination of woven and unwoven thatch, and bare roof. Multiple explanations can be offered for the various roof coverings. Although the literature does not explain the differences, several possibilities could be presented; however, without references, they remain conjecture. As the roofing of the penthouse is a minor detail, independent of the structure of the boat, an explanation will not be offered.

This section on construction of the penthouse has been included to account for its presence, as it is a feature of the boat; although it is concluded that the penthouse is an independent, non-structural feature serving primarily to provide shelter for the crew.

CONSTRUCTION AND ANALYSIS OF THE RUDDER ASSEMBLY

The highly decorated stern rudder of the mtepe was secured to the sternpost by three or four coir fiber grommets and actuated with a tiller. Several other lines were also present, as well as a tassel that hung from the after end of the rudder. The rudder's multicolored, incised geometric design, along with the unwoven palm fiber tassel or "camel's tail" (according to legend), masked the engineering functions of the rudder components (Fig. 50).

The rudder of the mtepe initially appeared to differ primarily from that of its descendant the dau la mtepe in that the former was elaborately decorated and the latter was not. Close examination revealed that the clamp that held the tassel on the mtepe had been eliminated on the dau la mtepe. On the dau la mtepe, this clamp was replaced by notches cut into the trailing edge of the rudder blade to facilitate attachment of the tassel (Fig. 51).

During examinations of the photographs, I also noticed that the utilitarian rudder of the dau la mtepe still sported the tassel. This raised the question, Why did the tassel remain when other decoration had been eliminated from the rudder?

There are two possible explanations. One is that the tassel was of particular legendary or religious significance. The other is that it had a functional purpose. The latter of these is correct. But before a full explanation of the function of this tassel can be presented, a brief account of the technological evolution of the Indian Ocean rudder is necessary.

The rudders of the smallest sewn boats were attached to their angled sternposts by simple coir fiber grommets. A small hole was made in the sternpost and a corresponding hole in the rudder blade. Coir fiber grommets were lashed through these holes. These grommets supported the weight of the rudder and maintained its rotational axis. An example of a rudder hung in this fashion can be seen on the smaller sewn boats of the Somalia coast (Figure 52).

Various methods were used to actuate these rudders. The simplest was the attachment of lines from the trailing edge of the rudder so that it could be actuated from either side of the boat, in the same way as a push cart is steered by varying tension on the lines that run to the front axle of the cart. This design underwent modifications, which included various extensions and spreaders to gain more mechanical advantage over the action of the rudder. One of these

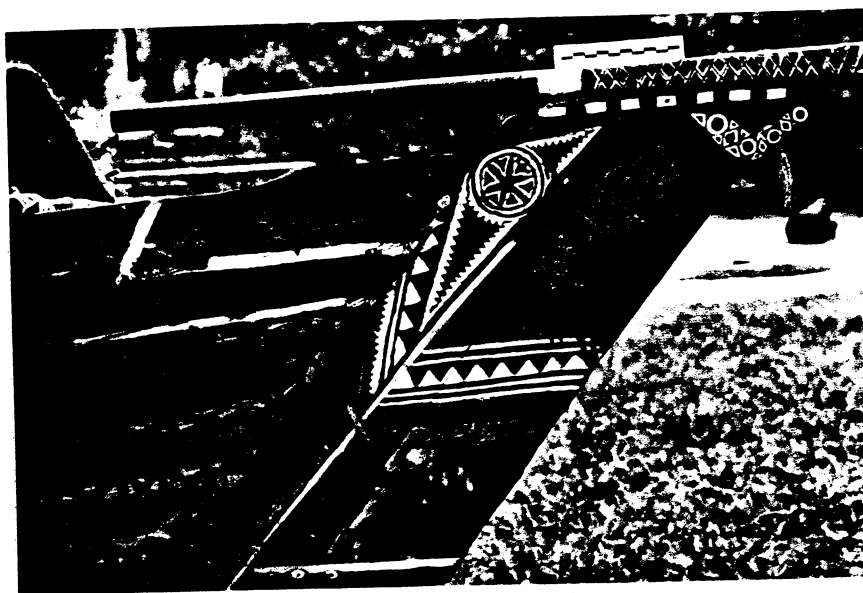

Figure 50. Rudder on mtepe model.

"Bajun Mtepe - made for Sir Mbarak bin ali Hinawi", Fort Jesus Museum, Mombasa, Kenya.

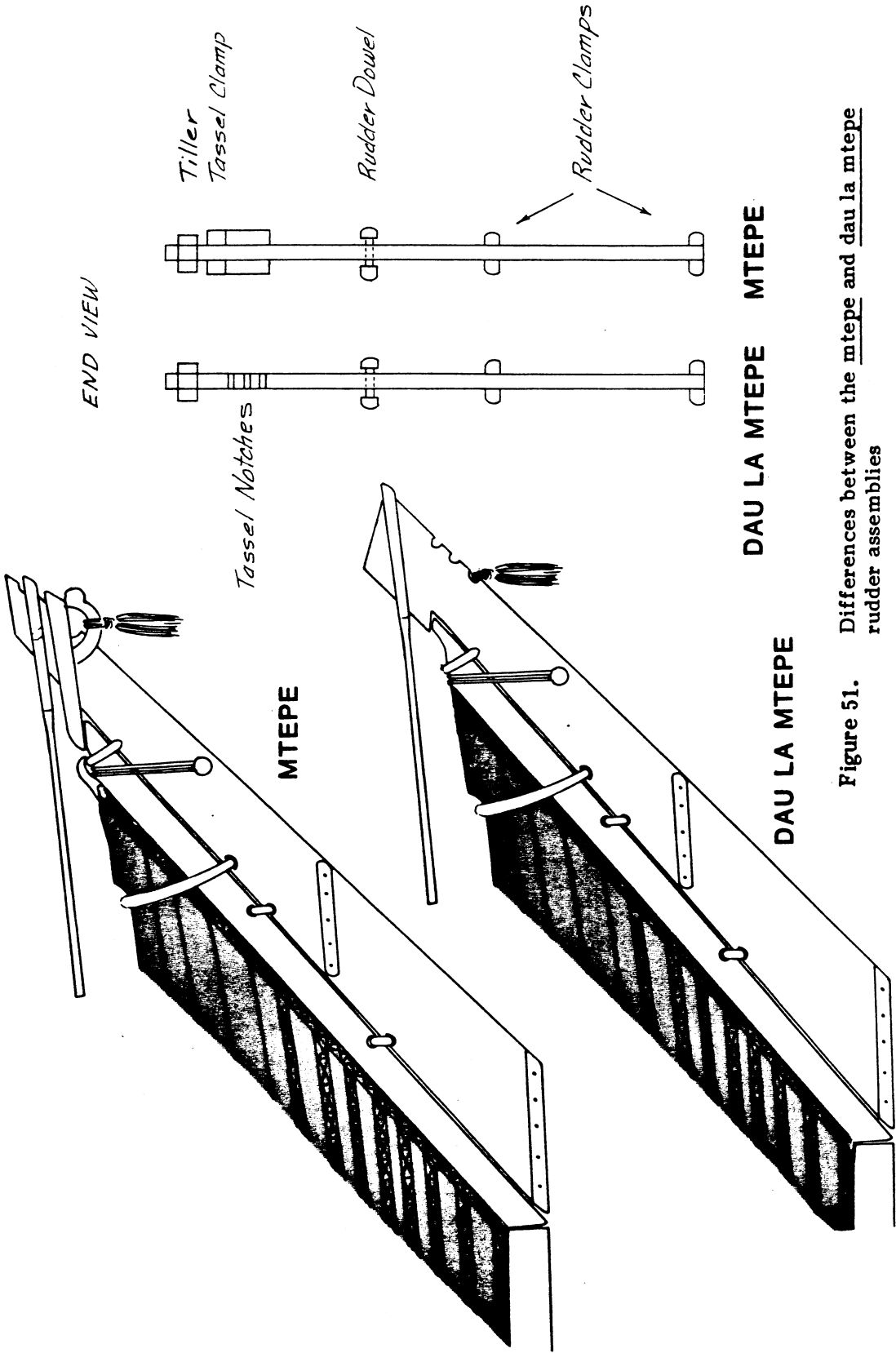

Figure 51. Differences between the mtepe and dau la mtepe rudder assemblies

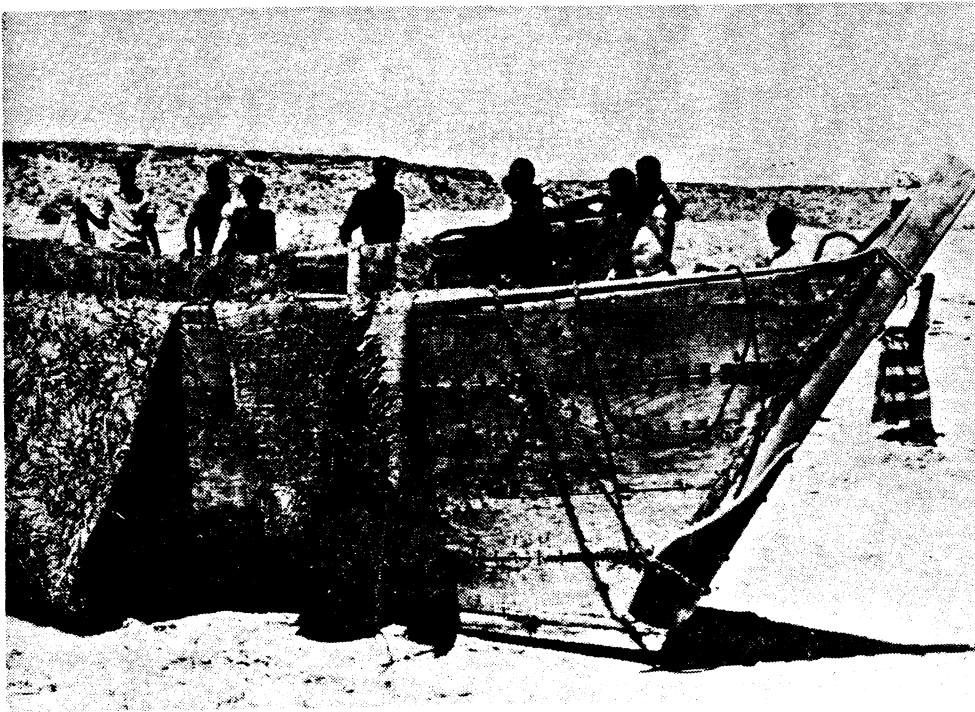

Figure 52.

Small rudder hung with simple coir fiber grommets, from Chittick,
LJNA 9, p. 301.

modifications was the addition of an extension aft of the trailing edge of the rudder, essentially an outboard tiller, actuated by lines. A variation of this method was to extend the rudder blade above the top of the sternpost and to remove the extension trailing aft, and place it at the top of the rudder facing inboard. This eliminated the need for lines and created the tiller as we know it today. This last style of rudder actuation was used on the mtepe.

Once the basic rudder and method of actuation are understood, other features of the rudder can be examined. The fastening of the rudder by simple coir fiber grommets was sufficient until the size of the vessel and consequently the size and weight of the rudder could not be easily managed when supported by these lashings. A rudder of this size was made from three or four pieces of wood joined to form the blade. Clamps were added at the foot, midway, and at the top of the blade to strengthen the composite rudder blade. The uppermost clamp was placed near the top of the rudder and was extended forward of the blade to rest just above the top of the sternpost. This uppermost clamp served several functions: 1) to strengthen the rudder blade, 2) to transfer the weight of the rudder to the sternpost while the vessel was beached, and 3) in the event that the line that held the weight of the rudder ever broke, to support the rudder. To accommodate this latter condition, the top of the sternpost was slightly domed to reduce the frictional area and to allow the clamp to move across the sternpost more easily.

As the size of the boats and consequently the size of their rudders increased, the difficulty of refitting a rudder at sea became greater. So, a rudder keeper became necessary. An example of a line used for this purpose is the lowermost line in Figure 53.

The tassel of unwoven palm fiber that hangs from the mtepe rudder has previously been characterized as a votive feature representing a camel's tail. If the tassel was merely a decorative ornament, it is difficult to explain its presence, in some form, on all examples of the later dau la mtepe, which had no other votive decorations. If we reason that this was a decorative motif of great importance, once again we find a difficulty. Figures 44 (p. 66), 28 (p. 46) and 50 (p. 82) show a dau la mtepe without the traditional "camel's tail". A common woven bag with some unknown contents had taken its place. Hence, the statement that the tassel is votive should be challenged. Further scrutiny of the dau la mtepe rudder shows that the rudder had been simplified in several ways; the uppermost clamp that transferred the weight of the rudder to the sternpost while the vessel was beached



Figure 53. Rudder and aft portion of dau la mtepe" - photo by R. C. Gilfillian Esq., Fort Jesus Museum, Mombasa, Kenya (rudder assembly)

had been eliminated and a notch had been set into the rudder blade to serve the same purpose. In addition, the clamp that served to hold the tassel on the mtepe proper had been eliminated and the tassel was hung from the after edge of the rudder blade, where three notches were present to hold it. It is clear that the tassel had some functional purpose.

Before the tassel's function can be better explained, one more component of the rudder assembly must be defined and analyzed.

When the rudder reached larger proportions, its weight, when hung on an angled sternpost, made movement from side to side very difficult. To correct this difficulty a line was used to support the weight of the rudder from a single point. This load-bearing line was looped around a dowel that had been inserted through the rudder blade and projected a few inches on both sides of the blade. The line was slung from this dowel up and over the top of the sternpost in a vertical orientation and then down to the other side of the rudder blade, where it was attached to the other side of the dowel. This dowel had a knob on both sides that kept this line from slipping off during use. The line served to remove the weight on the grommets and allowed the rudder to move freely. Placement of this line that supported the weight of the rudder was important. Ideally the line should have been suspended from the center of mass of the rudder (Fig. 54), a position where all forces were balanced and there would have been no weight exerted on the rudder grommets, and where the rudder blade would not have rotated about this axis.

Determining whether the line was attached at the exact center of mass involves making several judgments. These concern whether the rudder was balanced with or without the tiller; the exact dimensions (i.e., mass) of tiller, rudder blade and tassel; and whether the calculation was based on the rudder being out of water, partially immersed or immersed under full burden. Many of these facts are available but a few critical criteria are missing, making a geometrically or mathematically quantifiable answer impossible. As a result, two qualitative possibilities present themselves: 1) that the line was attached to the center of mass; or 2) that the line was not attached at the center of mass due to the necessity of placing the line over the sternpost.

In an attempt to determine the point of attachment, the function of the rudder tassel must be considered. The tassel had two characteristics: 1) it was mounted aft of the point of attachment of the load-bearing line (i.e., at the center or approximate center of mass), 2) it was located above the water.

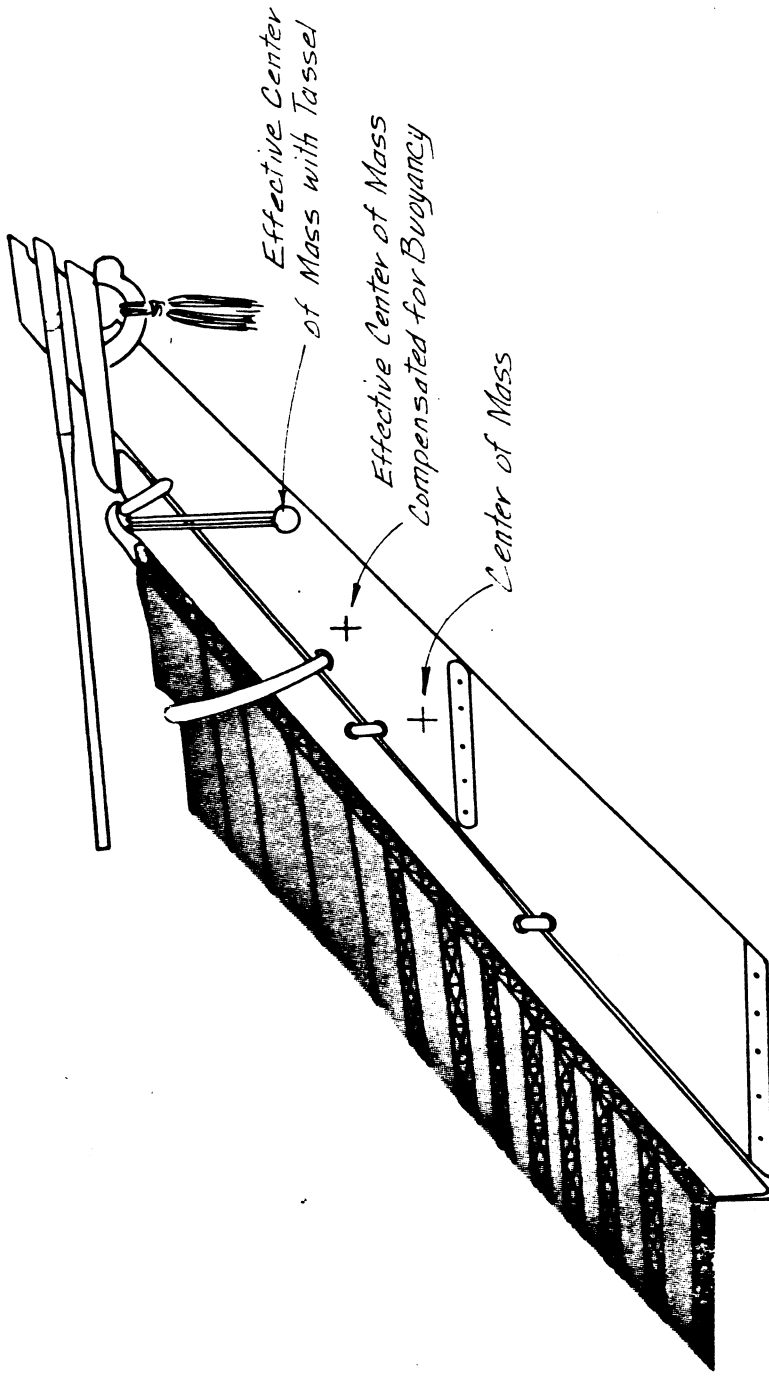

Figure 54. Rudder assembly showing location of effective center of mass when tassel is added.

The tassel, which in some cases had been replaced by a bag of unknown contents, may have functioned as a weight or counterbalance. Proceeding with this premise, it is necessary to integrate the placement of the rudder load bearing line and the function of the rudder tassel.

If the load bearing line had been attached at the center of mass of the rudder, the tassel could have served two functions. If the center of mass (i.e., balance point) were calculated with the tassel attached, it would have been located somewhere below the waterline on the rudder. It is probable that the rudder's center of mass would have been calculated for its normal position under sailing conditions, and compensated for the buoyant force caused by the displacement of the rudder. This buoyant force opposing the weight of the rudder would have raised its center of mass to a new location, which will be termed effective center of mass. With these calculations for the mass of the rudder and tassel complete, the rudder would have been well-balanced, with no excessive strain on any of the grommets holding the rudder to the sternpost, although a brief examination of the archival photographs shows that the mtepe, when fully laden, had nearly 60% of its rudder submerged. A problem becomes apparent--if enough of the rudder blade was submerged, the buoyancy would have caused it to float. The tassel may have acted as additional weight above the waterline to keep the buoyant force in equilibrium. The balance of forces within the system would have been maintained.

The second function that the tassel may have fulfilled was as a counterweight to balance the tiller. If the rudder blade was already well-balanced, the addition of an unbalanced tiller would have adversely affected the system. The moment arm about which the tiller was balanced was the point where the load-bearing line was attached. Although the angle in Figure 28 (p. 46) is obscure, it appears that the rudder may have been balanced about this point. But it can be clearly seen in Figure 24 (p. 43) that its tiller was not balanced about this point.

The third, and most likely, function of the rudder tassel was related to the placement of the load-bearing line. It has been shown that the rudder was designed to be hung from a point which had been determined as its effective center of mass. The rudder could have been hung from this point in two ways. The first would have been to hang it directly on a line, as previously discussed. The second would have been to hang the rudder at nearly the center of mass and change the mass to fit the point. Use of this second method is evident in the mtepe rudder. When the effective center of mass was estimated, it would have been suspended from a line a

short distance forward of the after end of the vessel. A line in this position on the vessel would have caused several difficulties in the vessel's operation. The most suitable place to locate the load-bearing line would have been over the sternpost but this would have left the effective center of mass forward of the line. The solution would have been to add mass to the rudder behind the point where it was suspended to bring the effective center of mass aft. The most effective position to place this weight would have been as far aft as possible to maximize its moment arm: the position of the rudder tassel.

Whether the purpose of the tassel was to compensate for the buoyancy of the rudder blade, counterbalance the tiller, or more probably, to move the effective center of mass, cannot be determined conclusively until further information becomes available.

However, from sources now available, it is apparent that the rudder assembly was a well-designed, well-balanced system.

CONCLUSION

Little literary or archaeological information is available from which to study sewn boats of antiquity. The only sewn boat that could be defined accurately was the mtepe, a relic sewn boat of the Western Indian Ocean. The antiquity of its design is left to conjecture as its history can be definitely traced to only about the sixteenth century A.D. (Prins, 1959:211), although several previous authors have strongly expressed conviction that the mtepe, or its counterparts, were the same as the sewn boats mentioned in Periplus of the Erythraean Sea (Stuhlmann, 1910:82; Pearce, 1920:28; Ingram, 1931:304). Similarities in trade areas, materials used in construction, and the level of refinement in design make this a viable conclusion. But, as there are few examples and little information for comparison, the antiquity of the mtepe's design must remain undetermined.

The antiquity of the sewn boat, or that of the mtepe, is secondary to the implication that these vessels were well designed. The mast assembly was designed to be independent of the hull but contributory to hull competence. The sail and associated rigging of the mtepe approach the limits of efficiency in their design. The penthouse was constructed after the completion of the hull and was designed to shelter the crew, not to deal with the forces of the sea. Additionally, the rudder was well-engineered, and the forces exerted on it were balanced. The rudder tassel which had been previously considered as decoration was actually an integral part of the system. This is significant in view of the tendency of authors to classify those features that are unexplained as decorations or "spiritual equipment" (Field, 1925:524). These authors may have also regarded these vessels as "wretched affairs" (Yules, 1875:111), as did Marco Polo.

Lastly, this thesis has shown that the sewn hull was designed to be flexible. There may have been several reasons for the flexibility in its construction. The flexibility may have been the result of the craft's evolution from a non-competent vessel (that is, papyral, skin, or riverine craft); the lack of suitable materials (that is, wood, metal fasteners); or possibly a different approach than that of western boat building in dealing with the forces exerted on a vessel in the open ocean. Whatever the reason or combination of reasons, these vessels did have inherent flexibility that was probably the result of thousands of years of refinement. This refinement produced "a ship of singular grace and beauty, of great carrying

capacity, and of remarkably good sailing power" (Field, 1925:524). The efficiency of its design is attested to by its widespread use and longevity.

The conclusion that certain ancient vessels were designed with a flexible technology presents several possibilities for further postulation and research. These include the progression from flexible to rigid hulls, the evolution of edge fastening, and the role of the introduction of relatively high density containerized cargoes (that is, amphoras) in the development of rigid hulls. These questions and many more will continue to be the impetus for further speculation until an archaeological example or accurate replica provides additional information to help us further understand the sewn boats of antiquity.

REFERENCES

- Abubaker, A. M. and A. Y. Moustafa, 1971, The Funerary boat of Khufu. Beitrag zur agyptischen Bauforschung und Altertumskunde, 12. Weisbaden.
- Anderson, R. C., 1927, The Rigging of Ships in the Days of the Sprintsail Topmast 1600-1720. Marine Research Society, Salem.
- Ashburner, W., 1909, The Rhodian Sealaw. Oxford.
- Barbosa, D., 1918, A Description of the Coasts of East Africa and Malabar. London: printed for the Hakluyt Society, University of Utah.
- Bass, G. F., editor, 1972, A History of Seafaring Based on Underwater Archaeology. New York.
- Bennett, J. W., 1954, The Rediscovery of Sir John Mandeville. New York.
- Bennett, N. R., 1978, A History of the Arab State of Zanzibar. London.
- Bowen, R. L. Jr., 1949, Arab dhows of Eastern Arabia. American Neptune, 20:27-132.
- Bowen, R. L. Jr., 1952, Primitive watercraft of Arabia. American Neptune, 12:186-221.
- Bowen, R. L. Jr., 1957, Arab Anchors. Mariners Mirror 43:288-95.
- Brøgger, A. W., et al., 1951, The Viking Ships: Their ancestry and evolution. Oslo.
- Burckhardt, J., 1829, Travels in Arabia. 2 volumes. London.
- Burton, Sir R. F., 1856, First Footsteps in East Africa. London.
- Burton, Sir R. F., 1872, Zanzibar; City, Island and Coast, 2 volumes. London.
- Burton, Sir R. F., 1893, Personal Narrative of a Pilgrimage to Al-Madinah and Meccah, 2 volumes. New York.
- Chittick, N. H., 1967, Discoveries in the Lamu Archipelago. Azania 2: 46 and 66.
- Chittick, N. H., 1970, Observations on pre-Portuguese accounts of the East African coast. Sociétés et Compagnies de Commerce en Orient et dans l'Océan Indien, ed., M. Mollat. Paris.
- Chittick, N. H., 1978, Sewn boats in the Western Indian Ocean and a survival in Somalia. Int. Conf. of Ind. Ocean Studies, Section III, British Institute in East Africa, Nairobi: 1-6.
- Chittick, N. H., 1980, Sewn boats in western Indian Ocean and a survival in Somalia. IJNA, 9:297-309.

- Chittick, N. H. and R. I. Rotbert, 1975, East Africa and the Orient, Cultural Syntheses in Pre-Colonial Times. New York and London.
- Clive, J., 1933, The Mtepi. Lamu Political Records, II, Aug. 19. Kenya National Archives DC/LAM/3/2.
- Datoo, B. A., 1970, Misconceptions about the use of monsoons by dhows in East African waters. East African Geography, Rev. 8:1-10.
- Dickinson, H. R. P., 1949, The Arab of the Desert. London.
- Dunlop, D. M., 1971, Arab Civilization to 1500 A.D. London.
- Elliot, J. A. G., 1925, A visit to the Bajun Islands. Journal of the African Society, 25:11-23.
- Ettinghausen, R., 1977, Treasures of Asia Arab Painting, Washington, D.C.
- Fahmy, A. M., 1966a, Muslim Sea Power in the Eastern Mediterranean from 7th to 10th Centuries A.D. 1st edition Cairo.
- Fahmy, A. M., 1966b, Muslim Naval Organization in the Eastern Mediterranean from 7th to 10th Century A.D. 2nd edition Cairo.
- Falconer, W., 1970, Falconer's Marine Dictionary (1780). David & Charles Reprints, Great Britain.
- Faulkner, R. O., 1941, Egyptian Seagoing Ships. Journal of Egyptian Archaeology 26:4.
- Field: The Country Gentlemens Newspaper, Thursday, September 24, 1925:524-525. London.
- Freeman-Grenville, G. S. P., 1965, The French at Kilwa Island: An Episode in Eighteenth Century East African History. Oxford.
- Gama, Vasco da, 1898, A Journal of the First Voyage of 1497-99, Hakluyt Society, work no. 99. London.
- Ghaidan, U., 1975, Lamu: A Study of the Swahili Town. Nairobi.
- Gibb, H. A. R., 1958, The Travels of Ibn Battuta A.D. 1325-1354. Cambridge.
- Gilfillan, S. C., 1935, Inventing the Ship. Chicago.
- Glanville, S. R. K., 1972, Catalog of Egyptian Antiquities in the British Museum II: Wooden Model Boats. Oxford.
- Goitein, S. D., 1973, Letters of Medieval Jewish Traders. Princeton.
- Gomes de Brito, B., 1959, The Tragic History of the Sea 1589-1629, edited from the original Portuguese by C. R. Boxer. Cambridge.

- Gove, P. B., editor, 1976, Third New International Dictionary of the English Language Unabridged. Springfield, Mass.
- Greenhill, B., 1971, Boats and Boatmen of Pakistan. Newton Abbot, U.K.
- Greenhill, B., 1976, Archaeology of the Boat. Middletown, Connecticut.
- Gregory, J. W., 1969, The Foundation of British East Africa. New York.
- Grottanelli, V. L., 1955, Pescatori dell'oceano Indiano. Rome.
- Guillain, M., 1848, Documents sur l'histoire, la geographie et le commerce de l'Afrique Orientale. Paris.
- Haddon, A. C., 1918, The outrigger canoe of East Africa. MAN 29:49-54.
- Hatchell, G. W., 1961, The Ngalwa and the Mtepe. Tanzania Notes and Records 57:211-215.
- Hitti, P. K., 1951, History of the Arabs from the earliest times to the present. New York.
- Hornell, J., 1926, Nomenclature of Eastern Sea Craft. Mariners Mirror 22:230.
- Hornell, J., 1941a, The sea-going mtepe and dau of the Lamu Archipelago. Mariners Mirror 27:54-68.
- Hornell, J., 1941b, Seatrade in Early Times. Antiquity 15:233-56.
- Hornell, J., 1942, The tentative classification of Arab sea-craft. Mariners Mirror, 28:11-40.
- Hornell, J., 1970, Water Transport: Origins and Early Evolution. Newton Abbot, U.K.
- Horwath, D., 1977, Dhows. London, Melbourne, N.Y.
- Hourani, G. F., 1963, Arab Seafaring. Beirut.
- Huntingford, G. W. B., 1980, The Periplus of the Erythraean Sea. London.
- Ingram, W. H., 1931, Zanzibar: Its History and Its People. London.
- International Conference of Indian Ocean Studies, 1979, Section III - The History of Commercial Exchange and Transport, Perth, W. Australia, August 15-22. Murdoch University, University of Western Australia and Western Australia Institute of Technology.
- James, B., 1964, Travels to Discover the Source of the Nile. New York.
- Jenkins, N., 1980, The Boat Beneath the Pyramid: King Cheops' Royal Ship. New York.

- Jewell, J., 1969, Dhows at Mombasa. Nairobi.
- Johnstone, P., 1974, The Archaeology of Ships. London, Sydney, Toronto.
- Jones, V., 1978, Sail the Indian Sea. London.
- Kirkman, J. S., 1954, The Arab City of Gedi: Excavations at the Great Mosque, Architecture and Finds. Oxford.
- Kirkman, J. S., 1970, The coast of Kenya as a factor in the trade and culture of the Indian Ocean. Societies et Compagnies de Commerce en Orient et dans l'Océan Indien, ed., Michael Mollat. Paris.
- Kirkman, J. S., 1974, Fort Jesus: A Portuguese Fortress on the East African Coast. Oxford.
- Krapf, J. L., 1858, Reisen in Ostafrika. 1964 reprint, Stuttgart.
- Krapf, J. L., 1865, Travels, Researches, Missionary Labours during an 18 Year Residence in East Africa. London.
- Landstrom, B., 1961, The Ship: an Illustrated History. Garden City, New York.
- Lane, F. C., 1934, Venetian Ships and Shipbuilders of the Renaissance. Baltimore.
- Lydekker, C. J. W., 1919, The mtepe dahau of the Bajun Islands. MAN 19 (June):88-92.
- Martin, E. B., 1978, Cargoes of the East: The Ports, Trade and Culture of the Arabian Seas and Western Indian Ocean. London.
- Mookerji, R., 1962, Indian Shipping: A History of Sea-borne Trade and Maritime Activity of the Indians from the Earliest Times. Calcutta, Bombay, Delhi.
- Moore, A., 1920a, Craft of the Red Sea and Gulf of Aden. Mariners Mirror 6:73-76.
- Moore, A., 1920b, Craft of Red Sea and Gulf of Aden. Mariners Mirror 6:136-162.
- Moore, A., 1942, Notes of dhows. Mariners Mirror 28:205-215.
- Moule, A. C. and P. Pelliot, 1938, Marco Polo - the Description of the World. 2 volumes. London.
- Muckelroy, D., editor, 1980, Archaeology under water: An Atlas of the World's Submerged Sites. New York, London.
- Muir, J., 1965, Early Arab Seafaring and Rudders. Mariners Mirror 51:357-359.
- Nabhany, A. S., 1977, Sambo ya Kiwandeo, The Ship of Lamu Island. Leiden, Holland.
- Nichols, C. S., 1971, The Swahili Coast: Politics, Diplomacy, and Trade on the East African Littoral, 1798-1856. New York.

- Oertling, T., 1979, Dowel Tenon Fasteners: A Distributional Survey, unpublished, ms., Texas A&M University.
- Owen, W. F. W., Capt., 1833, Narrative of Voyages to Explore the Shores of Africa, Arabia, and Madagascar L. London.
- Palgrave, W., G., 1865, Narrative of a Years Journey through Central and Eastern Arabia, 1862-1863. 2 volumes, London.
- Paris, E., 1841a, Souvenirs de Marine. Collection de plans ou dessins de navires et de bateaux anciens ou modernes, existants ou disparus, avec les elements numeriques necessaires a leur construction, par le vice-amiral Paris, Paris.
- Paris, E., 1841b, Essai sur la construction navale des Peuples extra-Europeens ou Collection des Navires et Pirogues construites par les habitants de l'Asie, de la Malaisie, du Grand Ocean et de l'Amerique, Paris.
- Parkinson, C. N., 1937, Trade in the Eastern Seas. Cambridge.
- Peabody, C. H., 1917, Naval Architecture. New York.
- Pearce, F. B., 1920, Zanzibar: The Island Metropolis of Eastern Africa. New York.
- Phillips-Birt, D., 1979, The Building of Boats. New York.
- Pitot, A. and J. Daget, 1948, Les Barques du Moyen Niger. Documents d'ethnographie navale, Fascicule 5. Paris.
- Poujade, J., 1946, Pirogues et ca-vom de l'Ouest Cochinchinois. Documents d'ethnographie navale, Fascicule 2. Paris.
- Poujade, J., 1948, La Machoua de Versova. Documents d'ethnographie navale, Fascicule 4. Paris.
- Prins, A. H. J., 1959, Uncertainties in Coastal Cultural History: The 'Ngalwa' and the 'Mtepe'. Tanzania Notes and Records 53:205-213.
- Prins, A. H. J., 1965, Sailing from Lamu, A Study of Maritime Culture in Islamic East Africa. Assen, Holland.
- Prior, J., 1819, Voyage Along the East Coast of Africa. London.
- Reed, Sir E. J., 1885, A Treatise on the Stability of Ships. London.
- Reisner, M. G. A., 1913, Catalogue General des Antiquites Egyptiennes du Musee du Caire. Nos. 4798-4796 et 5034-5200, Models of Ships and boats. Cairo.
- Rockhill, W. W., 1900, The Journey of William of Rubruck to the Eastern parts of the World, 1235-55. Hakluyt Society.
- Sassoon, C., 1970, The dhows of Dar es Salaam. Tanzania Notes and Records 71:185.

- Schoff, W. H., 1912, Periplus of the Erythraean Sea. New York.
- Serjeant, R. B., 1963, The Portuguese of the South Arabian Coast. Oxford.
- Severin, T., 1982, In the Wake of Sinbad. National Geographic, 162, no. 1:2-40.
- Seymour, M. C., 1968, Mandeville's Travels. London, New York, Toronto.
- Slane, D., 1978, The Origin and Diffusion of the Oculus, unpublished, ms., Texas A&M University.
- Smyth, H. W., 1906, Mast and Sail in Europe and Asia. London.
- Stigand, C. H., 1966, The Land of Zinj: Being an Account of British East Africa its Ancient History and Present Inhabitants. New York.
- Stuhlmann, F., 1910, Handwerk und Industrie im Ostafrika. Hamburg.
- Thomas, B., 1931, Alarms and Excursions in Arabia. London.
- Torr, C., 1895, Ancient Ships. Cambridge.
- Villiers, A., 1952a, The Indian Ocean. London.
- Villiers, A., 1952b, Monsoon Seas: The Story of the Indian Ocean. New York, London, Toronto.
- Villiers, A., 1961, Sailing with the Arabs. Mariners Mirror 47:242-55.
- Villiers, A., 1969, Sons of Sinbad. New York.
- Underhill, H. A., 1965, Masting and Rigging: The Clipper Ship and Ocean Carrier. Glasgow.
- Vallerin, G. G., 1978, Le Periple de la Mer Erythree. Dossiers de l'Archeologie 29.
- Waters, R. P., 1965, American Consul to Zanzibar. 18 October 1842 New England Merchants in Africa. Boston.
- Were, G. S., et al., 1968, East Africa Through a Thousand Years: A History of the Years A.D. 1000 to the Present Day. New York.
- Winkler, H. A., 1939, Rock Drawings of Southern Upper Egypt, Part 1. London.
- Winlock, H. E., 1955, Models of Daily Life in Ancient Egypt: From the tomb of Meket-re at Thebes. Cambridge, Massachusetts.
- Yules, S., 1875, Ser Marco Polo, 2nd edition, 1. London.

APPENDIX 1
Spellings of Mtepe

The following is a list of the various spellings used by authors when referring to the mtepe or the dau la mtepe. When not enough detail in the description has been made to clearly identify which vessel is being described the spelling has been placed between the two columns.

		<u>mtepe</u>	<u>dau la mtepe</u>
Chittick	1979 (I.C.I.O.S)	mtepe	dau la mtepe
Greenhill	1976	mtepe	mtepe
Prins	1959	mtepe	dau la mtepe
Grottanelli	1955	mitepe	
Hornell	1941	mtepe	dau
Ingram	1931	mitepe	dau ya mtepe
Pearce	1920	mtepe	
Lydekker	1919	mtepe	
Stuhlman	1910	mtepe	
Smyth	1906	matape	

VITA

ROBERT MARSHALL ADAMS

4906 West Park, Austin, Texas 78731

Education

- 1978- Texas A&M University, Department of Anthropology, Nautical Archaeology Specialization. Master of Arts.
- 1976-1978 University of Minnesota, Duluth. B.A.S. (cum laude). Earth Sciences, with teaching certification.
- 1975 Our World-Underwater Scholarship.
- 1972-1975 University of Minnesota, Minneapolis.

Archaeological Experience

- Yorktown Shipwreck Archaeological Project, Yorktown, Virginia.
- Espey, Huston & Associates, Inc. Engineering and Environmental Consultants, Austin TX.
- Institute of Nautical Archaeology (INA) - Pedro Bank Survey, Jamaica, B.W.I.
- 175 Water Street Project - Manhattan, N.Y.C.
- Texas A&M University, Department of Geography. Graduate Assistant Teaching in physical geography.
- Texas A&M University, Cultural Resources Laboratory. Freeport Ship Channel magnetic anomaly verification.
- INA Cayman Islands Project, Cayman Islands, B.W.I.
- Texas A&M University, Nautical Archaeology Program. Graduate Assistant Research (two semesters).
- INA Mombasa Wreck Excavation, Mombasa, Kenya.
- Thracia Pontica International Symposium, Sozopol, Bulgaria. United States observer.
- INA "Glass Wreck" Research, Bodrum, Turkey.
- INA Excavation at Serce Liman, Turkey.
- Survey of the Sidewheel Steamboat Black Cloud, NOAA Sea Grant Publication, 1979.
- American Institute for Exploration. Japanese-American Aleutian-Bering Sea Expedition, Dutch Harbor, Alaska. 1975.

Presentations

- Conference of Underwater Archaeology, "Yorktown Shipwreck Archaeological Project: 1984 excavation."
- Conference of Archaeology and Ethnography of Sewn Planked Boats, "Designed Flexibility in a Sewn Boat of the Western Indian Ocean", Greenwich, England.
- Conference of Underwater Archeology, "The stern projections of the Thera Frescoe boats: the transition from the steering oar to the stern rudder."