

THE WOODEN ANCHOR

A Thesis

by

DAVID DOUGLAS HALDANE

Submitted to the Graduate College of  
Texas A & M University  
in partial fulfillment of the requirements for the degree of  
MASTER OF ARTS

May 1984

Major Subject: Anthropology

THE WOODEN ANCHOR

A Thesis

by

David Douglas Haldane

Approved as to style and content by:

Frederick H. van Doorninck Jr.  
Frederick H. van Doorninck Jr.  
(Co-Chairman of Committee)

George F. Bass  
George F. Bass  
(Co-Chairman of Committee)

Zoltan J. Kosztołnyik  
Zoltan J. Kosztołnyik  
(Member)

J. Richard Steffen  
J. Richard Steffen  
(Member)

Vaughn M. Bryant  
Vaughn M. Bryant  
(Head of Department)

May 1984

ABSTRACT

The Wooden Anchor (May 1984)

David Douglas Haldane B.A. Hampshire College

Co-Chairmen of Advisory Committee:

Dr. Frederick van Doorninck Jr.

Dr. George F. Bass

The wooden anchor, apparently developed toward the end of the seventh century B.C., employed several non-wooden parts during its history: a stone or lead stock, bronze or iron fluke points and a lead collar at the arm/shank junction. When an anchor was lost on the seabed, its wood disintegrated, leaving only the non-wooden parts to mark its passing. Discovery of wooden anchor elements and, only infrequently, wooden anchors themselves, along with ancient literary works and depictions, has yielded an abundance of information and insights on this integral part of ancient seafaring. However, an overall view of ancient anchor development remains obscure, as this information has not been adequately analysed and synthesized.

Presently, a particularly valuable contribution to the study of ancient anchors is not the generation of new information, but an analysis and synthesis of existing information. By eliminating elements of redundancy and confusion I have provided an organized framework for further investigation.

**DEDICATION**

**To Robert and Elise**

## ACKNOWLEDGMENTS

To all of the helpful museum staff and curators along the European Mediterranean seaboard who assisted me with my research; particularly to the staff of the Museo Arqueologico and Museo Marittimo in Barcelona, Museo Bicknell in Bordighera, Bojidar Dimitrov of Sofia, and Christina Angelova of Sozopol;

To InterLibrary Services at Texas A & M University;

To M. Elise Haldane, Bettina Reineke, Stanislav Primozic and Aleydis van de Moortel for their patient efforts in translating;

To Karen Taylor for further typing assistance;

To the members of my advisory committee: Zoltan Kosztolnyik, J. Richard Steffy and George F. Bass, who knew when to ask questions and make suggestions, and when to leave me to my own devices; particularly to Frederick H. van Doorninck Jr. for his invaluable assistance and guidance;

To my wife Cheryl Anne Haldane, for her editorial, linguistic, logistic, typographic and, above all, moral support;

To Robert and Elise Haldane, who helped me make this possible...

Thank You.

## TABLE OF CONTENTS

	Page
ABSTRACT.....	iii
DEDICATION.....	iv
ACKNOWLEDGMENTS.....	v
TABLE OF CONTENTS.....	vi
LIST OF ILLUSTRATIONS.....	vii
LIST OF FIGURES.....	ix
LIST OF TABLES.....	x
LIST OF ABBREVIATIONS.....	xi
INTRODUCTION.....	1
DATING.....	5
RECONSTRUCTION.....	14
USE.....	32
CONCLUSION.....	35
PLATES.....	37
NOTES.....	39
REFERENCES CITED.....	65
APPENDIX 1.....	97
APPENDIX 2.....	104
APPENDIX 3.....	105
VITA.....	110

## LIST OF ILLUSTRATIONS

Illustration	Page
1. Types of wooden-anchor stocks with 1) shank, 2) fluke point or "tooth", 3) arm, 4) reinforcement collar, and 5) crown.....	4
2. Lead sources in the ancient Mediterranean: 220 B.C.....	11
3. Roman expansion in the ancient world: 192 B.C.....	11
4. Roman consolidation of lead sources in Spain, Sardinia, Italy and Greece: 145 B.C.	12
5. Chronology of wooden-anchor stocks.....	13
6. Stone-stocked, wooden anchor from Appollonia Pontica coin dated 350 B.C.....	14
7. Reconstruction of a type III-stocked anchor	15
8. Illustration of type III-stocked anchor with a bipartite shank.....	15
9. Kapitän's reconstruction of the stone-stocked wooden anchor.....	16
10. The wooden anchor from Lake Nemi.....	17
11. The iron anchor from Nemi.....	18
12. The wooden anchor remains from Chretiënne C.....	19
13. Bronze "tooth" from Porticello.....	20
14. Schematic cross section of reinforcement collars: A) top view, B) side view with angular arm/shank junction, C) side view with rounded arm/shank junction, D) one-armed anchor reinforcement collar from Brindisi.....	21
15. Anchor remains with head reinforcement collar from Isola Lunga.....	23

16.	Type IVA head reinforcement collar.....	24
17.	Lead core of a wooden stock from Porticello	25
18.	Type IIA stock cores from Cape Graziano....	26
19.	Creation of a type IIB-stocked anchor.....	26
20.	Cross section of a Type III anchor-stock mold.....	27
21.	Hawser ring from Porticello.....	29
22.	Cross section of a wooden anchor and mold prior to pouring.....	30
23.	Mold for a removable stock.....	31
24.	Drawing of a type III anchor stock with locations of measurements discussed.....	98

## LIST OF FIGURES

FIGURE		Page
1.	The Elba anchor.....	37
2.	Physical evidence discernible on the Elba anchor.....	37
3.	Anchors and <u>artemon</u> appearing on the Arc d'Triomphe at Orange .....	38

## LIST OF TABLES

Table	Page
1. Wooden-anchor stock typology.....	3
2. Equations used in computing anchor stock correlations with results expressed as a percentage of 100.....	99
3. Published type III anchor stocks and their measurements.....	100

## LIST OF ABBREVIATIONS

AA	Archäologischer Anzeiger
AJA	American Journal of Archaeology
AntJ	Antiquaries' Journal
ArchEspArq	Archivo Español de Arqueologia
BCH	Bulletin de correspondance hellénique
BdA	Bolletino d'Arte
BonnJbb	Bonner Jahrbücher
BSA	British School at Athens, Annual
BSAS	Bulletin de la Societe Archéologique, Scientific et Litteraire de Beziers
CAS	Cahiers d'Archeologie Subaquatique
CIA	Corpus Inscriptionum Atticarum
CRAI	Comptes rendus de l'Académie des inscriptions et belles lettres
Greek Papyri	Greek Papyri in the British Museum
IG	Inscriptiones Graecae
IJNA	International Journal of Nautical Archaeology and Underwater Exploration
ILN	Illustrated London News
JIAN	Journal international d'archéologie numismatique
JRS	Journal of Roman Studies
MAAR	Memoirs of the American Academy in Rome
MM	Mariner's Mirror
MS	Mondo Sommerso
MZ	Mainzer Zeitschrift

PEFQ	Palestine Exploration Fund Quarterly Statement
RA	Revue archéologique
RStLig	Rivista di Studi Liguri

## INTRODUCTION

Attempts to reconstruct ancient wooden anchors from extant remains were first made in the 1890s and 1920s.<sup>1</sup> With almost no evidence to guide them, scholars envisioned the lead anchor stock as the arms, or one of a pair of arms, of an anchor. Lack of evidence also led to misinterpretations of ancient texts.<sup>2</sup>

The reconstruction enigma was resolved in the 1930s when an intact wooden anchor with a lead stock was found in connection with two imperial Roman barges at Lake Nemi in Italy. The basic form of the ancient wooden anchor was revealed.<sup>3</sup>

The sufficiency of this revelation was short-lived, however, as three additional anchor stock forms came to light: the stone stock, the lead-filled wooden stock and the removable lead stock. More misguided reconstructions followed these finds: stone stocks were thought to be the arms of a grapnel anchor,<sup>4</sup> and lead cores of wooden stocks were seen as tenons for holding the anchor's arms to the shank.<sup>5</sup>

More rational conclusions developed as the determination of lead stock pouring techniques and formulations of early anchor constructions were made.<sup>6</sup>

---

This thesis follows the style of the American Journal of Archaeology.

However, no truly comprehensive study of the physical remains of anchors has thus far been undertaken.

Similarly, attempts to date anchor types by contextual or epigraphic means have tended more often toward broad as opposed to narrow chronological parameters.<sup>7</sup> Although two types of anchor stocks have received particular scholarly attention, dating attempts have been based more on stylistic than scientific evidence. Since no comprehensive typology was created, advances in dating furthered knowledge of one type of anchor stock and neglected others, leaving a spotty and rough understanding of the use of one anchor stock type in relation to the others.

Further, the question of shipboard use of anchors has been scarcely addressed. Forsaking most ancient literary references, modern authors have attempted to apply modern anchor requirements to ancient ships. Hypotheses on the use of ground tackle were superficially qualified with archaeological and literary evidence, if at all. An extensive study of ancient literary reference combined with extant archaeological evidence has yet to be made.

Towards a clearer understanding of the varieties of wooden-anchor stock types, a typology (table 1 and ill. 1) has been created by the author. This typology, chronological only in a general way, is fundamentally organized from simplest to most complex. Available evidence shows that some sub-types predate their

"predecessors" in this typological scheme. Similar, but incomplete typologies have been created by F. Papò,<sup>8</sup> G.C. Boon,<sup>9</sup> M.P. Mercanti<sup>10</sup> and G. Kapitän.<sup>11</sup>

TABLE 1. WOODEN-ANCHOR STOCK TYPOLOGY

<u>Type</u>	<u>Stock</u>
I	Stone
IIA	Wooden with lead core separated by shank
IIB	Wooden with lead core joined through shank
IIIA	Solid lead with no internal junction with shank
IIIB	Solid lead with lead tenon through shank
IIIC	Lead with wooden core
IVA	Removable; solid lead with stop
IVB	Removable; solid lead without stop

Available epigraphic, archaeological, physical and literary evidence can be organized into three categories: dating, reconstruction, and use; implementing my typology, I will clarify gaps in the understanding of each anchor type in all three categories. Information used in the thesis derives from ancient literary references, archaeological reports, and original research conducted on anchor remains.

It is hoped that this thesis will bring organization and clarity to an often confused and muddled aspect of maritime history.

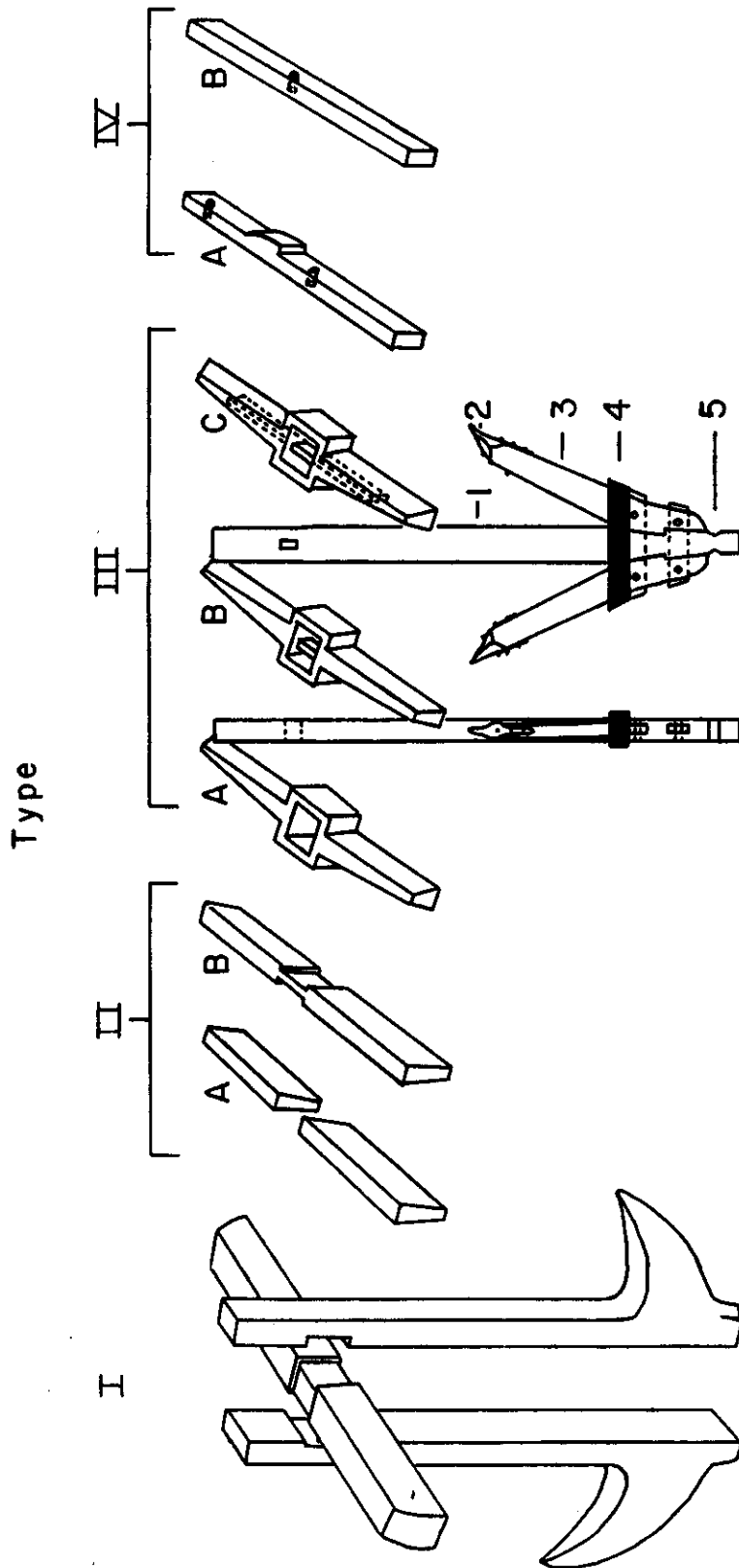

III. 1. Types of wooden anchor stocks with 1) shank, 2) fluke point or 'tooth', 3) arm, 4) reinforcement collar, and 5) crown (Type I-stocked anchor adapted from F. Benoit, "Nouvelles et correspondance," RA (1951)225, Fig. 8. Type II, III and IV-stocked anchor adapted from G.C. Speziale, "The Roman Anchors found at Nemi," MM 17 (1931)315, Fig. 2). Illustration not to scale.

## DATING

Ancient authors disagree about origin of wooden anchors. Strabo attributes the invention to Anacharsis (fl. 592 B.C.);<sup>12</sup> Pliny, to Eupalamus and Anacharsis;<sup>13</sup> and Pausanias, to Midas (738-696 B.C.).<sup>14</sup> The earliest certain evidence of wooden anchors is the employment of the Greek word ankura, "anchor", or "bent", by Alcaeus (c.620-580)<sup>15</sup> around the end of the seventh century B.C. This word came to replace the word eunai, or "bed", commonly thought to refer to earlier stone anchors.<sup>16</sup>

It is unlikely that a precise determination of the origin of wooden anchors will ever be made. Modern authors have suggested that they developed from the killick,<sup>17</sup> were Greek imitations of earlier Chinese anchors,<sup>18</sup> or were modified stone anchors.<sup>19</sup> In any case, the classical word for anchor stock was "stone";<sup>20</sup> presumably the first stocks used were of stone, and the name for any subsequent type of anchor stock remained "stone".

Coinciding with literary evidence, the earliest archaeologically dated stone stocks, from Cyprus,<sup>21</sup> Punta della Ristola, and Metaponto,<sup>22</sup> date between the late seventh and early sixth centuries B.C. A type I stock was excavated from the Dattier wreck dating to the second half of the sixth century.<sup>23</sup> Votive stone anchor stocks have been found at Gravisca and Crotone<sup>24</sup>. One of the Gravisca

stocks can be dated to the end of the sixth century B.C.; the Crotone stock, to the first quarter of the fifth century. The latest dated stone stock comes from the mid-fourth-century Sec wreck at Palma di Mallorca,<sup>25</sup> indicating the continued use of stone stocks throughout the fifth century and well into the fourth century.

Lead, becoming more available in the fourth century, replaced stone as an integral part of wooden anchors. Since lead was more malleable, denser, and more resistant to stress than stone, the use of stone stocks diminished.<sup>26</sup> Ancient navigators at first replaced stone stocks with lead-cored wooden stocks.

Between 60 and 30 B.C., Diodorus of Sicily, describing earlier Phoenician merchants in Spain, wrote:

"So far indeed did the merchants go in their greed that, in case their boats were fully laden and there still remained a great amount of silver, they would cut the lead out of the anchors and have silver perform the service of the lead."<sup>27</sup>

Authors of the mid-nineteenth century believed Diodorus used ekoptein to mean "cut out."<sup>28</sup> However, later authors interpreted the word as "cut off" and confused type II wood/lead core with type IIIC lead/wood core stocks.<sup>29</sup> In the 1950s, when associated type II stock halves came to light, scholars reexamined Diodorus' passage and recognized the type II stock.<sup>30</sup> One wishes there could be as much dating evidence as there is controversy about this stock

type.

Possibly the earliest example of a type IIA stock comes from the late-sixth-century wreck at Bon Porte.<sup>31</sup> Following this are wood/lead core stocks found in the forward part of a Greek wreck off Porticello, Italy, dated to the late fifth or early fourth century.<sup>32</sup> Further examples of lead-cored stocks have been found on the late-fourth-century Kyrenia wreck in Cyprus,<sup>33</sup> and on the Graeco-Italic wreck at La Secce di Capistello, Italy, which dates to the first quarter of the third century.<sup>34</sup> The latest example of a type IIA stock was recovered from the mid-second-century B.C. wreck at Isla Pedrosa, Spain.<sup>35</sup> Use of type II stocks diminished during the late third and early second centuries B.C.

Currently, all type IIB stocks come from undated contexts;<sup>36</sup> however, they may have been transitional between type IIA and its successor, type IIIB, a solid lead stock with a lead tenon through the shank. If so, the development of type IIB would have occurred between the last half of the third and the first half of the second centuries B.C., when type IIIB appears.

On the basis of both reliefs cast on type III stocks and general contextual evidence, authors have dated solid lead stocks from the sixth century B.C. to the second century A.D.<sup>37</sup>

Examples of type IIIB stocks have been found on wrecks

dating from possibly as early as the late third to the late first century B.C. The mid-second-century Greco-Italic wreck at Punta Scaletta, Italy, provides the earliest secure archaeological evidence for IIIB stocks.<sup>38</sup> Other examples of IIIB stocks were recovered from the wrecks of Planier A,<sup>39</sup> Jeaune Garde and Grande Ribaud,<sup>40</sup> Sa Nau Perduda,<sup>41</sup> and Cavalière,<sup>42</sup> all dated to the last half of the second century B.C. Other stocks of this type were found on wreck A at Antheor,<sup>43</sup> and the Mahdia wreck,<sup>44</sup> dated to the early and middle first century B.C. respectively. German discoveries of Roman legionary anchors have extended the date of type IIIB stocks to A.D. 70.<sup>45</sup>

Although authors have hypothesized about the typological development of type IIIC stocks,<sup>46</sup> only two wrecks provide secure archaeological contexts: wreck C at Chrétienne dated to the second half of the second century B.C.,<sup>47</sup> and the Nemi barges of A.D. 41-65.<sup>48</sup> With this paucity of evidence, we must assume constant IIIC use throughout this period.

Originally thought to date as early as the sixth century B.C.,<sup>49</sup> the type IIIA stock dates epigraphically to the late Republican and early Imperial periods. A IIIA stock bearing the name AHENOBARBUS was found near Sicily and, due to its illegibility, was dated to the second century A.D.<sup>50</sup> However, the Ahenobarbi were a powerful

late Republican family, so the stock may date as early as the late first century B.C. Another example of a type IIIA stock was recovered near Santa Maria di Castellabate, Italy; it bears the name C AQUILLI PROCUL on both arms.<sup>51</sup> This stock is attributed to Caius Aquillius Proculus, who served as consul in A.D. 90 and as proconsul of Asia in A.D. 103/4.<sup>52</sup> Lucian, writing after A.D. 120, speaks of wood and lead anchors.<sup>53</sup> The latest evidence for wooden anchors is a type III stock from Cartagena, Spain, bearing the name L V LUPO.<sup>54</sup> This can be attributed to L. Virius Lupus, who served as consul in 232 A.D.<sup>55</sup>

Evidence for removable, or type IV, stocks comes not from wooden anchors, but from iron anchors recovered from the Punta Scaletta wreck.<sup>56</sup> No type IV stock for a wooden anchor has been found in a secure archaeological context.<sup>57</sup> Wooden anchors with removable lead stocks were inspired by or served as substitutes for iron anchors with removable stocks.

Although mentioned by Herodotus in the fifth century B.C.,<sup>58</sup> the earliest archaeologically dated iron anchors were recovered from the Graeco-Italic wrecks at Isola di Monte Cristo<sup>59</sup> and La Secce di Capistello,<sup>60</sup> dated to the late fourth century and first quarter of the third century B.C., respectively. Iron anchors were initially used in conjunction with wooden anchors; Athanaeus mentions four wooden and eight iron anchors belonging to the grain ship

Siracusia in 240 B.C.<sup>61</sup> Simultaneous use is seen at Isla Pedrosa in the mid-second century B.C. and continued at least until the first century A.D., as shown by the Nemi and Dramont D wrecks.<sup>62</sup> Only iron anchors were recovered from the Dramont F wreck<sup>63</sup> which dates to the fourth century A.D. Evidently, after the first century A.D., the use of wooden anchors declined and was finally eclipsed by iron anchors toward the end of the Roman period in the late third century A.D.

Given limited dating precision and sometimes over-extended dating evidence, one perceives that stock types fall into periods which are related to historical developments. The stone stock, developed in the late seventh century B.C., survived 250 years in spite of its fragility, low density, and the painstaking labor necessary for its creation. However, at the end of the fifth century B.C., an improvement in anchor stock manufacture was made: lead-cored wooden stocks were introduced.

Major sources of lead in antiquity were Italy, Sardinia, Spain, Greece, Egypt, Asia Minor and Britain.<sup>64</sup> In the late fourth and third centuries B.C., these sources were divided among the many nations controlling the Mediterranean (ill. 2).



Ill. 2. Lead sources in the ancient Mediterranean: 220 B.C. (adapted from C. McEvedy, The Penguin Atlas of Ancient History [New York 1967] 65).

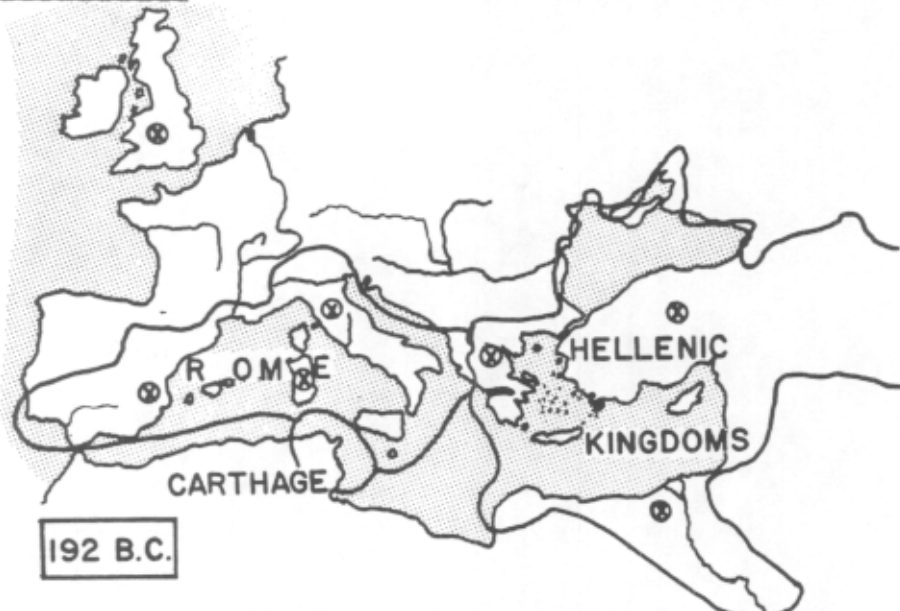

Ill. 3. Roman expansion in the ancient world: 192 B.C. (adapted from C. McEvedy, The Penguin Atlas of Ancient History [New York 1967] 67).

But in the early second century B.C., Rome wrested most of the western Mediterranean from Carthage and consolidated three major lead sources in Italy, Sardinia and Spain (ill. 3). By the mid-second century B.C., our earliest secure date for type III stocks, Rome added the Greek lead mines to its holdings (ill. 4). Eventually Egypt, Asia Minor and Britain fell under the Roman aegis. As a steady supply of lead became more reliable in the western Mediterranean, the amount of lead used in anchor stocks increased.

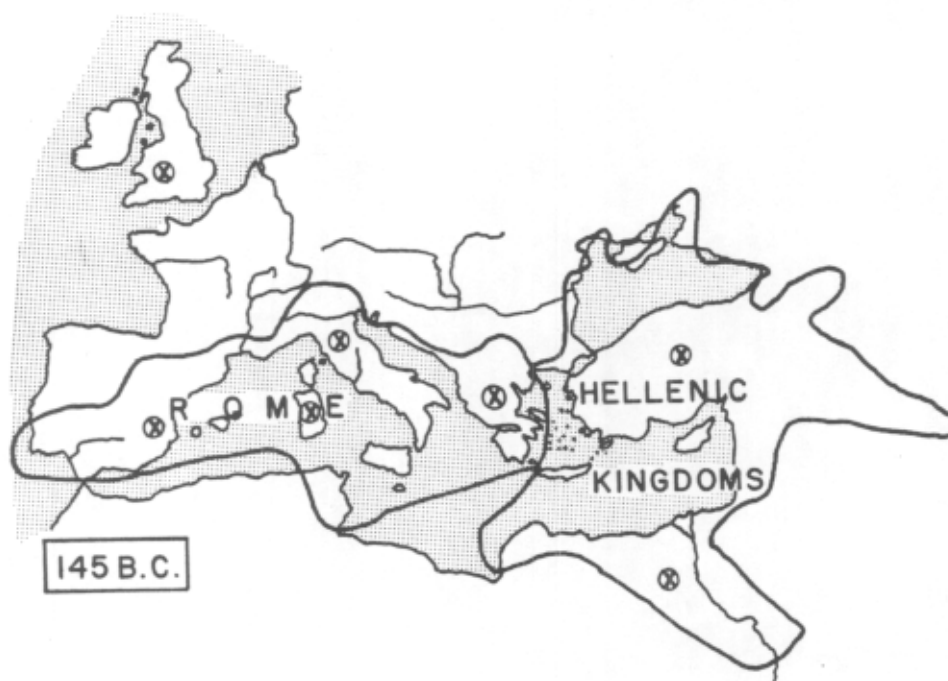

Ill. 4. Roman consolidation of lead sources in Spain, Sardinia, Italy and Greece: 145 B.C. (adapted from C. McEvedy, The Penguin Atlas of Ancient History [New York 1967] 69).

The latest date for type II stocks is the mid-second

century B.C., but introduction of type III stocks may have been somewhat earlier. When Rome consolidated lead sources in the early second century B.C., economic considerations which had formerly restricted extensive lead use were eliminated. The proliferation of type III stocks may be dated to the second quarter of the second century B.C. and credited to Roman expansion (ill. 5).

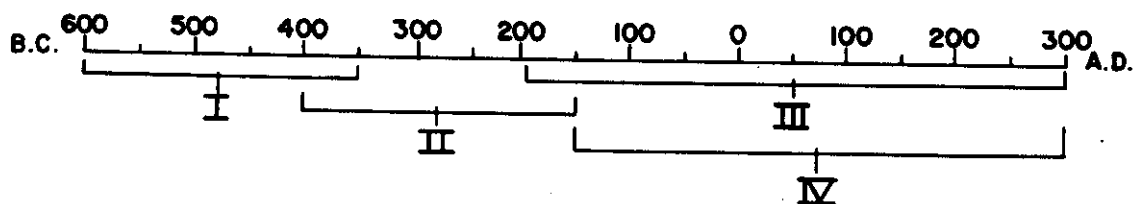

### Ill. 5. Chronology of wooden-anchor stocks.

It is uncertain why wooden anchor use declined in the late third and early fourth centuries A.D. When the use of large ships of over three hundred tons burden diminished in the late Roman period, extra space on board provided by the removable-stocked iron anchors became even more essential. On a small boat, an iron anchor was easier to handle than a wooden anchor. Inherent weaknesses in wooden anchor construction compared to the durability of iron anchors born of a developing knowledge of ironworking probably led to a predominate use of iron anchors in the first century A.D. and their sole use by the fourth century.<sup>65</sup>

## RECONSTRUCTION

The stone-stocked anchor is best represented on the coins of Apollonia Pontica (ill. 6). The anchors appearing on these coins have been identified incorrectly as mushroom anchors,<sup>66</sup> anchors made of bronze,<sup>67</sup> and anchors having palms.<sup>68</sup> Also, ironically, early anchor reconstructions involving type IIIB stocks resemble these stone-stocked anchors more closely than the lead-stocked wooden anchors that have been recovered (ill. 7 and 8).<sup>69</sup> Noting the central groove on stone stocks, G. Kapitán resolved the enigma of the stone-stocked anchor by theorizing that the shank had consisted of two pieces of wood between which the stock was placed (ill. 9).<sup>70</sup>

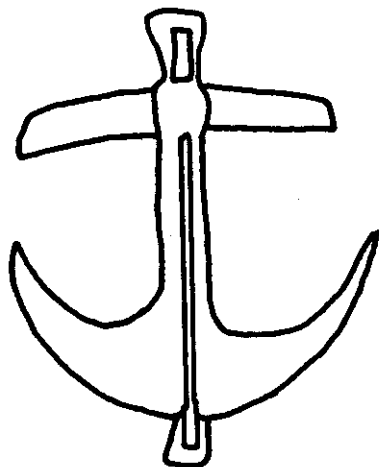

Ill. 6. Stone-stocked, wooden anchor from Apollonia Pontica coin dated 350 B.C. (adapted from the National Maritime Museum of Haifa, Ships and Parts of Ships on Ancient Coins vol. 1 [Haifa 1975] 68, fig. 63).

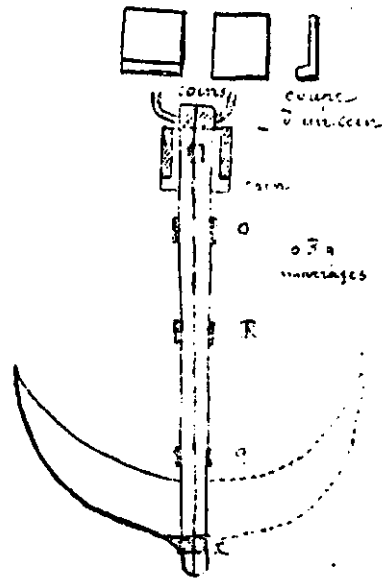

Ill. 7. Reconstruction of a type III-stocked anchor (from L. Magnon, "Essai de reconstitution de l'ancre du Musée d'Archéologie de Marseille," RA 2 [1894] 226, fig. 9).

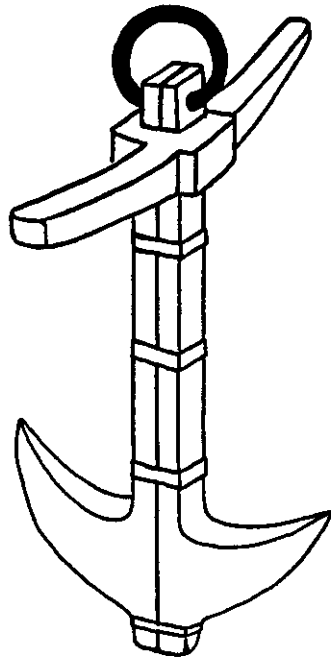

Ill. 8. Illustration of a type III-stocked anchor with a bipartite shank (from F. Benoit, "Nouvelles et correspondance," RA [1951] 225, fig. 8).

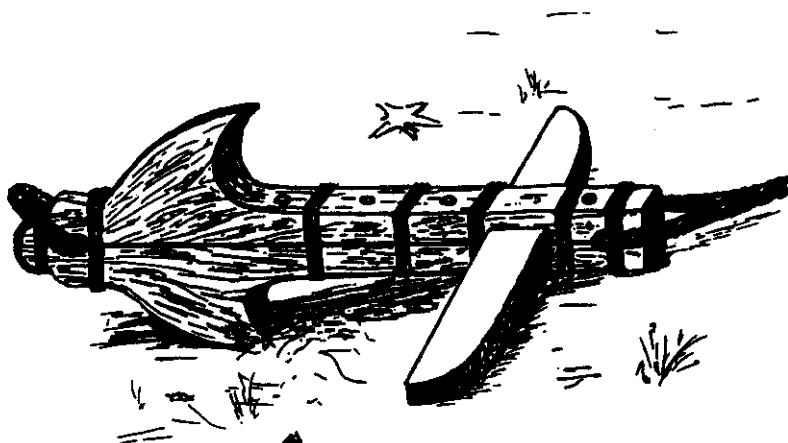

Ill. 9. Kapitän's reconstruction of the stone-stocked wooden anchor (from G. Kapitän, "On Stone-Stocked Greek Anchors as found in Thracia Pontica: Suggested Reconstruction of their Wooden Parts," Thracia Pontica I [Sofia 1982 296, fig. 5]).

Early stone-stocked anchors were manufactured from tree crotches, the hook formed by a branch and the trunk of a tree. These were cut, trimmed and fit back-to-back. A system of mortise-and-tenon fastenings or lashing may have been used to bind the two crotches together.<sup>71</sup> Compared to that of later anchor-arm construction, the strength of each crotch was considerable since the arms were not scarfed to a separate shank, but were an extension of the shank. When a crotch broke or, more often, wore down, it was replaced by another crotch.<sup>72</sup> The weakest element of early wooden anchors was the stone stock. When stone stocks were replaced by lead stocks, the necessity for two-crotched anchors no longer existed; one-piece shanks became the rule.<sup>73</sup>

Remnants of wooden anchor shanks indicate they were commonly made of oak<sup>74</sup> and often cut to a rectangular section with a width one and one-half times the thickness.<sup>75</sup> No conclusive evidence concerning the normal relationship between shank length and other anchor dimensions exists.<sup>76</sup> Extant remains of wooden anchor shanks from Nemi and Elba (ill. 10; figs. 1 and 2, pl.1) do not exhibit lower shank bulges similar to that of the iron anchor from Nemi (ill. 11).<sup>77</sup>

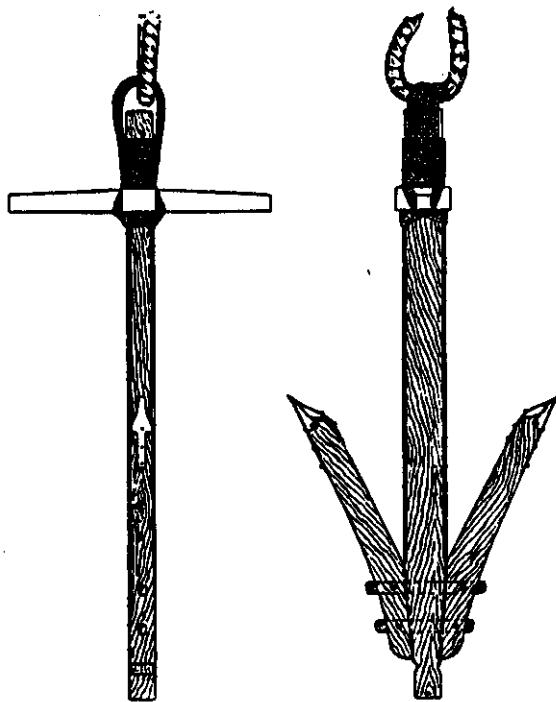

Ill. 10. The wooden anchor from Lake Nemi (from G. C. Speziale, "The Roman Anchors found at Nemi," MM 17 [1931] 315, fig. 2). Scale 1:70.

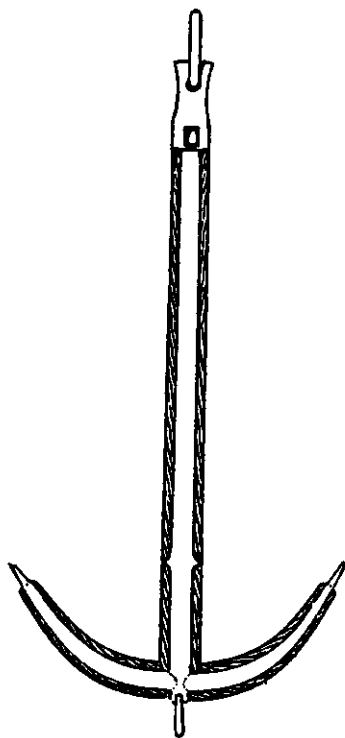

Ill. 11. The iron anchor from Nemi (from G. C. Speziale, "The Roman Anchors found at Nemi," MM 17 [1931] 314, fig. 1). Scale ca. 1:45.

The shank of the Nemi anchor tapered toward the crown to create a butt joint between the shank and arms. This joint appears to be exceptional, however, since anchor remains from Isola Lunga, Haifa,<sup>78</sup> Elba and the Chrétienne C wreck all have a hook joint, best represented by the Chrétienne C remains (ill. 12). All of the above mentioned anchors, except the one from Isola Lunga, display a notched crown.<sup>79</sup>

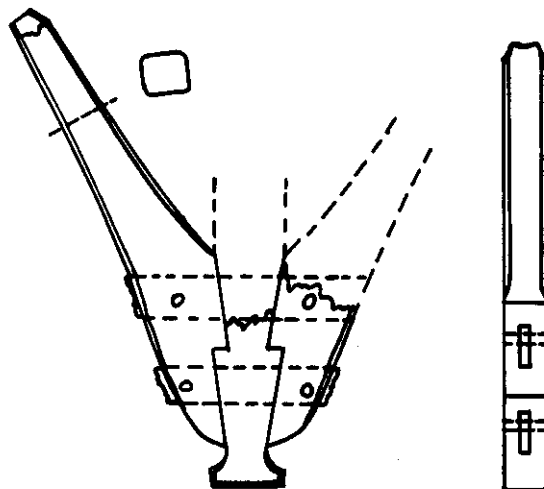

Ill. 12. The wooden anchor remains from Chrétienne C (adapted from J.-P. Joncheray, "L'épave 'C' de la Chrétienne," CAS 1st supplement [1975] 106, fig. 51). Scale 1:17.

Surviving portions of anchor arms indicate they were also made of oak and attached to the shank with mortise-and-tenon fastenings secured with pegs in either arm (ill. 11 [p. 18], 12; fig. 1, pl.1). The tenons projected outside the arms.<sup>80</sup> The arm ends were reinforced with small tooth-like bronze or iron cones, known in ancient times as the "teeth" of an anchor, which enabled it to dig into the seabed (ill. 10 [p. 17] and 13).<sup>81</sup> The "teeth" were fastened to the arms with nails.<sup>82</sup>

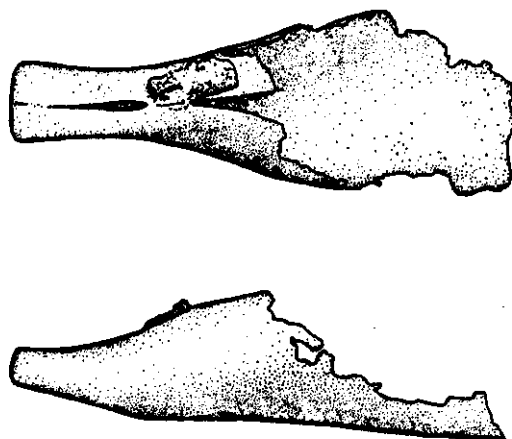

Ill. 13. Bronze "tooth" from Porticello (from C. J. Eiseman, The Porticello Shipwreck: A Mediterranean Merchant Vessel of 415-385 B.C., [unpublished dissertation, Philadelphia, 1979] 68, fig. 2.34). Scale 1:3.5

Many examples of the lead collars employed in reinforcing the arm/shank junctions of wooden anchors have been recovered from the sea. A reinforcement collar reveals the angle formed between each arm and the shank of the anchor on which it was used. This angle varies between 22 and 43 degrees, the average angle being 27 degrees (ill. 14B).<sup>83</sup> However, this angle variance does not appear to reflect any general change in the arm angle of wooden anchors over time, as was the case with iron anchors.<sup>84</sup> The Chrétienne C anchor arms were set at 30 degrees, while those on the later Nemi anchors were set at 26 degrees.<sup>85</sup>

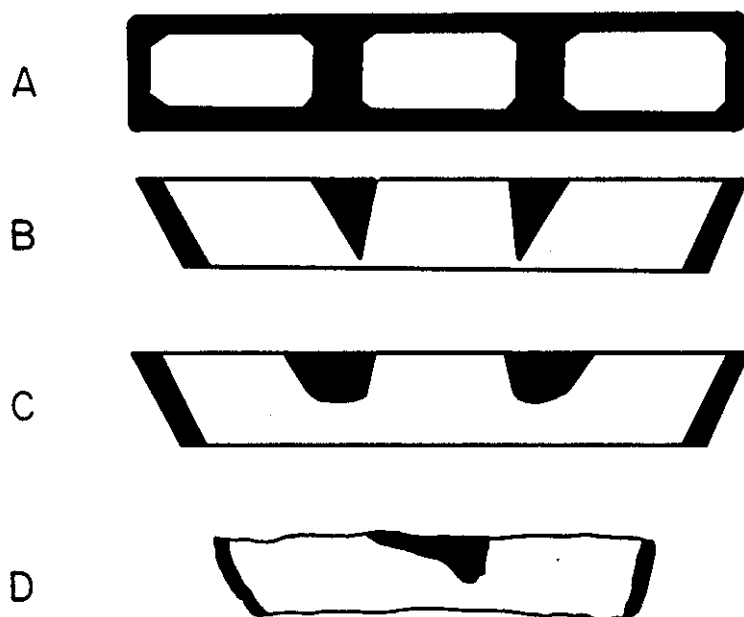

Ill. 14. Schematic cross section of reinforcement collars: A) top view, B) side view with angular arm/shank junction, C) side view with rounded arm/shank junction, D) one-armed anchor reinforcement collar from Brindisi (from G. Kapitän, "New Evidence of Ancient Anchors," Archaeology 24 [1971] 53). Scale 1:4.

When construction of an anchor was completed, the arm and shank edges were beveled (ill. 12, p. 19).<sup>86</sup> The random occurrence of bevels in shank boxes of type III stocks suggests that anchors were not always beveled before stocks were poured.<sup>87</sup> On the other hand, reinforcement collars frequently display bevels on all arm and shank edges (ill. 14A), suggesting that the collars were not integral anchor parts,<sup>88</sup> but were added later to strengthen the arm/shank junction.<sup>89</sup>

Two different types of arm/shank junctions are seen in reinforcement collars: angular and rounded (ill. 14B and C, p. 21).<sup>90</sup> Angular junctions are clearly evident on the Nemi and Chrétienne C anchors, but no remnants of wooden anchors with rounded arm/shank junctions have come to light. Evidence of rounded junctions suggests that either the arms in this case met the shank with a shallow curve, or there were some wooden anchors with lunate, as opposed to the characteristic V-shaped, arms. Without direct physical evidence, however, it is difficult to support the latter contention.

Although the one-armed anchor was known in Greece and Egypt,<sup>91</sup> reinforcement collars provide the only physical evidence of its use (ill. 14D, p. 21).<sup>92</sup> Continual use of one arm with an angle of about 60 degrees to the shank<sup>93</sup> necessitated that arm's reinforcement. In view of the rarity of one-armed reinforcement collars and infrequent mention of one-armed anchors in ancient texts, this type of anchor may have been used only locally and on small boats.<sup>94</sup>

Other forms of anchor reinforcement are two types of lead collars that strengthened the heads of removable stocked anchors (ill. 15 and 16). Stresses on anchor heads caused cracks to form in the wood; the first type of collar filled and reinforced damaged wood.<sup>95</sup> The second type of reinforcement collar is known inappropriately as the

"arganeo" or "head ring".<sup>96</sup> Although no examples of the latter type of collar have been found on anchor heads, their rectangular form and the facing rectangular holes on their sides suggest that they reinforced the shank hole of removable-stocked anchors.<sup>97</sup> A slight depression on the head of the Elba anchor indicates where this type of collar may have been placed (figs. 1 and 2, pl. 1).

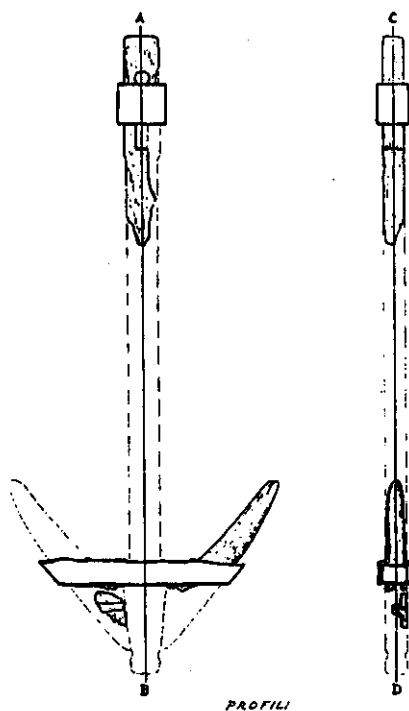

Ill. 15. Anchor remains with head reinforcement collar from Isola Lunga (adapted from G. Kapitän, "Rinvenuta nel mare dell'Isola Lunga un'ancora antica a ceppo smontabile," Sicilia Archeologia 16 [December 1971 17, fig. 2).

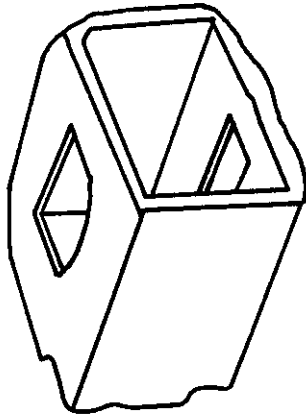

Ill. 16. Type IV-A stock head reinforcement collar (adapted from J. Bravo, "Arqueología submarina: Algo más sobre el ancla llamada romana," CRIS 57 [1963] 5).

In view of the often great size and weight of lead anchor stocks, they were probably the last, major addition in anchor construction. Even though no wooden remains of type II stocks survive, wood impressions have been found on type IIA and B cores.<sup>98</sup> Evidently, a wooden box fixed to the shank contained the cores. Any combination of six precautions was taken to prevent the cores from slipping and destroying the box: stones placed in the box before pouring;<sup>99</sup> holes drilled into the box into which the lead flowed; (ill. 17);<sup>100</sup> iron nails driven into the box from outside;<sup>101</sup> dovetail mortises cut into the box which the lead filled (ill. 18);<sup>102</sup> a tenon in the bottom of the box perpendicular to the longitudinal shank axis was covered with lead during the pour or by wood when the box was

completed after the pour (ill. 17);<sup>103</sup> and a channel cut through the shank into which the lead flowed uniting the cores (ill. 19).<sup>104</sup> The walls of the box formed a trapezoidal cavity with the broad side at the top of the stock.<sup>105</sup> When preparations were complete, molten lead was poured into the cavity.<sup>106</sup>

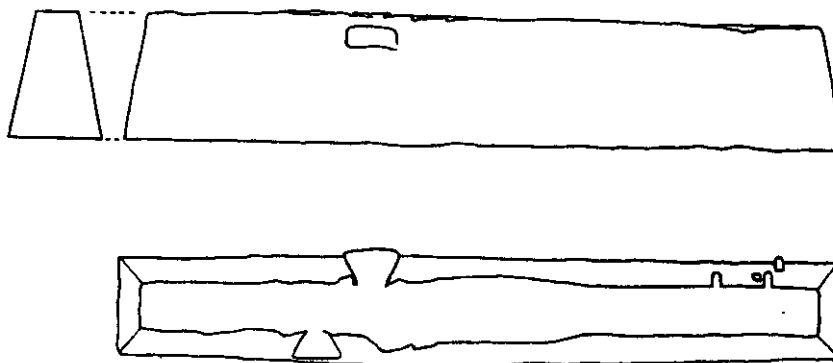

Ill. 17. Lead core of wooden stock from Porticello (from C. J. Eiseman, The Porticello Shipwreck: A Mediterranean Merchant Vessel of 415-385 B.C. [unpublished dissertation, Philadelphia, 1979] 65, fig. 2.29). Scale 1:9.

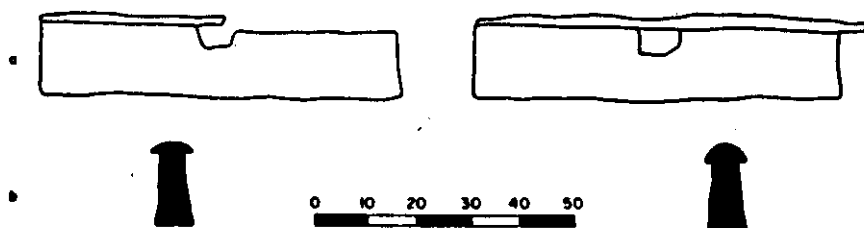

Ill. 18. Type IIa stock cores from Cape Graziano (from G. Kapitän, "Exploration at Cape Graziano, Filicudi, Aeolian Islands, 1977," IJNA 7 [1978] 272, fig. 59).

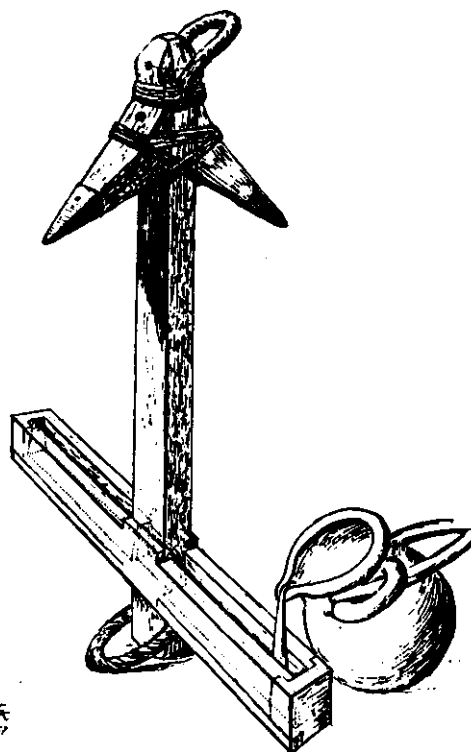

Ill. 19. Creation of a type IIB-stocked anchor (from G. Kapitän, "Meerzarchäologie in Bulgarien--Ankerfunde im Schwarzen Meer," Das Logbuch 16 [1980] 48, fig. 8).

Associated type II cores are not always equal in weight;<sup>107</sup> this has caused some authors to suggest that type IIA stocks were used with one-armed anchors,<sup>108</sup> or that a lighter core was set further away from the shank than a heavy core to balance the anchor.<sup>109</sup> Lead ingots were one of the few large lead forms of specific weight in antiquity.<sup>110</sup> Lead stocks,<sup>111</sup> on the other hand, were rarely poured to specific weights, and this seems to be a more likely reason for such imbalances.

For manufacture of type III stocks, a mold was formed in a sand or clayey-sand matrix.<sup>112</sup> The sides of the mold sloped up and out from the bottom to insure complete filling and to facilitate removal after pouring (ill. 20).<sup>113</sup> Mold dimensions followed one of several formulas. (Appendix 1.)

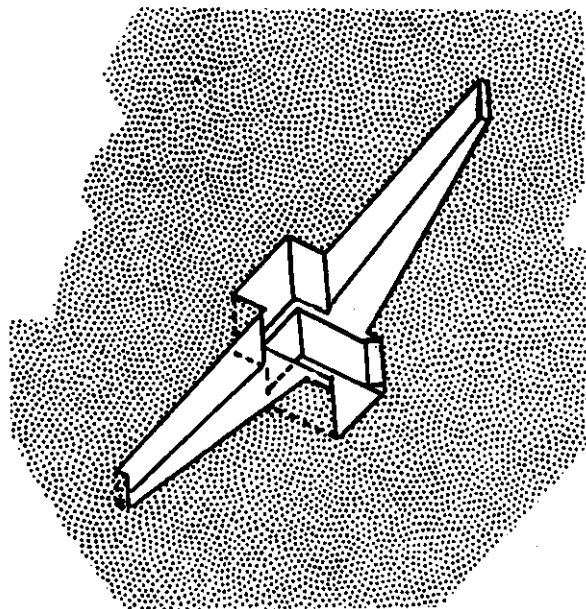

Ill. 20. Cross section of a type III anchor-stock mold.

Occasionally, the sides of the mold arms were impressed with astragals: anklebones of sheep and goats used in ancient dice games.<sup>114</sup> Each of the four sides of an astragal was impressed in an end-to-end, side-to-side, or scatter pattern,<sup>115</sup> signifying the best, or "Venus", throw of the dice.<sup>116</sup> Although thought to have had religious value,<sup>117</sup> or power against the "evil eye",<sup>118</sup> astragal impressions can be interpreted by their allusion--a throw. Astragals enabled an anchor, thrown from a ship, to land correctly on the seabottom.<sup>119</sup>

To insure an anchor's continued hold on the seabottom, attributes of divinities were impressed into type III stock molds: severed (Medusa) heads, scallop shells, dolphins and tritons.<sup>120</sup> Names of deities themselves were inscribed into stock molds as a direct appeal for a firm grasp on the seabed.<sup>121</sup> Divine names and attributes were probably seen as apotropaic devices to ward away mischievous sea spirits who might trip anchors and cause ships to wreck. Certainly the Medusa head was one such device.

Impressions of lead rings, similar to one recovered from the Porticello wreck (ill. 21), give the only secure evidence of the rings' use.<sup>122</sup> Not only did astragals enable the anchor to fall correctly, but rings, used to free fouled hawsers,<sup>123</sup> insured an anchor's smooth recovery.

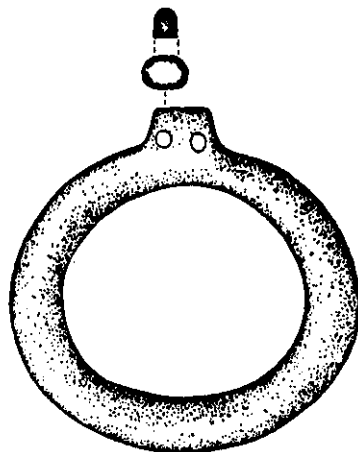

Ill. 21. Hawser ring from Porticello (from C. J. Eiseman, The Porticello Shipwreck: A Mediterranean Merchant Vessel of 415-385 B.C. [unpublished dissertation, Philadelphia, 1979] 80, fig. 2.54). Scale 1:6.

To prevent theft, anchor-stock molds were inscribed with the names of ships or shipowners.<sup>124</sup> Finally, a maker's mark could be pressed into a stock mold.<sup>125</sup>

After the mold was prepared, the shank, with a tenon channel for a type IIIB stock,<sup>126</sup> or wooden crossbar for a type IIIC stock, was placed, inverted, into the mold center (ill. 22); pieces of ceramic or stone were placed under type IIIC wooden crossbars to keep them level during the pour.<sup>127</sup> Lead, heated to about 475 degrees centigrade, was poured into the mold next to the anchor shank.<sup>128</sup> Normally, stocks were made in one pour.<sup>129</sup> Contraction trenches and holes frequently formed on the upper side of the pour as the stock cooled.<sup>130</sup> After the lead cooled, anchor and stock were removed from the mold. Occasionally,

inscriptions involving names,<sup>131</sup> arsenal numbers,<sup>132</sup> maker's marks, and, rarely, weights<sup>133</sup> were cut into stocks.

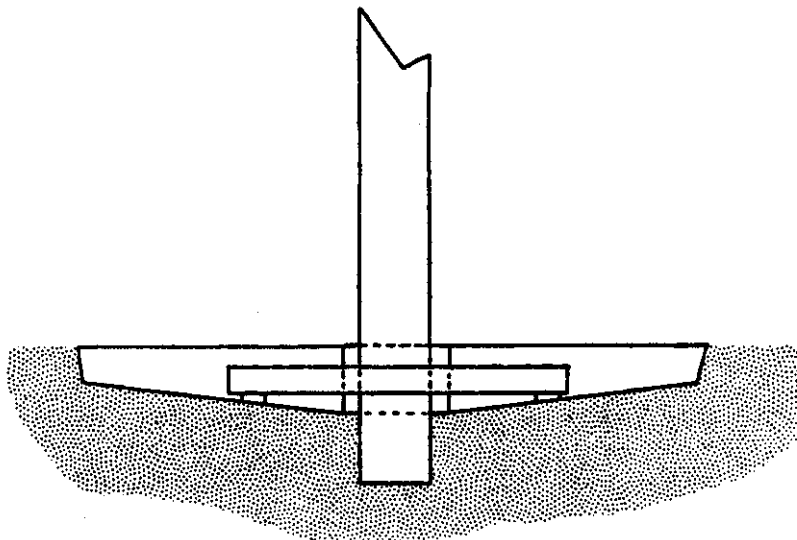

Ill. 22. Cross section of a wooden anchor and mold prior to pouring.

The final addition in wooden anchor construction was the head ring. In the Nemi example, a rope was lashed around the stock and looped over the head several times (ill. 10).<sup>134</sup> This, in turn, was bound to the sides of the shank with additional rope. Head rings for removable-stocked anchors were simply holes drilled through the head.<sup>135</sup>

Only type IV stocks were poured separately and later mounted in shanks. To produce a type IVA stock, a shallow straight-sided mold was made with clay (ill. 23).

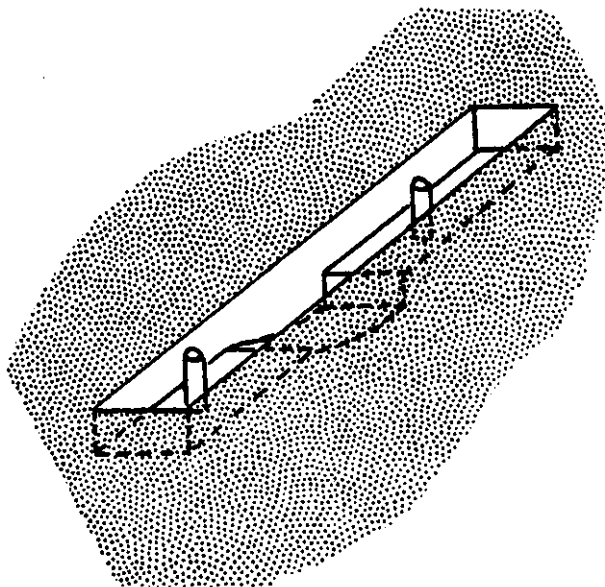

Ill. 23. Mold for a removable stock.

Impressions of astragals, inscriptions, or stamps were made on the bottom surface of the stock mold's standing end,<sup>136</sup> that is, the end of the stock that did not pass through the shank. A sloping or rectangular depression was made for the stop. Two holes for the retrieval rope and stop pin<sup>137</sup> were made with cylinders of wood or clay placed at the standing end and center of the mold respectively. Type IVB stock molds differed through the absence of decoration and the presence of only a single, central stop-pin hole. In some rare examples of type IVA stocks, a wooden core was placed in the mold before pouring.<sup>138</sup> When preparations were complete, lead was poured; when the lead cooled, the stock was removed and ready for use.

## USE

Evidence for the number of anchors used by ships is sometimes found on shipwrecks. However, since a ship in distress will cast anchor to save itself, the number of anchors recovered from a wreck may not represent the original complement. Numbers of anchors on shipwrecks vary (appendix 2).<sup>139</sup> The number of anchor stocks recovered from shipwrecks ranges between one and seven. The largest recorded complement of anchors in antiquity, twelve, was carried on board the 1,760 metric ton behemoth Siracusia,<sup>140</sup> but this is an exceptional case. Although the recovered anchor stocks recorded in Appendix 2 probably do not represent the original complements of anchors on board, their number, weight and size generally increase proportionally to an increase in ship size. Further relationships are percentages of ship's length and beam represented by anchor stock lengths. Stock lengths range between 6% and 10% of ship lengths with an average of 6.6%. Moreover, percentages of ship beam measurements vary between 14% and 30% with an average of 22%: approximately one-quarter. While this evidence is not conclusive, it does suggest that both the number of anchors aboard ship is related to ship size, and that anchor stock and ship size may be related.

A large number of wooden anchors became a hazard on

deck. Thus, either larger, heavier anchors were used or several iron anchors, for light everyday work, were substituted. The first alternative appears to have been the case at Mahdia, the latter at Punta Scaletta and on the Siracusia. The bulk of so many wooden anchors on deck was impractical and to increase their weight would only have added strain to the lifting devices.<sup>141</sup> As ship size increased in the Roman period, extensive, simultaneous use of wooden and iron anchors was inevitable.

The "sacred" or sheet anchor was the largest anchor carried; the sheet anchor stock from Mahdia is twice as large as the other stocks.<sup>142</sup> The "sacred" anchor was thrown as a last hope of desperate sailors on a ship about to wreck.<sup>143</sup>

The best description of anchoring in antiquity is found in The Acts of the Apostles, in which Paul's storm-besieged ship anchors off Malta:

"And sounded, and found it twenty fathoms: and when they had gone a little further, they sounded again and found it fifteen fathoms. Then fearing lest we should have fallen upon rocks, they cast four anchors out of the stern and wished for the day. And as the shipmen were about to flee out of the ship, when they had let down the boat into the sea, under colour as though they would have cast anchors out of the foreship..."<sup>144</sup>

The anchoring of Paul's ship is not unusual; sounding leads are recovered frequently in the Mediterranean.<sup>145</sup> Anchor stocks are often found at an average depth of 27 meters,

quite close to Paul's 15 fathoms (30 meters). In addition, anchoring off bow and stern in a storm was not unusual.<sup>146</sup> Ships commonly anchored at either end;<sup>147</sup> one or two anchors were considered sufficient in mild weather.<sup>148</sup>

Anchor hawsers were of hemp cable about 5 to 15 centimeters in diameter;<sup>149</sup> chain was rarely used.<sup>150</sup> Although modern authors suggest that hawsers ran through hawsepipes, no conclusive evidence of hawsepipes has come to light.<sup>151</sup> Anchor hawsers may have been led over the ship's side.

A line from the crown led to a cork float which marked the anchor's position on the sea-bottom.<sup>152</sup> If necessary, the float line could be pulled to dislodge an anchor.<sup>153</sup> To disentangle a fouled anchor, a lead ring (ill. 23) on a rope was slipped over the inboard hawser end and slid down to the tangle.<sup>154</sup> From the ship's boat a sailor could work the ring down with the rope and free a snagged or fouled hawser.<sup>155</sup>

Any one of three mechanisms were used to raise anchors: windlass, capstan or artemon (pl. 2) with a pulley or system of pulleys.<sup>156</sup> When raised, anchors were hung on a cathead, rail,<sup>157</sup> or brought inboard.

## CONCLUSION

Although the evidence for wooden anchors varies from weighty to nonexistent, enough information can be gleaned to provide an outline of their history. During the age of wooden anchors, four different stock types were used: stone, wood with a lead core, lead, and removable lead stocks. Chronologically, the use of each type overlapped. Stone-stocked wooden anchors did not entirely replace stone anchors in the seventh century; neither was there an abrupt shift from stone to wood/lead core stocks in the mid-fourth century. Transition to solid lead stocks from wood/lead core stocks in the early second century was not complete until the middle of that century. Each succeeding stock type appears about fifty years before the latest dated example of its predecessor. In the dynamic system of wooden anchor development and obsolescence, the final victor was the iron anchor. Wooden anchors were heavy, tended to decay and required too much storage space. As ships became smaller in the late Roman period, efficient utilization of space became more essential and heavy, cumbersome, wooden anchors were no longer required on board.

For all the improvement in wooden-anchor-stock technology, evidence for construction of the anchors themselves points to two forms of shanks: one and two

piece. When stone stocks were replaced by lead stocks bipartite shanks were no longer necessary. The strength sacrificed by abandoning two-crotched anchors was compensated for by reinforcement collars. These collars yield an abundance of information about anchors including the one-armed and, possibly, the lunate-armed wooden anchor. Further, predetermined formulas were employed in anchor-stock construction.

Between two and twelve anchors were used on ancient ships and were cast from either bow or stern. No matter how great the weight of wooden anchors, devices for raising them were available throughout their history.

As we have seen, our understanding of wooden anchors has increased considerably in recent years, but much remains to be learned concerning their dating, construction and use. New discoveries of anchor remains can no longer be viewed as pedestrian finds, but as additional pieces for a puzzle whose solution has just begun.

## PLATES

## PLATE I



Fig. 1. The Elba anchor (from A. Maggiani, "Isola d'Elba," BdA 4th supplement Archeologia subaquea [1982] 63, fig. 30).

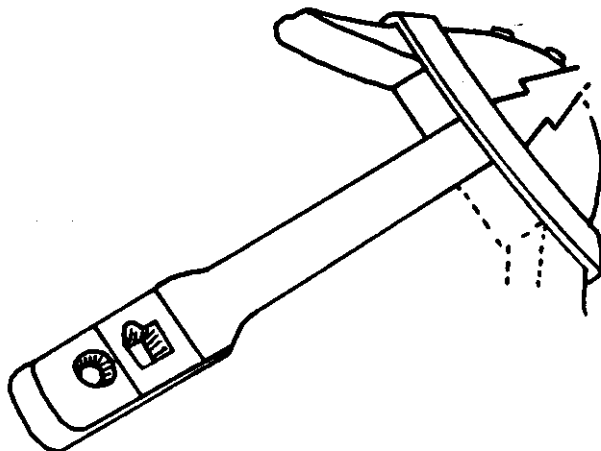

Fig. 2. Physical evidence discernible on the Elba anchor (from A. Maggiani, "Isola d'Elba," BdA 4th supplement Archeologia subaquea [1982] 63, fig. 30).

## PLATE II

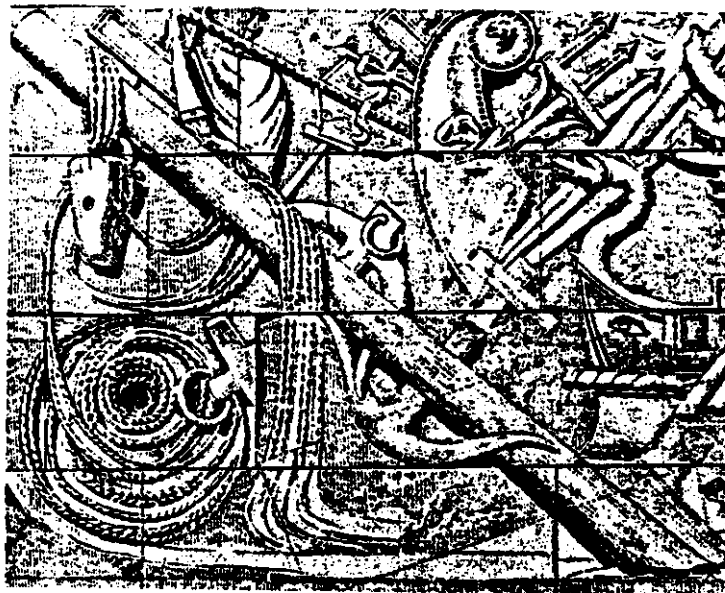

Fig. 3. Anchors and artemon appearing on the Arc d'Triomphe at Orange (adapted from A. Caristie, Monuments antiques à Orange [Paris 1956] pl. XVII).

## NOTES

1. L. Magnon, "Essai de reconstitution de l'ancre du Musée d'Archéologie de Marseille," RA 2 (1894) 220-230, and F. Moll, "The History of the Anchor," MM 13 (1927) 293-332.

2. See, for example, Magnon (supra n. 1) 229.

3. G. C. Speziale, "The Roman Anchors Found at Nemi," MM 17 (1931) 309-320.

4. F. Braemer and J. Marcade, "Céramique et pièces d'ancres trouvées en mer," BCH 77 (1953) 153.

5. S. Rocca, Beppe Michelini and Giovani Michelini, Osservazioni archeologiche sottomarine (Palermo 1962).

6. F. Benoit, "Pièces de grément et d'armement en plomb, engins et pièces décoratives trouvées en mer," Atti del III Congresso Internazionale di Archeologia Sottomarina (Barcelona 1961) 395, and G. Kapitán, "On Stone-Stocked Greek Anchors as Found in Thracia Pontica: Suggested Reconstruction of their Wooden Parts," Thracia Pontica 1 (Sofia 1982) 290-299.

7. See V. Tusa, "I rinvenimenti archeologici sottomarini nella Sicilia Nord-occidentale tra il II e III Congresso Internazionale," Atti del III Congresso Internazionale di Archeologia Sottomarina (Barcelona 1961) 263-295, as opposed to P. A. Gianfrotta, "First Elements for the Dating of Stone Anchor Stocks," IJNA 6 (1977) 285-292.

8. F. Papò, "Mare antico: Ecolle tutte insieme," MS 12 (1965) 1413-1416, begins his typology with two stone anchor types: P1 and P2. Papò's typology is compared to the author's below.

<u>Haldane</u>	<u>Papò</u>
Type I	P3
IIA	P4
IIB	P5
IIIA	P9
IIIB	P10
IIIC	P8
IVA	No equivalent
IVB	P6.

Type P7 (Papò, "Mare antico: Il 'solitario' di Acitrezza," MS 5 [1964] 153-154) is a piece of lead found at Acitrezza and identified as half an anchor stock nailed to a wooden

crossbeam placed through the anchor. Another typology is given for the "contromarre", "counterweight of the arms", involving IIA stocks and reinforcement collars. In "Mare antico: L'attrezzo fantasma," MS 8 (1965) 966-967, Papò further elaborated the anchor stock typology with the creation of type P11, the iron anchor, with r, b, or s representing Roman, Byzantine or Saracen respectively.

9. Similarly, G. C. Boon, "A Greco-Roman Anchor-Stock from North-Wales," AntJ 57 (1977) 11-13, began his typology with the stone anchor as type A. Boon's and my typologies are compared below:

<u>Haldane</u>	<u>Boon</u>
Type I	B
IIA	No equivalent
IIB	No equivalent
IIIA	C1
IIIB	C2
IIIC	C3
IVA, B	D.

Boon continues with type E, the iron anchor with a removable iron, wood, stone (sic), or lead stock.

10. M. P. Mercanti, Ancorae antiquae. Per una chronologia preliminare della ancore del Mediterraneo (Rome 1979) 63, does not give a typology but does list an alphabetical chronology. She likewise begins her chronology with A, the stone anchor. Mercanti's chronology is compared to my typology as follows:

<u>Haldane</u>	<u>Mercanti</u>
Type I	B
IIA	No equivalent
IIB	No equivalent
IIIA, B, and C	C
IVA, B	D.

Mercanti's E represents iron anchors.

11. G. Kapitän, "Der Ankerfund von Syrakus," Delphin (March 1968) 32, gives a stylistic, chronological typology for the type III stock. Equivalents between Kapitän's and my typologies are:

HaldaneKapitän

Type IIIA

- A1 Shank hole aligned with the longitudinal stock axis  
 A2 Square shank hole  
 A3 Shank hole aligned against longitudinal stock axis

IIIB

B

IIIC

- C1 Rectangular shank box exterior  
 C2 Rounded shank box exterior.

12. Strabo, The Geography 7, 3, 9. M. Murray, "A Bronze Age Anchor," MM 13 (1927) 275-277, defending herself against F. Moll, "A Bronze Age Anchor," MM 13 (1927) 183-184, maintains that votive anchors found in excavations at Malta were not thyrsus-staffs. The 800 B.C. date was accepted by H. H. Brindley, "A Bronze Age Anchor," MM 13 (1927) 5-13, but apparently not by Moll, who dates the anchor no earlier than 600 B.C. Murray goes on to suggest that Anacharsis stole the idea from the ancient Maltese and took credit for it among the Greeks. The potter's wheel and bellows, also attributed to Anacharsis, had been developed before his time.
13. Pliny, Natural History 7, 55, 209.
14. Pausanias, Description of Greece 1, 4-5.
15. Alcaeus, apud Heracl. Alleg 5. Dates for Alcaeus given by The Oxford Classical Dictionary editors N. G. L. Hammond and H. H. Scullard (New York 1976) 35, are c. 620 to 580 B.C.
16. See, for example, Homer Iliad 1, 5, 436. Stone anchors continued to be used in later times; they appear on the La Madonnina wreck near Tarentum, Italy, and are dated by A. M. McCann, "A Fourth Century B.C. Shipwreck near Taranto," Archaeology 25 (1972) 180-187, to about 350 B.C. H. Frost, "From Rope to Chain. On the Development of Anchors in the Mediterranean," MM 49 (1963) 1-20, describes the use of stone anchors by modern Levantine fishermen.
17. Magnon (supra n. 1) holds that the killick, with its many arms, became the two-armed anchor, whereas R. M. Nance, "Anchors," MM 14 (1928) 163-165, suggests that the anchor had its origins from the killick through the grapnel. F. Foerster, "Arqueologia submarina: Una

hipotesis sobre el origen del ancla de dos puntas, con cepto," CRIS 59 (1963) 8-11, on the other hand, follows Magnon's argument.

18. R. M. Nance, "Roman Anchors Found at Nemi," MM 18 (1932) 188, scraps his earlier theories of derivation from killicks and postulates that the Mediterranean received the anchor from China in view of the similarities shown between the Nemi wooden and iron anchors and Chinese anchors. J. W. van Nouhuys, "The Anchor," MM 37 (1951) 177-47, accepts the similarity as proof of Chinese derivation, as do J. R. Moriarty and N. F. Marshall: "The History and Evolution of Anchors," CEDAM International Bulletin 5, 4 (1971) 1.

19. Kapitán (supra n. 6) 290-299, suggests that the anchor developed from "bifurcating boughs" lashed to a stone anchor. Then, with the stone anchor moved into the stock position, another forked branch, or knee, was lashed opposite. H. Frost, "The Birth of the Stocked Anchor and the Maximum Size of Early Ships: Thoughts Prompted by Discoveries at Kition Bamboula, Cyprus," MM 68 (1982) 263-273, concurs with this hypothesis. Of the hypotheses presented in note 18 and here, the latter appears most probable.

20. Th. Homolle, "Comptes des hiéropes du temple d'Apollon Délián," BCH 6 (1882) 130; F. Durrbach and P. Roussel, Inscriptions de Delos (Paris 1935) v. 1, 443, 92 and v. 3, 1417, 163-165; and W. Deonna, Exploration archéologique de Délos (Paris 1938) v. 18, 198, recorded Delian inscriptions of votive anchors which Durrbach dated to after 166 B.C.

Based on this evidence, L. Casson, Ships and Seamanship in the Ancient World (Princeton 1971) 256, believes that "stone", in "an iron anchor with stone of lead," refers to the stock. "Stone," then, was the technical word for stock in the Classical period. A. Tchernia, "Direction des recherches archéologiques sous-marines," Gallia 27 (1969) 469, reports a lead-stocked iron anchor found at Ile Sainte-Marguerite, France.

21. Frost (supra n. 19) 268.

22. Gianfrotta (supra n. 7) 286, and "Le àncore votive di Sostrato di Egine e di Faillo di Crotone," La parola del passato (1975) 314, mentions a stone stock first reported by D. Adamesteanu, "Ἀρχαὶ ἄγκυραὶ ἀπὸ τῆς Μεταπόντου," Adriatica (1970) 307-324.

23. B. Liou, "Direction des recherches archéologiques sous-marines," Gallia 33 (1975) 594, and R. Calmes, "Le

gisement grec, ou étrusque, de l'anse du Dattier," CAS 5 (1975) 44-50.

24. M. Torelli, "Il santuario di Hera a Gravisca," La parola del passato (1971) 44-67, reports a stone stock dedicated to Apollo by Sostratus of Aegina and another inscribed stock at Corfu epigraphically dated to the sixth century. Both Torelli and Gianfrotta (supra n. 22) 311, and (supra n. 7) 285-291, attribute the Gravisca stock to Sostratus of Aegina described by Herodotus (The Histories IV, 152) as being "the richest of men." Gianfrotta, after L. Moretti, Inscrizioni agonistiche greche (Rome 1953) 25-64, mentions a stock at Crotona dedicated to Zeus by Phaillos, who gained fame in the Pythian games and was the only western Greek to bring his own ship to the Battle of Salamis in 480 B.C. Gianfrotta (supra n. 7) 288, and R. Pascaul Gausch, "Cepo de ancla en piedra en aguas del Mar Egeo," CRIS 151 (1976) 21, mention stocks from Aegina reported by G. Welter, "Aeginetica XIII - XXIV," AA 53 (1938) 489, fig. 15, dated to the fifth century B.C. M.-J. Chavane, Salamine de Chypre vol. VI (Paris 1975) 115, dates reused stone stocks from Cyprus to the second half of the fifth century.

25. F. Pallarés, "La primera exploracion sistemática del pecio del Sec," RStLiq 38 (1972) 287-326.

26. H. Frost, Under the Mediterranean (London 1965) 16, suggests stone stocks continued to be used as a substitute for lead. A relief of a lashed stock on a lead ingot in F. Laubenheimer-Leenhardt, "Recherches sur les lingots de cuivre et de plomb d'époque romaine dans les régions de Languedoc-Roussillon et de Provence-Corse," Revue archeologique de Narbonnaise 3rd supplement (1973) 135, causes Boon (supra n. 9) 17, to believe that the use of stone stocks continued into the first century B.C. The Nemi wooden anchor also had lashings on the stock: Speziale (supra n. 3) 315. Chavane (supra n. 24) 116, wonders if stone stocks were the most ancient or of the lowest quality.

Gianfrotta (supra n. 24) 316, (supra n. 7) 289 and "Ancore 'romane'. Nuovi materiali per lo studio dei traffici marittimi," MAAR 36 (1980) 104, disregarding the fifth-century evidence from Porticello, believes the inscriptions from Delos indicate a fourth-century changeover from stone to lead stocks. C. J. Eiseman, The Porticello Shipwreck: A Mediterranean Merchant Vessel of 415-385 BC, (unpublished dissertation, Philadelphia, 1979) 38, differing from Gianfrotta, suggests stone was the material for votive stocks, while lead was used at sea. She also writes that lead, if dedicated, was likely to have

been melted down and put to other uses, but that stone stocks, even if later used as building materials, would not change beyond recognition.

A talent of lead in the mid-fourth century B.C. cost five drachmae: IG I, 2, 374. Contrasted with a skilled laborer's daily wage of one drachma (M. Rostovtzeff, The Social and Economic History of the Hellenistic World vol. III [Oxford 1941] 1601), the stocks of the Porticello anchors alone cost about two-and-one-half-months' salary. Lead was becoming more available in the late Classical and early Hellenistic periods, but its use, due to economic restrictions, was not as prolific as it was to be in the later Roman period.

27. Diodorus of Sicily V, 35, 4-5.

28. A. Jal, Glossaire Nautique (Paris 1848) 131, believed that Diodorus spoke of blocks of wood filled with lead, whereas E. Roschach, "Ancora," Dictionnaire des antiquites grecque et romaines C.V. Daremberg and Edm. Saglio ed. (Paris 1877) 266-267, interpreted them as "tubes of wood filled with lead." Magnon (supra n. 1) 228, and W. Froehner Musée de Marseille: Catalogue des antiquités greques et romaines (Paris 1897), agree with the latter interpretation.

29. C. Torr, "Nouvelles archéologiques et correspondance," RA (1898) 441-442, refuting Froehner's "tubes", thinks anchors had neither a wood nor lead core. Moll (supra n. 1) 298-299, maintains that the Phoenecians cut off the lead from a wood core, although he is said by J.W. van Nouhuys, "Some 'Kinks' in the History of the Anchor," MM 14 (1928) 108, to agree with Roschach's "tubes". L. Jacono, "Le ancore di Nemi e i mosaici di Pompei," Il Giornale d'Italia (Nov. 15, 1930) 8, thinks that the Nemi wood-core stock confirms Diodorus' passage. R. Demangel, "Recherches sous-marins en Grèce," CRAI (1950) 323, also believes that Diodorus was speaking of type IIIC stocks, as do F. Benoit, "L'archéologie sous-marine en Provence," RStLig 18 (1952) 267-268, and Braemer and Marcade (supra n. 4) 146. R. U. Inglieri, "Notizie degli scavi: Genova - ceppo di ancora antica trovato nel porto della città," Atti della Real Accademia Nazionale dei Lincei (1957) 209-211, suggests, on the other hand, that Diodorus was speaking of type IIIB stocks.

Tusa (supra n. 7) 289, puts forth the idea that type IIA lead cores functioned as ballast; Rocca (supra n. 5) calls them lead tenons for the arm/shank junction; and F. Papò, "Mare antico: L'ancora della conguintura," MS 4 (1965) 488-489, suggests that they served as counterweights on the arms. L. M. de Urquiola, "Arqueologia submarina:

Arqueologia submarina en Vizcaya," CRIS 45 (1962) 8, accepts the argument for Roschach's "tubes". D. Owen, "Excavating a Classical Shipwreck," Archaeology 24 (1971) 126, suggests that they were part of the anchor shaft.

30. F. Benoit, "Jas d'ancre et pièces d'outillage des épaves de Provence," RStLig 21 (1955) 126, thinks type IIB lead cores may belong to a stock; P. N. Gargallo, "Anchors of Antiquity," Archaeology 14 (1961) 35, tentatively identifies type IIA cores as stocks. Type IIA cores are positively identified by Papò (supra n. 8) 1414, who imagines them lashed between boards in the stock position and relates the lead piece found at Acitrezza with Diodorus' passage. Kapitän (supra n. 11) 14-16 and 32, thinks that Diodorus referred to type IIA stocks since cutting out a type IIB core would destroy the shank. Kapitän further suggests a Black Sea origin for type IIB stocks in "Meersarchäologie in Bulgarien - Ankerfunde im Schwarzen Meer," Das Logbuch 16 (1980) 47.

31. J. P. Joncheray, "L'épave grecque, ou etrusque, de Bon Porte," CAS 5 (1976) 5-36. Due to the atypical form of the lead bar, it can be only tentatively identified as a type IIA stock.

32. Owen (supra n. 29) 126 and Eiseman (supra n. 26) 32-80.

33. G. Kapitän, "Greco-Roman Anchors and the Evidence for the One-armed Wooden Anchor in Antiquity," Marine Archaeology, D. J. Blackman ed. (London 1973) 391.

34. D. Frey, F. D. Hentschel and D. H. Keith, "Deepwater Archaeology. The Capistello Wreck Excavation, Lipari, Aeolian Islands," IJNA 7 (1978) 296.

35. A. M. Ponce i Garrido, "Descripción de algunas de las piezas halladas en el yacimiento de Isla Pedrosa," Inmersion y ciencia 14 (1975) 102.

36. Type IIB stock cores have been found at Syracuse (G. Kapitän, "Ein wichtiger Fund in Syrakus," Delphin 8 [1967] 21-22) and Sozopol, Bulgaria (B. Dimitrov, "Underwater Research Along the South Bulgarian Black Sea Coast in 1976 and 1977," IJNA 8 [1979] 75).

37. F. Benoit, "Fouilles sous-marines: L'épave du Grand Congloué a Marseille," Gallia 14th supplement (1961) 170; F. Pallarés, "Tipología y cronología preliminar de las anclas antiguas," Atti del III Congresso Internazionale di Archeologia Sottomarina (Barcelona 1961) 386-387; A. C.

Livadie, "L'épave étrusque du Cap d'Antibes," RStLig 33 (1967) 300-326; Casson (supra n. 20) 254; G. Pruvot, Épave antique étrusco-punique? au Cap d'Antibes (Antibes 1971) 37-42; and G. Kapitän, "Anchor with Wooden Remains from Haifa, and the Technique of Junction of Wooden Anchors," Sefunim 5 (1976) 38, believe the type IIIA stock found on an Etruscan wreck at Antibes to be the earliest example of a type III stock. However, Gianfrotta (supra n. 7) 287, followed by Kapitän, review of Ancorae Antiquae. Per una cronologia preliminare delle ancore del Mediterraneo, IJNA 11 (1982) 181-182, points out that in view of haphazard techniques used in the excavation of the wreck, this stock may not belong to the wreck but may instead be intrusive from a later period. A stone stock also found on the wreck was lost.

F. Fita, "Inscripciones griegas, latinas y hebras," Boletín de la Real Academia de la Historia 48 (1906) 157, records a stock with ΑΦΡΟΨΙΤΕ ΚΟΣΟΥΑ in relief and dates it, epigraphically, to the third century B.C. J. N. Svornos, "Stylides, ancores hiera, aphaस्ता, stoloi, akrostolia, embola, proembola et totems marins," JIAN (1914) 81-152, equates the Sotiera anchor published by C. Torr, Ancient Ships (Chicago 1964 ed.) 72, with the name of an Athenian and Corcyran trireme. Froehner (supra n. 28) 11, and F. Benoit, "Nouvelles et correspondance," RA (1951) 227, date a type IIIB stock to the Hellenistic period on the basis of astragals in relief on its arms. D. Mouchot, "Pièces d'ancores, organeaux et ornements de plomb antiques découverts entre Antibes et Monaco," RStLig 36 (1970) 307, puts use of type IIIB and C stocks between the fourth century B.C. and second century A.D. F. Papò, "Mare antico: Un braccio dal polso di piombo," MS 2 (1964) 143, records a stock relief as M. CARDI but reads it M CA 501, dating the stock 501 years after the founding of the Roman Republic (i.e. 252/3 B.C.). F. Benoit, "Tête coupées de l'époque grecque au moyen age," Cahiers ligures de préhistoire et d'archéologique (1959) 144-149, dates a type IIIB stock having a head in relief, found at Porquerolles, to about the second century B.C. This date is refined by Pallarés to the last quarter of the second century B.C. Kapitän (supra n. 11) 16, gives a tentative period for the use of type IIIB stocks from the Hellenistic period to the mid-first century B.C. Tusa (supra n. 7) 272-285, records several stocks with reliefs: VENERI-IOVI, dated to the Augustan period; L FULVI EUTI, dated to the Roman Republic; and ΗΡΑΚΛΗΣ, dated to the third century B.C. B. Sciarra, "Ricuperi sottomarini nel Brindisino," RStLig 32 (1966) 348, dates a type IIIB stock found near a bank of amphoras between the end of the first century B.C. and the beginning of the first century A.D.

F. P. Pallarés, "Prospecciones con la nave 'Daino' en

- aguas catalanas," RStLig 38 (1964) 298, dates the demise of the type III stock to the Roman Republic. F. H. van Doorninck, "New Evidence Concerning Development in Anchor and Hull Construction Technology during Roman and Byzantine Period," Papers from the IIIrd United States Naval Academy History Symposium, R.W. Love Jr. editor (New York 1980) 27, dates it to the end of the Roman period, while Frost (supra n. 26) 32 dates it to the Byzantine period. According to Boon (supra n. 9) 17, type III stocks become obsolete in the first century A.D.
38. N. Lamboglia, "La campagna 1963 sul relitto di Punta Scaletta all'Isola di Giannutri," RStLig 30 (1964) 230-357, reports four wooden and three iron anchors recovered from the wreck. F. Benoit, "Épaves de la cote de Provence: typologie des amphores," Gallia 14 (1956) 28, recovered two type IIIB stocks from the wreck at Grand Congloué, initially dated between 220 and 130 B.C. Two wrecks were excavated as one, however, and secure dating of the stocks is impossible.
39. Benoit (supra n. 38) 26-27.
40. F. Carraze, "L'ancre de miséricordé dans la marine antique," Archeologia 61 (1973) 15, first dates Grand Ribaud between 160 and 120 B.C., but later refines the date to 130 B.C. ("Note on two decorated lead anchor stocks," IJNA 3 [1974] 153-157) and dates the Jeune-Garde wreck to 140 B.C.
41. F. Foerster and R. Pascaul, "La nave romana de 'Sa Nau Perduda'," RStLig 36 (1970) 273-306.
42. G. Charlin, J.-M. Gasend, and R. Lequément, "L'épave antique de la baie de Cavalière," Archaeonautica 2 (1978) 9-93.
43. F. Benoit (supra n. 29) 263-264.
44. A. Merlin, "Lingots et ancres trouvés en mer près Mahdia (Tunisie)," Melanges Cagnat 32 (1912) 383-397.
45. W. Piepers, "Tiele römischer Shiffsanker von Niederrhein," BonnJbb 174 (1974) 561-566. K. Korber, "Die in den Jahren 1914 und 1915 gefunden en römischen Inschriften und Bildwerke im Altertumsmuseum der Stadt Mainz," MZ 10 (1915) 115, details a type IIIB stock inscribed with LEG XVI, the sixteenth legion, stationed in Gaul in the first year of Claudius' reign. Fita (supra n. 37) 160 traces the relief, L Aegilli L. L. Maxsumi, on a type III stock to lead mines near Cartagena in the Augustan

period.

46. A. Bouscaras, "Recherches sous-marines au large d'Agde (1951-53)," RStLig 20 (1954) 53, wonders whether the oval shank box on type IIIC stocks is a common or decadent form. G. Kapitän, "Ancient Anchors and Lead Plummets," Sefunim 3 (1969-71) 51, suggests that because the wood core stock is more technically advanced than lead-tenoned stocks, the former is a late form. He also says that type IIIC represents the final stage of development; the rounded exterior of the shank box is a technical improvement on earlier rectangular shank boxes: "Exploration at Cape Graziano, Filicudi, Aeolian Islands, 1977," IJNA 7 (1978) 269-277. Kapitän (supra n. 37) 183, stresses the need for a typological/epigraphical study of anchor stock development based on stock arm ends, the outside shape of the shank box and other features. Preliminary work in this area by the author yielded conflicting results. Oval shank boxes actually appear earlier than rectangular, and no pattern of development can be determined for the arm ends of stocks. However, studies of anchor stock manufacture have yielded positive results.

47. J. P. Joncheray, "L'épave 'C' de la Chrétienne," CAS 1st supplement (1975) 104-108. The three stocks recovered from the wreck have rounded shank box exteriors.

48. Speziale (supra n. 3) 315. H. Comfort, "Sigillata from the Ships at Lake Nemi," Rei cretariae romanae fautores Acta II (1959) 5-12, dates pottery found near or under the anchors between A.D. 60-65. B. Sciarra (supra n. 37) 342, dates a type IIIC stock found among fragments of Dressel 19 amphoras between the third and fourth centuries A.D. Radiocarbon studies on the core of a type IIIC stock yielded dates of 80 +/- 100 B.C. and A.D. 0 +/- 50: Kapitän (supra n. 46) 276.

Both type IIIB and IIIC stocks were recovered from the wreck at Cape Graziano and dated by Pallarés between 140 and 130 B.C. (supra n. 37) 388-389. Kapitän (supra n. 37) 182-183, calls the provenance of these stocks into question.

49. If one accepts a sixth-century date for the type IIIA stock from Antibes, it stands alone, five centuries before the next earliest-dated type IIIA stock.

50. Tusa first records this inscription as ΑΗΕΝΟΪΑΚΣ ([supra n. 7] 274), and then as ΑΗΕΝΟβΑΛβ ("Ancore antiche nel Museo di Palermo," Marine Archaeology, D. J. Blackman editor [London 1973] 424). P. A. Gianfrotta and P. Pomey, Archeologia subacquea (Milan 1980) 309, clarify

the background of this stock.

51. Maltini-Soliani first published the inscription as CA...QUE ULLI PROCUL: "Un raro ceppo ancora da decifrare," MS 8/9 (1967) 786.

52. P. A. Gianfrotta, "Un ceppo di C. Aquilo Proculo tra i rinvenimenti archeologici sottomarini a Punta Licosia nel Cilento," Forma Maris Antiqui 1973-1974 10 (Bordighera 1980) 2-35, finds many Proculi, including C. A. Proculus.

53. Lucian, A True Story 1, 42, makes a pun on the word skulinais, "wood", with nalinais, "glass"; Zeus Rants 47, making everything backward on a mismanaged ship, describes figureheads of lead and anchors of gold.

54. Fita (supra n. 37) 160, derives Lucius Valerius Lupus from the relief but finds no correlation for the name.

55. A. Degrassi, I Fasti Consulari dell'Impero Romano (Rome 1952) 64, records L. Virius Lupus and L. Marius Maximus as consuls in A.D. 232. Although the maritime mercantile practice was frowned on in ancient Rome, many consuls were shipowners (J. H. D'Arms, Commerce and Social Standing in Ancient Rome (Cambridge Massachusetts 1981) 149-162). The Ahenobarbus, Proculus and Lupus stocks give further testimony that consuls and shipowners were often one and the same.

Other reliefs that may yield valuable correlations are T. Aeli recorded by Gargallo (supra n. 30) 33, and related by Boon (supra n. 9) 17, to a military tribune in 178 B.C.; and a dubious inscription Il Antoni Felix Ezero found on two stocks, one in Meloria, Italy, the other in Hvar, Yugoslavia, and recorded by F. Papò, "Mare antico: I gemelli di piombo," MS 4 (1966) 393. Two other stocks inscribed with Lucius Ferranius Celer, recovered on the Tyrrhenian coast, were described by Gianfrotta and Pomey (supra n. 50) 309, and were epigraphically dated by Gianfrotta (supra n. 26) 111, to the first century A.D.

56. Lamboglia (supra n. 38) 253.

57. H. Frost, "Discovery of a Punic Ship," IJNA 1 (1972) 114, associates an anchor without its removable stock, found in the harbor of Mozia, with Punic warships. Boon (supra n. 9) 17-18, agrees with this dating method and further suggests that the anchors portrayed on the Arc d'Orange (A. Caristie Monuments antiques à Orange (Paris 1856) 16-17) also have removable stocks.

Frost (supra n. 26) 20, earlier suggested that

removable stocks originated with the Venetii as evidenced by the first century A.D. iron anchor from Bulbury, England: B. Cunliffe, "The Late Iron Age Metalwork from Bulbury, Dorset," AntJ 52 (1972) 300, fig. 5. F. Papò, "Mare antico: La fabbrica delle anfore," MS 9 (1965) 1078, records a removable stock inscribed with P. Veeio or Paceeto but gives no date.

Kapitän (supra n. 46) 52, among many others, dates removable stocks to the Hellenistic period based on the astragals often shown in relief. A type IVB stock was reportedly recovered from the Antikythera wreck dated to 65 BC; Kapitän, (supra n. 30) 46, and D. J. de Solla Price, "An Ancient Greek Computer," Scientific American (June 1959) 60-67. Unfortunately, dating evidence for type IVB stocks is scantier than for type IVA stocks.

58. The Histories IX, 74. Magnon (supra n. 1) 224, suggests wood was stronger than iron and was used predominately, while Moll (supra n. 1) 316, suggests two lines of development, one for iron, the other for stone. Nance (supra n. 18) 188, differing slightly from Magnon, believes wood was proper anchor material and was only reinforced by iron. V. Cosma, "Anchors from Tomis," IJNA 2 (1973) 239-240, reconstructs a wooden anchor strengthened by iron strips. Van Nouhuys (supra n. 18) 43-44, suggests iron anchors were covered with wood to prevent their sinking into muddy seabottoms.

59. Gianfrotta and Pomey (supra n. 50) 307.

60. Frey, Hentschel and Keith (supra n. 34) 290. The iron anchor was replaced on the site as its association with the wreck is uncertain.

61. Athanaeus, The Deipnosophists, 208.

62. Ponce i Garrido (supra n. 35) 101. Speziale (supra n. 39) 309-320. J. P. Joncheray, "Contribution a l'étude de l'épave Dramont D dite 'des pelvis'," CAS 2 (1973) 9-49. A lead stock was reported on the wreck but lost.

63. J. P. Joncheray, "Une épave du Bas Empire: Dramont F," CAS 4 (1975) 91-140. Other iron anchors include a broken, second-century B.C. anchor from La Ciotat (F. Benoit, "Nouvelles épaves de Provence," Gallia 18 (1960) 24-25, fig. 9), which Moriarty and Marshall (supra n. 18) fig. 9C, wrongly call short-shanked, bronze and possibly Phoenician, and numerous anchors dated to A.D. 79 from Pompeii (O. Elia, "Il portico dei Triclini del Pagus Maritimus di Pompei," BdA 46 [1961] 210, fig. 18). A second-century A.D. anchor from Cervia (M. Bonino,

"Ricerca sulla nave romana di Cervia," Atti del III Congresso Internazionale di Archeologia Sottomarina (Barcelona 1961) 320-321 fig. 5) and a third century A.D. anchor from Villepey (F. Benoit, "Nouvelles epaves de Provence (II)," Gallia 18 (1960) 49, fig. 16) have also been reported.

64. Sources of lead are given by R. H. Brill and J. M. Wampler, "Isotope Studies of Ancient Lead," AJA 81 (1967) 63-77, and R. H. Brill, I. L. Barnes and B. Adams, "Lead Isotopes in some Ancient Egyptian Objects," Recent Advances in Science and Technology of Materials vol. 3, A. Bishay editor (New York 1971) 9-27.

65. Van Doorninck (supra n. 37) 27, suggests that wooden anchors became obsolete during the early fourth century. Without a comprehensive look at iron anchor construction, it is difficult to compare the strength of their construction to wooden anchors. Speziale (supra n. 3) 317, counted four forge-welded together in the iron anchor from Nemi; the illustration of the Cervia anchor suggests a similar construction (Bonino [supra n. 63] 320). Van Doorninck, on the other hand, has observed from seven to fourteen blooms in medieval anchors: "The Fabrication of Some Medieval Iron Anchors at the Bodrum Museum in Turkey," Proceedings of the Thirteenth Conference on Underwater Archaeology (in press).

66. Brindley (supra n. 12) 7, after Torr, suggests that coins from Apollonia Pontica depict mushroom anchors and prove Torr's hypothesis that weights were placed between the arms: (supra n. 37) 70.

67. Moll, differing from Brindley, says the Apollonia Pontica anchors were not mushroom shaped and postulates that they were cast bronze: (supra n. 18) 39.

68. Van Nouhuys (supra n. 18) 39.

69. Magnon (supra n. 1) 226, and Benoit (supra n. 36) 225, attempting to understand how the lead tenon of type IIIB stocks passed through the shank, fit the shanks to the stock rather than vice-versa. Despite the evidence for single-piece shanks shown by the Nemi anchor (Speziale [supra n. 3] 315), Benoit (supra n. 29) 269, believed two shank halves sandwiched a strip of wood that compensated for the intervening space caused by the lead tenon. When a single-piece shank was discovered by G. Barnier in 1954 ("Découvertes d'outils antiques au fond de la mer," Atti del II Congresso Internazionale di Archeologia Sottomarina [Albenga 1958] 305-315), Benoit corrected his error and

determined that type III stocks were poured directly on shanks: (supra n. 30) 119. A. Merlin had already reached this conclusion in 1912: (supra n. 44) 304-305. Foerster persisted in the belief that type III stocks were poured separately and later mounted: "El problema de la fijación de los cepos en las anclas que se utilizaban en la antigüedad," CRIS 42 (1962) 29-30. However, Foerster later agreed that type III stocks were poured directly on the shank, but placed a prefabricated lead bar through the shank for type IIIB stocks: "Arqueología submarina: El problema de la confección de las anclas antiguas con cepo de plomo," CRIS 54 (1963) 4-7. Gargallo (supra n. 30) 32, suggested that type IIIC stocks were made separately and mounted by placing the stock on the shank and inserting the wooden core through both.

70. Supra n. 6, 290-299. Previously, Welter (supra n. 24) 491, and S. Picozzi, "L'archeologo: Tre buchi in una pietra," Il subaqueo 9 (1974) 72-75, saw stone stocks as weight anchors; F. Papò, "Mare antico: L'arrato del bifolco-marinaio," MS 12 (1963) 125-126, and F. Foerster, "Arrainguras en el Mediterraneo? Y por que no?" CRIS 137 (1972) 24-25, as a weight over the arms of a killiick.

71. Laubenheimer-Leenhardt (supra n. 26) 135, records a lead ingot with an impression of a cross-bound stock; however, in view of the first century B.C. date, it is difficult to associate this representation with stone-stocked anchors.

72. Kapitän (supra n. 6) 295, does not suggest crotch replacement.

73. See supra n. 69.

74. Although W. B. Lord, "Anchors," The Nautical Magazine (March 1901) 136, suggested *lignum vitae*, ironwood, or ebony, and Donnadieu, "Decouverte d'une ancre antique," Bulletin officiel du Club Alpin Sous-Marin (1949), postulated Lebanese cedar was used for wooden anchors, remains of an oaken shank are reported by E. Ripoll Perello, "Notas de arqueología de Cataluna y Balaeres," Ampurias 24 (1962) 312, and oaken shanks and arms, by Speziale (supra n. 3) 319, and Piepers (supra n. 45) 562.

Chestnut cores of type IIIC stocks have been reported by F. Moll, "Ein Bleianker," AA 14 (1929) 267, and Speziale (supra n. 3) 319.

75. Over 70 percent of the stocks measured by the author exhibit this dimension (Appendix 1). For as long as type

II-, III- and IV- stocked anchors were made, the use of rectangular-section strength was strictly adhered to. A rectangular beam is stronger on its narrow side than on its broad side: V. Cosma, "Anchors from Tomis 2," IJNA 4 (1975) 25. Accordingly, anchor arms were set on the narrow side of the shank and rectangular lead tenons, wood cores and stock arm large cross-sectional dimension were aligned with the longitudinal shank axis. In every aspect, wooden anchors were designed to be as strong as possible.

76. Among others, Cosma (supra n. 75) 23, and Boon (supra n. 9) 14, have reconstructed the shaft length of anchors based on the evidence from Nemi and Chrétienne C; however, one intact anchor and one intact arm of another is not conclusive evidence.

77. Brindley (supra n. 12) 8, would make this bulge a point for securing a stock.

78. Frost (supra n. 57) 114-116, and G. Kapitän, "Rinvenuta nel mare dell'Isola Lunga un'ancora antica a ceppo smontabile," Sicilia archeologia 16 (1972) 13-22. Kapitän (supra n. 37) 34-36, calls the Nemi anchor "inferior workmanship" due to its lack of a hook joint. The dissimilarity between the Nemi and Chrétienne C anchors may be the difference between mooring and working anchors. Mercanti (supra n. 10) 29, wrongly states that the arm joints of Nemi and Chrétienne C are identical

79. Speziale (supra n. 3) 319, believes these crowns were used for hauling the anchor inboard after raising. Joncheray, however, cannot discern any evidence of a cord on the Chrétienne C crown: "Archeologie & plongee: Un exemple d'ancre en bois à jas de plomb," L'aventure sous-marine 92 (1973) 22.

80. Kapitän (supra n. 37) 36, suggests tenons protruded to facilitate removal for repair of the anchor.

81. Pindar (Pythian Odes IV, 24) speaks of bronze "teeth", and Livy (Book XXXVII, 30, 9-10) describes iron "teeth". Bronze "teeth" were recovered from the Porticello wreck (Eiseman [supra n. 26] 34-35, fig. 2.34) and iron "teeth" from Nemi (Speziale [supra n. 3] 319), and the Chrétienne C wreck (Joncheray [supra n. 47] fig. 51).

82. "Teeth" were nailed through the cone (Eiseman [supra n. 26] 34) or through fillets extending from the cones (Speziale [supra n. 3] 319).

83. Arm angles based on reinforcement collars are given

by Eiseman (supra n. 26) 39, and Cosma (supra n. 58) 235 and (supra n. 75) 22-23.

84. Iron anchors initially imitated V-shaped wooden-anchor arms and later progressed through lunate and cruciform until the arms met the shank at an obtuse Y-angle in the medieval period: van Doorninck (supra n. 37) 27 and (supra n. 65).

85. F. Papò, "Mare antico: Un ceppo in maschera," MS 1 (1965) 140-141, and Cosma (supra n. 58) 236, give 30 degrees for the Nemi anchor's arm angle. S. Picozzi, "Vita di un àncora," Il subacqueo 2 (1973) 74-76; F. Papò, "Mare antico: L'ancora che guida al relitto," MS 11 (1963) 119-120; Frost (supra n. 26) 55; and J. Bravo, "Arqueologia submarina: Anclas romanas," CRIS 70 (1964) 9, suggest an arm angle of 45 degrees or 90 degrees overall, when, in actuality, the total of both arm angles was closer to 60 degrees.

86. Beveling increased ease of handling (Kapitän [supra n. 46] 51) and reduced splitting.

87. Type III stocks exhibit shanks with any combination ranging from no to all edges having complete or partial bevels.

88. F. Papò, "Mare antico: Il ceppo ei suoi compagni," MS 3 (1964) 142-142, originated the fallacious term "contromarre" or "counterweight of the arms" on the basis of an incorrect hypothesis that reinforcement collars acted as counterweights, being too weak to reinforce the arms. Unfortunately, this hypothesis has been followed by Bravo (supra n. 85) 9, Kapitän (supra n. 33) 387, and Gianfrotta (supra n. 52) 25. Frost (supra n. 26) 56, Casson (supra n. 20) 254, Piepers (supra n. 45) 565, Mercanti (supra n. 10) 26, Carraze (supra n. 40) 15, and C. G. Rivera and D.L. de la Orden, "Elementos de ancla antiguas del Museo de Cadiz," Boletin del Museo de Cadiz 2 (1979-1980) 72, believe reinforcement collars were integral, structural elements of anchors.

89. Picozzi (supra n. 85) 76, Boon (supra n. 9) 13, and Kapitän (supra n. 37) 181, propose that these collars reinforced wooden-anchor arms.

Although Cosma (supra n. 75) 23, and Picozzi (supra n. 85) 74, believe reinforcement collars were poured separately and mounted on anchors trimmed to receive them, evidence presented by Kapitän and by the collars themselves suggests that they were poured directly onto anchors: "New Evidence of Ancient Anchors," Archaeology 24 (1971) 53.

Contraction holes between arm and shank, formed as the lead cooled, indicate the pour's location.

90. Eiseman (supra n. 26) fig. 2.47, among many others, records reinforcement collars with angular junctions. A reinforcement collar with rounded arm/shank junctions is reported by R. Pascual Gausch and L. Esteva, "Materiales de procedencia submarina depositados en el Museo Municipal de Feliu de Guixols," Atti del III Congresso Internazionale de Archeologia Sottomarina (Barcelona 1961) Fig. 5. The anchors recorded by Caristie (supra n. 57) 16-17, have rounded arm/shank junctions, but one cannot accurately determine whether the anchors are wooden or iron.

91. Because Delian inscriptions specified wooden anchors with two arms, a distinction between these and one-armed anchors must have been necessary: Durrbach (supra n. 20) 59. In an Egyptian inventory accompanying the lease of a boat, three iron anchors are listed, two with two arms, the other with one: Greek Papyri 1714, 32.

92. Kapitän (supra n. 39) 387-393. Two-holed reinforcement collars found in Germany have been associated with two-armed anchors: Piepers (supra n. 45) 565, fig. 1. Lead bars connect three lead tenons that passed through the arms and shank.

93. Measured from the inner surface of the arm, the angle is 80 degrees; from the outer surface, 40 degrees.

94. Kapitän (supra n. 33) 393.

95. A collar with two holes, identified by F. Papò as a reinforcement collar for a one-armed anchor ("Mare antico: La fabbrica di Aquileia," MS 12 [1966] 1219) was later identified by Kapitän (supra n. 78) 19, as a reinforcement collar for the head of a removable-stocked anchor similar to that found at Isola Lunga. J. Bravo has published a reinforcement collar with cones of lead where holes were drilled into the arms before pouring: Ancorae Antiquae (Ceuta 1976) 18.

96. J. Bravo, "Arqueologia submarina: Algo más sobre el ancla llamada romana," CRIS 57 (1963) 5.

97. Kapitän reconstructs an anchor-head reinforcement collar from Sardinia as a reinforcement for anchor arms: "Bemerkungen über einen antiken Holzanker und zum Thema 'Archäologische Funde'," Delphin 6 (August 1960) 969. However, Papò, "Mare antico: Due anfore imperiali," MS 7 (1969) 816, reconstructs a similar collar from Taormina,

Sicily, as a reinforcement for the anchor head, although he assigns it to type P11, originally his designation for iron anchors. Other head-reinforcing collars were recovered at Ceuta (Bravo [supra n. 96] 5) and Cadiz (Rivera and de la Orden [supra n. 88] 71-72). Dimensions of removable stocks closely approximate the measurements of the Sardinia and Ceuta collar holes.

98. Evidence of wood grain was found on type IIA cores from Kyrenia and a type IIB core from Syracuse: Kapitän (supra n. 33) 390-391 and (supra n. 11) 25.

99. J. Granier, "Trouvailles fortuites et 'glanes' archéologiques sur le littoral gardois," RStLig 31 (1965) 293; A. Bouscaras, "Recherches sous-marines-été 1967. Épave des bronzes," BSAS, 3 (1967) 16-17; and Kapitän (supra n. 11) 15.

100. Bravo (supra n. 95) 9, Eiseman (supra n. 26) 65, and M. B. Soriano, "Los hallazagos arqueologicos submarinos ingresados en el Museo Arqueologico de Tarragona," Boletín arqueológico de Tarragona 69-70 (1969-1970) Fig. 6.

101. G. Kapitän, "Un hallazgo arqueologico importante en Siracusa," CRIS 120 (1969) 26-31.

102. Kapitän (supra n. 11) 15 and (supra n. 101) 28, and Eiseman (supra n. 26) 65.

103. Kapitän (supra n. 45) 273, and Dimitrov (supra n. 36) 75.

104. G. Kapitan, "A New Type of Anchor Stock," Archaeology 21 (1968) 63, and Dimitrov (supra n. 36) 75.

105. Kapitän (supra n. 101) 29. Lead contraction holes on the narrow side of type II cores reveal that this side was facing up when the lead was poured. Thus if the anchor and its stock were upside down during the pour, the narrow side was the underside of the stock.

106. Experiments by Bravo on the effects of molten lead on wood yielded only slight scorching: (supra n. 85) 9.

107. Lead cores recovered from the Porticello wreck weighed 74, 112, 94 and 123 kilograms: Eiseman (supra n. 26) 34, and two found at Cape Graziano weighed about 70 and 80 kg: Kapitän (supra n. 46) 272.

108. Kapitän (supra n. 33) 391.

109. Eiseman (supra n. 26) 37.

110. For example, the Roman L. Plani. L. F. ingot published by Laubenheimer-Leenhardt (supra n. 26) 135, weighs 32.5 kg, which, utilizing a Roman pound of 327.45 grams (Hammond and Scullard [supra n. 15] 1138), is almost exactly 100 Roman pounds.

111. Infra n. 133.

112. Moriarty and Marshall (supra n. 18) 5, and Boon (supra n. 9) 11, believe type III stocks were cast in wooden molds. Van Nouhuys, on the other hand, believes type IIIC wood cores were used to strengthen wax used in a lost wax method of casting lead stocks: (supra n. 18) 41. Speziale (supra n. 3) 319, Benoit (supra n. 30) 122, Bravo (supra n. 85) 10, and Cosma (supra n. 75) 25-26, correctly suggest stocks were poured in open molds of beaten earth, sand or clayey-sand. A type IIIB stock in Sagunto exhibits a lump on an upper edge: evidence for a clayey-sand mold with a fallen edge. The face of one type IIIB stock arm in Nice exhibits creases that may have been formed by a paddle used to smooth mold walls.

Papò (supra n. 85) 140-141, expounds on a question first asked by Pallarés (supra n. 37) 9-10: whether bent stocks were products of torsion on the seabed or created in curved molds. Papò believes stocks were poured straight and later bent for stowing on board. Sciarra (supra n. 37) 343, concurs with Papò's hypothesis. Maia, however, believes stocks were bent by dragging on the seabottom: "Cepos de chumbo de âncoras romanas encontrados ao largo de Sesimbra," Setúbal arqueologia 1 (1975) 177-180. Boon attributes the "crescentic profile" of the type IIIB Porth Felen stock to premature removal from the mold: (supra n. 9) 10. Whether a stock was curved before or after its removal from the mold can be determined by its plane of torsion relative to the pour surface. If a stock is bent in a plane parallel to the longitudinal shank axis, bending occurred after manufacture, as a stock bent in this manner would be impossible to pour: no level surface is presented. Bends in a plane perpendicular to the longitudinal stock axis could have been created in a mold, but probably are not, as no consistent pattern of bending occurs. Bent stocks can be attributed to the rigors of use. Boon's stock, if prematurely removed, would exhibit a "crescentic profile" opposite the one it has.

113. Cosma (supra n. 75) 25-26.

114. R. Pascaul Gausch, "Cepo de ancla romanos recuperados frente a Blanes (Barcelona)," Zephyrus 10

(1959) 176, suggests reliefs were molded first and later fixed to stocks. R. F. Tylecote, however, has produced reliefs by casting lead on an imprinted sand bed: "Welding Technology: The Archaeology of Metal Fabrication in the British Isles," British Welding Journal (1962) 517. F. Papò reports an astragal left in the mold and cast into the stock: "Mare antico: Colpo da otto sulla via delle ancore," MS 11 (1964) 170-171. J. Bravo, "Un cepo de ancla decorado en aguas de Ceuta," RStLig 30 (1964) 310, publishes a stock whose astragals partly stand free of the stock; the impressions could only have been made before the lead was poured.

115. Examples of these patterns are recorded by Benoit (supra n. 63) 55, Soriano (supra n. 100) 12, fig. 4, and Bravo (supra n. 114) 310, respectively.

116. Values for each side given by G. Rohlf's are 1, 3, 4 and 6. The "Venus" throw had a value of 14, while the lowest, or "dog" throw, had a value of 4: Antikes Knöchelspiel im Einstigen Grossgriechenland (Tübingen 1963) 13-17.

117. Rivera (supra n. 88) 72.

118. F. Benoit, "Dodécaèdre d'Arles et anneau de Vichy," Ogam 9 (1957) 107.

119. Used in this fashion, astragals represent the power of sympathetic magic.

120. See Benoit (supra n. 36) 226 and (supra n. 37) 146, for severed heads; Gianfrotta (supra n. 26) Fig. 8, for scallop shells; P. Fiori, "Le mouillage antique du Cap Gros," CAS 3 (1974) Plate 4, for scallop shells and dolphins; Carraze (supra n. 40) 155, and Ripoll Perello (supra n. 74) 286, for dolphins; and Soriano (supra n. 100) 13, for tritons. Another type IIIB stock with tritons may be seen in St. Tropez. Benoit has identified the severed heads as the head of Medusa which Perseus used to slay the sea monster that threatened Philistia: R. Graves, The Greek Myths vol. 1 (Baltimore 1955). Aphrodite's birth is credited to both sea foam and a scallop shell. The dolphin may be attributed to both Aphrodite and Poseidon; its rescue of Apollo after a shipwreck earned it the distinction as the savior of sailors. Tritons, as sea creatures, are attributed to Poseidon. Other motifs on anchor stocks include a staff of Hermes (Soriano [supra n. 100] 73), a bipedal lion (Carraze [supra n. 49] 4), something identified as a miner's hammer (Perello [supra n. 74] 286), columns (Pascual Gausch [supra n. 114] 179),

and a lamp (Tusa [supra n. 59] 426-427, and Gianfrotta [supra n. 26] Fig. 10).

121. Stocks bearing the names of epithets of Aphrodite/Venus and Zeus/Jove are recorded in Palermo by Tusa (supra n. 50) 427-428, in Cartagena by Fita (supra n. 37) 72, and in Izmir by M. Schlumberger, "Séance du 11 Février," Societe national des antiquaries de France: Bulletin 554 (1880) 85. A stock with Heracles in relief is reported in Palermo by Tusa (supra n. 50) 431. Gianfrotta, (supra n. 26) 109-110, describes stocks from Calabria and Cagliari with reliefs of Hera and Isis. Divinities sacred to seamen were Artemis, Heracles, Athena, Poseidon, Apollo, Hera, Aphrodite and Hermes: W. H. D. Rouse, Greek Votive Offerings. An Essay in the History of Greek Religion (Cambridge 1902) 228-229. With the exclusion of Artemis and the addition of Zeus, names or attributes of each deity are found on anchor stocks. The inscription that best represents the desire for a firm anchorage is me kine tode, "don't move this", carved into a stone stock from Aegina: Welter (supra n. 24) Figs. 14 and 15.

122. Stocks with ring reliefs have been reported from Ceuta (J. Bravo Perez and J. Bravo Soto, "Vestigios del pasado de Ceuta," Immersion y ciencia 4 [1972] 5-39), Tarragona (Soriano [supra n. 100] 11), Santa Maria del Castellabate (Gianfrotta [supra n. 52] 23) and Blanes (F. Foerster Laures, "Un cepo de ancla romana, con decoración, frente a Taimiru," CRIS 152 [1976] 18). Bravo first interpreted the rings as crowns or wreaths, and later as circles of immortality: (supra n. 115) 311.

123. Infra n. 155.

124. Supra n. 55. Gianfrotta believes that the Hera and Isis reliefs and a stock with Ceres in relief refer to ships' names: (supra n. 26) 110. In reference to different stock reliefs, others have suggested similar correlations. Because ships were often given divine names (Casson [supra n. 20] 439-441), it is difficult to discern whether the stock relief refers to a ship or is an appeal to a god.

Often, these inscriptions read backward: an inscription reading left to right in a mold will read right to left on a cast stock. Retrograde inscriptions were common among the Greeks, but not the Romans. Although F. Papò ("Mare antico: Il poker dei solitari," MS 7 [1965] 854), among others, attributes this to haste and ignorance, in view of the often meticulous care taken in inscribing the reliefs, one can consider backward Latin, and perhaps Greek, inscriptions as, simply, mistakes.

125. Gianfrotta (supra n. 26) Fig. 13.

126. Most tenon mortises were rectangular with a longitudinal axis perpendicular to the length of the shank. When a shank was placed into a mold, the mortise could be situated anywhere between the top and bottom of the shank box. A lead tenon in a stock from the Mahdia wreck was located at the top of the mold (i.e. at the under face of the stock). Boon has suggested green or wetted wood was used for anchor shanks because of the high temperature of molten lead. Neither hypothesis is likely due to the obdurate nature of green oak and explosions that would occur when hot lead came in contact with water.

127. Joncherary (supra n. 47) 108. G.C. Boon, "A Graeco-Roman Anchor-Stock from North Wales," Archaeologia atlantica 1.2 (1976) 196, believes it was necessary to embed type IIIC cores in lead before pouring, but, as Kapitän (supra n. 37) 181, points out, lead often intruded in gaps between the shank and core in a haphazard manner that does not suggest embedding.

128. Contraction holes frequently indicate pouring next to the shank; holes also occur at the stock arm ends. G. C. Whittick determined that shallow cooling striations occur in lead poured below 450-500 degrees centigrade: "The Casting Technique of Romano-British Lead Ingots," JRS (1961) 106. Bravo misinterprets striations on astragals and believes them to exhibit wood grain: "Cepos de anclas romanas con relieve," CRIS 86 (1966) 2-4. An example of lead poured below 450 degrees centigrade is recorded by Gianfrotta (supra n. 26) fig. 13. In view of the smooth faces often exhibited by type III stocks, the lead temperature at pouring was probably slightly higher.

129. Layering occurs if lead pouring is interrupted: Whittick (supra n. 128) 107. Only two stocks studied by the author exhibit signs of intermittent pouring, one in Antibes, the other in St. Tropez. Soriano (supra n. 100) 11, records a stock made in three pours.

130. This is a common occurrence on all stocks: Whittick (supra n. 128) 178. A trench on a type IIIB stock in Nice was filled with lead after the stock cooled.

131. Pascaul Gausch (supra n. 114) 177.

132. Piepers (supra n. 45) 563, and Körber (supra n. 45) 115.

133. Gianfrotta (supra n. 52) 2-35, records stocks bearing the inscription  $\Xi\text{TR}$  and Roman numerical equivalents of 5, 39, 211, 219, 235, 302, 319, 325 and 335, and concludes that they may indicate weight. Papò, who first thought numbered stocks indicated date, later suggests that they indicate arsenal numbers: "Mare antico: Le anfore del Mar Nero," MS 5 (1969) 566-567. A stock described by Papò is inscribed with CCCXLI and weighs about 100 kg, which, divided by a Roman pound of 327.45 grams, equals 305 Roman pounds. Evidently, after the amount of lead used in the pour was inscribed on the stock after pouring. With exact weight figures, more exact correlations may appear. A weight inscription may also occur on the iron anchor from Nemi: Speziale (supra n. 3) Plate 3.

134. Speziale (supra n. 39) 319.

135. Kapitän (supra n. 78) 16. Benoit (supra n. 38) 30, reports a ring hole in the head of the type IIIB Antheor A shank. A hawser or rope ring may have passed through the hole.

136. Gianfrotta (supra n. 26) fig. 2, and Papò (supra n. 57) 1078. There is a type IVA stock in Brindisi with IOVIA in relief.

137. Modern authors differ on how the two type IVA stock holes were used. All agree, however, that one was used to secure the stock, and the other for retrieval of the stock in case it came loose. Cosma (supra n. 58) 238-239, reports remains of hemp rope in a stop pin hole.

138. Tusa (supra n. 7) 283.

139. Evidence for ship and anchor stock size at Cavalière is found in Charlin, Gassend and Lequément (supra n. 41) 54, 79 and 80; Kyrenia in Kapitän (supra n. 33) 391 and J. R. Steffy (personal communication); Capistello in Frey, Hentschel and Keith (supra n. 33) 296; Chrétienne C in Joncheray (supra n. 47) 107; Sa Nao Perduda in Foerster and Pascaul (supra n. 41) 284-285; Porticello in Owen (supra n. 129) 126 and Eiseman (supra n. 26) 34; Punta Scalleta in Lamboglia (supra n. 38) 252-253 and Mercanti (supra n. 10) 26; Mahdia in Casson (supra n. 20) 190 and 255, and Merlin (supra n. 449) 391-396. Tonnages not given by sources were determined by length x beam x .5 beam divided by 94.

In the third quarter of the fourth century, Athenian warships were outfitted with two anchors each: CIA vol. II, 807, col. c, 66-102; 808, col. d, 119-151; 809, col. e,

75-110; 811, col. c, 11-32. Two anchors are reported from the Nemi barges, and five other unexcavated hawsers may have led to more anchors: Speziale (supra n. 3) 312. Three anchors are recorded on a river boat in Egypt: Greek Papyri (supra n. 91) 164. Because anchors were to be cast out of the bow of St. Paul's ship (infra n. 144) after four were cast out of the stern, one may assume at least six anchors were carried on board. Moll (supra n. 1) 304, based on the Athenian Naval Records, believes ships carried two to four anchors. Sciarra (supra n. 37) 341, suggests five to six anchors were used while Frost (supra n. 26) 57-58, proposes eight to twelve. Depending on the size or type of ship, each proposal can be considered correct.

140. Athanaeus, The Diepnsophists, 208 and Casson (supra n. 20) 185-186.

141. Ships on the scale of the Siracusia may have used abnormally large anchors similar to the 3.6 meter long, ca. 1800 kg (two ton) Qawra Point anchor stock found at Malta: Zammit, Report on the Working of the Museum Department for the Year 1963, (Malta 1963) 7 and fig. 6. Infra n. 156.

142. A. Merlin and L. Poinssot, "Cratères et candélabres de marbre trouves en mer pres de Mahdia," Notes & documents publiés par la Direction des Antiquités et Arts IX (Tunis 1930) 16.

143. Plutarch, Lives: Caius Marcius Coriolanus XXXII; Lucian, The Runaways, 13. "Sacred" anchors may have borne reliefs of divine names (Moll [supra n. 1] 305) but were certainly not protective idols set on the stern of a ship: Svornos (supra n. 37) 106-110. Another means to slow a fast-driving ship was to drag hawsers in the water: Lucian, Toxaris 19.

Modern authors have suggested other anchor types had specialized uses. Speziale, "Ancora ammiragliato o ancora romana?," Rivista marittima 3 (1938) 36-39, and Frost (supra n. 26) 57-58, have proposed that wooden anchors and wood-sheathed iron anchors were used for muddy seabottoms on the assumption that wood prevented anchors from sinking into the mud. Tusa (supra n. 7) 273, and Maltini-Soliani (supra n. 51) 786, suggest that type IIA stocks were used on warships, but Frost (supra n. 57) 11, believes type IV-stocked anchors were used by warships. Carraze (supra n. 40) 17, on the other hand, proposes that removable-stocked anchors were used for quick maneuvering in port. H. Wallace, without any evidence, suggests that stone anchors were fastened to hawsers to avoid untoward strain on the anchor: "Ancient anchors--taking stock," Triton (Jan./Feb.) 1964) 16.

144. Acts 27, 28-30.

145. A list of sounding leads associated with wrecks is given by Kapitän (supra n. 46) 55-61. With a thorough knowledge of bottom sediments a sailor could determine his position at sea by studying sediments trapped in the hollow bottoms of sounding leads: E.G.R. Taylor, The Haven-Finding Art (New York 1957) 35.

146. Appian, The Civil Wars V, 89.

147. Pindar, Pythian Odes X, 50-53, and Livy, Book XXXVI, 30, 9-10, describe anchors on the prow of a ship. Anchor stocks were found in the forward section of the Porticello wreck (Owen [supra n. 29] 126), the wreck at Cap Negret (M. J. Almagro and B. V. Sancho, "Sello inedita de maderas hallado en el pecio del 'Cap Negret' [Ibiza]," RStLiq 34 [1968] 324), the Chrétienne C wreck (Joncheray [supra n. 47] 104), and the Punta Scaletta wreck: Lamboglia (supra n. 38) 24. One method of riding out a storm was to anchor from the bow and row against the wind: Appian (supra n. 146) 89. Polyænus (Strategema, VIII, III, 9, 63) describes anchoring from the quarter of a triaconter. Casson (supra n. 20) fig. 150, records an anchor on the starboard quarter rail. H. H. Brindley, "A Graffito of a Ship at Beit Jibrîn," PEFO (April 1919) 76, and S. C. Humphreys, "Artists Mistakes," IJNA 7 (1978) 78, portray ships anchored by the stern. Philostratos, Life of Apollonius, III, 56; Lucian, A True Story, 42; Quintilian, Book IV, 41; Livy, Book XXVIII, 35, 11; and Ovid, Metamorphoses XV, 695, describe warships anchored with one or two anchors off the bow, and a line to shore from the stern.

148. Demosthenes, Against Dionysodorus, 44, and Plutarch, Lives: Solon, XIX.

149. Casson (supra n. 20) 250, gives the diameters of warship mooring lines as about 3.65 cm and 4.75 cm. Hawsers for the Nemi barges were 15 cm in diameter (Speziale [supra n. 3] 312). A merchantman's anchor cables must have been larger than warships' mooring lines (Casson [supra n. 20] 250), but certainly smaller than barge hawsers.

150. When divers persisted in cutting Alexander's anchor lines at the siege of Tyre, chains were substituted: Arrian, Anabasis of Alexander II, 21, 6-7.

151. Torr (supra n. 37) 69; A. Köster, Das Antike

Seewesen (Berlin 1923) 184-185; and van Nouhuys (supra n. 29) 110, suggest oculi were used as hawsepipes. Moriarty and Marshall (supra n. 18) fig. 16B, illustrate a ship at anchor with a cork float and hawser run through the oculus, but provide no details about the relief other than that it is a Greek sculpture dated 300 B.C. F. Moll, Das Schiff in der Bildenden Kunst (Bonn 1929) E, Iib, 30, portrays a hawser leading from a hole in an aphalaston, but the accuracy of these published sketches must be questioned. Without a shred of secure evidence, it is difficult to determine whether or not hawsepipes were present on ancient ships. For now, we must remain doubtful that they were used.

152. Pliny, Natural History XVI, 13, 34, and Pausanias, Description of Greece: Arcadia VIII, 12, 1. Cork was also used for life rafts: Lucian, Toxaris, 20.

153. Brindley (supra n. 146) 77 and Cosma (supra n. 75) 25. Nance (supra n. 18) 188, suggests that the hawser passed next to the head, where it was held by a strap, and was attached to the crown; if the anchor were too deeply mired, the strap would break and the anchor would be raised by the crown.

154. The Porticello ring may have been opened and bent back around the hawser: Frey, Hentschel and Keith (supra n. 33) 297.

155. Eiseman (supra n. 26) 41. F. Papò, "Archeosub: Il problema della 'ciambella'," MS 12 (1970), illustrates a stone anchor surmounted by a stone ring. The sailors apparently lost both in the attempt to rescue the first.

156. Aeschylus, Suppliants, 441, and Athanaeus, The Diepnosophists V, 207, describe windlasses; Lucian, Navig. 5, describes windlasses and capstans. Benoit (supra n. 37) 187-189, describes the use of what he thinks is a lead capstan head, but later corrects his error when the "head" is determined to be a part of a rig for netting coral: "Nouvelles épaves de Provence III," Gallia 20 (1962) 167. Joncheray (supra n. 47) 103, provides a list of pulleys associated with shipwrecks.

157. Euripides, Iphigenia in Taurica, 1350. Pindar writes of anchors "slung beside the ship" (Pythian Odes IV, 23-25) or "over the prow" (Pythian Odes IV, 191-192).

## REFERENCES CITED

## Ancient Authors

## Greek:

Aeschylus The Suppliant Maidens

Appian Roman History

Aristophanes The Peace

Arrian Anabasis of Alexander

\_\_\_\_\_ Periplus Pontu Euxein

Athanaeus The Deipnosophists

The Bible

Corpus Inscriptionum Atticarum

Demosthenes Against Dionysodorus

Diodorus of Sicily

Euripides Iphigeneia in Taurica

Greek Papyri in the British Museum

Herodotus The Histories

Homer The Iliad

Inscriptiones Graecae

Lucian A True Story

\_\_\_\_\_ Zeus Rants

\_\_\_\_\_ Toxaris

\_\_\_\_\_ The Runaways

\_\_\_\_\_ Lexiphanes

Pausanias Description of Greece: Attica and Arcadia

Philostratus	<u>Imagines</u>
_____	<u>The Life of Apollonius of Tyana</u>
Pindar	<u>The Odes</u>
Plutarch	<u>Lives: Solon and Caius Marcius Coriolanus</u>
Polyaenus	<u>Strategemata</u>
Strabo	<u>The Geography</u>

## Latin:

Valerius Flaccus	<u>Argonautica</u>
Livy	
Lucan	
Ovid	<u>Metamorphoses</u>
Pliny	<u>Natural History</u>
Quintilian	<u>The Institutio Oratoria</u>

Adamesteanu, D. "Αρχαία ἄγκυρα a Metaponto," Adriatica (1970) 307-324.

Ademettla, E. "El mayor cepo de ancla del mundo," CRIS 34 (1961) 12-13.

Almagro, M. J., and B.V. Sancho. "Sello inedita de madera hallado en el pecio del 'Cap Negret' (Ibiza)." RStLig 34 (1968) 323-336.

Amy, R., P.M. Duval, et al. "L'Arc d' Orange," Gallia 15th supplement (1962).

Barnier, G. "Archaeology by Aqualung Diving: A Roman Ship's Anchor Recovered," ILN (Aug. 21, 1954) 298-299.

\_\_\_\_\_ "Découvertes d'outils antiques au fond de la mer" Atti del II Congresso Internazionale di Archeologia Sottomarina (Albenga 1958) 305-315.

Beltran, A. "Objetos romanos de plomo en el Museo de Cartagena y sus inscripciones," Inspeccion general de Museos Arqueologicos: Memorias (1947) 202-209.

\_\_\_\_\_ "Sobre las excavaciones submarinas," Publicaciones del Seminario de Arqueologia y Numismatica Aragonesas 3(1952) 7-27.

\_\_\_\_\_ "Las excavaciones submarinas y los nuevos problemas de la técnica arqueológica," Caesaraugusta III (1953) 140-147.

Benoit, Fernand. "Jas d'ancre a tête de Méduse," Bulletin officiel du Club Alpin Sous-Marin (1950).

\_\_\_\_\_ "XIIe circonscription," Gallia 8 (1950) 129-131.

Benoit, Fernand. "L'aire méditerranéenne de la 'tete coupée'," RStLig 17 (1951) 39-40.

\_\_\_\_\_  
"Nouvelles et correspondance," RA (1951)  
223-228.

\_\_\_\_\_  
"Exploration sous-marine sur les côtes de  
Provence," Provence historique II (1952) 159-162.

\_\_\_\_\_  
"L'archéologie sous-marine en Provence," RStLig  
18 (1952) 266-275.

\_\_\_\_\_  
"Xlle circonscription," Gallia 11 (1953)  
115-116.

\_\_\_\_\_  
"Amphores et céramique de l'épave de Marseille,"  
Gallia 12 (1954) 35-54.

\_\_\_\_\_  
"Jas d'ancre et pièces d'outillage des épaves de  
Provence," RStLig 21 (1955) 117-128.

\_\_\_\_\_  
"Epaves de la cote de Provence. Typologie des  
amphores," Gallia 14 (1956) 23-34.

\_\_\_\_\_  
"Resultats des fouilles sous-marines fouilles et  
projets a Albenga scaphandriers lourds et plongeurs  
autonomes les galeres de Nemi législations sous-marines  
française et italienne," Bulletin officiel du Club  
Alpin Sous-Marin 8 (1956) 2-7.

\_\_\_\_\_  
"Dodécaédre d'Arles et anneau de Vichy," Ogam 9  
(1957) 105-114.

\_\_\_\_\_  
"Têtes coupées de l'époque grecque au moyen  
age," Cahiers ligures de prehistoire d'archeologique  
(1959) 143-149.

\_\_\_\_\_  
"Nouvelles épaves de Provence," Gallia 18 (1960)  
24-25.

Benoit, F. "Nouvelles épaves de Provence (II)," Gallia 18 (1960) 41-56.

\_\_\_\_\_ "Pièces de grément et d'armement en plomb, engins et pièces décoratives trouvées en mer," Atti del III Congresso Internazionale di Archeologia Sottomarina (Barcelona 1961) 395-411.

\_\_\_\_\_ "Fouilles sous-marines. L'épave du Grand Congloué a Marseille," Gallia 14th Supplement (1961).

\_\_\_\_\_ "Nouvelles épaves de Provence (III)," Gallia 20 (1962) 147-176.

Biaggi. "Chronique d'archéologie sous-marine," Etudes corses 21 (1959) 73-74.

Bigorra, S.M. "Notas de epigrafia valenciana," Archivo de prehistoria levantina 5 (1954) 225-249.

Bonino, M. "Ricerca sulla nave romana di Cervia," Atti del III Congresso Internazionale di Archeologia Sottomarina (Barcelona 1961) 316-325.

Boon, G.C. "A Greco-Roman Anchor-Stock from North Wales," Archaeologia atlantica 1.2 (1976) 195-199.

\_\_\_\_\_ "The Porth Felen Anchor-Stock," IJNA 6 (1977) 239-257.

\_\_\_\_\_ "A Graeco-Roman Anchor-Stock from North Wales," AntJ 57 (1977) 10-30.

Bouscaras, A. "Recherches sous-marines au large d'Agde (1951-1953)," RStLig 20 (1954) 47-54.

\_\_\_\_\_ "Recherches sous-marines au large d'Agde," BSAS 24 (1958) 7-20.

Bouscaras, A. "Recherches sous-marines au large d'Agde, (1960)" BSAS 25-27 (1959-61) 29-36.

\_\_\_\_\_ "Notes sur les recherches sous-marines d'Agde," RStLig 30 (1964) 267-287.

\_\_\_\_\_ "Recherches sous-marines au large d'Agde (1965). Epave des bronzes de Rochelongues," BSAS 1 (1965) 81-99.

\_\_\_\_\_ "Recherches sous-marines 1966. Epave des bronzes," BSAS 2 (1966) 5-15.

\_\_\_\_\_ "Recherches sous-marines - été 1967. Epave des bronzes," BSAS 3 (1967) 5-24.

Braemer, F., and J. Marcade. "Céramique et pièces d'ancres trouvées en mer," BCH 77 (1963) 139-154.

Bravo, J. "Arqueologia submarina: Algo más sobre el ancla llamada romana," CRIS 57 (1963) 4-6.

\_\_\_\_\_ "Un cepo de ancla decorado en aguas de Ceuta," RStLig 30 (1964) 309-311.

\_\_\_\_\_ "Arqueologia submarina: Los cepos romanos con alma de madera," CRIS 67 (1964) 4-6.

\_\_\_\_\_ "Arqueologia submarina: Anclas romanas," CRIS 70 (1964) 8-10.

\_\_\_\_\_ "Arqueologia submarina: Mas cepos de anclas romanas en Ceuta," CRIS 78 (1965) 10-11.

\_\_\_\_\_ "Deformaciones de los cepos de anclas romanas," CRIS 83 (1965) 2-4.

Bravo, J., and R. Muñoz, "Arqueología submarina en Ceuta," Revista Archivos del Instituto de Estudios Africanos (Madrid 1965).

\_\_\_\_\_ "Cepos de anclas romanas con relieve," CRIS 86 (1966) 2-4.

\_\_\_\_\_ "Mas sobre anclas romanas," CRIS 95 (1966) 16-17.

Bravo Pérez, J., and J. Bravo Soto. "Vestigos del pasado de Ceuta," Inmersion y ciencia 4 (1972) 5-39.

\_\_\_\_\_ J. Ancorae antiquae, (Ceuta 1976).

Brill, R.H., and J.M. Wampler. "Isotope Studies of Ancient Lead," AJA 81 (1967) 63-77.

\_\_\_\_\_, I.L. Barnes and B. Adams. "Lead Isotopes in Some Ancient Egyptian Objects, Recent Advances in Science and Technology of Materials," vol. 3, A. Bishay editor (New York 1971) 9-27.

Brindley, H. H. "A Graffito of a Ship at Beit Jibrín," PEFQ (April 1919) 76-78.

\_\_\_\_\_ "A Bronze Age Anchor," MM 13 (1927) 5-13.

Calmes, R. "Le gisement grec, ou étrusque, de l'anse du Dattier," CAS 5 (1975) 43-50.

Caristie, A. Monuments antiques à Orange (Paris 1856).

Carraze, F. "L'ancre de misericordé dans la marine antique," Archeologia 61 (1973) 3-19.

- Carraze, F. "Note on two decorated lead anchor stocks," IJNA 3 (1974) 153-157.
- \_\_\_\_\_ "L'épave Grand Ribaud 'A' sondages et travaux préliminaires," CAS 4 (1975) 19-52.
- Casson, L. "More Sea-Digging," Archaeology 10 (1957) 248-257.
- \_\_\_\_\_ Ships and Seamanship in the Ancient World (Princeton 1971).
- Cavalier, M. "L'épave de Capo Graziano," Archeologia: Trésors des ages 17 (1967) 39-41.
- Charlin, G., J.M. Gassend and R. Lequément. "L'épave antique de la baie de Cavalière (Le Lavandou, Var)," Archaeonautica 2 (1978) 9-93.
- Chavane, M.-J. Salamine de Chypre Volume VI (Paris 1975).
- Comfort, H. "Sigillata from the Ships at Lake Nemi," Rei cretariae romanae fautores, Acta 2 (1959) 5-12.
- Cosma, V. "Anchors from Tomis," IJNA 2 (1973) 235-241.
- \_\_\_\_\_ "Ancore din Tomis," Studii si cerceturi de istorie veche si archeologie 25 (1974).
- \_\_\_\_\_ "Anchors from Tomis 2," IJNA 4 (1975) 21-26.
- Cunliffe, B. "The Late Iron Age Metalwork from Bulbury, Dorset," AntJ 52 (1972) 293-308.
- D'Angelo, G. Anfore e ancore sommerse (Pisa 1980).

- D'Arms, J. H. Commerce and Social Standing in Ancient Rome (Cambridge, Mass. 1981).
- Davies, P.N. "CNA North West Region," IJNA 4 (1975) 388.
- Degrassi, A. I Fasti Consulari dell'Impero Romano (Rome 1952).
- Dei, R., and S. de Fe. "27 Ancore in un cucchiano," MS 2 (1964) 87-99.
- de Jáuregui, J. J. "Exploraciones submarinas en Cartagena y San Pedro del Pinatar," Cronica del III Congreso Arqueologico del Sudest Español (Murcia 1947) 111-118.
- \_\_\_\_\_ "Exploraciones submarinas en Cartagena y San Pedro del Pinatar," ArchEspArg 21 (1948) 38-47.
- \_\_\_\_\_ "Sobre unas posibles medidas de sal punicas encontradas en exploracion submarina en San Pedro del Pinatar," I Congreso Arqueologico del Marruecos Español (Tetuan 1953) 277-281.
- Delgado, J.J.J.G., and A.B. Martinez. "Acerca de unas anclas romanas del Museo de Cartagena," Boletin arqueologico del sudeste Español (1946) 334-345.
- Demangel, R. M. "Recherches sous-marines en Grece," CRAI (1950) 322-324.
- Deneauve, J. "Lampes de Carthage" (Paris 1969).
- Deonna, W. Exploration archéologique de Délos volume 18 (Paris 1938).
- de Santerre, H. G. "Recherches et trouvailles sous-marines faites le long dorivage languedocien et roussillonnais," Atti del II Congresso Internazionale di Archeologia Sottomarina (Albenga 1958) 215-218.

de Solla Price, D. J. "An Ancient Greek Computer,"  
Scientific American (June 1959) 60-67.

Deubner, L. "Zum Astragalspiel," AA 44 (1929) 272-281

de Urquiola, L. M. "Arqueologia submarina: Arqueologia  
submarina en Vizcaya," CRIS 45 (1962) 6-11.

Dimitrov, B. "Anchors from the Ancient Ports of Sozopol,"  
IJNA 6 (1977) 156-163.

\_\_\_\_\_ "Underwater Research Along the South Bulgarian  
Black Sea Coast in 1976 and 1977," IJNA 8 (1979) 70-79.

Dirole, P. Promenades d'archéologie sous-marine (Paris  
1952).

di Stefano, A. "Ischia Lead Foundry," IJNA 4 (1975)  
383-384.

Domain and Zaggia. "Archeosub: Il pezzo a tre buchi," MS 12  
(1970) 206.

Dominguez, D.J.B. "Investigaciones submarinas en la Isla de  
Nueva Tabarca. (Alcante)," Actas de Premier Congresso  
Espanol de Estudios Clasicos (Madrid 1956) 290-296.

Donnadieu. "Découverte d'une ancre antique," Bulletin  
officiel du Club Alpin Sous-Marin (1949).

Dumas, F. Deep-Water Archaeology (London 1962).

\_\_\_\_\_ Épaves antiques: Introduction à l'archéologie  
sous-marine méditerranéenne (Paris 1964).

\_\_\_\_\_ "Exploration sommaire de certaines zones  
cotières d'îles de Marseille," CAS 1 (1972) 109-113.

Durrbach, F., and P. Roussel, Inscriptions de Delos vols. 1 and 3 (Paris 1929 and 1935).

Eiseman, C. J. The Porticello Shipwreck: A Mediterranean Merchant Vessel of 415-385 B.C. (unpublished dissertation, Philadelphia 1979).

Elia, O. "Il portico dei Triclini del Pagus Maritimus di Pompei," BdA 46 (1961) 200-211.

Fiore, P. "Ancora sul cippo di Quinto Cecilio," Sicilia archeologia 18-20 (1972) 75-82.

Fiori, P. "Notes archéologiques (Alpes-Maritimes)," CAS 1 (1972) 115-117.

\_\_\_\_\_  
Le mouillage antique du Cap Gros," CAS 3 (1974) 81-102.

Fita, F. "Inscripciones griegas, latinas y hebras," Boletín de la Real Academia de la Historia 48 (1906) 155-168.

Foerster, F. "La exploracion del pecio de Isla Pedrosa," CRIS 31 (1961) 21-23.

\_\_\_\_\_  
"El problema de la fijacion de los cepos en las anclas que se utilizaban en la antigüedad," CRIS 42 (1962) 29-30.

\_\_\_\_\_  
"Arqueologia submarina: Ideas sobre la evolucion en la construccion de las anclas hasta la epoca romana," CRIS 49 (1963) 8-10.

\_\_\_\_\_  
"Arqueologia submarina: El problema de la confección de las anclas antiguas con cepo de plomo," CRIS 54 (1963) 4-7.

\_\_\_\_\_  
"Arqueologia submarina: Una hipotesis sobre el origen del ancla de dos puntas, con cepo," CRIS 59

(1963) 8-11.

Foerster, F. "Arqueologia submarina: Carta abierto a los piratas," CRIS 65 (1964) 17.

\_\_\_\_\_ "Un cepo de ancla de piedra pizarra ante el puerto de Estartit," RStLig 30 (1964) 306-308.

\_\_\_\_\_ "Un ancla romana de hierro," CRIS 122 (1969) 22-23.

\_\_\_\_\_ and R. Pascual. "La nave romana de 'Sa Nau Perduda' (Cabo Bagur, Gerona)," RStLig 36 (1970) 273-306.

\_\_\_\_\_ "Un cepo de ancla en plomo con decoracion," CRIS 135 (1972) 13.

\_\_\_\_\_ "Arrainguras en el Mediterraneo? Y por qué no?," CRIS 137 (1972) 24-25.

Foerster, Laures F. "Un cepo de ancla en piedra pizarra," CRIS 134 (1971) 27.

\_\_\_\_\_ "Un cepo de ancla romana, con decoración, frente a Tamariu," CRIS 152 (1976) 18-19.

Fonquerle, D. "Les instruments d'ancrage en pierre au Musée d'Agde," Revue Archéologique de Narbonnaise 4 (1971) 207-215.

Frey, D., F.D. Hentschel and D.H. Keith. "Deepwater Archaeology. The Capistello Wreck Excavation, Lipari, Aeolian Islands," IJNA 7 (1978) 279-300.

Froehner, W. Musée de Marseille. Catalogue des antiquités grecques et romaines (Paris 1897).

Frost, H. "From Rope to Chain. On the Development of

- Anchors in the Mediterranean," MM 49 (1963) 1-20.
- Frost, H. Under the Mediterranean (London 1965).
- \_\_\_\_\_ "Segreti dello Stagnone: canali e relitti  
perduti intorno a Mozia," Sicilia archeologia 13 (1971)  
5-12.
- \_\_\_\_\_ "Discovery of a Punic Ship." IJNA 1 (1972)  
113-117.
- \_\_\_\_\_ "The Birth of the Stocked Anchor and the Maximum  
Size of Early Ships. Thoughts Prompted by Discoveries  
at Kition Bamboula, Cyprus," MM 68 (1982) 263-273.
- Garcia y Bellido, A. "Marca de M. Tuccius Galeo en Cadiz,"  
RStLig 35 (1969) 143-144.
- Gargallo, P.N. "Ancore sommerse," MS 1 (1959) 27-30.
- \_\_\_\_\_ "Esplorazioni e recuperi nella Sicilia  
sud-orientale," Centro Italiano Ricercatori Subaquei  
Bolletino ed Atti (1958-1959) 73-80.
- \_\_\_\_\_ "Anchors of Antiquity," Archaeology 14 (1961)  
31-35.
- \_\_\_\_\_ "The Ports of Ancient Syracuse," Archaeology 23  
(1970) 312-317.
- Gianfrotta, P.A. "Le àncore votive di Sostrato di Egina e  
di Faillo di Crotone," La parola del passato (1975)  
311-318.
- \_\_\_\_\_ "First Elements for the Dating of Stone Anchor  
Stocks," IJNA 6 (1977) 285-292.
- \_\_\_\_\_ "Un Ceppo di C. Aquillo Proculo tra i  
rinvenimenti archeologici sottomarini a Punta Licosa  
nel Cilento", Forma Maris Antiqui 10 (1973-1974)

(Bordighera 1980).

- Gianfrotta, P.A. "Ancore 'romane'. Nuovi materiali per lo studio dei traffici marittimi," MAAR (1980) 103-116; figs. 1-31.
- \_\_\_\_\_ and P. Pomey. Archeologia subacquea: storia, tecniche, scoperte e relitti (Milan 1980).
- Giles, H. A. "Chinese Anchors," MM 11 (1925) 328.
- Giustolisi, V. "Le navi romane di Terrasini e l'avventura d'Amilcare sul Monte Heirkte," Sicilia archeologica vol. 3 (1975).
- Gorbea, M. A. "Hallazagos arqueologicos submarinos en la Isla de Ibiza," Trabajo de prehistoria 26 (1969) 349-365.
- Granier, J. "Trouvailles fortuites et 'glanes' archéologiques sur le littoral gardois," RStLig 31 (1965) 253-300.
- Graves, R. The Greek Myths vol. 1 (Baltimore 1955).
- Guido, M. "Archaeology Without Digging: First Reports of an Underwater Survey of the Coasts and Ancient Harbours of Sicily," ILN (February 21, 1959) 298-300.
- Guilera, J. C. "Recuperación de piezas de plomo en el litoral catalan," Atti del III Congresso Internazionale di Archeologia Sottomarina (Barcelona 1961) 140-142.
- Homolle, T. "Comptes des hiéropes du temple d'Apollon Délián," BCH 6 (1882) 130.
- Humphreys, S. C. "Artists' Mistakes," IJNA 7 (1978) 78-79.
- Inglieri, R. U. "Notizie degli scavi: Genova--ceppo di ancora antica trovato nel porto della citta," Atti della Real Accademia Nazionale dei Lincei (1957) 209-211.

Jacono, L. "Le ancore di Nemi e i mosaici di Pompei," Il giornale d'Italia (November 15, 1930) 8.

Jal, A. Glossaire nautique (Paris 1848).

Joncheray, J.-P. "Notes archéologiques (region est-varoise)," CAS 1 (1972) 116-126.

Joncheray, J.-P. "Contribution a l'étude de l'épave Dramont D, dite 'des pelvis'," CAS 2 (1973) 9-49.

\_\_\_\_\_ "Archéologie et plongée: Un exemple d'ancre en bois à jas de plomb," L'aventure sous-marine 92 (1973) 22-25.

\_\_\_\_\_ "Un épave du Bas Empire: Dramont F," CAS 4 (1975) 91-140.

\_\_\_\_\_ "L'épave 'C' de la Chrétienne," CAS 1st supplement (1975).

\_\_\_\_\_ "L'épave grecque, ou étrusque de Bon Porte," CAS 5 (1976) 5-36.

Kapitän, G. "La evolución de la investigación arqueología submarina," CRIS 8 (1959) 16-20.

\_\_\_\_\_ "Arqueologia submarina: La evolucion de la investigación arqueologica submarina," CRIS 9 (1959) 17-19.

\_\_\_\_\_ "Bemerkungen über einen antiken Holzanker und zum Thema 'Archäologische Funde'," Delphin 6 (August 1960) 969-971.

\_\_\_\_\_ "Ein wichtiger Fund in Syrakus," Delphin 8 (August 1967) 21-22.

Kapitán, G. "Der Ankerfund von Syrakus. Zur Frage der Datierung des bleigefüllten hölzernen Ankerstocks aus dem Großen Hafen von Syrakus," Delphin (March 1968) 14-16 and 32.

\_\_\_\_\_ "A New Type of Anchor Stock," Archaeology 21 (1968) 63.

\_\_\_\_\_ "Sul Lakkios, porto piccolo di Siracusia del periodo greco. Ricerche di topografia sottomarina," Archivio storico siracusano 13-14 (1967-1968) 167-180.

\_\_\_\_\_ "Un hallazgo arqueológico importante en Siracusa," CRIS 120 (1969) 26-31.

\_\_\_\_\_ "Rinvenuta nel mare dell' Isola Lunga un'ancora antico a ceppo smontabile," Sicilia archeologia 16 (December, 1971) 13-22.

\_\_\_\_\_ "New Evidence of Ancient Anchors," Archaeology 24 (1971) 52-53.

\_\_\_\_\_ "Ancient Anchors and Lead Plummets," Sefunim 3 (1969-1971) 51-61.

\_\_\_\_\_ "Greco-Roman Anchors and the Evidence for the One-Armed Wooden Anchor in Antiquity," Marine Archaeology D. J. Blackman editor (London 1973) 383-395.

\_\_\_\_\_ "Anchor with Wooden Remains from Haifa, and the Technique of Junction of Wooden Anchors," Sefunim 5 (1976) 33-41.

\_\_\_\_\_ "I relitti di Capo Graziano (Filicudi): scoperte dalla spedizione NACSAC nel 1968," Sicilia archeologia 34 (August, 1977) 40-53.

\_\_\_\_\_ "Exploration at Cape Graziano, Filicudi, Aeolian Islands, 1977. Results with Annotations on the

Typology of Ancient Anchors," IJNA 7 (1978) 269-277.

Kapitän, G. "On Stone-Stocked Greek Anchors as Found in Thracia Pontica: Suggested Reconstruction of their Wooden Parts," Thracia Pontica 1 (Sofia 1982) 290-299.

\_\_\_\_\_  
"Meersarchäologie in Bulgarien-Ankerfunde im Schwarzen Meer," Das Logbuch 16 (1980) 45-48.

\_\_\_\_\_  
"Ancient Anchors--Technology and Classification," (Lecture for the European Intensive Course "Preservation of the Underwater Nautical and Maritime Heritage," Bodrum 1982--unpublished).

\_\_\_\_\_  
Review of Ancorae Antiquae. Per una cronologia preliminare delle ancore del Mediterraneo, IJNA 11 (1982) 179-184.

Kirk, G. S. "Ships on Geometric Vases," BSA (1949) 93-153.

Körber, K. "Die in den Jahren 1914 and 1915 gefundenen römischen Inschriften und Bildwerke im Altertumsmuseum der Stadt Mainz," MZ 10 (1915) 112-120.

Köster, A. Das Antike Seewesen (Berlin 1923).

Lamboglia, N. "Per una classificazione preliminare della ceramica campana," Atti del I Congresso Internazionale di Studi Liguri (Bordighera 1950) 136-206.

\_\_\_\_\_  
"Un áncora romana all Isola Gallinaria," Rivista Inguana e Intemelia 12 (1957) 82.

\_\_\_\_\_  
"Rilievi e recuperi archeologici intorno all'Isola Gallinaria," Atti del II Congresso Internazionale di Archeologia Sottomarina (Albenga 1958) 132-142.

\_\_\_\_\_  
"Un áncora romana all'Isola Gallinaria," Rivista Inguana e Intemelia 14 (1959) 131.

- Lamboglia, N. "Ancore ed anfore a Santo Stefano al mare e a Sanremo," Rivista Inguana e Intemelia 17 (1962) 72.
- \_\_\_\_\_ "Ricerche e scoperte d'archeologia sottomarina in Liguria dal 1959 al 1961," Atti del III Congresso Internazionale di Archeologia Sottomarina (Barcelona 1961) 176-192.
- \_\_\_\_\_ "Ancora un ceppo romano alla Gallinara," Rivista Inguana e Intemelia 18 (1963) 109.
- \_\_\_\_\_ "La Campagna 1963 sul relitto di Punta Scaletta all'Isola di Giannutri," RStLig 30 (1964) 229-257.
- Laubenheimer-Leenhardt, F., and H.G. de Santerre, "Recherches sur les lingots de cuivre et de plomb d'epoque romaine dans les régions de Languedoc-Roussillon et de Provence-Corse," Revue archéologique de Narbonnaise 3rd supplement (1973).
- Leutić, J. "Spojnica antiukos sidra iz Pomorskog Muzeja u Dubrovniku," Anali Historijskog Instituta Jugoslavenske Akademije Znanosti i Umjetnosti u Dubrovniku, Godi 8-9 (1962) 31-35.
- Liou, B. "Direction recherches archéologiques sous marines," Gallia 31 (1973) 571-608.
- \_\_\_\_\_ "Direction des recherches archéologiques sous-marines," Gallia 33 (1975) 571-605.
- Livadie, C. A. "L'épave étrusque du Cap d'Antibes," RStLig 33 (1967) 300-326.
- Lord, W. B. "Anchors," The Nautical Magazine 70 (March 1901) 135-144.
- Maggiani, A. "Isola d'Elba" BdA 4th supplement (1982) 62-64.

- Magnon, L. "Essai de reconstitution de l'ancre du Musée d'Archéologie de Marseille," RA 2 (1894) 220-230.
- Maia, M. "Cepos de chumbo de âncoras romanas encontrados ao largo de Sesimbra," Setúbal arqueologia 1 (1975) 177-180.
- Maltini-Soliani. "Un raro ceppo ancora da decifrare," MS 8/9 (1967) 784-786.
- Martin, G. and J. Saludes. "Hallazgos arqueológicos submarino en la zona de El Saler (Valencia)," Archivo de prehistoria levantica 11 (1966) 155-169.
- Martínez-Hidalgo y Terán, J. "El problema del ancla y las naves de Caligula," Revista general de marina 124 (June 1943) 771-775.
- McCann, A. M. "A Fourth Century B.C. Shipwreck near Taranto," Archaeology 25 (1972) 180-187.
- Mercanti, M. P. Ancorae antiquae. Per una cronologia preliminare delle ancore del Mediterraneo. (Rome 1979).
- Merlin, A. "Lingots et ancres trouvés en mer près de Mahdia (Tunisie)," Melanges Cagnat 32 (1912) 383-397.
- \_\_\_\_\_ and L. Poinssot. "Cratères et candélabres de marbre trouvés en mer pres de Mahdia," Notes & documents publiés par la Direction des Antiquités et Arts (Tunis 1930).
- \_\_\_\_\_ "Submarine Discoveries in the Mediterranean," Antiquity 4 (1930) 405-414.
- Mingazzi, P. "Alle foci del Garigliano," Monumenti antichi 37 (1938) 913 and pl. XLII.
- Moll, F. "A Bronze-Age Anchor," MM 13 (1927) 183-184.

Moll, F. "The History of the Anchor," MM 13 (1927) 213-332.

\_\_\_\_\_ "Ein Bleianker," AA 14 (1929) 265-272.

\_\_\_\_\_ Das Schiff in der Bildenden Kunst (Bonn 1929).

Moretti, L. Inscrizioni agonistiche greche (Rome 1953).

Moriarty, J.R., and N.F. Marshall. "The History and Evolution of Anchors," CEDAM International Bulletin 4 (1971).

Mouchot, D. "Pièces d'ancres, organeaux et ornements de plomb antiques découverts entre Antibes et Monaco," RStLig 36 (1970) 307-318.

Murray, M. A. Excavations in Malta (London 1925).

\_\_\_\_\_ "A Bronze-Age Anchor," MM 13 (1927) 275-277.

Nance, R. M. "Anchors," MM 14 (1928) 163-165.

\_\_\_\_\_ "Roman Anchors Found at Nemi," MM 18 (1932) 188.

Nikolanci, M. "Neki pomorski predmeti i spomenici iz srednje dalmacije," Ujesnik 55 (1953) 166-179.

Oliva Prat, M. "Un anfora griega pescada en la Costa Brava," Anales de estudios gerundenses 6 (1951) 348-353.

\_\_\_\_\_ "Un cepo de ancla hallado en aguas de cadaques Costa Brava (Gerona), Publicaciones del Seminario de Arqueología y Numismática Aragonesas 4 (1954) 190-192.

\_\_\_\_\_ "Estado actual de la arqueología submarina en la Costa Brava (Gerona, Espana). Ultimas prospecciones

y hallazgos. Avance para un estudio de conjunto," Atti del II Congresso Internazionale di Archeologia Sottomarina (Albenga 1958) 221-245.

Olschki, A. "L'importanza di chiamarsi Giannutri," MS 2 (1964) 75-78.

Owen, D. I. "Excavating a Classical Shipwreck," Archaeology 24(1971) 118-129.

The Oxford Classical Dictionary N.G.L. Hammond and H.H. Scullard editors (New York 1976).

Pallarés Salvador, F. "Tipologia y cronologia preliminar de las anclas antiguas," Atti del III Congresso Internazionale di Archeologia Sottomarina (Barcelona 1961) 384-393.

\_\_\_\_\_ "Prospecciones con la nave Daino en aguas catalanas," RStLig 38 (1964) 295-301.

\_\_\_\_\_ "La primera exploración sistemática del pecio del Sec (Palma de Mallorca)," RstLig 38 (1972) 287-326.

Papò, F. "Ancore all'ingrosso," MS 7 (1961) 52-55..

\_\_\_\_\_ "Mare antico: Un'ancora per ricordo," MS 7-8 (1963) 129.

\_\_\_\_\_ "Mare antico: Un'ancora a forma di sasso," MS 10 (1963) 122-123.

\_\_\_\_\_ "Mare antico: L'ancora che guida al relitto," MS 11 (1963) 119-120.

\_\_\_\_\_ "Mare antico: L'aratro del bifolcomarinaio," MS 12 (1963) 125-126.

\_\_\_\_\_ "Mare antico: Un braccio dal polso di piombo," MS

2 (1964) 143-144.

Papò, F. "Mare antico: Il ceppo e i suoi compagni," MS 3  
(1964) 142-143.

\_\_\_\_\_ "Mare antico: Non parla veneto ne'inglese," MS 4  
(1964) 156-157.

\_\_\_\_\_ "Mare antico: Il 'solitario' di Acitrezza," MS 5  
(1964) 153-154.

\_\_\_\_\_ "Mare antico: Ha ancorato quaranta generazioni,"  
MS 6 (1964) 155-156.

\_\_\_\_\_ "Mare antico: Nel braciere la sua eta'," MS 7  
(1964) 155-156.

\_\_\_\_\_ "Mare antico: Un'anfora piena di tritolo," MS 8  
(1964) 171-172.

\_\_\_\_\_ "Mare antico: Due ritrovatori 'pulti'," MS 9  
(1964) 162.

\_\_\_\_\_ "Mare antico: Un ceppo con la coda di paglia,"  
MS 10 (1964) 170.

\_\_\_\_\_ "Mare antico: Colpo da otto sulla via delle  
ancore," MS 11 (1964) 170-171.

\_\_\_\_\_ "Mare antico: Al passo con l'impero," MS 12  
(1964) 156-157.

\_\_\_\_\_ "Mare antico: Un ceppo in maschera," MS 1 (1965)  
140-141.

\_\_\_\_\_ "Mare antico: L'ancora della congiuntura," MS 4  
(1965) 488-489.

\_\_\_\_\_ "Mare antico: L'ancora del miracolo," MS 5

(1965) 603.

Papò, F. "Mare antico: La testimonianza di Cesare," MS 6  
(1965) 730-731.

\_\_\_\_\_ "Mare antico: Il poker dei solitari," MS 7  
(1965) 854.

\_\_\_\_\_ "Mare antico: L'attrezzo fantasma," MS 8 (1965)  
966-967.

\_\_\_\_\_ "Mare antico: La fabbrica delle anfore," MS 9  
(1965) 1077-1078.

\_\_\_\_\_ "Mare antico: Ancore e fumarole," MS 10 (1965)  
1188-1189.

\_\_\_\_\_ "Mare antico: Eccole tutte insieme," MS 12  
(1965) 1413-1416.

\_\_\_\_\_ "Mare antico: Burocrazia all'ancora," MS 1  
(1966) 76.

\_\_\_\_\_ "Mare antico: Un'anfora per gli dei," MS 2  
(1966) 174-175.

\_\_\_\_\_ "Mare antico: I gemelli di piombo," MS 4 (1966)  
393.

\_\_\_\_\_ "Mare antico: Il ceppo più effigiato," MS 5  
(1966) 514.

\_\_\_\_\_ "Mare antico: Il Museo di Palermo," MS 6 (1966)  
659-660.

\_\_\_\_\_ "Mare antico: Ma allora c'è un relitto," MS 7  
(1966) 767-768.

\_\_\_\_\_ "Mare antico: Cannone da salotto," MS 9 (1966)

928-929.

Papò, F. "Mare antico: Anche in Cirenaica ancora di  
pietra," MS 10 (1966) 1033-1034.

\_\_\_\_\_ "Mare antico: L'ancora fantasma," MS 11 (1966)  
1132.

\_\_\_\_\_ "Mare antico: La fabbrica di Aquileia," MS 12  
(1966) 1219-1220.

\_\_\_\_\_ "Mare antico: Ma che sono questi anelli?," MS 3  
(1967) 271-272.

\_\_\_\_\_ "Archeosub," MS 12 (1967) 1098-1105.

\_\_\_\_\_ "Mare antico: Le anfore del Mar Nero," MS 5  
(1969) 565-567.

\_\_\_\_\_ "Mare antico: Due anfore imperiali," MS 7 (1969)  
814-816.

\_\_\_\_\_ "Archeosub: Un ceppo da recuperare," MS 4 (1970)  
487.

\_\_\_\_\_ "Archeo," MS 10 (1970) 1137-1139.

\_\_\_\_\_ "Archeosub: Il problems della 'ciambella'," MS  
12 (1970).

\_\_\_\_\_ "Archeosub: Trovato il ceppo e perso il  
relitto," MS 4 (1971) 554-555.

\_\_\_\_\_ "Archeosub: Il ceppo di pietra," MS 7 (1971).

\_\_\_\_\_ "Archeosub: Le ancore litiche di Capo Miseno,"  
MS 10 (1971).

- Papò, F. "Archeosub: L'anfore punica," MS 1 (1972).
- \_\_\_\_\_ "Archeosub: Il ceppo di mezzo canale," MS 1  
(1973) 124.
- \_\_\_\_\_ "Archeosub: Un nuovo ceppo mobile," MS 2 (1973)  
1133-1134.
- \_\_\_\_\_ "Archeosub: I ceppi con gli astragali," MS 4  
(1973).
- \_\_\_\_\_ "Archeosub: L'ancora litica di Civitavecchia,"  
MS 5 (1973).
- \_\_\_\_\_ "Archeosub: L'anfora regalata," MS 10 (1973).
- \_\_\_\_\_ "Archeosub: Un ceppo antichissimo," MS 12  
(1973).
- Pasarius, J. M. "El trafico maritimo en Mallorca en la antigüedad clasica," Atti del III Congresso Internazionale di Archeologia Sottomarina (Barcelona 1961) 69-86.
- Pascual Gausch, R. "Cepos de ancla romanos recuperados frente a Blanes (Barcelona)," Zephyrus 10 (1959) 176-180.
- \_\_\_\_\_ "Materiales de procedencia submarina depositados en el Museo Municipal de San Feliu de Guixols," Anales Instituto de Estudio Gerundenses del Patronato Jose M. Quadro 15 (1961-1962) 281-292.
- \_\_\_\_\_ "Ricon del pasado: Arqueología submarina en Valencia," CRIS 98 (1967) 24-25.
- \_\_\_\_\_ "Underwater Archaeology in Andalusia (Almeria and Granada)," IJNA 2 (1973) 107-119.

Pascaul Gausch, R. "Las ánforas de Isla Pedrosa," Inmersion y ciencia 12 (1975) 87-92.

\_\_\_\_\_ "Cepo de ancla en piedra en aguas del Mar Egeo," CRIS 151 (1976) 21.

\_\_\_\_\_ and Esteva, L. "Materiales de procedencia submarina depositados en el Museo Municipal de Feliu de Guixols," Atti del III Congresso Internazionale di Archeologia Sottomarina (Barcelona 1961) 105-116.

Pederzini, A. "Archeologia: Catasto archeologico dei fondali dell'Isola Gallinaria ed esplorazione del relitto della nave romana di Albenga," Centro Italiano Riceratori Subaquei, Bolletino ed Atti (1957) 9-19.

\_\_\_\_\_ "Rinvenimenti e recuperi all' Isola d'Elba," Centro Italiano Riceratori Subaquei, Bolletino ed Atti (1958) 21-26.

Peman, C. "Sobre el casco griego del Guadalete," ArchEspArg 14 (1940-1941) 407-414.

Picozzi, S. "L'archeologo: Vita di un'ancora," Il subacqueo 2 (1973) 74-76.

\_\_\_\_\_ "L'archeologo: Tre buchi in una pietra," Il subacqueo 9 (1974) 72-75.

\_\_\_\_\_ "L'archeologo: L'ancora a un braccio solo," Il subacqueo 13 (1974) 71-73.

Piepers, W. "Teile römischer Schiffsanker von Niederrhein," BonnJbb 174 (1974) 561-566.

Poidebard, R. P. A. "Explorations sous-marines a Carthage et a Mahdia avec l'avis 'Élie-Monnier' du groupe de recherche sous-marine (Juin 1948)," CRAI (1948) 379-388.

Ponce i Garrido, A. M. "Descripción de algunas de las piezas halladas en el yacimiento de Isla Pedrosa," Inmersion y ciencia 14 (1975) 95-111.

Pruvot, G. Épave antique etrusco-punique an cap d'Antibes 6<sup>e</sup> s. av. J.-C. (Antibes 1971).

\_\_\_\_\_ "Un navire etrusco-punique an cap d'Antibes 6<sup>e</sup> s. avant Jesus-Christ," Archeologia: Trésors des ages 48 (1972) 16-19.

Purpura, G. "Il relitto di Terrasini," Sicilia archeologia 24-25 (1975) 45-61.

Rebikoff, D. "Les releuvers d'épaves arrachent chaque année des fortunes à la mer," Science et vie (September 1954) 231-241.

Reina, A. "Cepo de plomo de ancla romana, de decomunales proporciones, recuperado en aguas de la bahia de Cadiz," CRIS 134 (1971) 20-21.

\_\_\_\_\_ "Cuando las barbas de tu vecino veas cortar...," CRIS 142 (1973) 20-21.

Remer-Miller, J. "Ancient Anchors in Antibes: a Study. Including a Catalogue of Anchors in the Musée Archéologique and the Musée Naval of Antibes," Antipolis 1 (1974) 17-36.

Ripoll Perello, E. "Notas de arqueologia de Catalona y Balaeres," Ampurias 24 (1962) 311-313.

Rivera, C. G., and D.L. de la Orden. "Elementos de anclas antiguas del Museo de Cadiz," Boletin del Museo de Cadiz 2 (1979-1980) 67-72.

Rocca, S., B. Michelini and G. Michelini. Osservazioni archeologiche sottomarine (Palermo 1962).

Rochier, R. "Note sur un plus gros jas d'ancre antique

connue," CAS 4 (1975) 149-150.

Roghi, G. "Scoperta del relitto di Capo Graziano (Filicudi, Isole Lipari)," RstLig 28 (1960) 364-367.

Roghi, G. "La nave romana di Capo Graziano," Atti del III Congresso Internazionale di Archeologia Sottomarina (Barcelona 1961) 253-260.

Rohlf, G. Antikes Knöchelspiel im Einstigen Grossgriechenland (Tubingen 1963).

Roschach, E. "Ancora," Dictionnaire des antiquites grecques et romaines C. V. Daremberg and E. Saglio editors (Paris 1877).

Rostovtzeff, M. The Social and Economic History of the Hellenistic World vol. 3 (Oxford 1941).

Rouse, W. H. D. Greek Votive Offerings: An Essay in the History of Greek Religion (Cambridge 1902).

Santamaria, C. "L'épave A du Cap Dramont (Saint-Raphaël): Fouilles 1971-1974," Revue archæologique de Narbonnaise, (1975) 184-198.

Sarra, M. "Ancore a galla," MS 5 (1960) 48-56.

Schlumberger, M. "Séance du 11 Février," Societe Nationale des Antiquaries de France, Bulletin (1880) 84-93.

Sciarra, B. "Ricuperi sottomarini nel Brindisino," RstLig 32 (1966) 341-352.

\_\_\_\_\_ "Ricuperi lungo il litorale Brindisino," Studi Salentini Seh. D.C. (1969) 336-342.

Secci, L. "Un ceppo d'ancora romana," Genova 35 (1958) 20-21.

Seyrig, H. "Poids antiques de la Syrie et de la Phénicie,"  
Bulletin du Musée de Beyrouth 8 (1946-1948) Plates  
I-VI.

Soriano, M. B. "Los hallazgos arqueológicos submarinos  
ingresados en el Museo Arqueológico de Tarragona,"  
Boletín arqueológico de Tarragona 69-70 (1969-1970)  
3-17.

Speziale, G.C. "The Roman Anchors found at Nemi," MM 17  
(1931) 30-320.

"Ancora ammiragliato o ancora romana?," Rivista  
marittima 3 (1938) 31-50.

Stümpel, B. "Vor und Frühgeschichte 1970/1971," MZ (1974)  
220-263

Svornos, J. N. "Stylides, ancores hierae, aphalasta,  
stoloi, ackrostolia, embola, proembola et totems  
marin," JIAN (1914) 81-152.

Swiney, H.W., and M.L. Katzev. "The Kyrenia Shipwreck: A  
fourth-century B.C. Greek Merchant Ship," Marine  
Archaeology D.J. Blackman editor (London 1973) 339-359.

Taillez, P. "De Mahdia," Revue maritime 37 (1949) 573-585.

Taylor, E.G.R. The Haven-Finding Art (New York 1957).

Taylor, J. du P. Marine Archeology (New York 1965).

Tchernia, A. "Direction des recherches archéologiques  
sous-marines," Gallia 27 (1969) 465-499.

Tchernia, A. "Premiers résultats des fouilles de Juin 1968 sur l'épave 3 de Planier," Etudes classiques 3 (1968-1970) 51-82.

Torelli, M. "Il Santuario di Hera a Gravisca," La parola del passato (1971) 44-67.

Torr, C. "Nouvelles archéologiques et correspondance," RA (January - June 1898) 441-442.

\_\_\_\_\_ Ancient Ships (Chicago 1964).

Tusa, V. "Ricerca archeologica sottomarina sulla costa nord-occidentale della Sicilia," Atti del II Congresso Internazionale di Archeologia Sottomarina (Albenga 1958) 73-79.

\_\_\_\_\_ "I rinvenimenti archeologici sottomarini nella Sicilia nord-occidentale tra il II e III Congresso Internazionale," Atti del III Congresso Internazionale di Archeologia Sottomarina (Barcelona 1961) 263-295.

\_\_\_\_\_ "Ancore di pietra nel Museo Nazionale di Palermo," RStLig 33 (1967) 287-299.

\_\_\_\_\_ "Ancore antiche nel Museo di Palermo," Marine Archaeology D. J. Blackman editor (London 1973) 411-437.

\_\_\_\_\_ "Parlar difficile: Ancore di pietra nel Museo Nazionale di Palermo," Il subacqueo 13 (1974).

Tylecote, R. F. "Welding Technology: The Archaeology of Metal Fabrication in the British Isles," British Welding Journal (1962) 512-522.

\_\_\_\_\_ "Durable Materials for Seawater: the Archaeological Evidence," IJNA 6 (1977) 269-283.

- Ucelli, G. "Scienza e tecnica di Roma documentate dall'impresa di Nemi," Quaderni dell'Impero: La scienza e la tecnica ai tempi di Roma Imperiale 19 (1946).
- \_\_\_\_\_ Le navi di Nemi (Rome 1950).
- Varoqueaux, C. "L'épave du Musée des docks a Marseille," Etudes classiques 3 (1967-1970) 25-50.
- van Doorninck, F. H. "New Evidence Concerning Development in Anchor and Hull Construction Technology during the Roman and Byzantine Period," Papers from the IIIrd United States Naval Academy History Symposium R. W. Love Jr. editor (New York, London 1980) 26-33.
- \_\_\_\_\_ "The Fabrication of some Medieval Iron Anchors at the Bodrum Museum in Turkey," Proceedings of the Thirteenth Conference on Underwater Archaeology (in press).
- van Nouhuys, J.W. "Some 'Kinks' in The History of the Anchor," MM 14 (1928) 108-112.
- \_\_\_\_\_ "The Anchor," MM 37 (1951) 17-47.
- Vidal Sola, C. "Arqueologia submarina: Esperando via nueva legislacion," CRIS 50 (1963) 4-5.
- Vlahov, K., V. Tapkova-Zaimova, V. Popov, and A. Fol. Monumenta thraciae antitiquae III (Sofia 1980).
- Vocino, M. "Dopo duemila anni: L'ancora di Nemi e l'ancora dell'ammiragliato," Corriere della Sera 22 (March 20, 1931) 3.
- Vrsalovic, D. Istraživanja I'Zaštita Podmorskih Arheoloških Spomenika usr Hrvatskoj (Zagreb 1974).

- Wallace, H. "Ancient anchors -- taking stock," Triton (January/February 1964) 14-17.
- Welter, G. "Aeginetica XIII-XXIV," AA 53 (1938) 480-540.
- Whittick, G. C. "The Casting Technique of Romano-British Lead Ingots," JRS (1961) 105-111.
- Will, E. "Variété: La décollation de Méduse," RA 27 (1947) 60-76.
- Zammit. Report on the Working of the Museum Department for the Year 1963 (Malta 1963).
- Zecchini, M. L'archeologia nell'Arcipelago Toscano (Pisa 1971).
- Zevi, F. "Appunti sulle anfore romane," Archeologia classica 18 (1966) 208-247.

## APPENDIX 1

Measurements of type III stocks indicate that several formulas may have been used in stock manufacture. One hundred and twenty-three type III stocks were measured: 7 IIIA, 84 IIIB, and 32 IIIC. Of the total, 121 were measured for width (W) and length (L) of shank (ill. 24), 43 for width (WO) and length (LO) outside the shank box, 97 for arm width (WA) at the shank box and width of arm end (WAE), and 113 for height of box (HB) and height of arm end (HAE).

All calculated correlations are accurate to within  $\pm 15\%$  of the product with an average variable of  $\pm 11\%$  (tables 2 and 3). Although 78% to 100% of stock measurements are shown to be relate in some way, only 44% of the HAE measurements show a constant. Similarly, no correlations for varying HB measurements can be found; 15% of measured stocks have a height less than width, 55% show a height between stock width and length, and 30% have a greater width than length. This variation can be linked to the amount of lead poured into a mold. It is unsure how depths of type III stock molds were determined, or even if molds were completely filled.

On the other hand, more percentages of horizontal measurements are related. The most common factor in tested equations is 1.5. While this evidence does not result in a

simple formula, it does suggest the first elements towards understanding possible theories and practices behind anchor stock creation.

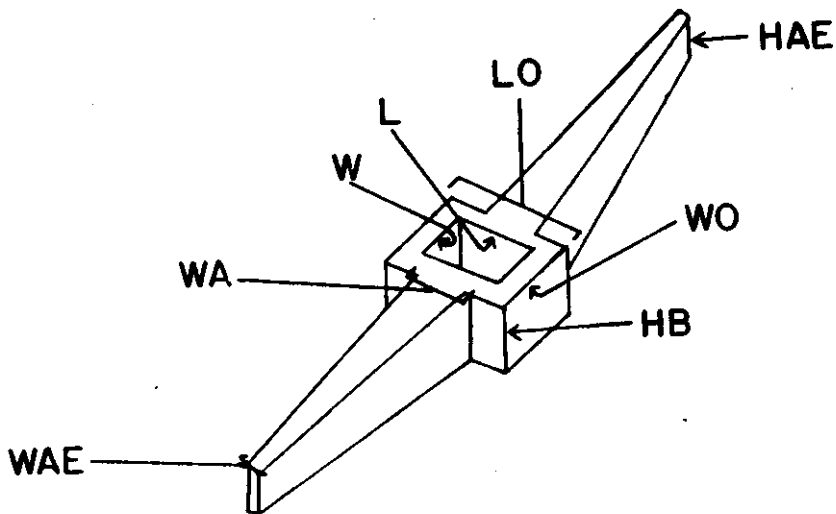

Ill. 24. Drawing of a type III anchor stock with locations of measurements discussed.

TABLE 2. EQUATIONS USED IN COMPUTING ANCHOR STOCK CORRELATIONS WITH RESULTS EXPRESSED AS A PERCENTAGE OF 100.

TYPE III ANCHOR STOCK CORRELATIONS

<u>Equations for L</u>	<u>% of Stocks</u>
L = W	11
L = W x 1.5	71
L = W x 2	9
Total	<u>91%</u>
<u>Equations for WO</u>	
WO = L	72
WO = L x 1.5	4
WO = W x 1.5	2
Total	<u>78%</u>
<u>Equations for LO</u>	
LO = WO	6
LO = WO x 1.5	53
LO = L x 1.5	41
Total	<u>100%</u>
<u>Equations for W</u>	
W = WA	42
W = WA x 1.5	39
W = WA x 2	9
W = WA x 2.5	8
Total	<u>98%</u>
<u>Equations for WA</u>	
WA = WAE	1
WA = WAE x 1.5	42
WA = WAE x 2	46
WA = WAE x 2.5	7
WA = WAE x 3	3
WA = WAE x 3.5	1
Total	<u>100%</u>

Table 3. Published type III anchor stocks and their measurements.

Example: Length overall in meters      Location, Acc. #  
 Width x length  
 Width outside shank box  
           x length outside shank  
           box (WO x LO)  
 Height; width of arm  
 Published by:

Type IIIA

- |    |  |                                   |
|----|--|-----------------------------------|
| 1. | 1.45<br>11.5 x 14<br>22.5 x 24.5<br>9-6; 12-8<br>(Tusa 1961, 1973) | Palermo, #3343<br>Museo Nazionale |
| 2. | 1.48<br>14 x 15<br>23.5 x 24.5<br>9-8; 8.5-6<br>(Tusa 1961, 1973)  | Palermo, #3346<br>Museo Nazionale |

Type IIIB

- |    |  |  |
|----|--|--|
| 3. | .63<br>6 x 8<br>5-3; 6-3<br>(Dirole 1952; Remer-Miller 1974) | Antibes<br>Musée d'Archéologie<br>Bastion St.-Andre                        |
| 4. | .715<br>4.5 x 7<br>12-4.5; 5-3<br>(Mouchot 1970)             | Nice<br>#Cm.5MDo, 601.7A<br>Musée Archéologique                            |
| 5. | .91<br>7.5 x 14.5<br>15 x 20<br>14-10; 7-6<br>(Sciarra 1966) | Brindisi, #14496<br>Museo Archeologico<br>Provinciale Francesco<br>Ribezzo |
| 6. | 1.06<br>6.5 x 13<br>9-5; 6-?<br>(Maia 1975)                  | Sesimbra, #PE67<br>Museo Municipal   |

7. 1.10  
8 x 12  
10 x 14  
12.5-7; 9-4  
(Rivera 1979)  
Cadiz  
Museo Provinciale
8. 1.24  
9.5 x 13  
11.5 x 15.5  
16.5-9.5; 9-4.5  
(Pascaul Gausch 1959; Ripoll Perello 1962)  
Barcelona, #10.166  
Museo Marittimo
9. 1.39  
10 x 14  
14.5-7; 9-2.5  
(Benoit 1959, 1960; Carraze 1973)  
Marseille, #C.130  
Musée Borely
10. 1.44  
10 x 13  
15.5-18  
16-10.5; 6.5-3  
(Tusa 1961)  
Palermo, #3095  
Museo Nazionale
11. 1.51  
9.5 x 15  
15-7; 9-5  
(Oliva Prat 1958; Benoit 1959; Pascaul Gausch 1959;  
Ripoll Perello, 1962)  
Gerona  
Museo Arqueologico
12. 1.53  
14.5 x 18.5  
16-8.5; 9-5.5  
(Mercanti 1979)  
Barcelona, #10.206  
Museo Marittimo
13. 1.59  
13 x 18  
16.5 x 21.5  
17-8.5; 13-6  
(Benoit 1959; Pascaul Gausch 1959; Ripoll Perello  
1962)  
Barcelona  
Museo Marittimo
14. 1.59  
12 x 18  
15 x 8; 9-6  
(Liou 1975)  
St. Raphaël  
Musée Archeologie  
Sous-Marin
15. 1.60  
11 x 17.5  
17-10  
(Joncheray 1972)  
St. Raphaël  
Musée Archeologique  
Sous-Marin

16. 1.67  
17 x 22  
20-16; 13-8  
(Liouss 1975)  
St. Raphaël  
Musée Archéologique  
Sous-Marin
17. 1.76  
13.5 x 20.5  
19.5-10; 9.5-4  
(Mouchot 1970)  
Nice,  
Musée Archéologique
18. 1.89  
16 x 19  
20 x 23  
19-9; 11-6.5  
(Benoit 1950, 1952; Beltran 1952, Dirole 1952)  
Paris, #1411  
Musée de la Marine
19. 1.95  
9 x 21  
16 x 26  
20.5-12.5; 13.5-9  
(Benoit 1950)  
Antibes  
Musée Naval
20. 1.96  
16.5 x 20.5  
23 x 29.5  
18-8; 10-4  
(Remer-Miller 1974)  
Antibes B.S.A.  
Musée Archéologique  
Bastion St.-Andre
21. 2.12  
27 x 31  
37 x 40  
30-22.5; 14-12  
(Sciarra 1966)  
Brindisi  
Museo Archeologico  
Provinciale Francesco  
Ribezzo
22. 2.14  
19 x 25  
26 x 33  
24.5-17.5; 14-10  
(Sciarra 1966)  
Brindisi  
Museo Archeologico  
Provinciale Francesco  
Ribezzo
23. 2.26  
22 x 35  
18-13; 12-8  
(Magnon 1894; Froehner 1897; Benoit 1951, 1952, 1955;  
Dirole 1952; Rochier 1975)  
Marseille, #1517  
Musée Borely
24. 2.28  
25 x 32  
32 x 39  
20-17; 18.5-10.5  
(Merlin 1912; Dirole 1952)  
Toulon  
Musée Naval

25. 2.50  
24 x 31.5  
17-13; 17-8.5  
(Rochier 1975)
- St. Raphaël  
Musée Archéologique  
Sous-Marin
- Type IIIC
26. 84.5  
8 x 12.5  
10 x 15.5  
(Dimitrov 1977)
- Sozopol, #87
27. 1.11  
8 x 12.5  
13 x 17  
8-7; 8-4.5  
(Tusa 1961, 1973)
- Palermo, #3096  
Museo Nazionale
28. 1.24  
16 x 9  
12 x 19  
10-8; 7-5.5  
(Tusa 1961, 1973)
- Palermo, #3358  
Museo Nazionale
29. 1.46  
13.5-9; 7-3  
(Benoit 1960)
- La Ciotat  
Musée Archéologique
30. 1.66  
15 x 20.5  
23 x 28  
18.5-15; 11.5-7.5  
(Tusa 1958)
- Palermo  
Museo Nazionale

APPENDIX 2. ANCHOR STOCKS RECOVERED FROM SHIPWRECKS

Ship	Dimensions	Metric tons	Number of Stocks	Anchor Weight in kg.	Anchor Stock Length in m.	% of Ship's Length	Beam
Cavalière	12.98 x 4.6 m	35.7	1	118.5	1.39	10	30
Kyrenia	15 x 5 m	25	2	-----	c. .73 c. .76	4 5	14 15
Capistello	-----	---	2	86	1.20 .51+	---	----
Chrétienne C	15 x 5 m	50	3	66 84 104	1.25 1.29 1.35	8 8 8	25 25 27
Sa Nau Perduda	15-20 x 5 m*	---	3	-----	1.20	6	24
Porticello	20 m long?	---	2	168 235	1.63 1.92	---	----
Punta Scaletta	30 x 10.75 m*		7	-----	1.60	6	21
Mahdia	30-40 x 10 m	456	5	628 695	2.28 2.35 2.40	6 6 6	22 23 24

\*Beam derived by length divided by 3.5.

## APPENDIX 3

## LETTERS OF PERMISSION

Douglas Haldane has permission to reproduce the following illustrations from the works listed below. These will be for use in his thesis to be submitted to Texas A&M University as a requirement for completion of a Master of Arts degree in Anthropology.

Title: "On Stone Stocked Greek Anchors as found in Thracia Pontica: Suggested Reconstruction of their Wooden Parts," Thracia Pontica 1 (Sofia 1982)

Figure: 5, page 296.

Title: "New Evidence of Ancient Anchors," Archaeology 24 (1971)

Figure: "Drawings of the anchor collar from Brindisi, in section and of the bottom," page 53.

Title: "Exploration at Cape Graziano, Filicudi, Aeolian Islands, 2977," International Journal of Nautical Archaeology 7 (1978)

Figure: 5, page 272.

Title: "Meersarchaeologie in Bulgarian - Ankerfunde im Schwarzen Meer," Das Logbuch 16 (1980)

Figure: 8, page 48.

27.5.1984

Date

Gerhard Kapitän

Gerhard Kapitän

Douglas Haldane has permission to reproduce the following illustrations from the works listed below. These will be for use in his thesis to be submitted to Texas A&M University as a requirement for completion of a Master of Arts degree in Anthropology.

Title: "Essai de reconstruction de l'ancre du Musee d'Archeologie de Marseille," L. Magnon in Revue Archeologique 2 (1894)

Figure: 9, page 226.

Title: "Nouvelles et correspondance," F. Benoit, Revue Archeologique (1951)

Figure: 8, page 225.

II-29-84  
Date

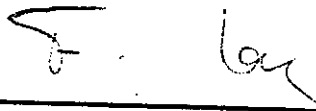
  
\_\_\_\_\_  
for Presses Universitaires  
de France

PRESSES UNIVERSITAIRES  
DE FRANCE

Douglas Haldane has permission to reproduce the following illustrations from the work listed below. These will be for use in his thesis to be submitted to Texas A&M Univeristy as a requirement for completion of a Master of Arts degree in Anthropology.

Title: The Porticello Shipwreck: A Mediterranean Merchant Vessel of 415-385 B.C.

Figure: 2.29

2-20-84  
Date

Cynthia J. Eiseeman  
Dr. Cynthia Eiseeman

Douglas Haldane has permission to reproduce the following illustrations from the works listed below. This will be for use in his thesis to be submitted to Texas A&M University as a requirement for completion of a Master of Arts degree in Anthropology.

Title: "Graffito of a Ship," H. H. Brindley,  
"A Graffito of a Ship at Beit Jibrin,"  
Mariner's Mirror (1919)

Figure: "Graffito of a Ship," page 76

Title: "The Roman Anchors found at Nemi,"  
G. C. Speziale, Mariner's Mirror 17 (1931)

Figures: 1 and 2, pages 314-315.

*THE MARINER'S MIRROR*

(The Quarterly Journal of the  
Society for Nautical Research)

*Brian H. Dolley*

20: ii: 84

Date

Brian H. Dolley  
for Mariner's Mirror

Douglas Haldane has permission to reproduce the following illustration from the work listed below. This will be for use in his thesis to be submitted to Texas A&M University as a requirement for completion of a Master of Arts degree in Anthropology.

Title: "Isola d'Elba," A. Maggiani, in Bolletino d'Arte 4th Supplement, "Archeologia Subaquea," (1982)

Figure: 30, page 63.

3/5/84  
Date

Ernie Moore  
for Bolletino d'Arte

## VITA

David Douglas Haldane was born in West Point, New York, July 19, 1957, to Robert and Elise Haldane. He completed his high school education in Leesville, Louisiana, in 1975. In 1977 he volunteered in the Tel Dan excavations, Israel. After receiving a Bachelor of Arts degree in Near Eastern and Classical Studies at Hampshire College in 1980, he travelled extensively in Europe and the Near East. In the fall of 1981 he entered the Graduate College of Texas A & M University to study nautical archaeology in the Department of Sociology and Anthropology. During the summer of 1982 he studied Arabic at the Johns Hopkins School for Advanced International Studies in Washington, D.C. In November of 1983 he married Cheryl Anne Ward. He has assisted with excavations, surveys and artifact conservation in Bodrum, Turkey, learned shipbuilding techniques at the Apprenticeshop in Bath, Maine, and served as deckhand on board the schooner Victory Chimes. His permanent address is 329 Mansion Drive, Alexandria, Virginia 22302.