

THE ATHLIT RAM: CLASSICAL AND HELLENISTIC BRONZE CASTING
TECHNOLOGY

A Thesis

by

ASAF ORON

Submitted to Texas A&M University
in partial fulfillment of the requirements for the degree of

MASTER OF ARTS

Approved as to style and content by:

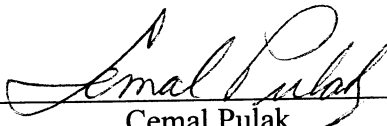

Cemal Pulak
(Chair of Committee)



Donny Hamilton
(Member)

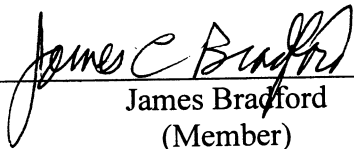

James Bradford
(Member)



David Carlson
(Head of Department)

December 2001

Major Subject: Anthropology

ABSTRACT

The Athlit Ram: Classical and Hellenistic Bronze Casting Technology.

(December 2001)

Asaf Oron, B.Sc., University College London

Chair of Advisory Committee: Dr. Cemal Pulak

In 1980 a warship ram of bronze was discovered at Athlit Bay, south of Haifa, Israel. The subsequent study of the ram added significantly to the knowledge concerning Classical and Hellenistic large-scale bronzes. The Athlit ram far exceeds other existing rams in size and is one of the largest bronzes to have survived intact from the ancient Mediterranean world. Initial metallographic and metallurgical analyses of the ram, made shortly after its recovery, led to the conclusion that it was cast horizontally as a single piece in a two-part sandbox. However, the use of this casting method, commonly referred to as sand-casting, has not been documented prior to the late Medieval period. Such a conclusion is therefore inconsistent with existing knowledge of Classical and Hellenistic bronze casting technology.

Through the use of advanced analytical techniques and careful visual examination, the current study re-evaluates the technology employed in casting the Athlit ram. Newly gathered data, complemented with archaeological evidence from foundry remains and other surviving bronzes, indicate a close technical correlation between the methods used to produce the ram and the techniques used to create contemporary bronze sculptures. With reference to ancient literary sources and modern technical studies, the current work attempts to reconstruct the casting sequence used. The conclusions place the Athlit ram comfortably within the known parameters of Classical and Hellenistic foundry practices. This study suggests that the ram was cast using the lost-wax technique and speculates about the adaptation of this casting method in order to use the bow timbers of the ship as a temporary core on which to build the wax model, thereby more efficiently fulfilling the design requirements of the ram.

*To Erkut,
friend, diver, and scholar
(1971-2001)*

“The examination of the technical processes involved in the realization of these objects is fundamental to their full appreciation. Certainly a deeper understanding of the techniques of making, repairing, and finishing a work lends a whole new dimension to the aesthetic of the piece, a dimension that stems, quite simply, from a delight in workmanship, in manual skill and dexterity.”

Lechtman and Steinberg, *Bronze Joining:
A Study in Ancient Technology*

ACKNOWLEDGMENTS

Every long journey starts with one small step... In this case, it was an idea put forward to me by Dr. William Murray over a glass of *raki* after a day's work at the excavation site at Tektaş Burnu in June 1999. Two additional seasons working together in this magnificent setting provided further opportunities for numerous discussions and fresh ideas as my work on the ram progressed. I am thankful to Dr. Murray for introducing me to this fascinating object and for his help and encouragement throughout my study.

The study of the ram would not have been possible without the kind permission of Professor Elisha Linder and a permit generously provided by the Israeli Antiquities Authority to conduct the necessary tests. I am most grateful to both.

My gratitude is also extended to Dr. Avshalom Zemer, Director of the National Maritime Museum in Haifa, and his staff for their warm welcome and assistance during long hours of work at the museum

The study of ancient technology and the interpretation of works of art is a multidisciplinary field involving a diversity of expertise rarely found in a single individual. I would like to thank Dr. Mathew Ponting for his help with the metallographic and chemical analysis, Dr. Joseph Shoef and his team for conducting the radiographic work, Mr. Kelly Duggan for digitizing and processing the X-ray negatives, Dr. Ray Guillemette for conducting the electron microprobe work, and Dr. Yuval Goren for his help with petrographic analysis. Thanks are due also to Mr. Dick Stone of the Sherman Fairchild Center for Objects Conservation at the Metropolitan Museum of Art, and Mr. Dick Steffy of the Institute of Nautical Archaeology for their insights. Special thanks go to Annette Schreur for her endless help with the drawings and her patience throughout.

I am particularly grateful to the Institute of Nautical Archaeology for sponsoring my research and to the faculty and staff of the Nautical Archaeology Program for their help and support.

I would like to acknowledge the members of my graduate committee- Dr. Cemal Pulak, Dr. Donny Hamilton, and Dr. James Bradford- for their guidance and patience during the writing of this thesis.

To all my friends, a fine network of dedicated people connected by a common journey of past memories and future dreams, by electronic mail and late night long-distance phone calls, my heart and thanks are with you.

Finally, and most of all, I would like to thank my parents. In a constantly changing reality and through my transitions from one continent to another, their patience and endless loving support is my greatest source of strength and inspiration.

TABLE OF CONTENTS

	Page
ABSTRACT.....	iii
DEDICATION.....	iv
ACKNOWLEDGMENTS.....	v
TABLE OF CONTENTS.....	vii
LIST OF TABLES.....	ix
LIST OF FIGURES.....	x
CHAPTER	
I INTRODUCTION.....	1
II TECHNOLOGY OF BRONZE CASTING IN THE ANCIENT GREEK WORLD.....	8
Origins and Development.....	8
Early Bronze Casting and the Origins of Hollow Casting.....	9
The Lost-Wax Technique in Its Direct and Indirect Forms.....	11
Casting Installations.....	19
Mold Bases and the Orientation of the Mold during Casting.....	21
Post-Casting Work.....	22
III CLASSICAL AND HELLENISTIC COPPER ALLOYS.....	28
Copper-Tin Bronze.....	29
Leaded Bronze.....	29
Brass.....	31
Alloys and Alloying Practices: Literary Evidence.....	31
Analytical Evidence.....	34
IV LARGE SCALE BRONZE CASTING IN THE ANCIENT WORLD.....	39
Archaeological Evidence.....	40
Literary and Iconographic Evidence.....	42

CHAPTER	Page
V THE ATHLIT RAM: DESCRIPTION AND OBSERVATIONS.....	46
General Description.....	46
Decorations.....	51
Wall Thickness.....	55
Fin Channels.....	60
Chaplet Holes.....	62
Surface Quality.....	65
Evidence of Use, Casting Faults and Repairs.....	65
VI THE CASTING OF THE RAM: DISCUSSION.....	72
Possible Production Methods.....	73
Rams and Bows.....	78
Additional Evidence for the Use of the Direct Process.....	85
Casting the Ram: Reconstruction.....	87
VII CONCLUSIONS.....	91
WORKS CITED.....	95
APPENDIX A CHEMICAL ANALYSIS OF THE ATHLIT RAM.....	104
APPENDIX B RADIOGRAPHY.....	113
APPENDIX C CHEMICAL ANALYSIS OF CORROSION FROM THE RAM'S CAVITY.....	119
APPENDIX D DRAWINGS.....	125
APPENDIX E RADIOGRAPHIC PHOTOMOSAICS.....	126
APPENDIX F DISTRIBUTION OF CHAPLETS VISIBLE ON RADIOGRAPHS OF THE RAM.....	130
APPENDIX G LETTERS OF PERMISSION AND COPYRIGHTS.....	131
VITA.....	134

LIST OF TABLES

TABLE	Page
1. Analysis of Greek statuary bronzes.....	37
2. Thickness of Greek statuary bronzes.....	38
3. Eagles: distance between points end elevation measurements.....	52
4. Pilei: distance between points end elevation measurements.....	53
5. Handle Devices: distance between points end elevation measurements	54
6. Actium War Memorial ram sockets grouped according to 'wale-ramming timber unit size'.....	80
7. Chemical composition of metal samples from the Athlit ram.....	107
8. 'Base' composition of the ram.....	108
9. Chemical composition of metal samples removed from repaired areas.....	110
10. Total dosimeter readings at the end of each working day.....	117
11. Summary of exposures throughout the radiography campaign.....	117
12. Quantitative analyses in weight percent, at the approximate locations A, B, C, D.....	122

LIST OF FIGURES

FIGURE	Page
1. The find location of the Athlit ram.....	2
2. The Athlit ram on display at the National Maritime Museum, Haifa, Israel.....	3
3. Survey platform in use.....	7
4. Hollow casting by the direct method.....	12
5. Hollow casting by the indirect method.....	12
6. Casting-pit on the west slope of the Areopagus.....	20
7. A reconstruction of a ram casting-pit in operation.....	20
8. Enlarged surface area along a fusion weld join.....	25
9. The application of a bronze patch to an undercut bed over a faulty surface.....	25
10. Phase diagram of a copper-tin alloy system.....	30
11. The effect of the addition of tin to copper on the hardness after cold working.....	30
12. Identification of the ram areas.....	47
13. The two pairs of protrusions on the bottom plate.....	50
14. Plaster mold fragment from the Cairo Museum.....	56
15. Cowl ceiling and bottom plate wall thickness.....	56
16. Transverse mark on the bottom plate and sides of the ram.....	58
17. Oblique marks merging into the bottom plate channel.....	58
18. A view of the bottom side of the ramming timber.....	59
19. Surface irregularity on the port trough sideplate.....	59
20. The interior of the sideplates showing the arrangement of the fin channels and their asymmetric nature.....	61
21. Repair patch over a chaplet hole on the ram.....	63
22. Variations in surface quality at the area of the ramming head.....	66
23. Casting faults repaired with patches.....	68
24. Cast-on repair on the starboard tip and border of the cowl, seen from the exterior and interior surfaces.....	70

FIGURE	Page
25. The repaired tailpiece join.....	70
26. The original timber arrangement within the Athlit ram.....	84
27. Sampling locations for ICP-AES analysis.....	106
28. Difference of individual bulk samples from the ram 'norm'.....	111
29. Difference of repairs and unusual samples from the ram 'norm'.....	111
30. Calculation of distance of collimator to x-ray film.....	114
31. Cross-sectional views of polished crust sample obtained as BSE.....	121
32. Plotted values of EDS qualitative analysis.....	122
33. BSE image of individual elements.....	123
34. Composite, false-color x-ray map.....	123

CHAPTER I

INTRODUCTION

Pliny's description of various centers of the Greek world suggests that sanctuaries and marketplaces were crowded with hundreds, if not thousands, of large bronze statues.¹ However, for reasons that include the scarcity and high value of bronze, its usefulness for machines of war, and its ability to be easily remelted, few ancient bronzes have survived. Close examination of the few existing examples provides a glimpse into the techniques involved in their manufacture and adds a significant chapter to the history of metalworking in the ancient world.

The discovery of an intact warship ram of bronze in November 1980, at Athlit Bay, 10 km south of Haifa, Israel, (fig. 1) has added significantly to the knowledge of existing Classical and Hellenistic large-scale bronzes. The ram is one of the largest bronzes to have survived intact from the ancient Mediterranean world and is the only large ancient warship ram ever found (fig. 2).² Furthermore, its use as an impact weapon places it in a unique position among other contemporary bronzes, as it is the only extant large cast bronze made for practical, rather than decorative, use.

A naval ram is a forward-projecting structure mounted on the bow of a warship designed to inflict structural damage on an enemy vessel. Common warships often carried a primary ram (*embolion*) and one or more secondary rams (*proembolion*).

This thesis follows the format of the *American Journal of Archaeology*.

¹ Plin. *NH.* 34.35-48.

² In addition to the Athlit ram, five separate artifacts have been identified as either *embolia* (primary rams) or *proembolia* (secondary rams). These are: the ram in the Kanellopoulos Museum (Brouskare 1985, 46; Calligas 1996, 129-41; Pridemore 1996, 101-6, fig. 39); the Turin ram (Torr 1964, pl. 8, fig. 43; Pridemore 1996, 99-100); the ram in the Fitzwilliam Museum weighing 19.7 kg (Basch 1987, 408, figs. 866-7; Pridemore 1996, 74-98, figs. 26-30); the Bremerhaven ram weighing 53 kg (Murray 1991a, 75, fig. 5; Pridemore 1996, 63-74, figs. 22-4; additional views of this ram appear in the Galeria Nefer's sales catalogue (1987, 25); and, the Piraeus ram (Stainchauer 1998, 30-1, pl. 1). A small ram fragment weighing 6.5 kg was recently discovered at the Actian war memorial at Nikopolis (W.M. Murray, pers. comm., 2001); Konstantinos 2001, 39). It appears to be part of the ramming head area. Unfortunately, none of these finds have been the subject of technical studies and, consequently, their potential contribution to the current study could not be fully realized.

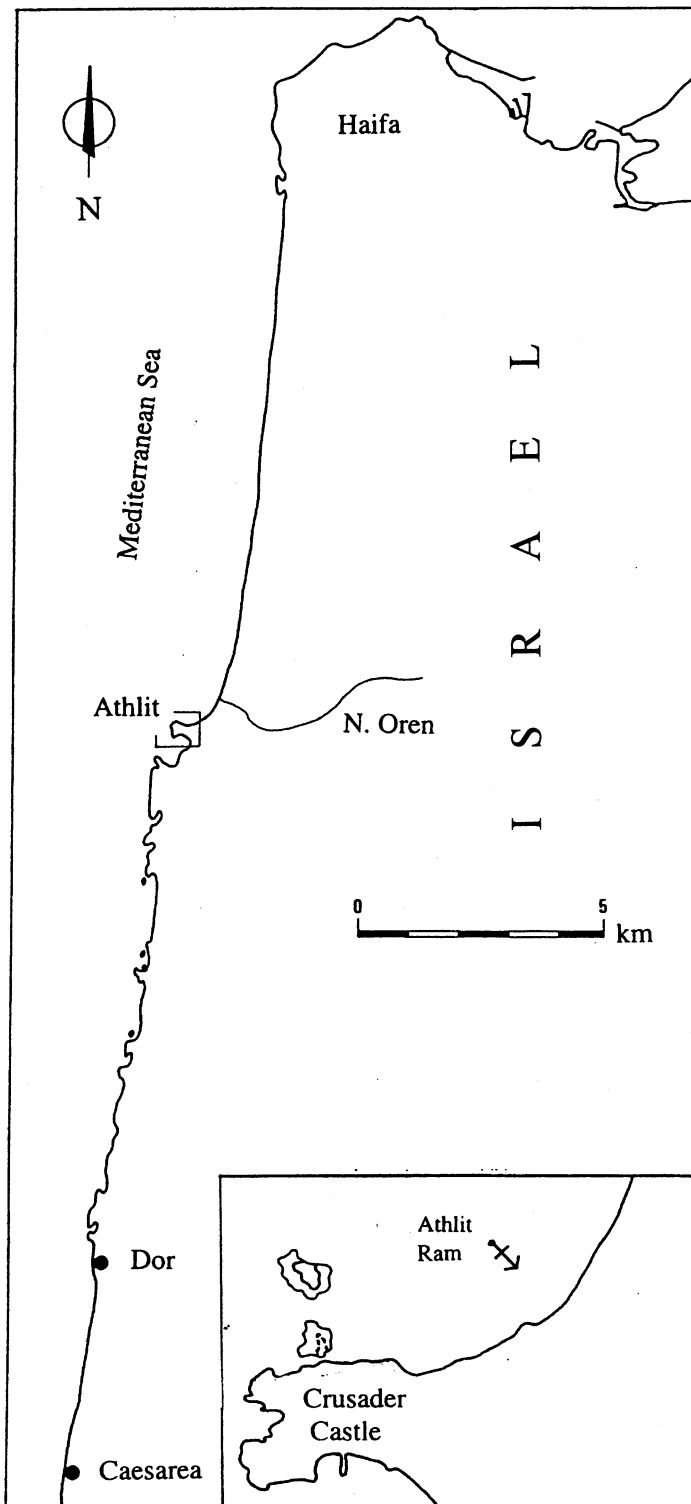

Fig. 1. The find location of the Athlit ram. (After Linder 1991, fig. 1.1)

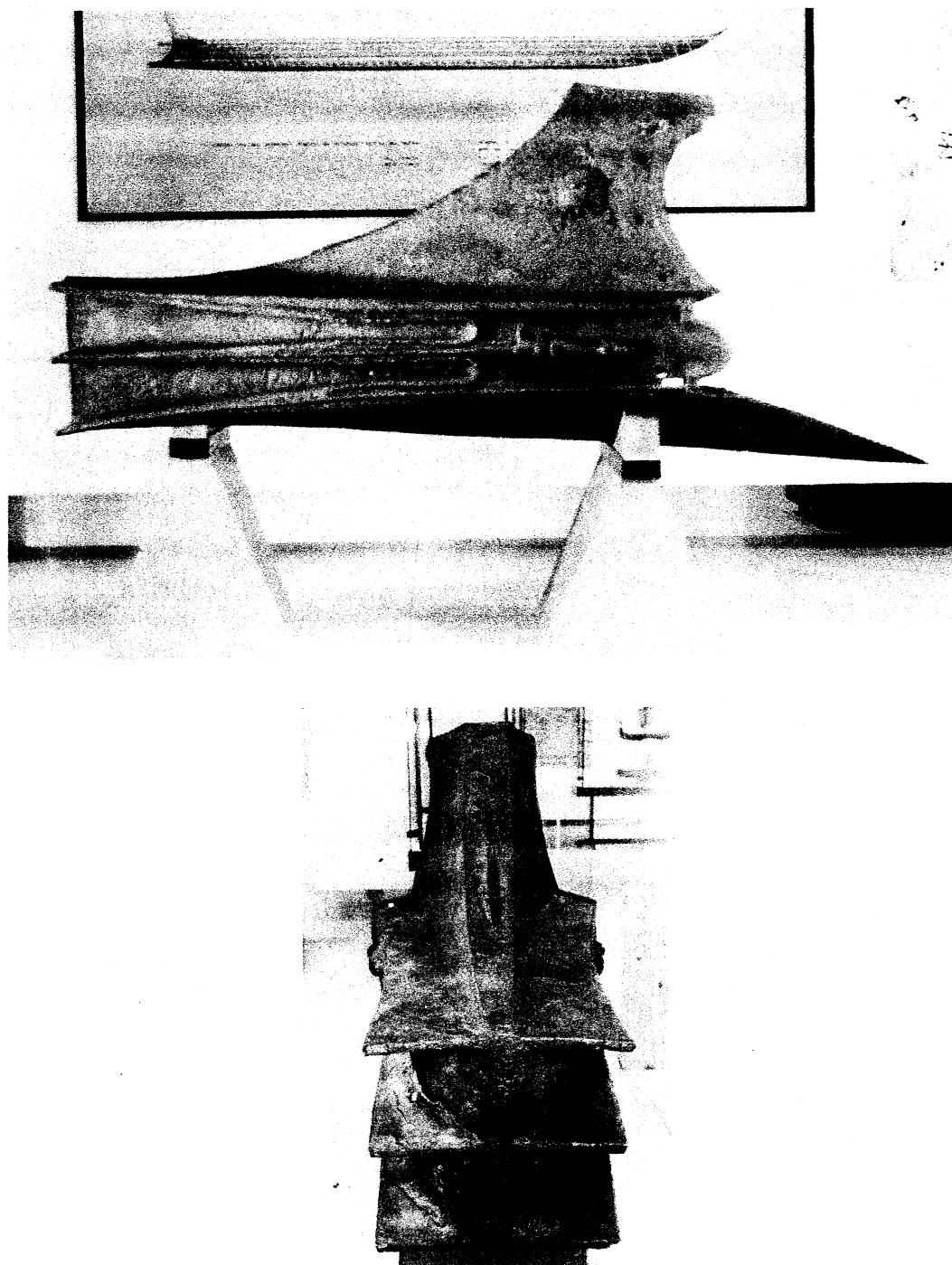

Fig. 2. The Athlit ram on display at the National Maritime Museum, Haifa, Israel.
(Photograph by the author)

The primary ram was located at the vessel's waterline. Its main function was to be driven against the hull or oars of an enemy ship.

Available evidence suggests that the most probable date for the first appearance of a warship equipped with a ram in Greek waters is about 900 B.C.³ Its appearance had a revolutionary impact that has been compared by Casson to that of the introduction of the naval gun some twenty-five hundred years later.⁴

Symbols molded on the surface of the Athlit ram suggest that it was cast on Cyprus for the Ptolemaic fleet stationed there in the late third century or early second century B.C.⁵ The ram is 2.26 m long, 0.95 m high, and weighs 465 kg. Together with the bow timbers preserved within it, the Athlit ram provides a rare opportunity to study both the technology of bronze casting and methods used in warship construction during the Hellenistic period.

Detailed analysis of the ship's scantily preserved bow timbers, found inside the ram, has led to a revision of our understanding of ancient technology and the concepts behind the construction of war galleys, the premier naval weapons of their time. The study of the Athlit ram has shown that the ship functioned as an extension of the ram during impact, and provided the necessary momentum to impart maximum damage, as well as to dissipate the immense forces generated. The ram itself was designed to split and to crush, rather than to penetrate, the enemy vessel, since the latter category of damage could more easily be repaired after the ramming ship retreated.⁶

Initial metallographic and metallurgical analyses of the ram undertaken at Haifa University suggested that it was cast horizontally as a single piece in a two-part sandbox, with a clearly defined parting line.⁷ However, this casting method, often referred to as sand-casting, is not otherwise encountered in the casting of fine objects prior to the late

³ van Doorninck 1982, 285.

⁴ Casson 1971, 49.

⁵ Murray 1991a, 51-66.

⁶ Steffy 1991, 38; Casson and Linder 1991, 68.

⁷ Eisenberg 1991, 40-50.

Medieval period.⁸ Such a conclusion, therefore, contradicts current knowledge of Classical and Hellenistic bronze casting technology. This knowledge is based on considerable archaeological evidence, including foundry remains, mold fragments, casting-pits, and contemporary large bronzes. The evidence consistently points to the use of clay-based materials for mold making and casting of both small and large bronzes by the lost-wax technique.⁹ Moreover, large bronzes were cast vertically rather than horizontally, a practice that continued into early modern times in the manufacturing of bronze cannon.¹⁰

It seems, then, that the initial interpretation of the casting of the ram was based primarily on a knowledge of relatively modern foundry practices, and less so on the available current body of archaeological and historical evidence for ancient metalworking techniques. In light of such conflicting conclusions, a thorough re-evaluation of the ram was considered necessary. A more accurate reconstruction of the technology behind the Athlit ram has important implications not only for our understanding of Hellenistic naval power, but also for the history of bronze technology in the ancient world.

The primary goal of this study is to re-examine in detail the technology used to cast the ram by means of advanced analytical techniques. Some of the methods are new to the study of the ram, while others were employed previously but have been modified to yield improved results. The methods used in the current study include chemical analyses by inductively-coupled plasma atomic emission spectrometry (ICP-AES), electron microprobe and energy dispersive X-ray spectrometry (EDS), metallographic examination of cross sections, and radiography.

⁸ Maryon 1956b, 475. Open sand molds may have been used for the casting of crude objects such as copper and tin ingots during the Late Bronze Age (van Lokeren, 2000, 275).

⁹ Haynes 1992, 54-5; Mattusch 1994, 789. See Mattusch (1990, 125-6) for a concise review of the evolution of ideas leading to the current acceptance of the lost-wax technique as the primary method in use throughout the Greek world.

¹⁰ Biringuccio 1943, 259-60.

Since the initial study of the ram was conducted prior to its final conservation and the removal of the hull timbers preserved within, only the most obvious surface details on the exterior were recorded. With the ram now fully cleaned and the hull timbers completely removed, it was possible for the first time to visually examine all of its surfaces, including the interior of its cavity. In order to examine the interior surface of the ram, a portable survey platform was designed to move one person into and out of the cavity (fig. 3).

The re-examination of the Athlit ram produced a wealth of new information, which was used to re-evaluate its casting technology and to elucidate its sequence of production. The data collected during this work is presented alongside the archaeological records available for other contemporary bronzes and foundry sites. By drawing parallels between these, as well as through the use of relevant literary, iconographic, and historic sources, this research examines the position of the Athlit ram within the context of ancient metalworking traditions and, more specifically, its relation to Classical and Hellenistic foundry practices.

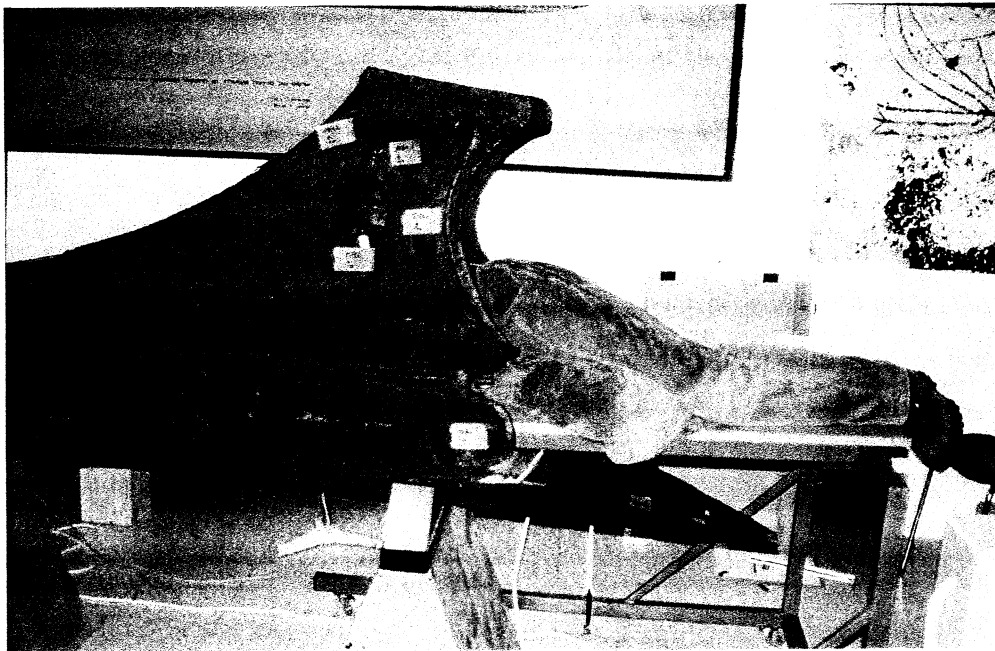
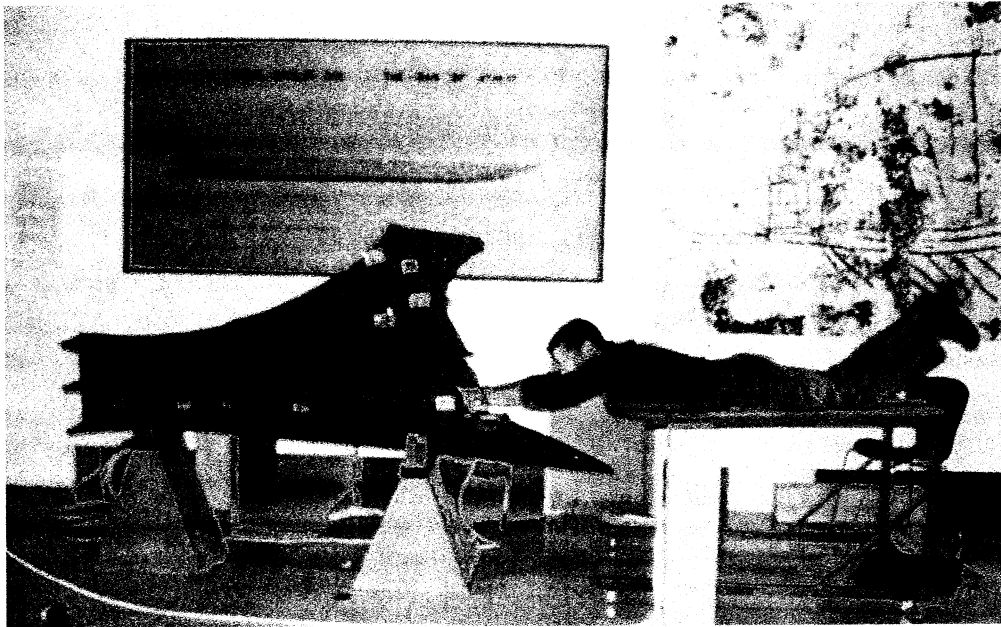

Fig. 3. Survey platform in use. (Photograph by the author)

CHAPTER II

TECHNOLOGY OF BRONZE CASTING IN THE ANCIENT GREEK WORLD

The development of casting technology is one of the principle features of bronze working during the Classical and Hellenistic periods. The reconstruction of the methods used by the Greeks to cast large bronzes is based primarily on the archaeological record, which includes surviving statuary, foundry sites and casting debris, as well as a few vase paintings representing activities connected with casting. However, since the archaeological evidence is rarely self-explanatory, its interpretation is aided by studying all possible technical options discussed by Classical, Medieval, Renaissance, and modern authors writing on technical aspects of foundry practices. Taken as a whole, these point to the widespread use of the lost-wax casting technique as the principle method by which large and small bronzes were produced in ancient Greece.¹¹

Origins and Development

The first bronze figures in Greek art, according to Pausanias were made using the *sphyrelata* method, a technique based on the construction of a single object out of one or more metal sheets hammered to shape and joined together with rivets.¹² This technique was in use until the invention of bronze casting on Samos: "The first men to melt bronze and to cast images were the Samians Rhoikos, the son of Philaeus, and Theodoros, the son of Telekles."¹³ The archaeology of Greece, in particular the excavation of Olympia, confirms the chronological sequence suggested by Pausanias. It shows that the first large bronze statues, appearing during the eighth century B.C., were made of hammered

¹¹ Mattusch 1994, 789; See also Mattusch (1990, 125-6) for a concise review of the evolution of ideas leading to the current acceptance of the lost-wax technique as the primary method used throughout the Greek world.

¹² Paus. *Description of Greece* 3.17.6.

¹³ Paus. *Description of Greece*, 8.14.5-8.

bronze sheet.¹⁴ It was not until the middle of the sixth century B.C. that large cast bronzes started to appear in Greece, that is to say bronzes of about one-third life size or larger.¹⁵ However, Pausanias' statement that the two Samians were the first men to melt bronze and cast images cannot be taken at face value, since the technique of melting and casting bronze in Greece predate Rhoikos and Theodoros, who lived during the first half of the sixth century B.C.¹⁶ In fact, bronze casting was known to the Greeks beginning in the Bronze Age, and the casting of small bronze statues and tripods is characteristic of Geometric art of the eighth century B.C.¹⁷ It is therefore suggested that in his statement Pausanias did not intend to say that bronze casting was invented by Rhoikos and Theodoros, but that these two were the first to cast large bronze statues, i.e., those life size or larger.¹⁸

It is generally accepted that the Greeks learned the technique of complex hollow bronze casting from the cultures of the Near East, in particular Egypt. The founding of Naukratis, an important trading port for many of the eastern Greek city-states, in the Nile Delta in 650 B.C. provided ample opportunity for exchange of knowledge and skills between the two cultures. Samos seems to have made a particularly active contribution to this Greco-Egyptian exchange, as indicated by the large number of Egyptian artifacts excavated at the Heraion of Samos, among which are examples of Egyptian hollow-cast bronzes.¹⁹

Early Bronze Casting and the Origins of Hollow Casting

Early cast-bronze figures in Greece emerged from a tradition of casting small scale bronzes. The earliest bronze figurines, dated typologically to the middle or second half of the 10th century B.C., are solid casts depicting a nude male with outstretched

¹⁴ The earliest surviving examples of Greek sphyrelata are the figures of Apollo, Artemis, and Leto found at Dreros on Crete. The figures are currently dated to the late eighth century B.C. (Romano 1980, 288)

¹⁵ Haynes 1992, 11.

¹⁶ Haynes 1992, 48.

¹⁷ Mattusch 1988, 31; see also Rolley 1986, 59-64; Snodgrass 1971, 281-4.

¹⁸ Kyrieleis 1990, 15-6.

¹⁹ Kyrieleis 1990, 24-5; Mattusch 1988, 46-50; Bianchi 1990, 74-7.

hands. These were followed in the Geometric period by charioteers that demonstrate further development in modeling and molding.²⁰ These early bronzes were sometimes modeled in wax, on a wedge of clay, and then invested and fired as in the case of Geometric horses. The molten wax ran out of the mold and the bronze was poured in around the wedge, which was later scraped out, leaving the characteristic open hollow on the underside.²¹

During the eighth and seventh centuries, a time of increasing ties between the Greek world and the eastern Mediterranean, new types of bronzes and new techniques for manufacturing them began to appear in Greece. Of major importance during this time was the development of hollow casting techniques in Greece. Hollow casting is based on the principle of using a clay core over which the wax model is formed. Thus, when a wax model is invested in clay and fired, the wax pours out leaving the clay core, which is fixed to the mold walls with pre-positioned copper or iron rods known as chaplets. Variations in this method lead to the clay core being either completely encapsulated in the finished cast or otherwise only partially covered, in which case it could be scraped out, leaving behind an empty cavity.²² The evolution of hollow-casting techniques is best seen in the development of the griffin protomes attached as ornaments to the rim of bronze votive cauldrons. Earlier examples of griffin-protomes are made of hammered bronze sheets in accordance with the sphyrelata tradition. During the seventh century, the hammered protomes were replaced by cast ones.²³ However, if made of solid bronze, a protome would have required a large amount of metal and would have resulted in an object that was too heavy to be fixed safely to the thin metal cauldrons.²⁴ By using a clay core during the casting process, it was possible to produce a light and thin-walled casting suitable for mounting on the cauldrons. The development of the hollow-casting technique allowed the casting of increasingly larger hollow bronzes from

²⁰ Rolley 1986, 61; Mattusch 1988, 32-4.

²¹ Maryon 1956b, 476.

²² Craddock 1977, 103-4.

²³ Mattusch 1988, 47.

²⁴ Kyrieleis 1990, 19.

the seventh century onwards and eventually led to the virtual abandonment of the sphyrelata technique.

The Lost-Wax Technique in Its Direct and Indirect Forms

The lost-wax technique is most often divided into two main categories: the direct method and the indirect method. If the model (i.e., the original object or figure prepared by the bronze caster) is destroyed in the course of being transformed into bronze, the resulting piece is described as a direct cast. If the model is preserved, normally by the use of molding techniques, the piece is described as an indirect cast. The principle stages of production in each method are summarized in figures 4 and 5.

Direct Casting

In the simplest form of the direct casting process, the bronze caster starts with a solid model slightly larger than the finished object he wishes to produce, in order to allow for the 1.5% shrinkage characteristic of most alloys of copper.²⁵ The model was most often made of beeswax, a universally available medium of good plastic qualities.²⁶ Once completed, the model had to be provided with gates (also referred to as jets) and vents. Gates are the channels through which the metal is poured into the mold. To avoid turbulence during this operation, they are usually designed to fill the mold from the bottom. Vents are channels through which the air displaced and the gasses generated during the pour can escape as the metal fills the mold. In a simple mold, these could be made from terracotta tubes attached to the mold after it had been baked, by boring holes and fixing the tubes to them.²⁷

²⁵ Stone (1982, 89) indicates that a linear contraction of 1.5% is equivalent to 3/16 of an inch per foot.

²⁶ Cavanagh (1990, 148) notes that for centuries beeswax has been the preferred modeling material due to its superior qualities. Although there are no physical remains of modeling wax from antiquity, its use is known from drip marks and joining marks found inside many Classical and Hellenistic statues. Wax is mentioned, along with other casting supplies such as copper, clay and hair, in line 105 of the fragmentary accounts of the construction of the Athena Promachos, *IG I³* 435.10-13 (restored), 42-5 (restored), 69-72 (restored), and 101-5.

²⁷ In describing the lost-wax technique, Biringuccio (1943, 230.) says that the holes are bored for the vents and gates in the completed mold before it is baked.

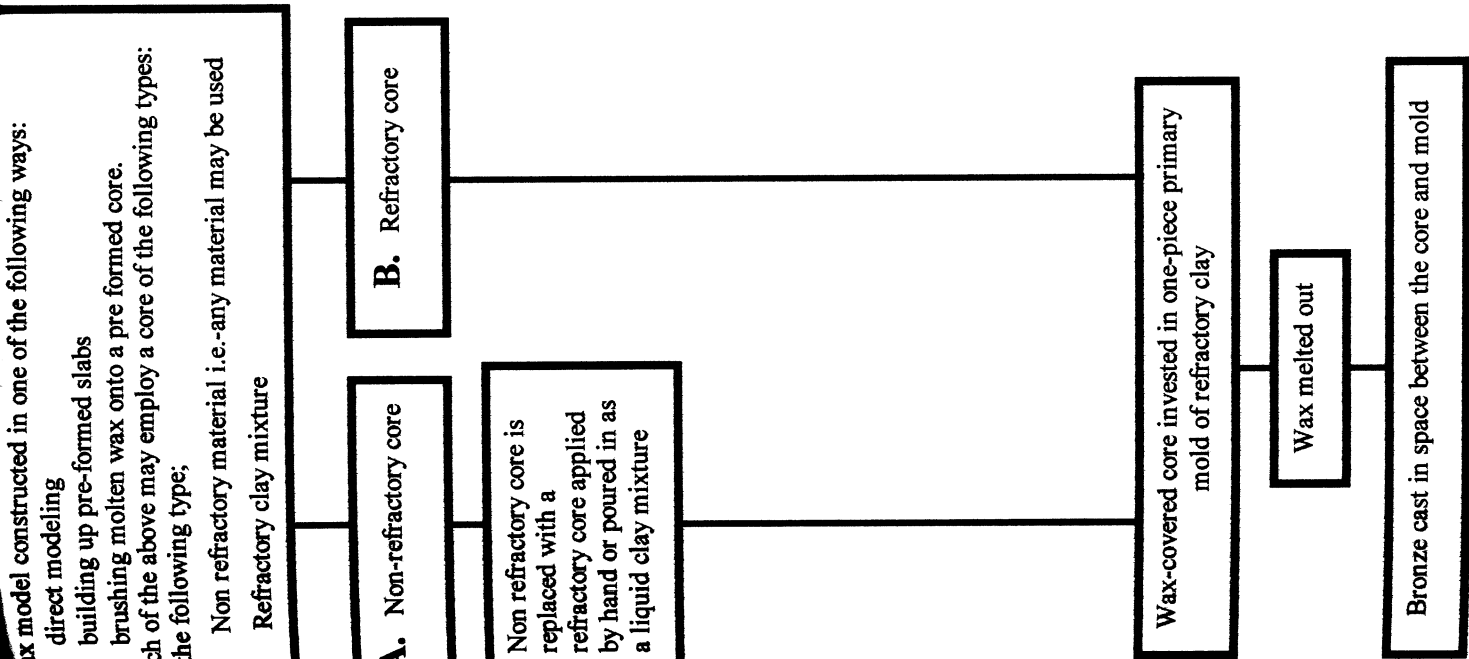

Fig. 4. Hollow casting by the direct method.

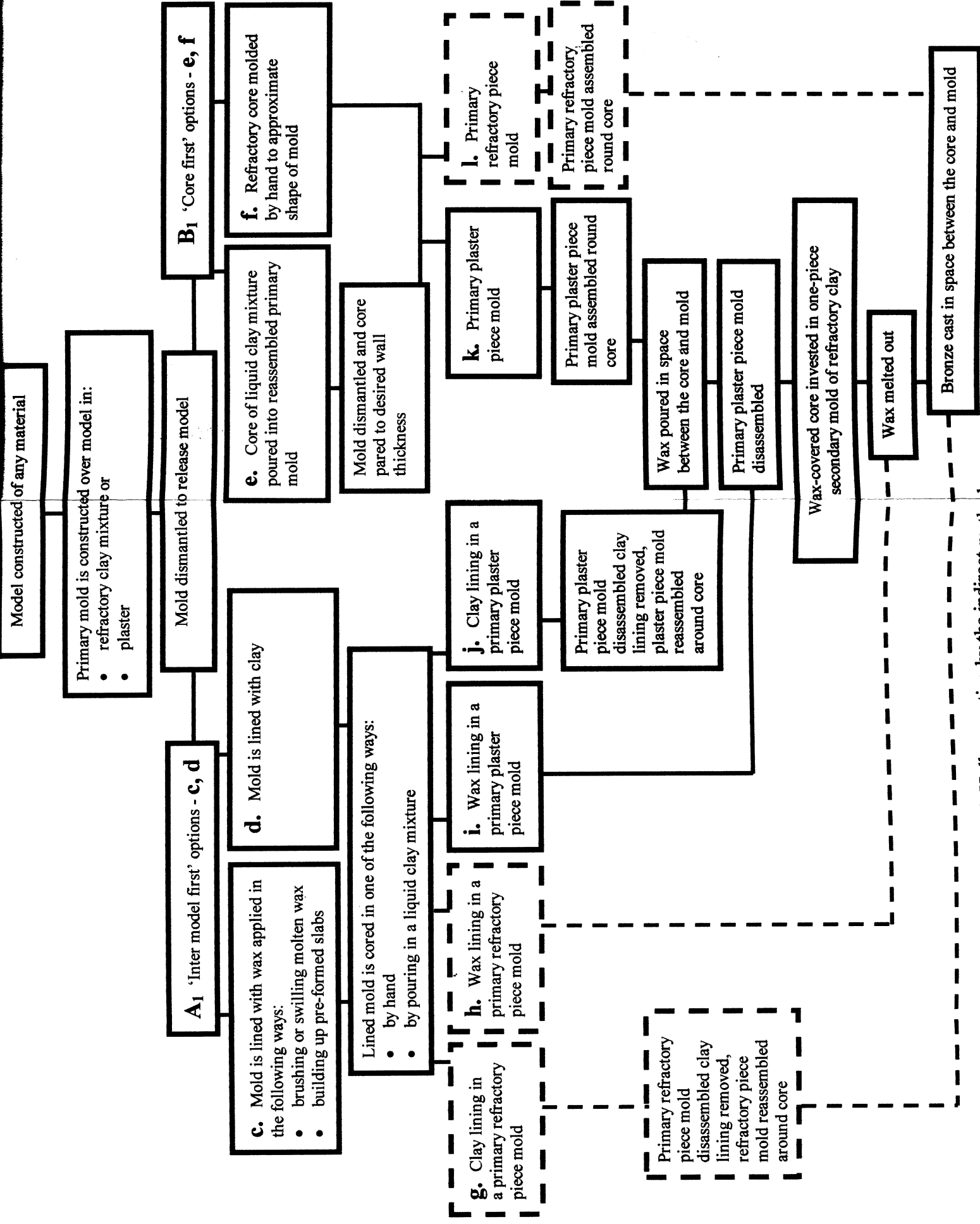

Fig. 5. Hollow casting by the indirect method.

A more convenient way to form gates and vents is to shape them with wax rods and affix them to the wax model before the investment process. Evidence for the use of the latter method in antiquity is seen in gates and vents found in a fourth-century B.C. casting-pit at the Athenian Agora. Most of these have a smooth and regular interior suggesting that they were formed over wax patterns.²⁸ Since the gates sometimes appear alongside a mold surface surrounded by the same layers that form the mold, it is clear that they were constructed entirely in wax and attached to the wax model directly.²⁹ Most of the gates from the Agora are round in section and range between 0.8-2.0 cm in diameter. The vents were also more or less circular, but their average diameter was about half of that of the gates.³⁰ Once finished, the model was covered with a refractory clay mixture to form an investment mold. Greek statuary mold fragments found in Olympia (fifth century B.C.) are normally composed of two main layers.³¹ The inner layer is made of fine hard clay applied in the form of slip with a brush. The outer layer is made of coarser clay containing a mixture of sand, gravel, and seashells to reduce shrinkage, and also combustible organic material, such as straw and hair, included to increase porosity. The average thickness of Greek molds is 3.5 cm. Despite their thinness, there is no evidence that they were ever reinforced. This seems surprising since Medieval, Renaissance and modern molds are often reinforced with iron straps or ribs.³²

When the clay mold had dried, it was positioned in the casting-pit and fired. Casting installations will be discussed in detail in a later section. Firing accomplishes two things: first, it melts away the wax model and burns out any wax remaining inside the mold; second, it further dries and hardens the clay shell. Immediately following firing, while the mold is still hot, the casting-pit was packed with sand and the mold was filled with molten bronze. After cooling, the mold was broken to release the cast, which

²⁸ Mattusch 1977, 351, pl. 83.

²⁹ Mattusch 1977, 352, pl. 84.

³⁰ Mattusch 1977, 351

³¹ Schneider 1989, 18; Clay and hair are listed in the accounts on the making of the Athena Promachus in the fragmentary accounts of the construction of the Athena Promachus, *JG I*³ 435.10-13 (restored), 42-5 (restored), 69-72 (restored), and 101-5.

³² Biringuccio 1943, 258.

was an exact replica of the wax model, although slightly smaller due to the contraction of the bronze. This simple form of direct lost-wax casting produced a solid cast. If applied to a large object, it was costly and resulted in an extremely heavy casting that was physically unsound due to the uneven contraction of adjacent areas with widely differing masses. Therefore, with few exceptions, this method has been used primarily in the production of relatively small objects.

In order to cast larger bronzes, it was necessary to introduce a core into the mold, so that when the bronze was poured, it was confined to the space between the core and the investment, producing a hollow cast. The simplest way to produce a hollow cast is by forming the wax model around a preformed refractory core made of clay (see fig. 4). The core can vary from a crude mass whose only function is to displace metal, to a reduced replica of the model. The more closely the core was constructed to fit the size and shape of the finished work, the thinner and more uniform the wax layer and the resulting bronze cast would be. To prevent the clay from shrinking and cracking as it dried, it was common practice to mix it with sand and organic materials such as cloth clippings, straw, dung, and hair. When the core was baked, these components were burned out, creating a network of fine vents through which the gases generated during casting could disperse.³³ For further ventilation of the core, the bronze caster could include a length of rope or other combustible materials to form an airway leading to the exterior.³⁴

Once the core was thoroughly baked, thereby eliminating any trace of moisture, it was covered with a layer of wax, applied as a paste by brushing on several layers or as solid slabs. The wax layer was built to the desired wall thickness of the final cast.

³³ Lombardi (1998, 1056-7) identified animal hair and vegetal fiber inclusions in the cores of the Riace statues. Biringuccio (1943, 231) recommends mixing the liquid clay of the core with cloth clippings, horse dung, the ashes from half of a young ram's horn, and a little fresh plaster of Paris.

³⁴ Haynes 1992, 25.

After the completion of the wax model, the bronze caster would normally retouch the model using hot spatulas or even rasps to eliminate marks such as seam lines and brush marks.³⁵ As will be seen later in this study, construction marks left untouched in unreachable areas such as the interface of the model and the core in the bronze's interior often provide the modern researcher with valuable information regarding the object's technical history.

Once completed, the model was pinned to the core with chaplets, with only their aft ends protruding above the surface to be embedded in the investment mold. The purpose of the chaplets was to hold the core in place once the wax was melted out and to prevent it from floating in the molten metal during casting.

Due to the density of bronze (approximately eight times greater than water) considerable force is exerted on the core by its buoyancy in the liquid metal. The chaplets must be sound enough to resist this force at the high temperature of molten bronze.³⁶ Chaplets may be made of either iron or bronze; however, it seems that most Greek bronzes were cast with iron chaplets and that the chaplets used were normally rectangular in cross section.³⁷ After casting, the iron chaplets were pulled out, leaving characteristic rectangular holes in the walls of the object that were normally covered with bronze patches. Chaplet holes are easily recognized in the radiographic images of many ancient hollow-cast bronzes, and appear as low density rectangular marks.³⁸ In cases where the iron chaplets were not removed after the cast, they are often visible on the surface of the bronze as reddish rectangular blemishes of corrosion. Once the core

³⁵ Biringuccio (1943, 231) describes the cleaning of wax webs, left on the inter model by the mold sections parting lines, before the model was invested.

³⁶ Stone 1982, 91, n. 16.

³⁶ Craddock (1977, 103) observed copper or bronze pins inside a damaged Classical statuette. Biringuccio (1943, 228) suggested the use of hammered bronze rods as chaplet material.

³⁷ See Mattusch (1988, 225) for a list of archeological finds of iron chaplets and chaplet impressions in core remains and mold fragments. The use of bronze chaplets may have been less favored due to their closer melting point to the casting metal and the risk that they would fail during the casting.

³⁸ See Ridgway (1987, figs. 5.66-7, 5.69) for examples of square chaplet holes in bronze statue fragments, and Willer (1994, 964, fig. 1) for a radiographic image of a square chaplet hole in the surface of a bronze Herm.

was secured, the model was invested and the casting process proceeded in the same sequence described earlier under the simpler form of the direct casting method.

Figure 4-A postulates a variant of the direct casting process that played an important role in the interpretation of the casting of the Athlit ram. In this sequence, the wax model can be built on any preformed feature, including those of non-refractory materials, that served as a temporary core. The method will work as long as the core can be withdrawn from the model and replaced by a secondary core of refractory clay. The primary advantage of this technique is its ability to allow the bronze worker to make a cast that can fit precisely onto an existing structure. The method could have been used in the making of cast-bronze fittings for wooden furniture, architectural elements, and possibly bow ornaments and naval rams.³⁹

Indirect Casting

The indirect casting process uses molding techniques such as piece molding to replicate the model. A piece mold is an exact negative of the original produced by dividing the model into sections, chosen in such a way that they may interlock, and then applying a molding material such as clay or plaster of Paris to create the mold.⁴⁰ The piece mold is then used to obtain an *inter model*,⁴¹ i.e., a positive replica of the model normally made in wax that can then be invested and cast. The use of piece molds allows the bronze caster to make multiple casts from the same model. These casts will be identical in both form and size, except for differences in finishing work subsequent to the casting.

³⁹ The use of this technique should be further researched through the technical analysis of bronze fittings, an area of study that has thus far been neglected.

⁴⁰ The use of plaster is known from finds of plaster molds used for making wax inter models throughout the Hellenistic world. An assortment of late Hellenistic and early Roman plaster molds for the production of multiple casts is described in Edgar (1903, iii-xiii). For an example of a late Hellenistic life-size plaster mold of a male back from Nea Paphos, Cyprus, see Nicolaou (1972, 315-6, pl. 66, fig. 38).

⁴¹ This useful term was first introduced by Stone (1982, 95, n. 25) to describe the positive made from a model mold in the indirect process.

In order to produce a hollow cast by the indirect method, there was one main difficulty to overcome: that of making a core uniformly smaller than the inter model in order to control the wall thickness of the cast. The various methods by which the bronze caster could control the wall thickness of the inter model depended on whether he wished to make the inter model first and the core afterwards (fig. 5-*A₁*), or vice versa (fig. 5-*B₁*).

In the *inter model-first* option (*A₁*), a positive was constructed by lining the mold with wax (*c*) applied by swilling (the word slushing is sometimes used), brushing, or by using preformed slabs. Swilling involved partially filling the mold with molten wax and swilling it about until a layer of wax had solidified on the interior, the surplus being drained off (this method is also referred to as slush casting).⁴² If the mold was too bulky, it could be lined by brushing molten wax to preserve fine modeling detail or by using warm wax slabs pushed into place by hand, and later followed by joining their edges with a hot iron or by pouring molten wax between them. Alternatively, the mold could be lined with clay applied as a paste or in preformed slabs in a similar manner to the wax (*d*).⁴³ Having lined the mold by either method, the core could be created by hand filling the cavity with refractory clay or by pouring a refractory liquid clay into the lined cavity. Once cored, the mold was removed and the inter model invested (*i*). When clay was used as the lining material, it had to be replaced with a wax inter model and only then could investment proceed (*j*).

In the *core-first* option (*B₁*), the bronze caster could cast the core in the unlined mold and then reduce it to the right size by paring it (*e*) or the core could be modeled free-hand in clay over an armature of the required shape (*f*).⁴⁴ Having produced the core by either method, the bronze caster then assembled the piece mold around it and filled the space between the two with wax to create an inter model that in turn could be

⁴² A detailed account of swill or slush molding is given by Birniguccio (1943, 231).

⁴³ Cellini (1967, 116), describes the process of lining the mold with wax, clay or paste in order to control the wall thickness of the final bronze cast.

⁴⁴ Haynes 1992, 29.

invested (*k*). The investment of the inter model in the indirect-casting process thus followed the same steps used in the direct-casting process.⁴⁵

One of the primary reasons for using a wax inter model was to avoid laborious finishing of the object in its metallic form. An alternative to the use of a wax inter model is offered through the use of a primary piece mold made of refractory clay instead of plaster (fig. 5, options *g*, *h*, and *l*, all marked by dashed line).

Theoretically, if the primary piece mold is made of refractory clay, it is possible to cast the bronze directly into it and in some instances to avoid the use of a wax inter model altogether (options *g*, and *l*), although this was rarely done.⁴⁶ Under the pressure of the molten metal the seams in the piece mold were likely to leak. When the metal hardened and the mold was broken away, every leak became a projecting fin of metal that needed to be laboriously filed down.⁴⁷ The use of a wax inter model facilitates finishing by allowing retouching of the wax inter model instead of the metal object.

The reason for replacing the primary plaster piece mold with a secondary clay investment mold (options *i*, *j*, and *k*) lies primarily in the thermal expansion of plaster, which renders it unsuitable as a refractory material.⁴⁸

The development of piece molding techniques was a significant innovation in casting technology. It allowed the mass production of small and relatively simple bronzes, as well as very large bronzes that for the first time could be cast in sections by using separate molds taken off the same model, and then joined together into large and

⁴⁵ For a detailed historic account of the piece-molding process, see Cellini (1967, 115-6). A detailed practical account of modern statue casting is given by Mills (1969).

⁴⁶ The use of refractory clay molds over a pared core as presented by option *B₁-e-l* in fig. 5, is suggested by Gabrielle (1932, 338-40) in his reconstruction of the casting of the Colossus of Rhodes and by Haynes' theory (1992, 125-6) of the construction of the Athena Promachus. For a step by step description of this casting process see page 75.

⁴⁷ See Haynes (1992, 43-6, pl. 5) for a discussion of archaeological evidence from a Samian griffin-protome that was cast in a refractory piece mold and the implications of this production method.

⁴⁸ Edgar (1903, viii) indicates that the plaster molds at the Cairo Museum could only sustain low temperatures due to their high brick-dust content. Stone (1982, 108) points out that a plaster mold will crack if heated red-hot due to thermal expansion, and that only with the addition of silica to plaster, first recorded by Leonardo de Vinci at the end of the 15th century was this problem overcome.

complex forms.⁴⁹ The use of piece-molding techniques is dated to the seventh century B.C. on the basis of three hollow cast griffin-protomes wasters from the Samian Heraeum.⁵⁰ The surface of the protomes is covered by linear casting webs formed by the metal seeping into the joints between the various parts of the mold. Further evidence for the use of piece-molding techniques is provided by a matching set of eight finished griffin-protomes. All eight agree closely in their main dimensions, suggesting that they were cast from an identical wax inter model that could only be obtained by means of a piece mold.⁵¹

Casting Installations

Casting-pits

Casting-pits were temporary installations often built for specific commissions, their design made to accommodate a specific mold and to facilitate the pouring of the heavy molten bronze. The typical Greek casting-pit was a trench cut into the bedrock or sunk into the earth. The pit was normally pear shaped in plan, consisting of a main chamber of roughly circular shape, often with one narrow, stepped, service-passage leading down into it (fig. 6). After the casting was completed, most casting-pits were abandoned and they were often back-filled with casting debris and earth. Casting-pits have thus been preserved at many archaeological sites throughout the ancient Greek world.⁵²

The size of a casting-pit is significantly greater than that of the object to be cast, so that it can accommodate the positioning and handling of the investment mold and its baking (fig. 7). If a mold will be too heavy to be moved, when completed, its construction would likely take place in the casting-pit. After the mold was positioned in

⁴⁹ Treister (1996, 330-1) states that the growing use of indirect-casting techniques during the Hellenistic period was associated with the growing demand for metal articles and the growing popularity of reproductions of Greek originals.

⁵⁰ Haynes 1992, 43-6, pl. 5.

⁵¹ Haynes 1981, 136-8.

⁵² See Treister (1996, 190-4, 294-7) for a summary of the various casting-pits that have been identified throughout the ancient Greek world.

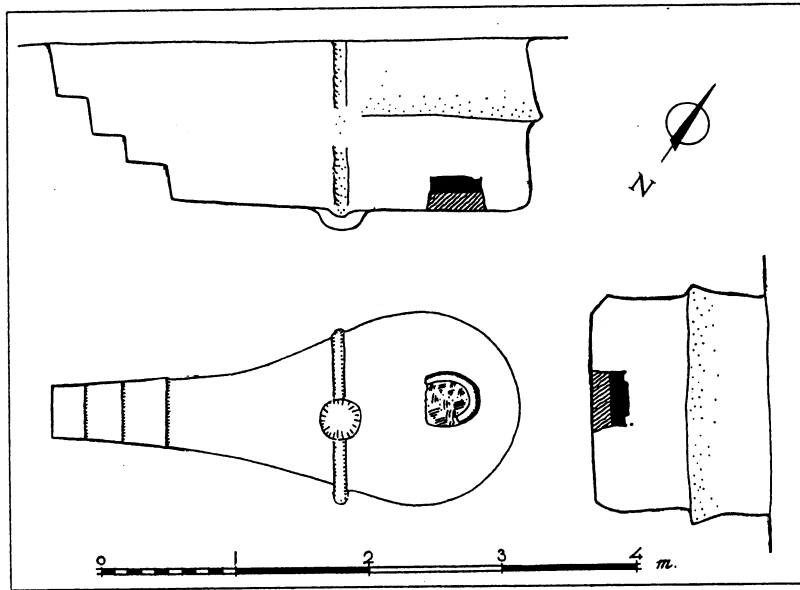

Fig. 6. Casting pit-on the west slope of the Areopagus. The drawing shows, from left to right, service steps, a groove for a retaining wall, a receptacle for the molten wax, and a mold base. (After Thompson 1948, fig. 7)

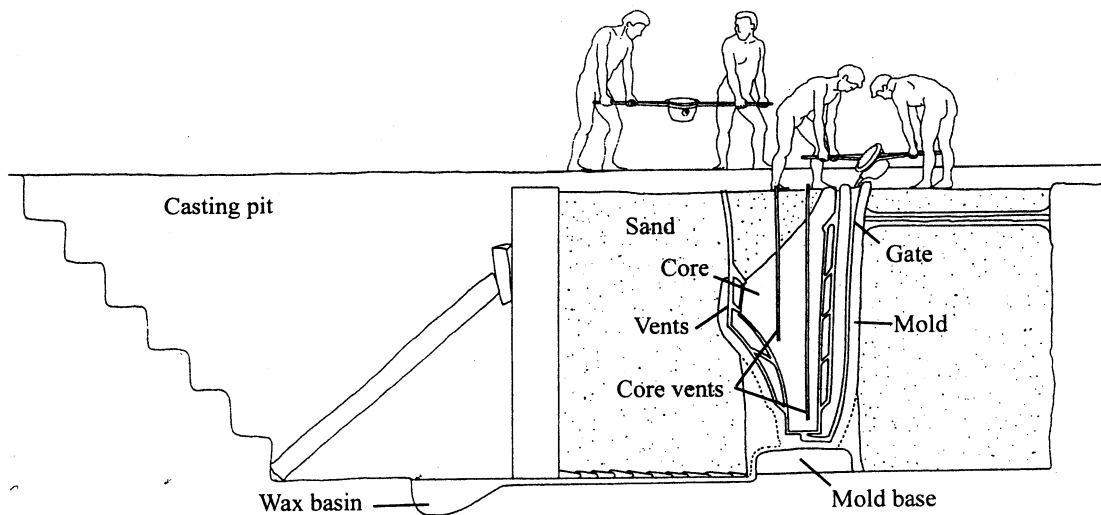

Fig. 7. A reconstruction of a ram casting-pit in operation. (Drawing by the author)

the casting-pit, a temporary retaining wall was constructed to facilitate the firing process and to reduce the amount of sand needed to pack the pit in the subsequent casting.⁵³ The gate system leading into the buried mold was often extended with clay pipes to carry the metal from the furnace or crucible into the mold,⁵⁴ and temporary clay stoppers were often inserted into their openings to prevent filling material from falling into the gate system.⁵⁵ The dimensions of casting-pits provide a rough indication of the size of the objects cast in them, as well as suggesting the positioning and orientation of the investment molds during the casting. The majority of Greek casting-pits are of relatively modest size. This is not surprising considering the Greek practice of casting statues in sections. Few large casting-pits have been excavated. These include a casting-pit, possibly of Roman date, measuring 2.31 m in depth with a floor of 3.09-3.26 x 4.14-4.34 m at the Gymnasium Foundry in Corinth⁵⁶ and two colossal casting-pits in Rhodes, dating to the early third century B.C. The larger of the two measures 11 m in length, 3.25 m in width, and is 3 m deep. At present, it represents the largest casting-pit known from the ancient world. Its colossal size attests to the magnitude of the objects cast in it and to the overall technical sophistication of Hellenistic bronze foundry practices.⁵⁷

Mold Bases and the Orientation of the Mold during Casting

The investment mold was positioned on a mold base, an elevated platform of clay, brick, tiles, or stones built in the center of the casting-pit (figs. 6, 7). The role of the base was to support the mold during firing and to facilitate the draining of the wax through an opening at the bottom of the mold.⁵⁸ It appears from the dimensions of excavated mold bases, which are normally only big enough to support the mold's narrow dimension, that the investment molds were placed in the pit vertically rather than

⁵³ Kantzia and Zimmer, 1989, 516; Willer 1994, 962-3, fig. 10.

⁵⁴ Clay pipes used for channeling the melt into the mold were found in many foundry sites, for an example see Shear (1937, 342-3).

⁵⁵ Haynes 1992, 76.

⁵⁶ Mattusch 1991, 383-9, figs. 1-2.

⁵⁷ Kantzia and Zimmer, 1989, 500-22. figs. 2, 4, 6-7.

⁵⁸ Mattusch, 1988, 229; 1991, 383-5.

sideways. Such positioning is logical as it assists the draining of the molten wax during the firing of the mold and facilitates the flow of metal during the casting stage.

Post-Casting Work

After extraction by breaking the mold, the cast bronze object needed certain additional cold working before it was completed. The “fire skin” (copper oxide) covering the surface of freshly cast bronze was removed using abrasives such as pumice stones and rasps. The remains of these were found in the Gymnasium bronze foundry at Corinth.⁵⁹ The bronze caster would also have sawn, chiseled, or filed off the gate and vent systems, now of bronze, as well as any large excrescencies resulting from cracks in the mold. At this stage, the chaplets would also be removed, either by cutting bronze chaplets flush to the surface of the object, or by removing those of iron.

Joining

To overcome some of the complications associated with handling and casting large quantities of molten bronze, whenever possible, Greek bronze workers resorted to casting large bronzes in sections to be attached later using an array of joining techniques.

Ancient joins on Greek statuary fall into two categories: mechanical and metallurgical. Mechanical joins consist of interlocking parts and were achieved through the application of physical forces, such as hammering, bending, twisting, crimping pinning, and often with additional reinforcement using metal rivets, pegs or bolts. Interlocking could also be achieved by casting together the members of a join that were designed to become locked when the molten metal solidified.⁶⁰ An early example of interlocking-cast joins is found on early Greek tripods, in which the various structural elements were locked together by the casting of a sleeve or a foot of an alloy with a lower melting point that, once cooled, locked in place the various members of the join.⁶¹

⁵⁹ Mattusch 1991, 392.

⁶⁰ Lechtman 1970, 6-9.

⁶¹ Rolley 1983, 122-3.

In contrast, metallurgical joins are based on the inter-atomic interaction of the two joined elements to form a continuous metallic structure. The two primary types of ancient metallurgical joins on bronze are soldering (soft and hard), and fusion welding.⁶² Soldering techniques are based on the introduction of a solder, an alloy with a melting point lower than that of the metal to be joined, so that when it melts between the edges of the join, it wets them and adheres to them but does not fuse them as in welding.⁶³ Low melting point solders are referred to as soft solders and high melting point solders are referred to as hard solders. The strength of the join depends on the closeness of the melting point of the solder to that of the metal to be joined. To make a join strong enough to hold together the main sections of a bronze statue, it would be necessary to use a hard solder with a melting point only slightly lower than that of the bronze used for the statue itself.⁶⁴ However, heating such solder to a temperature within the narrow band between the two melting points would have been a difficult task for the ancient craftsman.⁶⁵ This in turn may explain why definite examples of hard soldering have not yet been recognized in Greek statuary. Nor was there any advantage to the use of soft solder, as it would have resulted in a join that was too weak for the attachment of anything except small details that were not subject to stress.⁶⁶

In fusion welding, a bond takes place between the welding material and the metal to be joined as their surfaces melt, fuse and solidify integrally. In order to weld two bronze pieces together, it is necessary to heat the surfaces to be joined until they melt and actually flow together. As in hard soldering, introducing enough heat to the area is the primary problem. One solution was to pour a continuous stream of superheated metal onto the area of the join in a method known as flow welding.⁶⁷ The stream of metal, in quantity greater than what was needed to fill the gap had to not only be

⁶² See Maryon (1949, 102-15) for an overview and definitions of these techniques.

⁶³ Maryon 1949, 107; Lechtman 1970, 6-7.

⁶⁴ The term brazing is sometimes used to describe the process of hard soldering. According to Maryon (1949, 108) a "brazed joint" is one in which copper or an alloy of copper is employed as a solder.

⁶⁵ Lechtman 1970, 10-3.

⁶⁶ Haynes 1992, 98; Lechtman 1970, 9-10.

introduced to, but also conducted away from, the join until the area had reached the temperature of fusion, with the molten bronze acting both as a heat source and as filler.⁶⁸ The flow welding process was often contained in a purpose-built clay mold over the area to be welded.⁶⁹ Evidence for the use of flow welding is often found in the form of excess filler metal remaining on the interior surface of the join.⁷⁰ In some cases, the surface area along the join was increased by cutting half ovals in the outer surface of the bronze on either side of the join, so that, when brought together, they formed oval basins. These were then covered with a localized mold that allowed the welding metal to fill the basin as well as the join, thereby greatly increasing its hold by spreading the metallurgical bond beyond the narrow area presented by the adjoined edges (fig. 8).⁷¹

Variations on the use of fusion welding-techniques may include a combination of metallurgical and mechanical techniques in a single join. In such cases, two sections specifically designed with projecting edges are held together by a large mass of bronze that was poured over the whole area, effectively clamping them together but also with some level of fusion involved.⁷²

Repairs

Casting flaws were normally repaired using patching techniques. Like joining techniques, these include both mechanical and metallurgical methods. Small blow-holes, cracks, and holes left by chaplets were commonly patched mechanically. Having cut out a rectangular recess with a slightly undercut profile, the bronze caster prepared a bronze patch slightly smaller than the cut and inserted it into the recessed area. The patch was then hammered flush, thus expanding and locking in place (fig. 9). In some

⁶⁸ Maryon 1949, 104-6; Lechtman 1970, 14.

⁶⁹ Maryon 1949, 105; Lechtman 1970, 31-2.

⁷⁰ Steinberg 1973, 104.

⁷¹ Haynes 1992, 95; Steinberg 1973, 136; Formigli 1984, 124. See Sobotka-Braun and Willer (1994, 1019, figs. 5-7) for an experimental reconstruction of the flow welding technique.

⁷² Steinberg (1973, 115-6, fig. 33) describes a method by which the various ends of drapery sections were secured by a combination of mechanical interlocking and partial fusing. The ends of these sections were inserted through holes in the torso and molten bronze was then poured around the projecting ends until a lump was built up. This kept the projections from slipping out, both mechanically and by partial fusing.

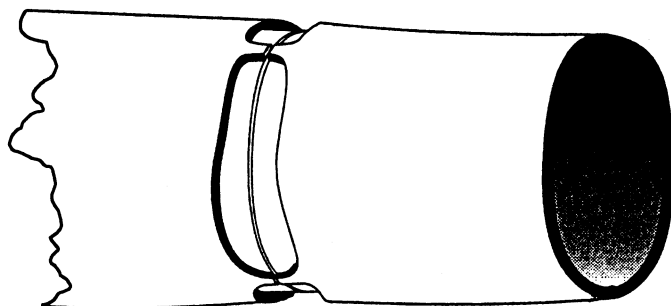

Fig. 8. Enlarged surface area along a fusion weld joint. (After Sobottka-Braun and Willer 1994, fig. 6)



Fig. 9. The application of a bronze patch to an undercut bed over a faulty surface. (Drawing by the author)

instances, a lead foil was inserted underneath the patch to facilitate interlocking with lighter hammering when the thinness of the object's walls did not allow heavy work.⁷³ Mechanical patching was widely used on cast bronzes, probably due to the ease of the technique and its suitability for small casting faults. It is therefore common to find large numbers of patches in a single statue.⁷⁴ The larger number of rectangular bronze patches found around the Gymnasium foundry in Corinth suggests that the repair work was probably done near the casting-pit, soon after casting.⁷⁵

The nature of the mechanical patching technique limits its use to relatively simple, flat surfaces. Areas with larger casting faults require a more involved technique that can provide greater physical strength and a certain amount of plasticity in order to reconstruct castings in the round. In such instances, an alternative repair method was employed, introducing replacement elements by metallurgical means. Using clay, the bronze caster constructed a temporary mold over the damaged area into which he then poured molten bronze. A repair of this type was observed above the right breast of the "Lady from the Sea," its presence being revealed by two horizontal bands of darker metal on the outside of the bronze and by an area of slightly raised and lumpy metal on the inside.⁷⁶ In this area, the bronze caster patched a large hole by enclosing it from the front in a local mold and pouring in molten metal from behind. This technique of repairing or adding elements to an existing bronze object is often referred to as 'casting-on'.⁷⁷ In cases where more intricate repairs were required, the missing element may have been shaped in situ in wax and then invested, thus creating a perfect match between the surrounding surface and the repair. Evidence for this technique is indicated at by cast-on repairs found on the Athlit ram, the examination of which indicates a close dimensional relationship to their surroundings. The latter could best be achieved by

⁷³ Willer 1994, 965-7, figs. 11, 13.

⁷⁴ For an example, many of the bronze fragments from the Porticello wreck had their outer surfaces heavily patched, (Ridgway 1987, 85).

⁷⁵ Mattusch 1991, 392.

⁷⁶ Steinberg 1973, 115, figs. 32-33.

⁷⁷ Maryon 1949, 105-6.

modeling in wax and casting in situ each of the repairs. These repairs on the ram will be further discussed in chapter 5.⁷⁸

Final Finishing

After the removal of all the casting remains and after the surface had been patched and repaired, the bronze caster proceeded to the final finish of the work. Some of the tools used at this stage are depicted on the Berlin foundry cup.⁷⁹ These include round-headed hammers used for flattening minor protrusions and consolidating areas of porous metal, as well as scrapers or rasps in the shape of strigils⁸⁰ used for smoothing the surface or for removing casting remains. Fine detailed work such as hair grooves and drapery folds may have been further refined using chisels, punches and tracers. For final polishing, pumice stone, cuttlefish bone, and other abrasives may have been used.⁸¹

⁷⁸ See Lechtman and Steinberg (1970, 14-22) for a technical analysis of a cast-on repair on an eighth-century B.C. Greek bird.

⁷⁹ Steinberg 1973, 104, figs. 1-2. A metallographic cross section taken by Lechtman and Steinberg (1970, 30) through a fusion weld from a second-century A.D. Roman sculpture of a draped man contained slip bands indicating that the line was cold worked after cooling to make it as unobtrusive as possible.

⁸⁰ Willer 1994, 967.

⁸¹ Haynes 1992, 102.

CHAPTER III

CLASSICAL AND HELLENISTIC COPPER ALLOYS

The analysis of bronze alloys from the ancient world demonstrates that Greek bronze workers learned at an early date how to control and adjust alloy compositions to fulfill specific physical requirements.⁸² A study of Late Bronze Age swords from Greek sites have shown them to be made mostly of tin bronze, with a tin content varying from 6.8% to 12.4% and averaging 9.3%, with only trace levels of lead.⁸³ The absence of lead may have improved the cold working properties of the alloy (see below). In contrast, statuettes of similar age are of highly variable composition, with widely ranging levels of tin and lead.⁸⁴ The lack of care suggested by the range of compositions of the Late Bronze Age statuettes probably reflects their decorative use and the relative unimportance of the physical properties of the alloy. Analysis of Classical and Hellenistic bronzes shows a continuation of the selective use of copper alloys and a progressive increase in alloy specialization. While copper-tin alloys continued to be the primary alloy in use, more sophisticated alloys such as Corinthian bronze, brass, and gold-mercury amalgams made their first appearance towards the end of the first millennium B.C.

The following chapter introduces the main copper alloy groups used by Classical and Hellenistic bronze workers, alongside the available archaeological, literary and analytical evidence.

⁸² Craddock 1976; 1977; 1978.

⁸³ Craddock 1976, 101-2, fig. 5.

⁸⁴ Craddock 1976, 101, figs. 3-4.

Copper-Tin Bronze

The addition of tin to copper lowers its melting point from 1083 °C to 1050 °C with 7% tin and to 1020 °C with 10% tin. This helps to maintain the alloy in a liquid state for a longer period during the casting process (fig. 10). Furthermore, molten copper absorbs gases that can prevent it from flowing freely into the mold and cause blow holes that weaken and disfigure the cast. The addition of tin to the melt greatly reduces such problems. Finally, the mechanical properties of cast bronze especially after subjected to cold working, are superior to those of pure copper. The presence of tin improves the wrought condition of the alloy, owing to a more rapid work hardening (fig. 11).⁸⁵ The addition of up to about 10% tin results in an increased tensile strength and hardness. Hardness continues to increase beyond this point, but is accompanied by increasing brittleness, rendering bronze with more than about 15% tin unsuitable for most tasks.

Leaded Bronze

From the middle of the second millenium B.C., leaded bronze was used with increasing frequency for cast metal work.⁸⁶ The addition of lead to a copper tin alloy reduces its melting point and significantly increases the fluidity of the molten metal. In addition, leaded bronzes are relatively easy to drill, file and grind.⁸⁷ However, increasing the amount of lead also has some major disadvantages. Lead is insoluble in copper and therefore becomes heavily segregated during solidification. Small amounts of lead remain dispersed throughout the copper, but at concentrations of more than a few percent, there is an increasing tendency for the lead to link up, forming macroscopic pools or globules that not only detract from the appearance of the bronze, but also reduce its structural cohesion. Consequently, while lead is beneficial to the casting process, it is detrimental to alloys that are to be worked by hammering.⁸⁸

⁸⁵ Tylecote 1979, 8, fig. 2.

⁸⁶ Craddock 1976, 94-5.

⁸⁷ Steinberg 1973, 135; Haynes 1992, 83; Ponting 1999, 1316.

⁸⁸ Ponting 1999, 1316.

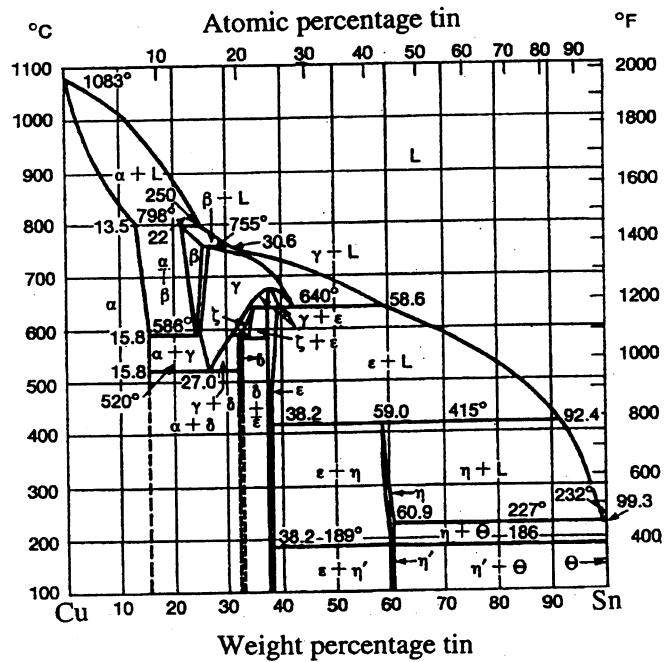

Fig. 10. Phase diagram of a copper-tin alloy system. (After Smith 1965, fig. 10)

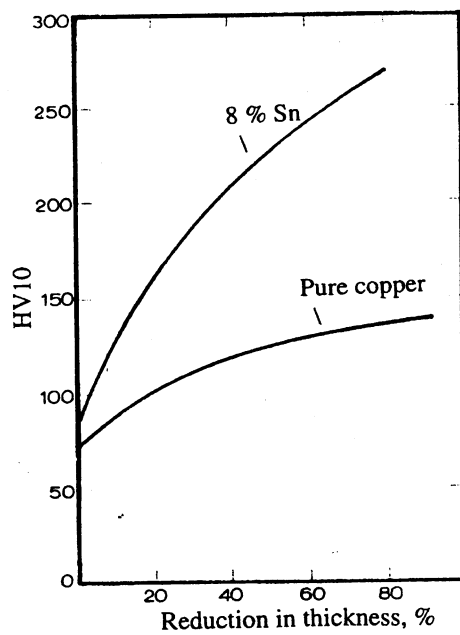

Fig. 11. The effect of the addition of tin to copper on the hardness after cold working. (After Tylecote 1979, fig. 2)

For this reason, hammered metalwork never contains more than trace quantities of lead. Finally, the tendency of lead to concentrate at the surface upon cooling presents a problem in certain classes of objects. These include metal objects intended for mercury gilding, in which the presence of lead interferes with the gilding process by solubelizing in the mercury-gold amalgam.⁸⁹ This also occurs in tin-bronze mirrors, where the lead interferes with surface polishing.⁹⁰

Brass

A copper alloy in which zinc is an intentional ingredient is called brass (usually containing about 5% zinc or more).⁹¹ Zinc has a similar effect to lead in reducing the melting point of copper alloys. Furthermore, zinc has a greater affinity for oxygen than tin and its addition to the melt facilitates a more efficient removal of dissolved oxygen, which may otherwise spoil the surface and weaken the cast.⁹² The impact of zinc on the mechanical properties of bronze is minimal, as these are almost entirely dependent on the tin content.⁹³

Alloys and Alloying Practices: Literary Evidence

Tin bronze

Book 34 of Pliny's *Natural History*, which is devoted to copper and bronze, states that the most popular alloys in the earliest period of Greek bronze casting were invented on Delos and Aegina.⁹⁴ Workshops renowned for their skill in alloying and casting flourished on both islands.

⁸⁹ The earliest pieces of mercury gilt metalwork are fourth-century B.C. rings from the British Museum collection analyzed by Craddock (1977, 109-10). Their alloy consists of copper with a low tin content and only traces of lead. The reason for this is that lead, tin, and zinc form an amalgam with mercury relatively easily, spoiling the gilded surface. Lead is especially likely to have this effect as it exists as separate globules in the bronze that tend to concentrate on the surface of the object.

⁹⁰ Craddock 1985, 61-2.

⁹¹ Scott and Podany 1990, 32.

⁹² Mills and Gillespie 1969, 10.

⁹³ Haynes 1992, 83-4.

⁹⁴ Plin. *NH.* 34.4-5.

The accounts of the casting of the Athena Promachus contain fragmentary listings of the quantities of metal bought during six of the nine years taken to complete the statue (probably between 464-455 B.C.).⁹⁵ The erratic quantities reported in the listing cannot be used to calculate the proportions in which Phidias alloyed the two metals, but the separate entries for copper and tin clearly indicate that he did not purchase his bronze ready-mixed. Separate entries for copper and tin are also recorded in the fragmentary Athenian inscription for the casting of Hephaestus, Athena and the *anthemon* (probably some type of floral ornament) for the Hephaesteum at Athens (421-415 B.C.).⁹⁶ Lines 142-3 records the purchase of 1 1/2 talents and 23 1/2 minas of tin along with a quantity of copper, presumably for the anthemon. The weight of the copper, though partially obliterated, was either 13, 15 or 19 talents and 10 minas. Thus the bronze must have contained between 8.98% and 12.56% tin. Also of importance is the fact that the tin was calculated to the nearest half of a mina (little less than 0.5%) and the copper to the nearest 10 minas (between 0.78-1.4%), an indication of the fairly high degree of accuracy to which the bronze caster aimed in mixing his alloy.⁹⁷

Corinthian bronze

According to Pliny, the fame of Delian and Aeginetan bronze was eventually eclipsed by that of Corinthian bronze, which contained gold and silver and varied in color according to the proportions of these two ingredients.⁹⁸ Pliny lists three separate Corinthian alloys that were used specifically for utensils or vessels and one alloy that was used for portrait statues. Of the first three alloys one is white, with a brilliance close to silver, which Pliny believed contained a significant quantity of silver; the second is yellow like gold; and the third has no specified appearance, and was composed, according to Pliny, of all the previous metals blended in equal amounts. The fourth

⁹⁵ *IG I³* 435.10-13 (restored), 42-45 (restored), 69-72 (restored), and 101-05.

⁹⁶ *IG I³* 472.

⁹⁷ Harrison 1977, 139-44; Haynes 1992, 85.

⁹⁸ Plin. *NH* 34.3.

alloy, for which Pliny provides no formula, is a bronze with a 'liverish' color highly valued for portrait statues.⁹⁹

Small quantities of gold and silver incorporated in copper are known to have a dramatic influence on the resulting alloys if they are subsequently treated in a suitable manner. With regard to the fourth alloy described by Pliny, Craddock suggests that it may have resembled the *shakudo* alloys of Japan. These are bronzes to which gold and silver were added in small quantities to give them an attractive purple-black patina when treated with chemical solutions.¹⁰⁰ Jacobsen and Weitzman compare the Corinthian alloys with the *tumbaga* copper alloys of pre-Columbian Peru, which also contained varying amounts of gold and silver. These alloys were made to look like gold or silver through a process described as depletion gilding, involving the oxidation and removal of copper from the surface, thereby leading to its enrichment with the remaining silver or gold.¹⁰¹

Brass

References to brass or *oreichalkos* ("mountain copper") gradually become common in Greek literature from the seventh century B.C. onward.¹⁰² The Greeks first used the word *oreichalkos* in its poetic or literary sense; only later was it used in technical contexts. The earliest reference occurs in Hesiod's poem *Shield of Heracles* probably written during the seventh century B.C. It has been translated as follows: "so he spoke and placed about his legs his greaves of shining *oreichalkos*, the glorious gift of Hephaistos."¹⁰³ The authors of the early references to *oreichalkos* describe it as a rare metal of brilliant color and great value. By the fourth century B.C., the term started to be used by Greek technical writers to designate copper-zinc alloys. Perhaps the most important reference among these is contained in the *Philippica* by the geographer

⁹⁹ Plin. *NH* 34.3.

¹⁰⁰ Craddock 1982, 69.

¹⁰¹ Jacobsen and Weitzman 1992, 242-4.

¹⁰² Young (1981, 248, n. 128) reports a unique find of early brass from Gordion, consisting of three fibulae dated to the eighth century B.C. The chemical analysis of these fibulae by Steinberg (1981, 288-9) indicates zinc content in excess of 10%.

¹⁰³ Hes. *Shield of Heracles* 121-2.

Theopompus, written in the fourth century B.C. The original work is lost but substantial quotations were made from it by Strabo.¹⁰⁴ The text of the relevant quotation from Strabo reads as follow: "There is a stone near Andeira (a town in northwest Asia Minor) which yields iron when burnt. After being treated in a furnace with certain earth it yields droplets of false silver. This, added to copper, forms the so-called mixture, which some call oreichalkos." Craddock suggests that the "droplets of false silver" added to the copper are metallic zinc and that the process described may be an early account of zinc distillation.¹⁰⁵ The absence of archaeological evidence for zinc distillation at this date requires that this literary evidence be interpreted cautiously. Only one example of metallic zinc has been found in a contemporary archaeological context¹⁰⁶ and the use of brass is not reflected in the analytical data, indicating the absence of zinc in the majority of Greek bronzes (see below).¹⁰⁷ It is therefore suggested that this new alloy was used on a limited scale until the first century B.C., when the cementation process was introduced, allowing large quantities of brass to be produced.¹⁰⁸

Analytical Evidence

With few exceptions, all the pre-Hellenistic large-scale bronze statuary analyzed to date consist of simple binary alloys of copper and tin. Table 1 sets out the percentages of copper, tin, and lead of those Greek statuary for which analyses are available. Tin content varies from 3.4% to 13.5%, although in unleaded bronzes it is seldom less than 7%, and normally falls within the range of 9-11%. Its variation is too irregular to suggest any chronological pattern. Of the pre-Hellenistic statuary bronzes, only two, both from western Greece, contain lead in sufficient quantity to suggest that it was an intentional ingredient of the alloy.

¹⁰⁴ Strab. *Geography* 8.56; also described by Craddock 1978, 6.

¹⁰⁵ See Craddock (1978, 6-7) for a technical interpretation of the passage as a description of zinc production.

¹⁰⁶ See Fransworth, Smith and Rodda (1949) for a description of a small fragment of metallic zinc dating to the fourth or third century B.C. found at the Athenian Agora.

¹⁰⁷ Craddock 1978, 1.

¹⁰⁸ Craddock 1985, 63.

Since leaded bronze was widely used for statuettes in the Archaic and Classical periods (see below), Haynes speculates that its absence in large-scale statues may have derived from aesthetic considerations, such as the deadening effect of lead on the bright golden tone of a simple copper-tin alloy.¹⁰⁹

Large-scale statues containing an increased amount of lead begin to appear in mainland Greece and Asia Minor from the end of the fourth century. Lead levels gradually increase through the Hellenistic period and by the Roman period they are often as high as 30%.¹¹⁰ Nevertheless, unleaded bronze continues to occur sporadically in the later Hellenistic period and it is only during the Roman Empire that heavily-leaded bronze become the rule. Interestingly, significant amounts of lead are found in many of the pre-Hellenistic bronze statuettes analyzed by Craddock. In this group, lead levels range between 1.0-21.6%, with a scattered distribution that suggests no specific lead content was preferred. This trend continues into the Hellenistic period, when even higher levels of lead (up to 30.5%) are seen.¹¹¹ The general increase in the lead content of copper-tin alloys towards the Roman period may be related to economic factors. Because lead is cheaper than tin, its addition to alloys would have reduced production costs. Also related to economic factors may be the gradual reduction in the wall thickness of statues towards the beginning of the Roman period. The mean thickness of Greek statues decreases in the course of the fifth and fourth centuries, falling from 1.0 cm at the beginning of this period to 0.5 cm at its close. This tendency continues in Hellenistic bronzes (table 2). Casting thinner walls would have reduced the amount of metal used, but would have also required a more fluid alloy that could be achieved by using greater amounts of lead.¹¹² The growing use of lead may also result from its production as a by-product of silver processing, suggesting that the increase in lead

¹⁰⁹ Haynes 1992, 88.

¹¹⁰ Scott and Podany 1990, 33-4.

¹¹¹ Craddock 1977, figs. 2, 4, 7.

¹¹² Haynes 1992, 67-9, 88.

content in alloys from the Hellenistic period onwards may be related to the increase in silver production from argentiferous lead at centers such as Laurion.¹¹³

¹¹³ Craddock 1985, 62.

Table 1. Analysis of Greek statuary bronzes. (After Haynes 1991, table 2)

		Date	Copper %	Tin %	Lead %
1	Apollo from Piraeus	c. 525	87.0	10.0	-
2	Zeus from Ugento	c. 500	86.78	8.47	3.58
3	Youth from Selinute	c. 470	88.07	9.94	1.05
4	Piot Leg	c. 470	85.0	8.5	8.68
5	Chatsworth Head	c. 460	87.5	10.4	0.02
6	Riace Statue A body head	c. 460	88.8 87.35	10.75 12.41	- -
7	Riace Statue B body head	c. 460	90.8 85.94	9.26 13.5	- -
8	Porticello Head	c. 440	89.6	8.9	1.5
9	Porticello Athlete	c. 440	90.8	8.8	0.4
10	Head of Nike from Agora	c. 420	91.0	8.4	0.27
11	Athena from Piraeus	c. 350	87.0	11.0	1.0
12	Artemis from Piraeus	c. 320	86.0	12.0	1.0
13	Berber's Head from Cyrene	c. 330	91.0	7.95	0.16
14	Youth from Marathon	c. 320	88.5	2.9	-
15	Getty Youth	c. 320	89.0	10.7	0.05
16	Aproxymenus from Ephesus	c. 300	89.0	6.09	4.87
17	"Demetrius Poliorecetes"	c. 300	66	3.26	26.4
18	Girl from Cyzicuz	c. 275	73-75	7-9	16-18
19	Hellenistic Ruller	c. 150	89	8	3
20	Head of Sophocles	c. 150	91.5	6.75	0.27
21	Head of Aphrodite	c. 100	67.5	5.6	26.0

Table 2. Thickness of Greek statuary bronzes. (After Haynes 1991, table 1)

		Date	Thickness (mm)
1	Apollo from Piraeus	c. 525	6-8
2	Head of Zeus from Olympia	c. 500	7-12
3	Lion from Cyprus in Istanbul	c. 500	3-7
4	Drapery fragment from Olympia	c. 500	12-15
5	Drapery fragments from the Acropolis	c. 490	5-13
6	Horn of Eretrian Bull	c. 490	10
7	Warrior's head from the Acropolis (Athens, N.M. 6446)	c. 480	7-10
8	Fragment of draped figure from Olympia	c. 480	12-15
9	Poseidon from Kreusis (Athens, N.M. 11761)	c. 480	4-7
10	Delphic Charioteer	c. 470	8-25
11	Chatsworth Head	c. 460	10
12	Riace Statue A Statue B	c. 460	8.5 7.5
13	Bearded head from Porticello	c. 450	4.5-7
14	Boar from Edirne	c. 450	6-15
15	Athena from Piraeus	c. 350	4-6
16	Head of Berber (Brit. Mus.268)	c. 330	5-8
17	Marathon Youth	c. 330	3-4
18	Boxer from Olympia	c. 320	10
19	Apoxyomenus from Ephesus	c. 300	3-8
20	"Lady from the Sea"	c. 300	2-3
21	Philosopher's head from Antikythera	c. 250	3-4
22	Ackland Head	c. 200	2-3
23	Sleeping Eros	c. 150	5
24	Jockey from Cape Artemisium (Athens)	c. 100	3
25	Horse from Cape Artemisium (Athens)	c. 100	2
26	Head of Aphrodite from Satala	c. 100	2-3
27	Child's head from Olympia	c. 100	5
28	Portrait head from Delos (Athens)	c. 90	4-7

CHAPTER IV

LARGE-SCALE BRONZE CASTING IN THE ANCIENT WORLD

The following chapter surveys the archaeological, literary, and iconographic evidence for large-scale bronze casting in the ancient world. While it focuses on Classical and Hellenistic bronzes, evidence from neighboring cultures of contemporary and earlier age is also incorporated in order to provide a wider technical and chronological perspective.

The complexity of casting large portions of bronze is a direct outcome of a long list of variables that increases in direct proportion to the scale of the cast. This implies that the larger the cast, the greater the chances of failure.

Since the casting process involves a mold and often a core, as well as molten metal, the problems that develop may derive from the refractory material, from the bronze itself, or from the interaction between the two. The mold must be thoroughly dried before the metal is introduced. Unless it is fired slowly and uniformly, it is likely to crack. If it is not dry enough it will generate water vapor when the hot metal is poured in, and if it is not sufficiently porous it may fail to expel gases from the melt, leading to an unsound cast full of gas pockets and blow-holes. The bronze itself must be free of dross and other impurities so that it will solidify evenly and produce a reasonably uniform surface. It must also be as free as possible of the gases that are easily absorbed during the melting process.

Another important requirement is a good mold design. The proper placement of the gates through which the metal is poured, the arrangement of vents to allow gases to escape, and the positioning of the core so that it does not shift, are all crucial to a successful result. In the case of large-scale castings, these difficulties are magnified by the size of the mold, the considerable quantities of molten bronze needed, the necessity of an uninterrupted pour, and by the uneven shrinkage of such a large mass.

Given the range of complications described above, it is not surprising that many of the monumental bronzes of antiquity were cast in small sections and subsequently

assembled to form a finished object. Few large bronzes that were cast as a single unit have survived from the ancient world to shed light on the technical aspects involved in their production. The Athlit ram and a few other finds represent our only archaeological evidence for such objects. This scant record can be somewhat supplemented through the use of literary and iconographic evidence to provide increased perspective.

Archaeological Evidence

Within the ancient Greek world only the Athlit ram, and possibly the Serpent Tripod column from Delphi (479 B.C.), later erected at the at the hippodrom of Constantinople by Constantine the Great, qualify as large-scale single-piece cast bronzes. The height of the 29 preserved coils of the Serpent Tripod column is 5.35 m. The diameter of the column's uppermost coil is 63 cm, while the diameter of the column's lower section at the stone base is 150 cm. Six more coils are believed to have completed the column at the bottom, with an additional height of 38 cm.¹¹⁴ The wall thickness of one of the bronze snake heads at the İstanbul Archaeological Museum ranges between 1.0-1.5 cm and its walls are said to have a smooth interior surface.¹¹⁵ Considering the monumental size of the Serpent Tripod column, Mattusch thought it was more likely to have been cast in sections. However, no joins are visible on the exterior of the column, and it is possible that it was cast in a single piece.¹¹⁶ Until a technical study of this important object is conducted, no definite conclusion can be drawn regarding the techniques used in its construction.

Other known large Classical and Hellenistic cast bronzes, all of which fall under the category of statuary, were assembled of separately cast sections normally comprising the head, torso, arms, and legs.¹¹⁷ In some instances, however, an assembled cast bronze figure is of such magnitude that some of its sections may provide parallels for the Athlit

¹¹⁴ Ridgway 1977, n. 1, ill. 1, figs. 1-3.

¹¹⁵ Mattusch 1988, 97, n. 35, figs. 5-6.

¹¹⁶ Mattusch 1988, 97, n. 33.

¹¹⁷ Haynes 1992, 34-5.

ram. For example, the larger than life-size Riace bronzes (460 B.C.)¹¹⁸ found off the coast of Calabria weighed 500 kg at the time of their recovery.¹¹⁹ The statues each measure 1.9.7-1.98 m in height and were each cast in one large section consisting of the torso and legs, to which the hands and head were later attached.¹²⁰ The weight of this single cast unit may be roughly calculated, by subtracting the weight of the statue's core (for statue A more than 72 kg, for statue B more than 56 kg),¹²¹ heads (one head has been estimated at 20 kg),¹²² and arms (one arm has been estimated at 20 kg), giving a weight of 376 kg.¹²³ This figure, along with the thickness of the walls of the statues of 0.75–0.85 cm (see table 2), compares well with the dimensions of the ram. Another such parallel of an earlier date is the Piraeus Apollo (520 B.C.). This statue is 191 cm high and has a wall thickness of 0.6-0.8 cm (see table 2). It is reported to have had its torso and legs cast in one piece, in which case its weight should also fall within the same range as the Riace statues and the Athlit ram.¹²⁴

Although unknown in Greece before the sixth century B.C., life-size bronze casts of monumental scale are found in Mesopotamia as early as the third millennium B.C.¹²⁵ Of the few surviving examples, only two are more than fragments. These include the headless statue of the Elamite Queen Napir Asu from Susa (1275-1255 B.C.), a solid cast weighing nearly two tons,¹²⁶ and the lower section and base of an Akkadian figure of a seated standard-bearer from Bassetki in northern Iraq (2254-2218 B.C.), a hollow cast weighing 160 kg.¹²⁷

¹¹⁸ Mattusch 1988, figs. 8.3-4.

¹¹⁹ "Cover Story." 1982, 3.

¹²⁰ Formigli 1984, fig. 18.

¹²¹ Lombardi 1998, 1055.

¹²² This figure is based on the weight of the larger than life-sized Chatsworth head (460-450 B.C.), which weighs 19.5 kg (Haynes 1968, 104).

¹²³ Since the reported weight of the Riace statues may also include the weight of marine concretion, this value should be considered as an estimate.

¹²⁴ Mattusch 1988, 77, fig. 4.19.

¹²⁵ Moorey 1982, 34-5.

¹²⁶ Porada 1965, 61, fig. 37; Parrot 1961, 322, figs. 398-9.

¹²⁷ Moorey 1985, 30; Oats 1979, 36, fig. 17.

Literary and Iconographic Evidence

As discussed above, few examples of Near Eastern statuary of pre-Greek date have survived and none is later than the second millennium B.C. However, literary and iconographic evidence suggests that many large bronzes were produced in this area during the first half of the first millennium B.C. Such sources include the description of twelve figures of oxen, probably slightly smaller than life-sized, that supported the 'Brazen Sea' (a bronze basin) cast for Solomon (963-925 B.C.) by Hiram of Tyre.¹²⁸ It has been estimated that the 'Brazen Sea' alone weighed 200 tons. The oxen would have been cast separately.¹²⁹ Many bronze lion and bull colossi are accounted for in various Assyrian sources, where they are described as being incorporated in the architecture of Nineveh by Sargon II (721-705 B.C.)¹³⁰ and Sennacherib (705-681 B.C.),¹³¹ a precedent that inspired Nebucadnezer II (605-562 B.C.), Neriglissar (560-556 B.C.) and Nabonidus (555-539 B.C.) to erect similar monuments at Babylon.¹³² Furthermore, a list of booty captured by Sargon at Musasir in 714 B.C. gives a list of monumental Urartian cast bronze statuary,¹³³ of which no examples have survived.¹³⁴ In Egypt, large-scale bronze casting is depicted in the tomb of Rekhmire at Thebes (1425 B.C.). It records casting metal into the form of doors for the temple of Amun at Karnak. The depiction includes the use of a mold, bellows, a large crucible, and the pouring of metal through a series of seventeen funnels, indicating mastery of bronze casting technology. Of the mold itself, only a rectangular outline is shown; however, it has been suggested that it consists of baked terracotta.¹³⁵

¹²⁸ I *Kings* 7, 23, 25, 26, 46; Haynes 1992, 48.

¹²⁹ Maryon and Plenderleith 1954, 633-4.

¹³⁰ Lie 1929, 76-9; Dalley 1988, 104-5.

¹³¹ Dalley 1988, 104-5.

¹³² Langdon 1912, 72, 210, 282. Haynes (1992, 48) indicates that although most of these Near Eastern bronzes perished long before mercenaries and other visitors from Greece started to arrive in Mesopotamia at the beginning of the sixth century, it is likely that at that time they would have seen the Babylonian colossi, and that reports of them likely reached Greece.

¹³³ Thureau-Dangin 1912, 63.

¹³⁴ The sack of Musasir was represented on an Assyrian relief found at Khorsabad, since lost and now known only from a drawing by Flandin. (Botta and Flandin 1972, pl. 141).

¹³⁵ Maryon and Plenderleith 1954, 627, fig. 383; Lucas and Harris 1962, 222.

One of the largest bronze casts of the ancient world must have been the Colossus of Rhodes (290–280 B.C.).¹³⁶ The descriptions of the Colossus by several ancient authors suggest the height of the statue to have been 70 cubits, or about 32 m.¹³⁷ In an article published in 1956, Maryon suggests that the Colossus was constructed by the sphyrelata technique, using hammered sheet metal with a wall thickness of 0.17 cm.¹³⁸ Maryon based his study on the figure for the amount of bronze used of 500 talents (12.98 tons) given by Philo of Byzantium.¹³⁹ In a more recent study, using the size of the camel caravan that carried away the dismantled statue for recycling in A.D. 653 (900 camels with an estimated carrying capacity of 330 kg each),¹⁴⁰ Haynes re-estimated the amount of bronze used as 200 tons.¹⁴¹ Using Maryon's method of calculation,¹⁴² he calculated that the walls of the Colossus would have been at least 2.5 cm thick.

Philo's description shows that he believed that the only practical way to cast a statue of this size was in situ using horizontal courses, the first being cast on the permanent base, the second on the first, and so on to the uppermost level. In order to facilitate this casting method, Philo reports that the artisan heaped a massive mound of earth around each section as soon as it was completed, thus burying the finished work and providing a platform on which to carry out the casting of the next course.

Gabriel, in a technical study of Philo's text, reconstructed this method of production as follows: "Having completed the armature of the course to be cast, the bronze caster covered the iron lattice with a thick layer of clay, in which he brought the modeling to a finish. On this finished course he then formed a continuous set of clay

¹³⁶ For a general discussion of the Colossus of Rhodes, see Higgins (1988, 124-37).

¹³⁷ Plin. *NH* 34.18.41-2. Philo Byz. *De septem orbis miraculis* 4, in Haynes with translation (1957, 311; 1992, 121, n. 3).

¹³⁸ Maryon 1956a, 74-5.

¹³⁹ *De septem orbis miraculis* 4 See Haynes (1957, 312) for the primary source and a translation.

¹⁴⁰ Theophanes of Byzantium, *Chronicle*, 12.8.1.10.

¹⁴¹ Haynes 1992, 125.

¹⁴² Maryon 1956a, 74.

moulds and took them off again; after which he pared the course down to a depth equal to the thickness required for the bronze, thus converting it into the core. Finally he reassembled the moulds around the core and cast bronze in the intervening space.”¹⁴³ This construction method is further illuminated by a more recent record of the casting of the Great Buddha of the Todai Monastery in Nara, Japan, in A.D. 747-749. This piece represents the largest surviving cast bronze statue. This seated Buddha was originally 16.21 m high and weighs about 250 tons. Because of its size, it was cast, like the Rhodian statue, in situ in eight horizontal courses, poured one on top of the other with the aid of a progressively-built earth ramp to support the furnaces and the casting at each level.¹⁴⁴

Haynes speculates that the Colossus of Rhodes was not unique in its construction method and that other Greek colossi, constructed in a similar way, existed at this time as well as at earlier dates. The accounts for casting the Athena Promachus show that the furnaces used for this operation were built anew in each of the years for which records survive.¹⁴⁵ This suggests that the statue was not cast in the normal way, for in that case all of the sections would have been cast in the foundry at ground level, and the same furnace would have been used throughout. Haynes argues that the Athena was cast in situ in courses, for each of which a new working platform was created by progressively building up a mound of earth. This procedure, in turn, necessitated the repeated reconstruction of the furnaces. It would also explain why, as the repeated purchases of copper, tin, charcoal, firewood, clay and hair suggest, the casting operations were spread over most of the years it took to make the statue. This is in marked contrast with casting the Hephaestos and Athena for the Hephaesteum at Athens, the greater part of which seems to have been concentrated in a single year.¹⁴⁶ That the core of the Promachus may have been formed by paring the model, the most likely possibility if it was cast in courses, seems to be supported by the fact that there is no mention of wax before the

¹⁴³ Gabriel 1932, 338-40, figs. 1-2.

¹⁴⁴ Haynes 1992, 123-4, fig. 15.

¹⁴⁵ *JG I*³ 435.10-13 (restored), 42-45 (restored), 69-72 (restored), and 101-04.

¹⁴⁶ Harrison 1977, 141.

eighth year.¹⁴⁷ At this point it was probably needed to cast separately, by the direct lost-wax technique, details that were too isolated or too deeply undercut to be included in the main mold and were instead cast by the pared-core method.¹⁴⁸

In conclusion, the technology of melting and casting large quantities of bronze seems to appear first in the Near East and only later in the Greek world. The archaeological and literary evidence from the latter region confirms the existence of the technical knowledge to cast large bronzes (over 300 kg) in a single pour as early as the sixth century B.C.

¹⁴⁷ *JG I*³ 435.105. The use of a pared model together with refractory clay molds, as seen earlier (p.18, n. 48), did not require the use of wax.

¹⁴⁸ Haynes 1992, 126-7.

CHAPTER V

THE ATHLIT RAM: DESCRIPTION AND OBSERVATIONS

The following chapter presents a description of the Athlit ram based primarily on visual examination. In order to corroborate some of the observations and to interpret certain features, references are also made to data gathered by complementary methods such as radiography and chemical analysis.

General Description

The Athlit ram is a three-pronged waterline ram designed to encase and fortify the forward two meters of the bow of a warship. The ram's overall length is 226 cm, with a maximum width of 76 cm and a maximum height of 96 cm. It weighs 465 kg and is cast in bronze with a tin content of 9.78%, with lead and other elements only present at trace levels, i.e., below 1% (see appendix A, table 8). Radiographic analysis shows that the ram was cast as a single piece and also indicates the presence of several repairs and some internal features indicative of the method used in its production (appendix E). The ram can be divided into three functional parts: the driving center, the bottom plate, and the cowl (fig. 12).¹⁴⁹ A complete drawing of the ram is included in appendix D.

Driving Center

The 1.7 m-long driving center housed the main horizontal bow timbers and delivered the ramming blow through the head at its forward end. This impact area is composed of three robust fins merging to form a solid wall at the centerline of the ramming head. The head is 44.2 cm wide at the top and 42.6 cm wide along its lower edge, with a height at the centerline of 41.1 cm. The front wall of the ram's head is the thickest portion of the cast and was calculated to be 6.8 cm thick.¹⁵⁰

¹⁴⁹ The terms describing the various areas of the ram were first introduced by Steffy (1991, 11, fig. 2.7)

¹⁵⁰ Steffy 1991, 12. This section of the ram could not be directly measured due to heavy encrustation still adhering to its interior. Nevertheless, its significant thickness is manifested in the radiographic image taken at this location.

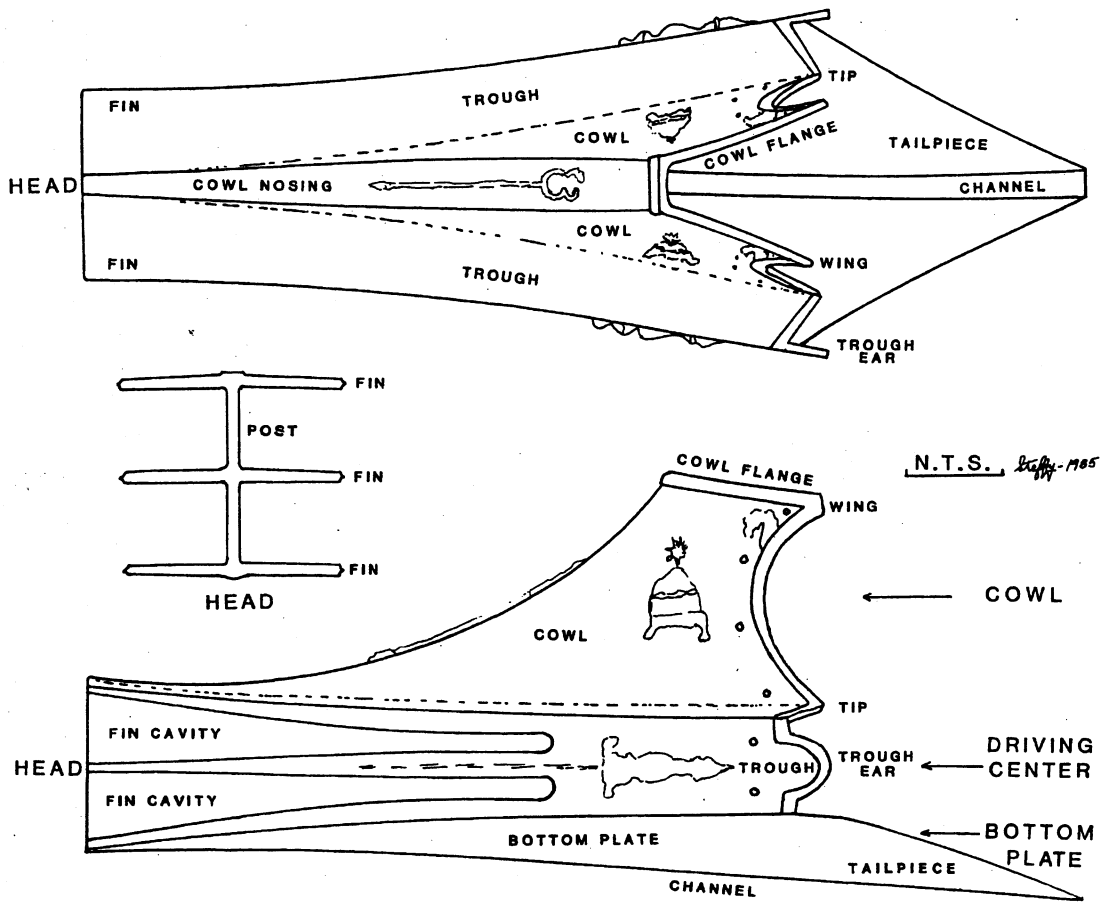

Fig. 12. Identification of the ram areas. Not to scale. (Steffy 1991, fig. 2.7)

The driving center decreases in height and increases in width toward the stern, forming troughs for the containment of a pair of wales. It is 30 cm high and 76 cm wide at its aftermost end. The sides of the wale troughs are reinforced by fins that extend horizontally from the ramming head toward the stern and transform into the thunderbolts that decorate the sideplates (see below). Two bolt holes are located at the aft end of each trough. The holes are slightly ovoid with a maximum diameter of 2.45 cm. Of the bolts used in the trough plate, only one has survived in good condition. It has a shaft 1.5 cm in diameter, with a convex head 2.5 cm in diameter, and 1.2 cm thick at the center.¹⁵¹ A comparison between the starboard and port trough sideplates shows marked differences both in dimensions and in overall design.

Bottom Plate

The bottom plate is an undecorated concave cover that protected the lower timbers. It has an overall length of 2.26 m. Beginning at the forward end of the ramming head, it assumes a characteristic curved shape 10 cm aft of the head, reaching a maximum width of 68 cm at the end of the wale sockets, and continuing aft for another 68 cm, tapering into a chisel-shaped end 6.5 cm wide. On its exterior, extending along the length of its centerline, the bottom plate carries a raised ridge. This ridge is raised above the surrounding surface to a height ranging between 0.4-1.6 cm, and has a width ranging between 4.0-6.5 cm. The corresponding inner surface of the bottom plate conforms to this element along most of its length, forming the bottom plate channel. The channel disappears 60 cm aft of the ramming head, at which point the interior of the bottom plate flattens out as it approaches the ram's forward end. Since the outer surface maintains the ridge structure throughout its length, the flattening of the inner surface results in a significant increase in thickness along the center of the plate. This in turn transforms the channel of the bottom plate into a solid bronze bar reinforcing the ramming head. Interestingly, the channel is not aligned with the centerline of the bottom plate, nor with that of the cowl. Instead, it curves to starboard. The bottom plate

¹⁵¹ This bolt, along with other fastening elements reportedly found within the ram, could not be located at the time of the current study. Their description is therefore based on Steffy's work (1991, 12).

tailpiece has two bolt holes on its starboard side, 18 cm aft of the trough ear. The innermost bolt hole is partially blocked by the repair to the tailpiece (see below). Directly opposite it, on the port side, were two similar holes that are now welded shut by the same repair. A fifth hole, now blocked with corrosion, is located in the bottom plate channel 25 cm forward of its aftermost end. The maximum diameter of the bolt holes in the bottom plate is 2.5 cm.

Four bronze protrusions are located on the exterior surface of the bottom plate. These are arranged in two corresponding pairs, one to starboard and the other to port, some 109 cm aft of the ramming head and 20 cm from the ridge on the bottom plate (fig. 13). The surface of these protrusions is irregular and their outline is roughly round. They rise above the plate surface to a maximum height of 0.8 cm. The purpose of these features is not entirely clear, although it is possible that they are the remnants of two lifting lugs, each pair once forming a closed loop. These could have been used to attach lifting tackle to haul the ram from its casting-pit.¹⁵² Interestingly, similar protrusions have been observed on a recently discovered bronze ram currently on display at the Piraeus museum.¹⁵³

Cowl

The cowl surrounded the vertical bow timbers. It consists of a flat nosing, that curves upward to meet the stem of the ship, and a pair of chariot-shaped sides, that flare outward along the hull's side planking. Four bronze bolts on each side affixed the cowl to the stem.

¹⁵² It is likely that Steffy's observation (1991, 39) of the bulging of the bottom plate, which he related to two nail heads found on the ramming timber, in fact are the remains of the lifting lugs described here.

¹⁵³ W.M. Murray, pers. comm., 1999.

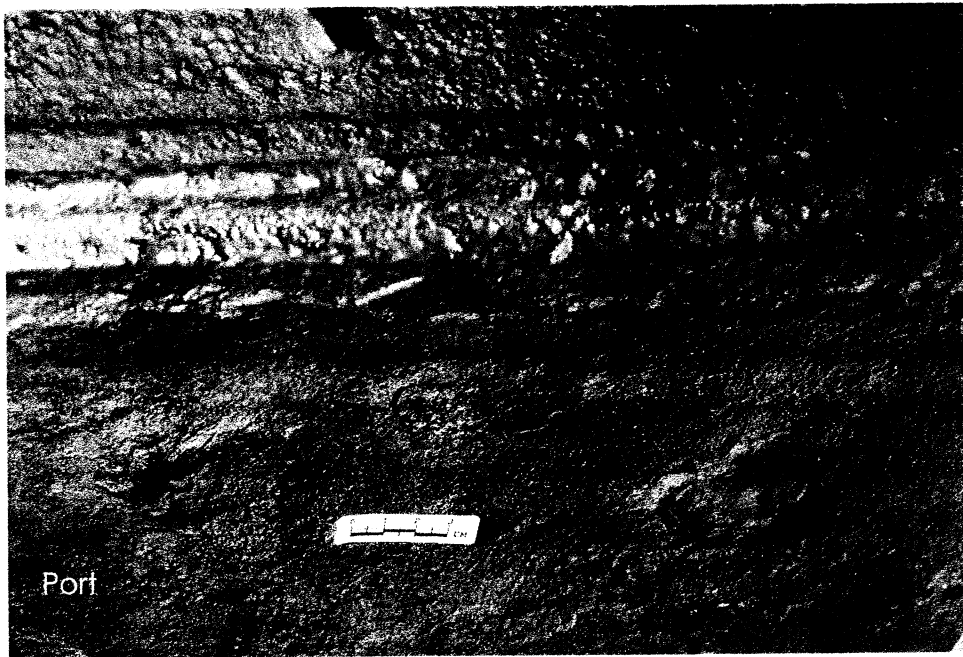

Fig. 13 The two pairs of protrusions on the bottom plate.
(Photograph by the author)

Like the trough holes, the bolt holes are slightly ovoid, with a maximum diameter of 2.5 cm. Two of the bolt holes (one on either side) are blocked by corrosion and the uppermost hole on the starboard side still contains the end of a bolt shaft (1.5 cm in diameter) and head (2.5 cm in diameter). In many cases, the inner surfaces and edges of the bolt holes have been disfigured by blow holes. Their asymmetric circumference suggests that they may have been cast, rather than drilled.

Decorations

The surface of the ram is decorated with four different symbols: an eagle head; a *pileus*, or helmet, surmounted by an eight-pointed star; a decorative handle device incorporated with the three fins of the ramming head to form a tri-form thunderbolt; and a *kerykeion*, or herald's staff, bound with a fillet.¹⁵⁴ The first three symbols are applied in pairs, one on each side of the ram, while the fourth decorates the cowl nosing. A feature common to all of these symbols is that the corresponding inner surface of each of the symbols does not follow the external design; instead, it maintains its flatness. Close examination of the pairs of symbols shows that they are positioned asymmetrically on the ram's surface and that there are often slight differences in their iconographic rendering. For example, on the starboard side, the handle device starts 5 cm closer to the trough ear than on the port side, while the port *pileus* is neither vertical nor aligned with its star, and its skirting and straps are off center. The starboard *pileus* is almost perfectly aligned and its strap has a different design. Similarly, the eagle heads vary in their rendering from one side to the other. Detailed measurements of the pairs of symbols (tables 3-5) show significant dimensional variation between the two eagle heads but nearly identical measurements for the handle devices. The *pilei* are also relatively identical with an underlying design that is almost uniform in its dimensions, although the superficial design elements, such as the straps, are not.

¹⁵⁴ See Murray (1991b, 54-66) for a discussion and interpretation of the symbols on the ram.

Table 3. Eagles; distance between points and elevation measurements.

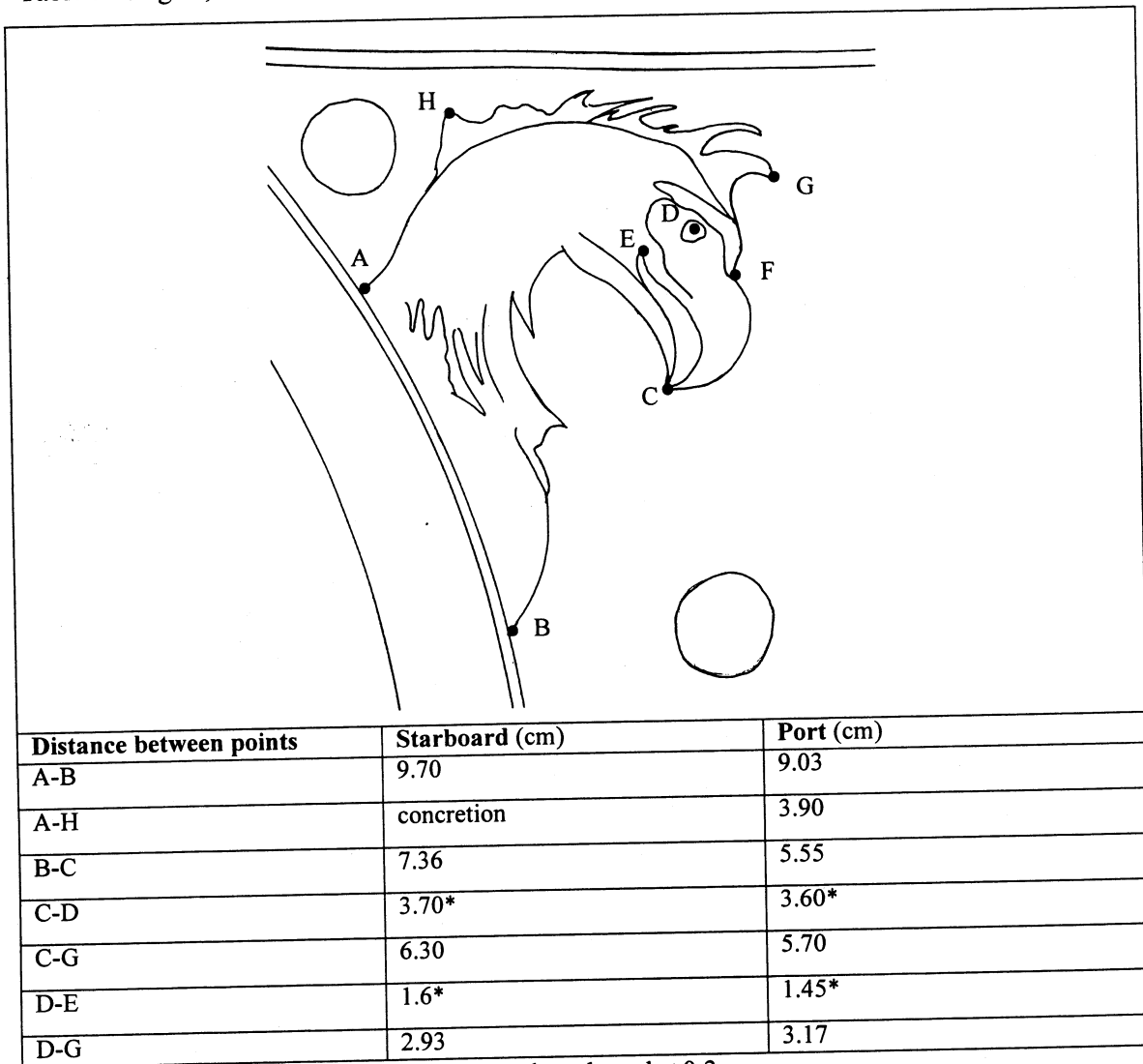

* Corresponding measurements on port and starboard ≤ 0.3 cm

Table 4. Pilei; distance between points and elevation measurements.

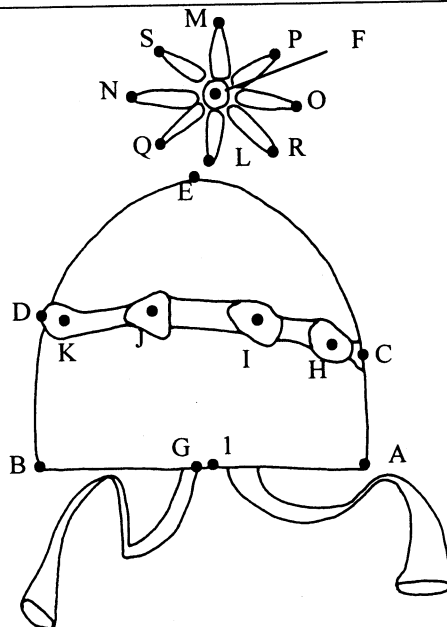

Distance between points	Starboard (cm)	Port (cm)
A-B	11.88 concretion	11.16
A-C	4.80 *	5.10*
B-D	5.00	4.67
A-E	11.96*	11.95*
B-E	12.70	12.30
G-E	10.96*	11.06*
H-I	3.50*	3.6*
I-J	4.18	3.4
J-K	3.0	point K does not exist on port
F-E	3.20	3.77
L-M	6.00*	6.00*
N-O	4.75	5.60
P-Q	5.00	5.67
R-S	3.91	5.80
Elevation at point		
1	2.2 concretion	1.70

* Corresponding measurements on port and starboard ≤ 0.3 cm

Table 5. Handle Devices; distance between points and elevation measurements.

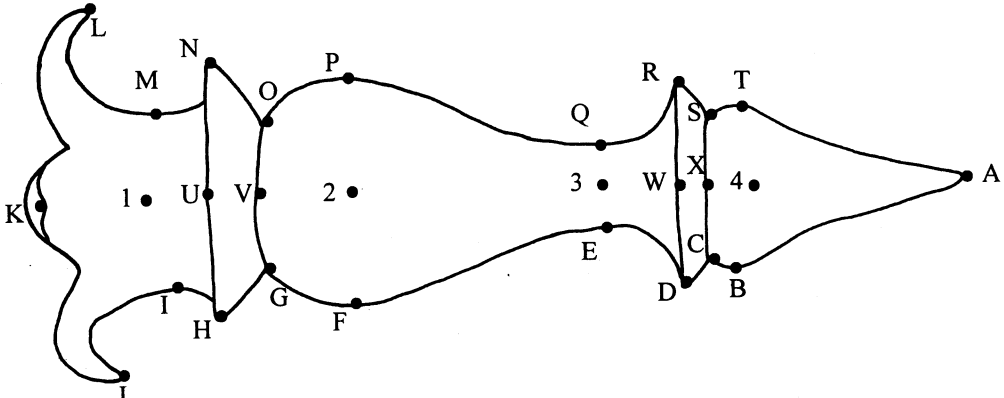

Distance between points	Starboard (cm)	Port (cm)
T-B	5.40 *	5.60*
S-C	5.50*	5.60*
R-D	5.46 concretion	6.8
Q-E	2.63*	2.66*
P-F	7.34* corrosion	7.52*
O-G	concretion	5.76
N-H	concretion	8.68
M-I	concretion	6.10
L-J	concretion	12.30
K-U	5.5	6.05
U-V	1.77*	1.70*
V-W	14.50*	14.20*
W-X	0.72*	0.70*
X-A	7.40	8.60
Elevation at points		
1	concretion	3.00
U	4.50*	4.50*
V	concretion	2.60
2	4.20*	4.20*
3	1.80*	1.60*
W	4.20*	4.20*
X	2.90	3.30
4	3.60*	3.50*

* Corresponding measurements on port and starboard ≤ 0.3 cm

The dimensional correlation of these two symbols on an object that otherwise exhibits a lack of symmetry suggests that they were not modeled freehanded. Instead, they were most likely formed mechanically using a single mold in which a wax inter model was made and subsequently attached to the primary ram model in order to be cast integrally.¹⁵⁵ The suggestion that these pairs of symbols were added at a later stage of the modeling is further corroborated by their asymmetrical positioning on the ram. Evidence for the use of molds as templates in bronze casting are known elsewhere. A large group of plaster molds at the Cairo Museum (most likely dating to the first century B.C. and originating from Saqqarah and Memphis) were used as templates for the repetitive manufacture of bronze statues, lamps, candelabra, tripods, and various other utensils using the indirect method (fig. 14).¹⁵⁶ It is easy to imagine such molds being used to form the handle devices or pilei seen on the ram.

Wall Thickness

The wall thickness of the ram was measured by Steffy at 24 locations and was found to range in most areas between 0.7–1.0 cm.¹⁵⁷ The flanges, ribbing, fins, and the area around the head are significantly thicker. Additional wall thickness measurements taken during the current study along the ‘ceilings’ of the troughs, near their junction with the trough sideplates, and along the bottom plate near its junction with the trough sideplates, indicate longitudinal variations in wall thickness ranging from 0.7-3.5 cm along the ceilings and between 0.9-3.5 cm along the bottom (fig. 15). There is an overall increase in wall thickness towards the ramming head; however, the thickest points along the ceilings are 2.5 cm on the starboard and 3.5 cm on the port, some 150 cm and 180 cm forward of the ram’s aft end, respectively. Along the bottom plate the thickest points

¹⁵⁵ See Haynes (1981, 136-7) and Mattusch (1994, 796-7) for a discussion of the use of detailed measurements in the comparative study of cast bronzes.

¹⁵⁶ Edgar (1975, I-xiii, pl. XVII). See Rolley (1986, fig. 202) for a plaster mold dated to 100 B.C. whose contours and dimensions are somewhat close to the design of the handle devices on the ram.

¹⁵⁷ Steffy 1991, 11.

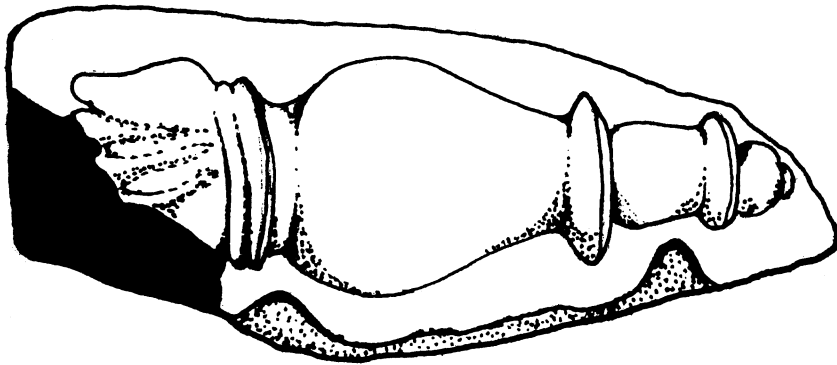

Fig. 14. Plaster mold fragment from the Cairo Museum. The fragment is half of a bipartite mold, made (with the exception of the calyx) on a wheel-turned model. Dimensions: length 18.0 cm, width 8.0 cm. (After Edgar 1975, pl. XVII, 32245)

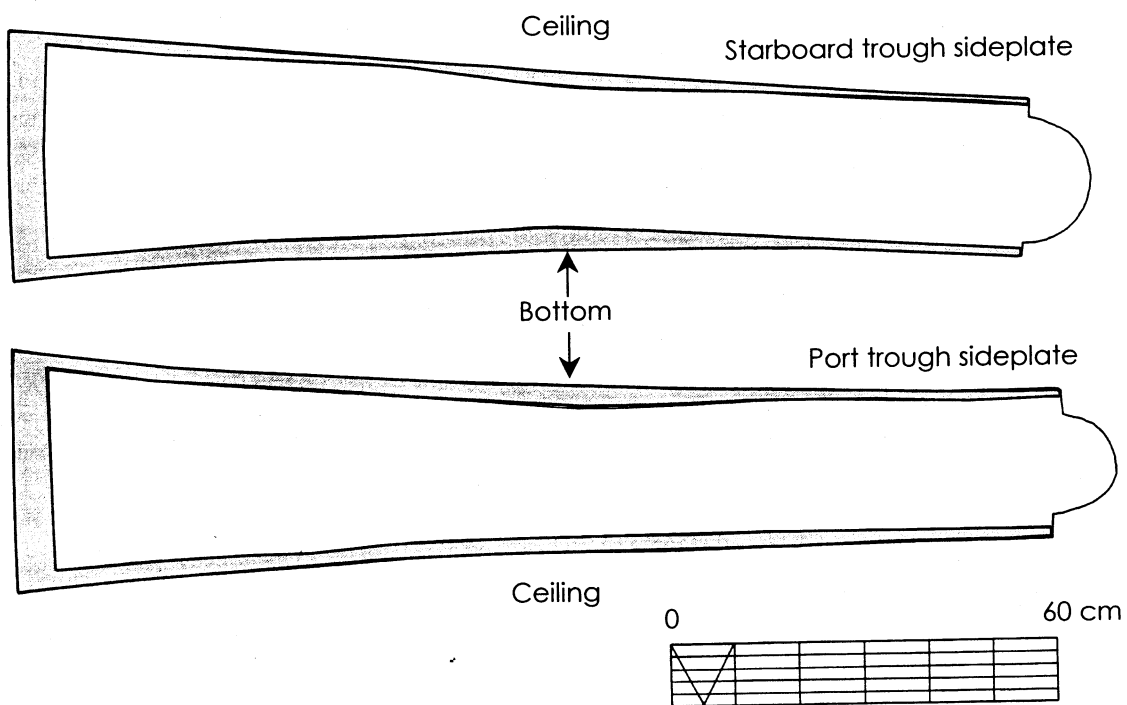

Fig. 15. Cowl ceiling and bottom plate wall thickness. The cross sections show the ram cowl ceilings and bottom plate wall thickness at their junction with the trough sideplates. (Drawing by A. Schreur and the author)

are 4.1 cm on the starboard and 3.5 cm on the port measured 150 cm forward of the ram's aft end. Variations in wall thickness are also clearly evidenced through the radiographic analysis, which indicates several zones of reduced wall thickness. The most noticeable of these are seen throughout the bottom plate (see appendix E). An increase in opacity is observed in the radiograph forward of a faint line, also seen in the radiograph, traversing the bottom plate 125 cm forward of the aft end of the ram. This mark, which is clearly visible to the naked eye, assumes the form of a step on the bottom plate inner surface with a vertical height of 0.5-0.8 cm (fig. 16). Its width ranges between 0.2-0.7 cm and its depth between 0.1-0.3 cm. Since the exterior of the bottom plate retains its contours throughout its length, the step results in a considerable increase of the thickness of the bottom plate forward of this point. The mark itself extends, in a less pronounced fashion, over the rest of the ram's inner wall, with the exception of the fin channels, where it is temporarily obliterated, and disappears under the concretion that covers the cowl nosing. Two additional transverse marks, somewhat fainter than the former, cross the inner surface of the bottom plate 20 cm forward of the first mark and 5 cm aft of it, but none extends to the side walls. An additional set of recessed marks begins at the main transverse mark and extends forward at an oblique angle towards the bottom plate channel (fig. 17). These marks are often composed of broken parallel lines. A faint remnant of a vertical line can be seen, under raking light, on the exterior surface of the starboard cowl plate and in the radiograph, a few centimeters forward of the main mark on the inner surface. The relationship of this mark to the inner marks is unclear. In order to establish the origins of the marks on the interior surface, the ramming timbers were visually examined to identify a possible relationship between features on their surfaces and those found on the bronze. Although no corresponding marks were found on the timbers that can explain the transverse marks on the interior of the ram, some correlation of geometry was observed between the underside of the ramming timber and the oblique lines and contours on the bottom plate. The bottom of the ramming timber has a set of longitudinal faceted planes, only partially visible in Steffy's drawing (fig. 18).

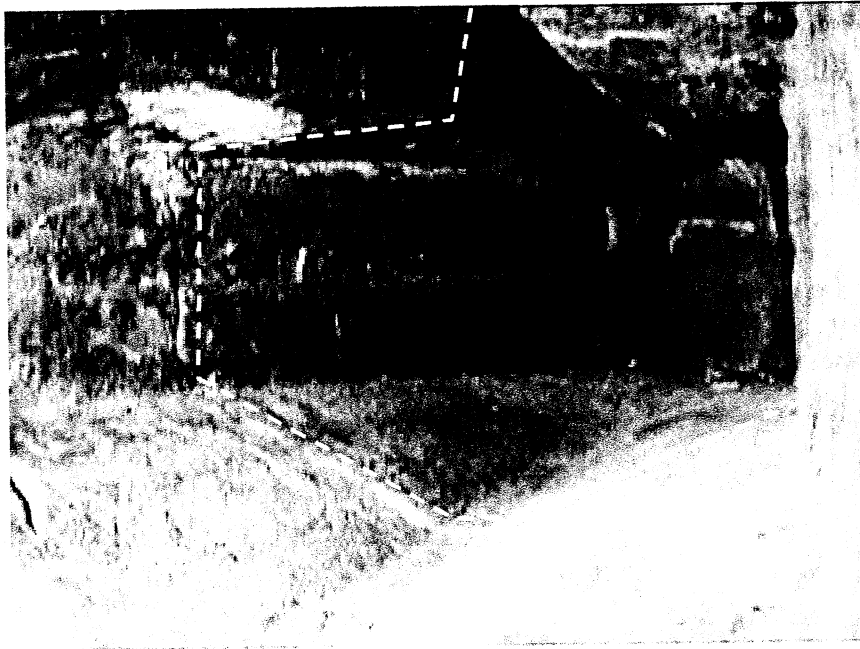
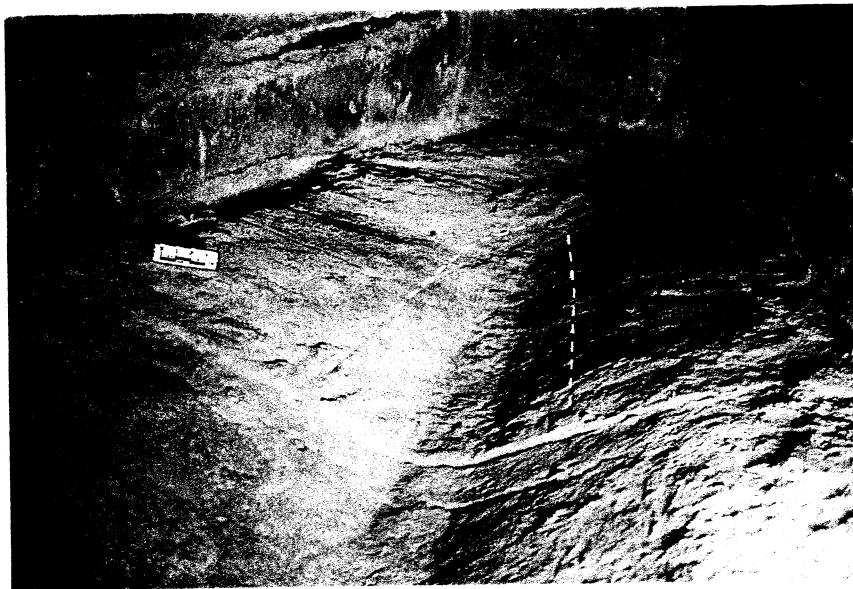

Fig. 16. Transverse mark on the bottom plate and sides of the ram.
(Photograph by the author)



17. Oblique marks merging into the bottom plate channel. (Photograph by the author)

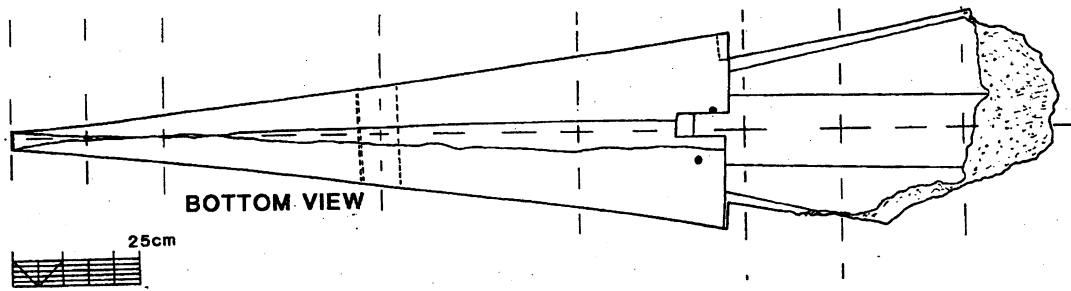

Fig. 18. A view of the bottom side of the ramming timber. (Steffy 1991, fig. 2.24)

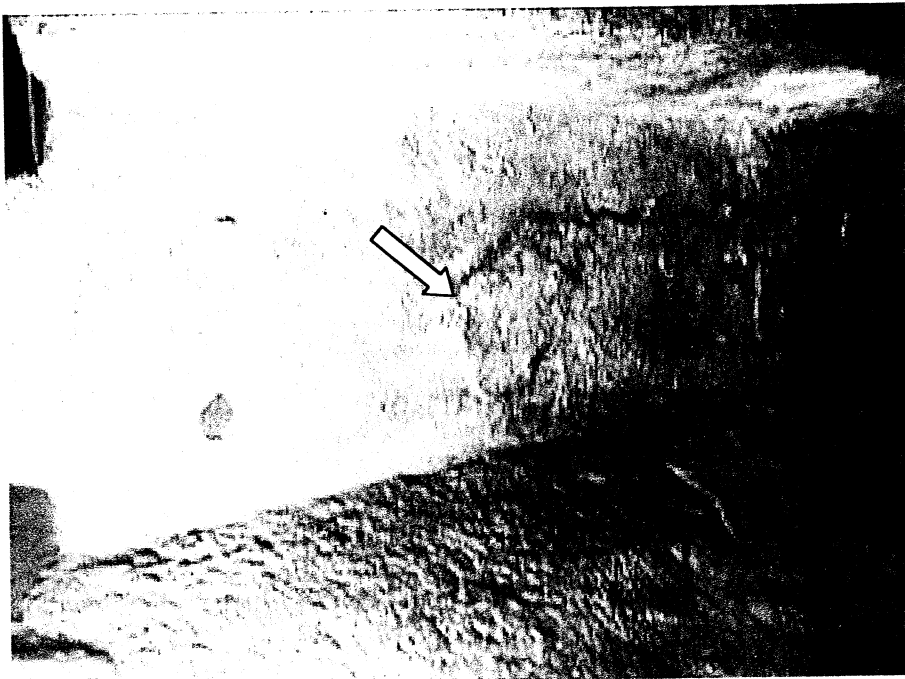

Fig. 19. Surface irregularity on the port trough sideplate.
(Photograph by the author)

The dimensions and orientation of these correspond with the oblique grooves on the bottom plate and with the overall shape of this section of the bottom plate. Furthermore, the facets on the ramming timber flatten out some 60 cm aft of the timber's forward end, as does the matching section of the bottom plate. The diagonal marks that correspond roughly with the faceted planes merge with the bottom plate's centerline at about the same location. This observation points to an intimate relationship between the ramming timbers and the construction of the ram. It suggests that the Athlit ram was made specifically for the bow of this ship by means that closely replicated the bow's geometry in the bronze cast. This possibility will be discussed in further detail in the following chapter.

The interior surface of the ram generally follows its external shape, with the exception of the bottom plate channel and the symbols, the underside of which is flat. An irregularity in the wall thickness is observed on the inner wall of the port side trough plate, opposite the aft end of the handle device, where a section of the wall bulges out, creating an area of increased wall thickness. This feature has no defined geometry and its angular boundaries may indicate a break and the displacement of the core material prior to the casting (fig. 19).

Fin Channels

The inner surfaces of the sideplates of the troughs are marked by three channels located at the reverse of each of the fin protrusions (fig. 20). These channels are widest at their midsections, and their forward ends terminate in narrow tips that range in distance from the inner wall of the ram's head. Their aft ends are rounded. The middle fin channel on each side resembles a trench cut into the solid wall. The edges between the vertical planes of the troughs and the horizontal surfaces of the channels range inconsistently in their angles, in some cases forming an angular corner and in others forming rounded or oblique transitions. The ceiling of the top fin channels and the floor of the lower fin channels are on the same level as the adjacent trough ceiling and bottom plate floor, thus forming a continuous horizontal plane.

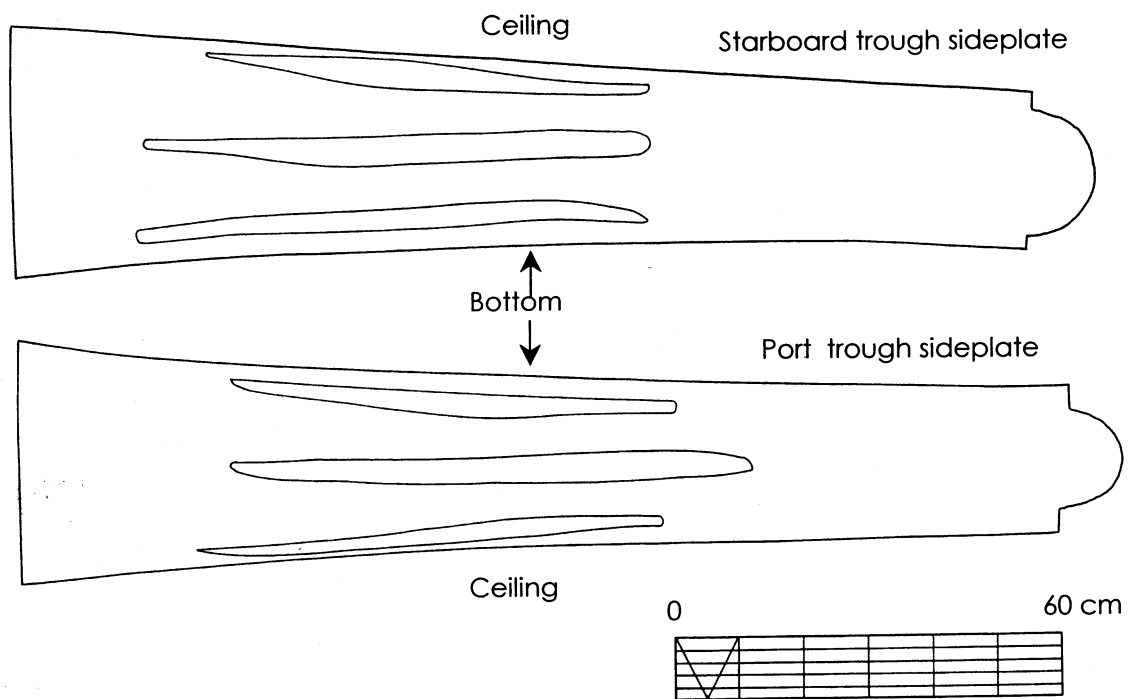

Fig. 20. The interior of the sideplates showing the arrangement of the fin channels and their asymmetric nature. (Drawing by A. Schreur and the author)

Interestingly, the trough ceilings often hang lower than the opening of the top fin cavities, as if they had sagged after the channel was formed.

Chaplet Holes

A series of square holes, averaging 0.4 x 0.4 cm, mark the fin cavities on the port side, beginning at the ramming head and extending along their length. These are often blocked with reddish-brown iron rust. A similar set of holes exists on the starboard side, where their presence under the concretion still covering this section is indicated in the radiographs. The sets of holes on the starboard side do not correspond precisely to those on the port side. The examination of the wale timbers by Steffy showed no matching holes in the wood that would suggest that the holes in the bronze were used for fasteners;¹⁵⁸ these observations were confirmed during the current study. In addition, none of the holes passes through the corrosion layers adhering to the inner surfaces of the ram, indicating that fasteners were not driven through these holes. Finally, the radiographic analysis of the ram reveals many more holes of similar appearance and distribution over the entire surface of the object (see appendices E and F). In many instances, these holes are clearly visible to the naked eye, particularly on the interior surfaces of the ram. The square cross section of the holes and the iron oxide found in some of them, along with evidence from other cast bronzes, suggests that they are chaplet holes systematically distributed throughout the ram.¹⁵⁹ Probing of the chaplet holes with a long needle indicated that only a few traverse the bronze walls. In most instances the needle, having been inserted from the inside outwards, stopped a few millimeters short of the ram's outer surface. A close examination of the radiographs showed that many of the holes were masked on their outer ends by small rectangular bronze patches (fig. 21).

¹⁵⁸ Steffy 1991, 32.

¹⁵⁹ See Ridgway (1987, figs. 5.66-7, 5.69) for examples of square chaplet holes in bronze statue fragments. See Willer (1994, 964, fig. 1) for a radiographic image of square chaplet holes on the surface of a bronze herm.

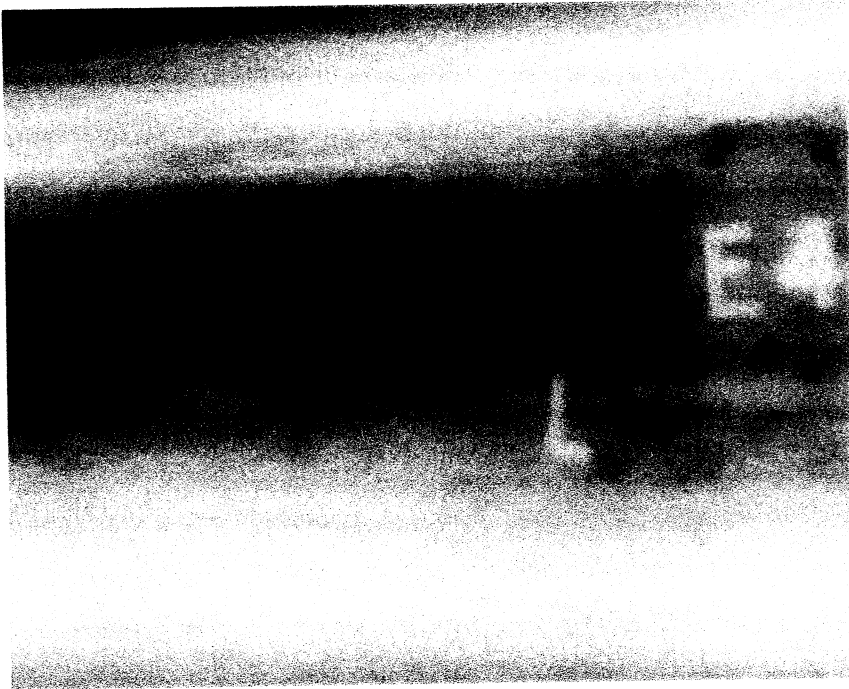

Fig. 21. Repair patch over a chaplet hole on the ram. This photoradiograph, taken at the cowl nosing, shows a chaplet hole overlaid by a bronze patch. (Phtoradiograph by the author)

Similar masking of chaplet holes has been observed on many Classical and Hellenistic bronzes; in most cases the repairs appear to have been cosmetic.¹⁶⁰ Interestingly, it appears that no attempt was made to patch the chaplet holes inside the fin cavities while other casting faults, presumably also below water line, such as those on the ramming head and fin, have been patched. One possible explanation for this lack of consistency may be the difficulty of applying patches inside the fin cavities due to the curving surfaces and the relative inaccessibility of the area between the fins. In some instances, chaplet holes were located underneath decorative elements such as pilei and handle devices. The extent to which these chaplet holes penetrate the decorations provides information regarding the construction sequence and whether or not they were cast as an integral part of the ram or as subsequent additions. Assuming that the chaplet holes under the decorations were part of the initial casting of the ram, they would extend into the superimposed decorations only if the latter were cast integrally with the ram itself. In the alternative option, that of casting the symbols as additions after the main cast was completed, these holes would be expected to traverse only the wall thickness of the walls of the ram and to terminate under the decorations. Probing the chaplet holes under the decorative elements showed that they traverse beyond the ram's main wall (estimated in these locations to be 1 cm thick) and extend into the decorative elements, which indicates that they were cast with the ram. An additional indication of the integral casting of the decorations with the ram comes from the chemical analysis of the two handled devices and one pileus, all of which have an alloy composition identical to the ram's main cast. In contrast the analysis of added elements such as patches and cast on repairs showed that they have a different composition than the ram's main cast (see appendix A, table 8 for chemical analysis data). These findings are compatible with the earlier discussion of the production sequence used to cast these symbols.

¹⁶⁰ Oliver-Smith 1975, 98; Ridgway 1987, 71; Haynes 1968, 112; 1992, 71; Willer 1994, 965-7, figs. 11, 13-14.

Surface Quality

The surfaces of the ram vary greatly in quality, ranging from compact and smooth to deeply pitted and disfigured areas. These variations seem to result from a combination of corrosion, casting faults, and probable erosion during burial. Highly compact, smooth surfaces are most common over the forward ends of the troughs and cowl, and in areas such as the fin cavities on the starboard side. In between these well-preserved surfaces, there are areas of extensive surface damage (fig. 22). The inconsistency of the surface quality of the forward sections of the ram may be the result of an uneven buildup of marine concretion and subsequent corrosion only in the exposed areas. The aft portions of the cowl exhibit the highest levels of surface loss observed on the ram. The reason may be an accelerated corrosion rate and surface loss due to increased casting porosity in this area (see appendix E).

Evidence of Use, Casting Faults and Repairs

There is little indication of usage on the Athlit ram. Such evidence is limited to minor damage to the tips of both bottom fins, and the tip of the starboard middle fin. The outboard ends of the upper fins curve downwards about 0.8 cm from the horizontal plane; the central and lower fins are depressed about 0.4 cm but it is possible that they were cast this way. More obvious damage to the ram seems to derive from casting faults, visible primarily on the exterior surfaces. These include incompletely cast areas, cracks, and large blow holes. In at least three locations, blow holes in the cowl area penetrate the entire thickness of the ram's wall. An additional large hole (approx. 1.5 x 1.5 cm) is present under the concretion that covers the forward end of the starboard trough sideplate between the middle and the lower fins. Its location is indicated in the radiographic image (see appendix-E)

The surface of the port side of the cowl is cracked in two locations. The deeper crack extends diagonally from the port cowl flange towards the pileus, where it terminates in a bronze patch.

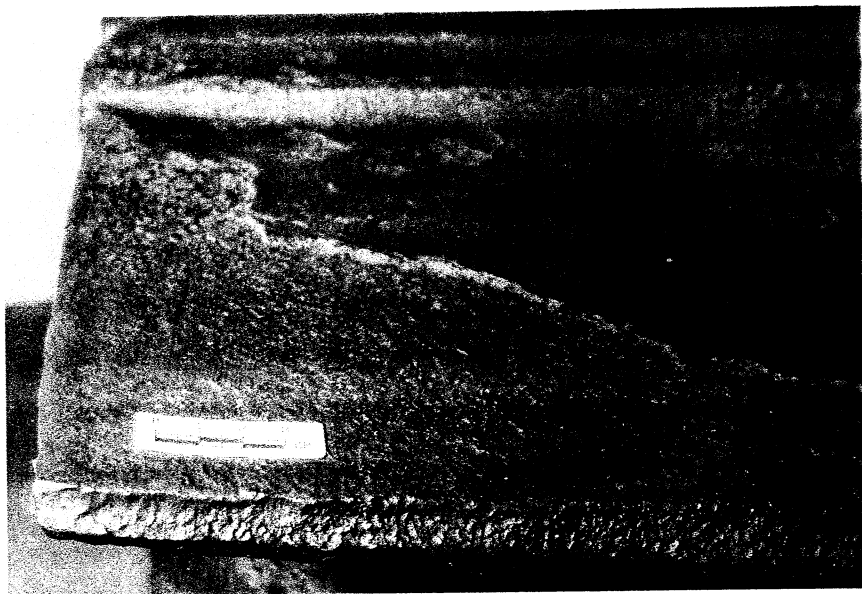
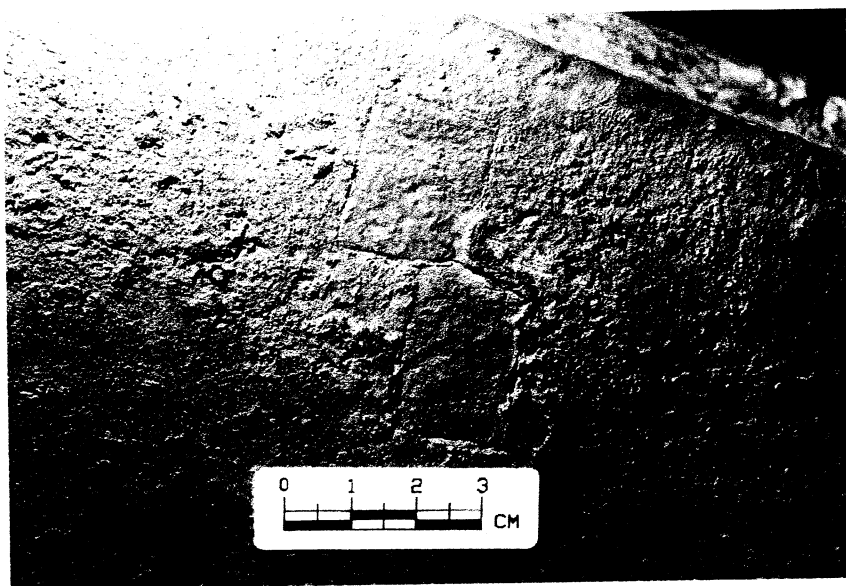

Fig. 22. Variations in surface quality at the area of the ramming head.
(Photograph by the author)

The appearance of these cracks suggests that they are related to the casting process and that they may be the result of shrinkage or an interruption during the pour. Incompletely cast areas are evident in several locations, all of which are concentrated in the aft sections of the ram. To starboard, these include the starboard tip and its adjacent areas along the aft edges of the cowl arch and trough. On the port side, portions of the lower section of the cowl arch and tip are damaged, as well as a section of the trough ear. About 3 cm of the cowl wing's tip is also missing on this side and was most likely incompletely cast. The largest of this group of casting faults, however, is the tailpiece. Currently constructed of a large cast-on element, it appears that this part of the ram was incompletely formed during the initial casting and was therefore replaced shortly afterward with a new piece.

The concentration of the majority of the casting faults along the aft end of the cowl corresponds with the high concentration of blow holes in this area, where they form a belt that encircles the entire aft end of the ram. This evidence hints at the orientation of the mold in the casting-pit and suggests that the mold was positioned vertically, head down in the pit (see fig. 7). This orientation would explain the accumulation of gas bubbles in the aft sections of the ram, and the incomplete casting of the ram's upper sections, possibly due to the trapping of air in the upper extremities of the mold, which prevented them being completely filled by the rising metal.

With the exception of the tip of the port wing, all the other large casting faults were repaired in antiquity either mechanically or metallurgically. Mechanical methods were used primarily to hide small casting faults and chaplets holes, while metallurgical methods were applied to casting faults too large or too complex to be patched. Mechanical repairs consist of rectangular bronze patches wedged into shallow undercut square holes and are seen at several locations such as on the lowest starboard fin, on the ramming head, and on the cowl (fig. 23). These repairs are often so well executed that they can only be detected through radiographic analysis. The position of an additional repair patch measuring 2.5 cm in diameter may be indicated by a small groove at the center point of the ramming head. The presence of a repair at this location could not be



A

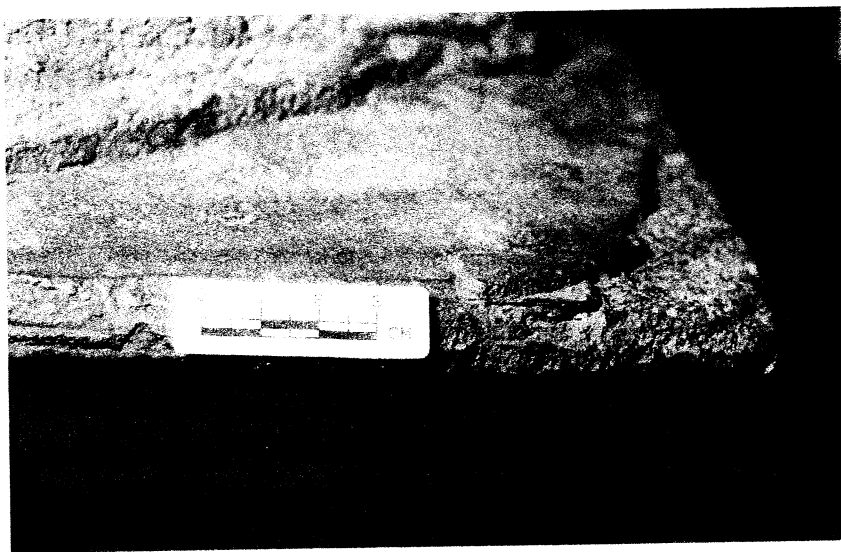

B

Fig. 23. Casting faults repaired with patches: *A*, pair of patches on the cowl starboard side; *B*, repair patch on the starboard lower most fin. (Photograph by the author)

revealed conclusively by visual or radiographic examination. However, the presence of some type of flaw in this area was noted by Steffy during the initial study, when water inside the ram escaped through this area as it was lifted out of its storage tank.¹⁶¹ Metallurgical repairs, with the exception of the tailpiece, are in the form of cosmetic cast-on repairs applied in places where large casting faults had occurred. On the starboard side, cast-on repairs were used to reconstruct the lower border and tip of the cowl arch (fig. 24). On the port side, a similar repair makes up the lower third section and tip of the cowl arch and the upper section of the trough ear. In all three cases, the repairs roughly follow the decorative features of the ram. Inside the ram, the repairs extend over a greater area than they do on the exterior, and their surfaces are often slightly recessed. In contrast to the surfaces surrounding them, the repair surfaces are smooth and contain no blow holes. All three repairs are clearly evident in the radiographs due to their higher opacity, which may be due to their higher lead content (see appendix A, fig. 29, and appendix E).

The largest metallurgical repair on the ram consists of the entire tailpiece (fig. 25). This repair is connected to the original cast 51 cm forward of the ram's aft end. The join appears to the naked eye as an irregular line with a partially plugged bolt hole on the starboard side and with three or four additional small cast-on patches on its port end. These patches may indicate that the repair did not join fully to the main cast and required subsequent cast-on additions. The radiographic analysis of the join reveals further information on the nature of this extensive repair operation (see appendix E). Low opacity at areas along the interface between the cast-on piece and the primary cast of the ram attest to the partial bonding between the two elements. The radiograph also suggests the application of additional metal to reinforce the initial join. On the port side, the small additional patches can be clearly seen, and in the center a wedge of metal appears as a filler applied into the interface. In addition, the radiographic image shows a clean, stepped edge on the ridge/channel parts of the main cast bottom plate.

¹⁶¹ Steffy 1991, 15.

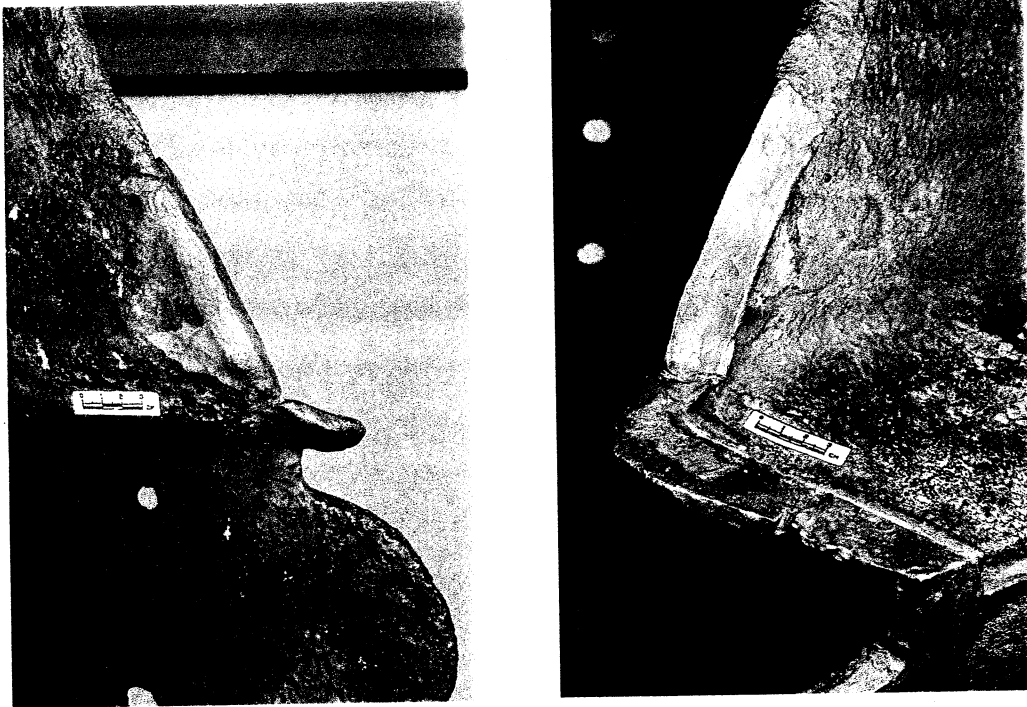

Fig. 24. Cast-on repair on the starboard tip and border of the cowl, seen from the exterior (*Right*), and interior (*left*) surfaces. (Photograph by the author)



Fig. 25. The repaired tailpiece joint. (Photograph by the author)

This suggests that it was mechanically worked or trimmed before the casting of the repair to better receive the cast and to provide some mechanical interlocking between the two elements.

Finally, one might wonder at what stage the tailpiece was repaired and whether or not this was done soon after the original casting or as a result of breakage during use. The alloy composition of the repair is clearly different from that of the primary cast (see appendix A, fig. 29); however, this does not necessarily imply a later casting, but merely the use of a different alloy batch. An examination of the distribution of chaplet holes in the repair, seen in the radiographic image, shows that they follow the same pattern seen on the main cast. This may imply that the repair was made soon after the ram's initial casting and that the bronze worker followed the chaplet pattern on the main cast. This observation, combined with the perfect alignment of the repair with the rest of the cast, suggests that it was repaired immediately after the main cast was finished. It also implies that the bronze caster may have modeled the repair using parts of the original mold, core, and chaplets, prior to their full removal.

CHAPTER VI

THE CASTING OF THE RAM: DISCUSSION

Our knowledge of Classical and Hellenistic large-scale bronze casting techniques is based almost entirely on surviving statues and the archaeological debris associated with their production. Consequently, any postulation regarding the casting of the Athlit ram must rely on the possible technical options currently known from the study of statues and other decorative bronzes, in comparison to the features found on the ram itself. The examination of the ram shows many similarities in workmanship in terms of repairs, chaplets, wall thickness, and alloy composition between the ram and other large-scale bronzes of Classical and Hellenistic dates. However, in order to interpret the casting of the ram correctly, the ways in which it differs from contemporary decorative bronzes must also be considered. The differences stem directly from the ram's unique function as an impact weapon designed to fit onto the bow of a warship and to deliver a crushing blow to an enemy vessel. In order to fulfill these physical requirements, the ram was cast as a single unit, despite the complexity of handling and casting large quantities of molten bronze. The alternative method of construction commonly used in contemporary bronze sculpture, which uses separately cast units assembled by mechanical or metallurgical means, could not be used on the ram as it would have resulted in a significantly weakened structure unsuitable for its function. Furthermore, unlike decorative bronzes where little attention was paid to interior geometry, the ram's cavity had a functional role, i.e., it had to fit perfectly onto the bow timbers and therefore needed to be configured to given dimensions. Indeed, there is now sufficient evidence to suggest that the bronze worker modeled the ram directly on the bow to ensure a close match between its cavity and the bow timbers.

Steffy, who first suggested that the ram was made specifically for the bow of a particular ship, pointed out several instances in which features on the ram correlate closely with the timbers found within it. He observed that the curve of the cowl nosing carried the same irregularity as the nosing piece beneath it and that the dimensions of the

ramming timber and the angles of the wales in the area of the stem were faithfully duplicated in the casting.¹⁶² The evidence gathered during the current study corroborates Steffy's initial observations and further suggests that the initial model of the ram was constructed directly on the bow timbers of the ship.

Possible Production Methods

The forwardmost inner section of the bottom plate closely follows the contours found on the ramming timber. This replication of the timber contours terminates 125 cm aft of the ram's head, where a sharp decrease in wall thickness is marked by a transverse mark across the bottom plate. The latter transforms into a shallow groove on the trough walls and extends vertically all the way to the cowl nosing, where it disappears under the concretion still covering this section. The groove crosses the fin channels only on the port side (to starboard it passes aft of their ends) at which point it is obliterated by the channels. Additional transverse grooves mark the bottom plate forward and aft of this point; however, they do not appear to extend to the side walls and are not as pronounced as the main groove (see figs. 16, 17). Marks of similar appearance have been observed on other ancient bronzes, where they are normally associated with the seam lines between wax or clay slabs used in the construction of the model.¹⁶³

A collective explanation for the range of surface features described above, and their relationship to one another and to the bow timbers, may hold the key to understanding the casting method employed. Such analysis requires an overall review of the various production methods available to the ancient bronze caster and the identification of the characteristic features associated with each method.

The detailed survey of Classical and Hellenistic bronze casting practices provided in chapter 2 indicates that the primary techniques used by Greek bronze casters fall into two main categories: direct and indirect casting. These techniques can be used

¹⁶² Steffy 1991, 38-9.

¹⁶³ For examples of seam lines on other bronzes see Haynes 1960, 46, pl. 20.1; 1968, 107-8; 1992, 35, pl. 3.

to cast solid bronzes or, with the introduction of a core, hollow casts. Since the Athlit ram is a hollow cast, the techniques that will be discussed here are *hollow casting by the direct method* and *hollow casting by the indirect method*.

A quick look at figures 4 and 5 indicates an array of possible ways in which the ram could have been cast. However, the range of options can be narrowed if it can be shown that the features found on the ram indicate the following:

- A. The model of the ram was constructed on the bow of the ship in order to allow for the replication of the timber geometry in the bronze.
- B. The model was constructed, at least in part, of separate modeling units such as clay or wax slabs that left seam lines on the interior surfaces.
- C. The model was given a refractory core after it was fully shaped, as only by this sequence could the seam marks between the modeling units be transferred from the model to the bronze cast.

With the help of the flow charts, and taking into consideration the above restrictions, it is possible to hypothesize on the production sequence of the ram. Beginning with the inner cavity, it is first necessary to evaluate which method best explains the construction of a casting model with an interior that replicates a preformed object, such as the bow timbers of a ship.

In order to produce the ram using hollow casting by the indirect method, the bronze caster had to first construct a solid model of the ram (made of wood, clay or any other modeling medium) from which a negative was created using a piece mold. Employing various techniques to obtain an inter model (or positive model) from the mold, the ram could then be replicated numerous times in bronze. In general, the indirect method uses the model-negative imprinted in the mold as the starting point of the process and builds from the surface of the mold inward. In the 'inter model first' option (A_1) an inter model is obtained through lining the primary piece mold with wax or clay. If wax lining is used in a primary plaster piece mold (c), the mold will be removed after the coring and the inter model invested with a secondary mold of refractory clay followed by casting (i).

If a wax lining is used with a primary refractory piece mold (*h*), casting can proceed directly after coring.¹⁶⁴ If clay lining is used (*d*) with a primary plaster mold (*j*), the lining will be replaced with wax after coring. The plaster mold is then removed and the inter model invested in a secondary refractory mold and cast. If clay lining is used with a primary refractory mold (*g*), the casting can proceed immediately following coring and the removal of the lining.

In the 'core first' option (*B₁*), a core must be constructed that follows the shape of the model of the ram as closely as possible, in order to maintain even wall thickness in the cast. The core can be formed by pouring a refractory clay mixture into the mold and then paring it down to the desired thickness of the bronze wall (*e*). Alternatively, the core can be built in clay in the approximate shape of the model, leaving a uniform gap between the mold and the core to accommodate the bronze (*f*). If the primary mold is of plaster (*k*), wax is poured into the gap between the mold and the core and the mold is replaced by a secondary mold of refractory clay. If the primary mold is of refractory clay (*l*), the casting proceeds directly in this mold with no use of wax.

The 'inter model first' option (*A₁*) poses a problem if the inner cavity needs to fit a prescribed shape, such as a ship's bow. Lining the mold first means that the bronze caster would then have to find a way to shape the model's inner walls to reflect the shape of the bow timbers. It is difficult to imagine how, once lined, the mold could be fitted on the horizontal bow in order to have its timbers imprinted into the lining material. Possible solutions to this difficulty may have been to use a multi-piece mold in which each section could be lined separately and pressed against the bow to register its contours. Otherwise, the empty mold sections could be held against the bow timbers at a controlled distance and the wax poured in. Whichever method was used, the bronze caster would have then faced the cumbersome job of assembling the separate wax

¹⁶⁴ The use of primary refractory piece molds is presented here for discussion purposes, since it was an option that would have been available to the bronze caster. However, the complications associated with using refractory piece molds, such as metal seepage between the mold parts and the shrinkage of the mold during firing, were major disadvantages and it is unlikely that it was commonly used for such large objects (p. 18, n.46).

sections into one continuous object, a process that would have left additional join lines to those found in the ram's interior. The construction of the core prior to the inter model, on the other hand, as in the 'core first' option (*BI*), implies that the core had to be handmade to the exact geometry of the bow and then fitted with the mold. To achieve this, the craftsman would have had to either curve the solid core (*e*) or free model it in clay (*f*) to the exact shape of the bow. In addition to being a time consuming process, this method would have presented the worker with the difficult task of manipulating a solid core weighing hundreds of kilograms through the various production steps, including the transition to the casting-pit.

Considered next is the production option of 'hollow casting by the direct method' in which the model would be built freehand in wax directly on the core and then invested and cast. In order to conform the shape of the ram's inner cavity to that of the bow geometry, a preformed core had to be made to the exact shape of the bow. This could be achieved either through sequence *B*, by building the core to the exact shape of the bow and then constructing the model on it, or more easily through sequence *A*, by constructing the model directly on the bow. Manually building the core to the exact shape of the bow (*B*) would have presented the bronze caster with the same complications discussed above under options *e* and *f*. These difficulties could be avoided by using option *A*, which offers a mechanical means by which the bow geometry can be replicated in the model. By building a wax model on the bow, using the bow as the temporary non-refractory core, the bronze caster could replicate the bow geometry in wax with minimum labor. Once the model was completed, it could be slipped off the bow and filled with a secondary core of refractory clay.

Our discussion has so far focused primarily on the geometry of the ram's cavity and the ways in which it could be configured to the shape of the bow timbers. It was demonstrated that close matching between the ram and the bow could be achieved most easily by the direct method using a non-refractory core, but that other methods based on the indirect casting technique using the 'inter model first' sequence could have lead to similar results.

Further insight regarding the ram's construction may come from understanding the origin of the marks found on its inner surface and the process by which they were transferred to the bronze cast. The construction of an inter model by lining the mold with wax (*A_{1-c}*) applied by brushing or by swirling, results in characteristic brush marks or drippings of molten wax, none of which were observed inside the ram.¹⁶⁵ Instead, only straight lines were found in the ram cavity. These marks resemble marks found on other ancient bronzes that are normally associated with the seam lines formed by the clay or wax slabs used during the construction of the model.¹⁶⁶ The use of both clay and wax slabs in the indirect process or the use of wax slabs alone in the direct process would have provided the craftsman better control over the inter model or model than by the use of wax or clay paste.¹⁶⁷ However, this means that seam lines may be left on bronzes whether they were made in the direct casting process or in the indirect casting process. Furthermore, the transformation of seam lines from the model to the final cast (by registering in the core, mold, or both), which may sometimes serve as an indication of a specific sequence, could have occurred in both options *A* and *A₁* and thus, in this case, cannot provide a clue to one particular method. In general, the question of whether or not marks left on the interior or exterior surfaces of a casting model (given that they were not subsequently cleaned off during the final retouching, as most external marks would be) would be partially or fully transferred to the bronze, depends on the subsequent stages of production. Both options *A* and *A₁* involve the introduction of a refractory core material directly to the model or the inter model, a process that automatically transfers any marks left on their inner surface to the core and from there to the bronze. It can be seen that such marks will not be retained if the process involves the use of a preformed core that is formed before (*B*) or without any physical connection to

¹⁶⁵ For discussions and examples of such marks on ancient bronzes see Haynes (1960, 46, pl. 20.1-2; 1992, 35, pl. 2), Stone (1982, 105) and Mattusch (1994, 789, fig. 1).

¹⁶⁶ For examples and discussion of such marks on ancient bronzes see: Haynes 1960, 46, pl. 20.1-2; 1992, 35, pl. 3-4; Mattusch 1994, 789.

¹⁶⁷ Rich (1947, 152) indicates that a model tends to have an uneven wall thickness if it is built free handedly using wax paste applied directly to a mold or core.

the model itself (*e, f*). None of these sequences will leave construction marks in the inter model or model.

Rams and Bows

By examining the possible methods by which the ram's inner cavity could be configured to a given bow shape and by analyzing the origins and preservation of the seam lines inside the ram, it is possible to narrow the range of possible production methods to two: method *A*, a variant of the direct hollow casting process, and method *A_I*, a variant of the indirect hollow casting method. Based on the evidence found on the ram, it is not possible at this point to indicate conclusively which method was used. Although there are practical and technical reasons to support the use of the direct casting method (*A*) as an optimal solution for the construction of the ram, it has been shown that the indirect method could also have been used. In order to provide further insight for this discussion, it is necessary to examine the differences between the direct and the indirect process in a wider perspective, and to evaluate the advantages and disadvantages of each method within the context of the relationship between ram production and ship construction.

Through the use of piece-molding techniques, the indirect method allows, with relative ease, the replication of one model into many identical copies. In contrast, the investment of the original wax model in the direct method and its consequent destruction during the casting process means that the resultant bronze cast will be a unique item representing only one model. Within the practical world of ancient ship construction, however, the mass production and repeatability afforded by the indirect process, and most commonly used in the production of figurative bronzes, may have some major drawbacks when compared with the direct method.¹⁶⁸ The study of ancient ships suggests that hulls were seldom constructed perfectly and that, even if there were official hull building standards at that time, it would be unreasonable to expect the shipwright to

¹⁶⁸ See Haynes (1992, 35) for a list of archaeological bronzes with surface marks that indicate the use of an indirect-casting method.

be able to conform the complex timbers of a ship to an exact model. This in turn means that significant variations in shape between one vessel and another were inevitable, even if built by the same shipwright.¹⁶⁹

Such variations may be evident in the 23 ram sockets preserved at the Octavian war memorial in Actium (30-29 B.C.). Murray indicates that the sockets can be roughly divided into five or six groups of similar sizes, suggesting that each group consisted of rams from the same class of ships ranging from 'fives,' through 'sixes' and 'eights' up to 'tens.'¹⁷⁰ Using the thickness of the wale and ramming timber unit (i.e., ear tip to ear tip distance on the bronze ram) reported by Murray,¹⁷¹ it is possible to group the ram sockets into five size groups that presumably correspond to five different ship classes (table 6).¹⁷² An examination of the ram sockets within each class shows significant variations in geometry both on their interior (as shown by stone blocks intended for the interior) and in their exterior outlines. Assuming that the rams in each size group belong to the same ship class, this comparison suggests that the bows of warships within the same class varied greatly in form. The need to produce rams with a predetermined shape (the indirect casting option) within a reality of inconsistent bow shapes, would have required the bronze worker to make constant adjustments to the inter model, which would have eliminated the main advantages of this process. Alternatively, it may be argued that the bow could be modified to receive a pre-cast ram, an option that could have also been used in the event of reusing old rams on new vessels. The possibility of recycling rams is hinted at by the accounts of the 'Curators of the Shipyards,' a board of ten men that was selected annually to supervise the administration of the Athenian shipyards.

¹⁶⁹ Steffy (pers. comm., 2000) points out that the hull of the fourth-century B.C. Kyrenia ship was asymmetrical due to the inability of its builder to regulate hull shape. For a comparison of the construction methods used for merchant ships and warships, see Steffy (1991, 32; 1994, 61).

¹⁷⁰ Murray and Petsas 1988, 35; Murray 1991b, 73-4, figs. 6.1-4.

¹⁷¹ Murray 1996, 340.

¹⁷² I have used this measurement to group the rams into common classes, as it incorporates three main construction elements (the two wales and the ramming timber) and thus provides the best indication of overall size and geometry using the available data.

Table 6. Actium War Memorial ram sockets grouped according to 'wale – ramming timber unit size' (i.e., distance from ear tip to ear tip). (After Murray 1996, 340; 1991, figs. 6.2-4.)

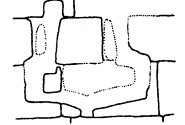
GROUP A					
	Socket # 2	Socket # 4	Socket #	Socket #	Socket #
Wale - ramming timber unit (m)	1.50	1.52			
Starboard wale height; i.e., height of ram's trough (m)	NA	0.48			
Port wale height; i.e., height of ram's trough (m)	0.58	0.53			
Socket outline					

GROUP B					
	Socket # 5	Socket # 9	Socket #	Socket #	Socket #
Wale - ramming timber unit (m)	1.23	1.25			
Starboard wale height; i.e., height of ram's trough (m)	NA	0.40			
Port wale height; i.e., height of ram's trough (m)	0.63	0.37			
Socket outline					

Table 6 Continued

GROUP C					
	Socket # 7	Socket # 8	Socket # C	Socket #	Socket #
Wale - ramming timber unit (m)	1.19	1.19	1.17		
Starboard wale height; i.e., height of ram's trough (m)	NA	0.42	0.40		
Port wale height; i.e., height of ram's trough (m)	0.33	0.37	0.34		
Socket outline					

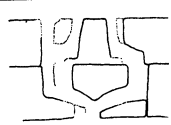
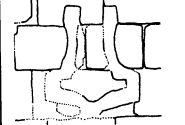
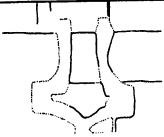
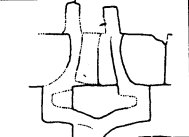
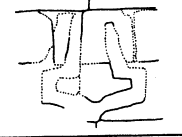

GROUP D					
	Socket # 10	Socket # 11	Socket # 12	Socket # B	Socket #
Wale - ramming timber unit (m)	1.15	1.12	1.10	1.10	
Starboard wale height; i.e., height of ram's trough (m)	0.42	0.42	0.34	0.40	
Port wale height; i.e., height of ram's trough (m)	0.44	0.44	0.33	0.43	
Socket outline					

Table 6 continued

GROUP E					
	Socket # 13	Socket # 14	Socket #15	Socket # A	Socket # D
Wale - ramming timber unit (m)	1.03	1.03	1.00	0.98	1.02
Starboard wale height; i.e., height of ram's trough (m)	0.38	0.35	0.42	NA	0.41
Port wale height; i.e., height of ram's trough (m)	0.36	0.36	0.46	0.38	0.48
Socket outline					

In the fourth century, these ‘Curators of the Shipyards’ were responsible for the yearly distribution and recovery of ships and gear (lines, oars, sails, anchors, rams, etc.) and for recording the names of trierarchs who did not return their gear at the end of the year. They also listed debts owed to the yards, such as ships lost or damaged by trierarches, who were then held responsible for their replacement. Ships damaged beyond repair were dismantled, their rams removed presumably for reassignment to new vessels. The accounts of the board seem to have been inscribed on stone each year as a public record.¹⁷³ *IG II 1629.475-80.* presents the records kept by the Curators of the Shipyards for 325/4: “We took over two rams from the (previous year’s) Curators of the Shipyards, and one from Demonstratus Cytherrius. These were sold in the archonship of Anticles (325/4). And we took back rams: from Conon Anaphlystius, from the *Eucharis*, built by Aleximachus, one; from Thrasyclus Eleusinius, from *Dikaiosyne*, built by Chairion, one; and we handed over, in the shipyards, two rams.”¹⁷⁴ Note that only three of these rams are listed as sold; the other two were retained in the shipyards. Murray suggests that these were serviceable rams that were reused by re-assigning them to new vessels, along with many other rams left in the shipyard.¹⁷⁵ However, the inscription indicates that these two rams came from ships built by two different shipwrights, suggesting that they may have varied greatly in their design and dimensions. Therefore, their ability to fit onto the existing bow of a new ship seems highly unlikely unless the bow could be modified. Considering the structural complexity of a warship’s bow and the difficulties that would arise if it needed to be rebuilt, it can be argued that bow modification was an unlikely possibility. The analysis of the bow remains found within the Athlit ram show a highly intricate construction that combined the main structural elements of the hull, including the keel, the stem, two wales, six side planks and a ramming timber (fig. 26).¹⁷⁶

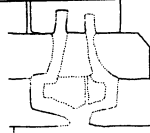
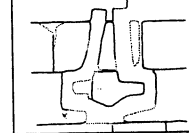
¹⁷³ Murray 1985, 142.

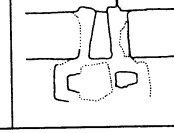
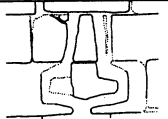
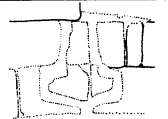
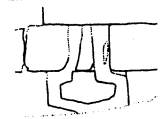
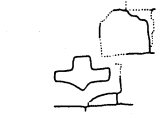
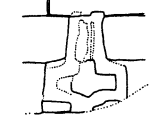
¹⁷⁴ Murray 1985, 146.

¹⁷⁵ Murray 1985, 146, n. 13.

¹⁷⁶ Steffy 1991, 17-32; 1994, 59-61.

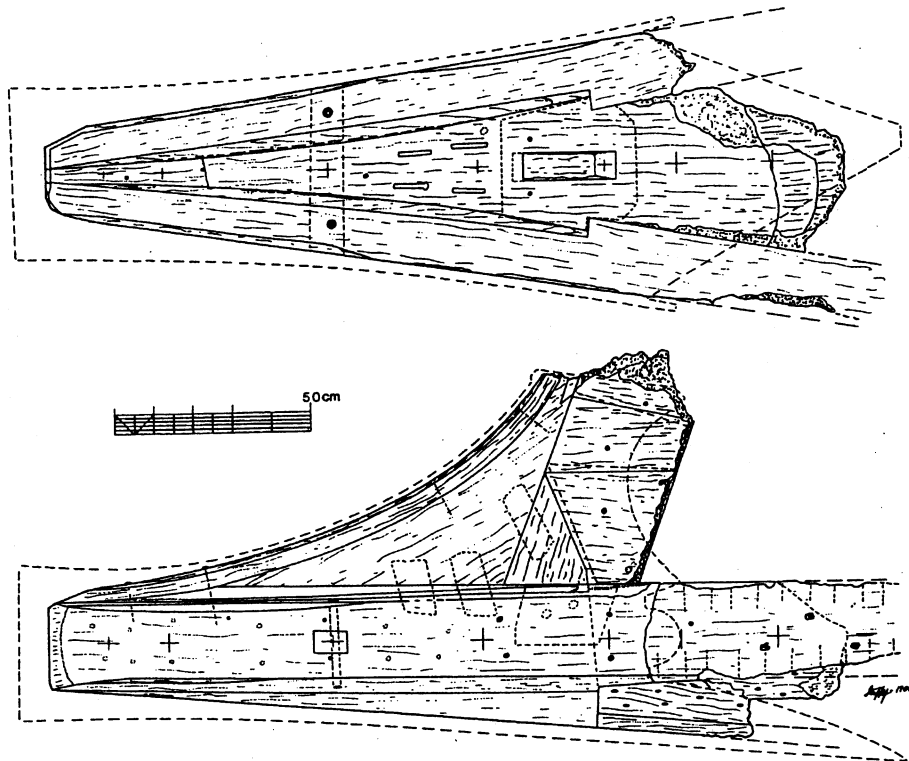

A

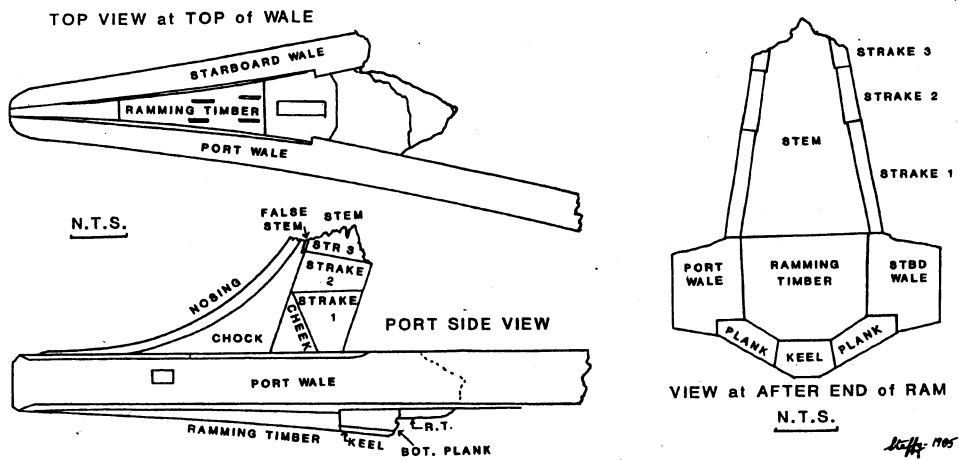

B

Fig. 26. The original timber arrangement within the Athlit ram: *A*, portside view and top view with stem and chock removed; *B*, identification of surviving hull timbers (not to scale). (Steffy 1991, fig. 2.13, 2.15)

Modifying this assemblage beyond a superficial level would have had extensive consequences on the entire hull, and most likely was not the shipwright's first choice of action, particularly if there was a simpler solution available such as that offered by the direct casting process. An alternative explanation of the reuse of old rams may therefore involve a broader interpretation suggesting that it involved melting and recasting the old rams at the shipyards to fit the bows of new ships.

Finally, while at present no bronze foundry remains have been identified in ancient shipyards, the location of many of the excavated casting-pits used to cast large bronze statues, in close proximity to the commission destination, suggests that ram casting may have taken place at the shipyard.¹⁷⁷ This possibility is further supported by the size, weight and design requirements of naval rams that would have most likely necessitated that they be cast near the shipyard.

Additional Evidence for the Use of the Direct Process

Further evidence of the use of the direct process in the production of the Athlit ram may be provided by an examination of the wall thickness of the cast. In general, lining a mold with clay or wax slabs, as in the indirect method, leads to a cast with an even wall thickness in which the inner contours closely follow the external shape.¹⁷⁸ While an even wall thickness can also be achieved in the direct-casting process, through the use of pre-formed wax slabs, this method is likely to result in greater variation in wall thickness, as is clearly observed on the Athlit ram. This is mainly due to the fact that, in order to introduce intricate design and high relief in the direct method, the bronze caster would frequently have to resort to freehand secondary modeling to build up such elements with wax paste on top of the slabs. The walls of a model built in this manner will vary greatly in thickness. Areas of no or little additional modeling will have relatively even wall thickness that corresponds to the initial thickness of the wax slabs,

¹⁷⁷ Craddock 1977, 113. Treister (1996, 218-9) suggests that many of the state-owned metal workshops were constructed in naval dockyards to supply the fittings needed for ship construction and equipment.

¹⁷⁸ Haynes 1968, 104.

whereas areas of additional modeling will exhibit an increase in wall thickness often accompanied by a flat wall surface on the corresponding inner side.¹⁷⁹

Variations in the wall thickness of a model, such as those introduced during secondary modeling in the direct process, tend to complicate the casting process and result in a weakened cast due to uneven cooling and shrinkage rates within the object.¹⁸⁰ It is therefore likely that the bronze caster would have made an effort to even out the thickness of the walls in the model prior to investing, by scooping out excess wax in areas of massive wax buildup. In fact, evidence for the reduction of wall thickness may be found in the ram's fin channels. It appears from the uneven geometry of the channels that they were dug into the solid wax wall behind each fin protrusion after the fins were modeled. Such an operation would be greatly facilitated if the model's interior was made accessible by the withdrawal of the core as in hollow casting by the direct method (option *A*). The digging of the fin channels after laying the wax slabs may also help to explain the obliteration of the main seam line whenever it is intercepted by the channels, as described above (p. 57, fig. 16).

The evidence of the wall thickness and fin channels, combined with the advantages of the direct casting process with a non-refractory core, may further support the use of this method in the production of the ram. However, in order to accept the use of this method, it is necessary to consider its greatest limitation: the shrinkage rates of cast bronze objects. A bronze cast is always smaller than its model due to the combined shrinkage rates of the investment material and the bronze itself (p.11, n.25). Consequently, unless certain measures were taken to oversize the wax model, a ram modeled directly on the bow was likely to be too small to fit it. Oversizing the model throughout could be achieved by coating the bow with a thin layer of clay or even pitch¹⁸¹ on top of which the model could be constructed. Such coating, if used on the Athlit bow, must have been thin enough at the underside of the forward end of the

¹⁷⁹ Mattusch 1994, 789.

¹⁸⁰ Rich 1947, 152; Haynes 1992, 25.

¹⁸¹ Steffy (1991, 32) reports large amounts of pitch applied between the seams and over the ramming timber.

ramming timber to allow the timbers here to be imprinted in the overlaid wax slabs to a greater resolution than anywhere else on the ram. This possibility may also serve to explain the increase in the wall thickness of the bottom plate over this area, as a thinner coating would have left space for a thicker wax wall to be laid over it with no interruption of the exterior surface continuity.

Casting the Ram: Reconstruction

Eisenberg maintained that the ram was cast in a two-part sandbox by a process often referred to as sand-casting.¹⁸² His theory may be summarized as follows:

1. A specially designed pattern of the ram was made in wood (the term 'pattern' is used to describe the model in the sand-casting process).
2. The pattern was positioned horizontally on its side in the drag (the lower section of the sand *flask*, or sand-casting mold, constructed of two iron frames, a drag and a cope) and packed with sand up to the parting line. The cope, or upper section of the flask, was then positioned on the drag and packed with sand.
3. The sand-packed cope was lifted up to release the pattern. At this stage, the area of the symbols was given a special clay coating to improve its surface quality during the casting.
4. A wooden core, supported by wooden sticks coated with clay, was coated with sand and positioned in the mold cavity,. In order to control the wall thickness, the bronze caster also introduced wooden spacers arranged in rows about 12 cm apart.
5. The flask was closed and bronze was introduced into the mold.

It is evident from the description of the ram that the process by which it was cast must have differed from that proposed by Eisenberg. The distribution of casting flaws in a band encircling the aft section-of the ram suggests that it was cast vertically with its head down, and not horizontally as proposed in the sand-casting theory. The highest quality surface of the ram is located in the ramming head, and not around the symbols,

¹⁸² Eisenberg 1991, 44-50., figs. 3.4, 3.6. For descriptions of modern sand-casting processes, see Ammen (1979) and Rich (1947, 141-6).

which are in fact as porous and disfigured as their surroundings and do not show any improved surface quality as suggested by Eisenberg. The low porosity of the ramming head further supports a vertical casting method, in which the pressure of the molten metal squeezes out gas bubbles and leads to an improved casting quality in the lower portion of the mold.¹⁸³ The evenly distributed holes described by Eisenberg as representing the remains of wooden spacers used to position the core in the mold are, in fact, square chaplet holes, some of which still retain remnants of the iron chaplets. Furthermore, the use of a two-part sand mold with a clearly defined parting line would have most likely resulted in a noticeable seam line on the ram's surface; however, no indication of such a mark could be located visually or radiographically on the ram.

In order to accept the sand-casting theory, several problems must be addressed. How would the craftsman have shaped the core to reflect the exact dimensions of the bow and position it evenly in the two-part sandbox? Had a system of wooden spacers was placed inside the mold wouldn't their location be marked by positive dimples of bronze on the final cast? Could the immense core be supported by clay coated wooden sticks, and wouldn't such support system burn out during the casting causing the displacement of the core and destroying the cast? Would the sand-casting technique offer any significant physical advantage that could not be fulfilled by the standard lost-wax technique in common use at this time? Eisenberg singled out the improved porosity of a sand-based mold and its ability to better expel gases from the molten bronze as the primary reasons for its adoption. He indicated that a porous mold would have served to reduce the porosity of the cast, leading to a sounder object. However, a wide range of Medieval and Renaissance technical accounts indicate the common use of clay-based molds in the production of large cast bronzes. For example, clay molds for the production of bells are described by Theophilus during the early 12th century A.D.¹⁸⁴ Clay molds were also used in A.D. 1453 for the casting of a gun of 37 tons to be used in

¹⁸³ For the same reason, in later periods, most bronze and iron cannons were cast vertically with their breech down (p. 5).

¹⁸⁴ Theophilus 1963, 169-70.

the siege of Constantinople.¹⁸⁵ Furthermore, clay is the recommended molding material for bronze cannon production in Biringuccio's detailed account of the manufacturing of guns.¹⁸⁶ Finally, at present, there is no archaeological evidence to indicate that sand-casting was practiced in antiquity. Instead, it is currently accepted that the technique was first introduced sometime in the 14th or 15th centuries.¹⁸⁷

An entirely different approach to the interpretation of the casting of the ram was therefore adopted for the current study, based on the examination of the newly collected technical data in the context of known Classical and Hellenistic bronze foundry practices. Through this work, it was possible to suggest a number of ways by which the Athlit ram might have been cast, with the difficulty being to decide between the various possibilities. It is evident that hollow casting by the direct method with the use of the bow as a temporary non-refractory core offers a logical solution to many of the technical requirements of casting the ram, in particular its need to fit a specific bow shape. If indeed the ram was modeled and cast by this method, the following stages of production can be postulated:

1. The bow was coated with clay or pitch to compensate for the shrinkage of the cast. The coating was evenly applied, with the exception of the underside of the forward end of the ramming timber, where a thinner coating was used.
2. The bow was then covered with wax slabs applied perpendicularly to its central axis, using thicker slabs for the forward section of the bottom plate in order to even out the difference in the coating thickness.
3. The fin protrusions and other external elements were then modeled in wax applied directly onto the wax slabs.
4. The handle devices and pilei were formed in wax by the indirect process using one mold for each pair of symbols. The preformed elements were then attached to the

¹⁸⁵ Maryon 1956b, 363.

¹⁸⁶ Biringuccio 1943, 234-60.

¹⁸⁷ Maryon 1956b, 475.

model. The eagle heads, the kerykeion, and the pilei straps and stars were then modeled freehand.

5. The model was then withdrawn from the bow and the fin channels were hollowed out from the inside.
6. At this point, the model was presumably fitted with an iron armature inserted through the center of the ramming head, resulting in the large patch located here, and placed in a vertical position, head down, in the casting-pit.
7. The cavity of the model was filled with a refractory clay core.
8. Iron chaplets were inserted at regular intervals through the wax walls into the core.
9. The model was then invested in a one-piece mold using a refractory clay mixture and allowed to dry.
10. Once dry, the model was heated slowly to remove the wax and fire the mold.
11. The mold was packed with sand, and bronze was introduced to the space between the mold and the core.
12. After the cast had cooled, the mold and core were removed, and the chaplets were pulled out or trimmed flush to the surface of the object.
13. Chaplet holes, the armature opening and small blow holes were then masked with rectangular patches hammered into pre-cut rectangular beds. Large casting faults were repaired metallurgically by modeling the missing elements in wax, most likely in situ, and then encasing each wax fill with an investment mold. Each mold was then baked and used to apply the repair as a cast-on element.
14. The aft section of the tailpiece was repaired by trimming the area that would receive the large cast-on repair. The latter was most likely modeled in situ in wax, then invested and cast, with additional small cast-on patches applied along the interface in areas where the main repair did not join well.
15. The finished ram was rigged through the lifting lugs and lifted out of the casting-pit.
16. Once transferred to its intended hull and fitted to the bow, it was secured with bolts to the wooden structure and the lifting lugs were broken off.

CHAPTER VII

CONCLUSIONS

The technical analysis of ancient Greek bronze statuary and literary sources suggests that Greek bronze workers had the ability to cast objects exceeding several hundred kilograms as early as the sixth century B.C. In order to overcome some of the complications that arise during the handling and casting of large amounts of molten bronze, large bronzes were often cast in smaller sections that were later assembled to form a complete object. The use of massive bronze castings prevailed in the construction of monumental statuary, the sections of which often weighed in excess of several hundred kilograms. They were also used in the production of utilitarian bronzes, such as weaponry, the physical requirements and function of which could not be met by the standard multi-part construction method. Within the small collection of surviving large-scale ancient bronzes, only the Athlit ram falls into the latter category, the rest without exception being of decorative use. The use of the ram as an impact weapon dictated well-defined physical requirements that could only be fulfilled by a structure cast as a single unit.

The data collected in the current study point to a close connection between the ram and other contemporary bronzes in terms of workmanship and alloy composition. This in turn suggests that it, too, was most likely constructed using the lost-wax casting method. Casting features left on the ram, combined with its overall design, indicate that the bronze workers who made it employed their knowledge and skill of the lost-wax casting method both to reinforce the ram structure and to facilitate its need to fit the predetermined shape of the ship's bow. To fulfill the latter, the ram was most likely modeled in wax directly on the bow and only afterwards invested and cast. To reinforce the strength of the ram in the direction of impact, it was fitted with longitudinal ridges that were integrated into its structure and design. On its underside, these consist of the bottom plate channel that extends through the entire length of ram. Its forward section was cast as a solid bronze bar. The sides of the ram were further strengthened by the

horizontal fins that develop into three longitudinal reinforcements resembling a thunderbolt that extend through the length of the troughs. At the top, the ram was reinforced by the cowl nosing extending along the length of the cowl and merges into the ramming head. These four elements converge at the forward end of the ram, where they are consolidated by the increased wall thickness of the ramming head.

The forward section of the ram was further strengthened by the vertical casting of the ram with its head down. Such a position employed the enormous pressure built up by the mass of metal in the vertical mold to reduce potential casting faults such as high porosity and blow holes in the lower sections of the mold.

The examination of the ram reveals significant asymmetry both in design and iconographic rendering, as well as in structural features such as the deflection of the bottom plate channel to starboard and the variations in the geometry of the trough wale pockets. The reconstruction of the casting method postulates that it was modeled in wax on the bow timbers and then invested and cast, a method that falls under the category of direct casting. This construction process best accounts for the ram's structural asymmetry by suggesting that it reflects the irregularities of the bow timbers, which were replicated in the superimposed wax model. It also supports the high level of variation in design which can be related to the freehand modeling associated with this method. Had the ram been formed after a standard model or form made for a line of ships of specific size, one would expect it to be a more uniform object.

The use of the direct-casting method in constructing the ram is indirectly supported by evidence that indicates that the bows of ancient warships varied greatly from vessel to vessel. Having to construct rams within such constraints required the development of a modeling method that allowed simple adjustment of the inner cavity to the geometry of the bow of a particular ship. This need is best accommodated by the non-industrialized, highly individualized nature of the direct-casting method. To ensure a close match between the ram and the bow timbers, it appears that the technique was further adapted by constructing the model in wax directly on the bow in a sequence termed 'hollow casting by the direct method with a non-refractory core.' At present

there are no parallel studies indicating the contemporary use of this particular variant of the direct casting process elsewhere. However, it is anticipated that further evidence for its use might be gathered through additional analysis of ancient bronzes with specific attention to bronze fittings made for furniture, architectural elements, bow ornaments, and certain weapons, all of which had to be made to fit predetermined structures.

The overall design of the ram and the complex geometry of its ramming head raise some questions as to its function. Had the ram been intended for a head-on collision with an enemy ship, would it not be simpler and more useful to have cast it as a solid block of bronze? Instead, it appears that the bronze caster went to great lengths to increase the strength of the ram while reducing its bulk to the minimum possible. A possible explanation for this might derive from technical considerations related to casting limitations. For example, casting a bronze object with great variations in wall thickness would have introduced structural weakness due to uneven cooling and consequent uneven shrinkage rates. These could be avoided by making the cast even-walled throughout. While this may explain the thin-walled construction of the ram, it does not, however, account for the elaborate fin design. The presence of the fins must have, therefore, had some functional role related to the use of the ram in battle. It is possible that this design allowed the ram to act like a multiple-bladed knife designed to slice the enemy hull longitudinally by splitting its planks along their seams.

The intimate relationship between the Athlit ram and its bow timbers suggests close collaboration between bronze workers and shipwrights. Indeed, only through the combined effort of these two disciplines could a naval ram be successfully constructed and used in battle. The study of surviving rams therefore holds great potential for furthering our understanding of these highly specialized industries in terms of their levels of interaction with one another and their technical abilities. Complete technical analysis of finds such as the Piraeus ram, the Bremerhaven ram, and other known rams will undoubtedly illuminate the methods of their construction and provide a wider perspective for our interpretation of the Athlit ram.

Finally, particular attention should be focused on industrial installations within Classical and Hellenistic shipyards. The potential for identifying ram casting-pits and mold fragments in these locations seems promising and could provide important information regarding the cutting edge of naval warfare technology in the Classical and Hellenistic world.

WORKS CITED

- Ammen, C.W. 1979. *The Complete Handbook of Sand Casting*. Blue Ridge Summit, Pennsylvania: Tab Books.
- Bailey, A.R. 1964. *A Text Book of Metallurgy*. London: Macmillan.
- Basch, L. 1987. *Le musée imaginaire de la marine antique*. Athens, Greece: Institut hellénique pour la préservation de la tradition nautique.
- Bianchi, R.S. 1990. "Egyptian Metal Statuary of the Third Intermediate Period (circa 1070-656 B.C.), from Its Egyptian Antecedents to its Samian Examples." In *Small Bronze Sculpture from the Ancient World*, edited by M. True and J. Podany, 61-84. Malibu, California: J. Paul Getty Museum.
- Biringuccio. 1472. *The Pirotechnia*. Translated by C.S. Smith and M.T. Gnudi. New York: American Institute of Mining and Metallurgical Engineers.
- Botta, P.E., and E. Flandin. 1972. *Monument de Ninive*. Osnabrück, Germany: Biblio Verlag.
- Breitman, B., M. Doron, E. Yellin, H. Feldman, and N. Yoram. 1991. "Radiographic Examination of the Athlit Ram." In *The Athlit Ram*, edited by L. Casson and J.R. Steffy, 83-6. College Station: Texas A&M University Press.
- Brouskari, M.S. 1985. *The Paul and Alexandra Canellopoulos Museum: A Guide*. Athens, Greece: M.S. Brouskari.
- Calligas, P. 1996. "Bronze Ram of a Ship." In *Tropis 4: 4th International Symposium on Ship Construction in Antiquity*, edited by H. Tzalas, 129-41. Athens, Greece: Hellenic Institute for the Preservation of Nautical Tradition.
- Casson, L. 1971. *Ships and Seamanship in the Ancient World*. Princeton, New Jersey: Princeton University Press.

- Casson, L., and E. Linder. 1991. "The Evolution in Shape of the Ancient Ram." In *The Athlit Ram*, edited by L. Casson and J.R. Steffy, 67-71. College Station: Texas A&M University Press.
- Cavanagh, P.K. 1990. "Practical Considerations and Problems of Bronze Casting." In *Small Bronze Sculpture from the Ancient World*, edited by M. True and J. Podany, 145-60. Malibu, California: J. Paul Getty Museum.
- Cellini. 1967. *Treatises on Goldsmithing and Sculpture*. Translated by C.R. Ashbee. New York: Dover Publications.
- "Cover Story." 1982. United States *National Sculpture Review* 31(2):3.
- Craddock, P.T. 1976. "The Composition of the Copper Alloys Used by the Greek, Etruscan and Roman Civilizations, 1. The Greeks Before the Archaic Period." *JAS* 3:93-113.
- Craddock, P.T. 1977. "The Composition of the Copper Alloys Used by the Greek, Etruscan and Roman Civilizations, 2. The Archaic, Classical and Hellenistic Greeks." *JAS* 4:103-23.
- Craddock, P.T. 1978. "The Composition of the Copper Alloys Used by the Greek, Etruscan and Roman Civilizations, 3. The Origins of Brass." *JAS* 5:1-16.
- Craddock, P.T. 1982. "Gold in Antique Copper Alloys." *Gold Bulletin* 2:69-72.
- Craddock, P.T. 1985. "Three Thousand Years of Copper Alloys: From the Bronze Age to the Industrial Revolution." In *Application of Science in Examination of Works of Art*, edited by P.A. England and L. Van Zelst, 59-67. Boston: Museum of Fine Arts.
- Dalley, S. 1988. "Neo-Assyrian Evidence for Bronzeworking Centers." In *Bronzeworking Centers of Western Asia c.1000 – 539 B.C.*, edited by J. Curtis, 97-110. London: Kegan Paul International.
- Desch, C.H. 1927. "The Tempering of Copper." *Discovery* 8:361-2.

- Edgar, M.C.C. 1903. *Greek Molds: Catalogue général des antiquités égyptiennes du Musée du Caire*. 2nd ed. Osnabrück, Germany: Otto Zeller Verlag.
- Eisenberg, S. 1991. "Metallurgical Analysis of the Ram." In *The Athlit Ram*, edited by L. Casson and J.R. Steffy, 40-50. College Station: Texas A&M University Press.
- Formigli, E. 1984. "La tecnica di costruzione delle statue di Riace." *Due Bronzi. Bda* (3 ser. spec.), 1:107-42.
- Fransworth, M., C.S. Smith, and J.L. Rodda. 1949. "Metallographic Examination of a Sample of Metallic Zinc from Ancient Athens." *Hesperia Supplement* 8:126-9.
- Gabriel, A. 1932. "La construction, l'attitude et l'emplacement du colosse de Rhodes." *BCH* 56:331-59.
- Galeria Nefer Ancient Art. 1987. "Nefer." (sales catalogue) 5:25. Zurich, Switzerland.
- Harrison, E.B. 1977. "Alkmenes' Sculpture for the Hephaisteion: Part I, The Cult Statues." *AJA* 81:137-78.
- Haynes, D. 1957. "Philo of Byzantium and the Colossus of Rhodes." *JHS* 77:311-2.
- Haynes, D. 1960. "Appendix" to "The Bronze Priests and Priestesses from Nemi," by S. Haynes. *RM* 67:45-7.
- Haynes, D. 1968. "The Technique of the Chatsworth Head." *RA* 1:101-12.
- Haynes, D. 1981. "The Technique of the Erbach Griffin-Protomai." *JHS* 101:136-8.
- Haynes, D. 1992. *The Technique of Greek Bronze Statuary*. Mainz, Germany: Verlag Philipp Von Zabern.
- Hesiod. 1998. *Homeric Hymns*. Loeb Classical Library.

- Higgins, R. 1988. "The Colossus of Rhodes." In *The Seven Wonders of the Ancient World*, edited by P.A. Clayton and M.J. Price, 124-37. London: Routledge.
- Hook, D.R. 1998. "Inductively-Coupled Plasma Atomic Emission Spectrometry and Its Role in Numismatic Studies." In *Metallurgy in Numismatics*, vol. 4, edited by W.A. Oddy and M. R. Cowell, 237-52. London: Royal Numismatic Society.
- Hughes, M.J., M.R. Cowell, and P.T. Craddock. 1976. "Atomic Absorption Techniques in Archaeology." *Archaeometry* 18:19-37.
- Jacobson, D.M., and M.P. Weitzman. 1992. "What Was Corinthian Bronze?" *AJA* 96:237-47.
- Kantzia, C., and G. Zimmer. 1989. "Rhodische kolosse." *AA* 4:497-523.
- Konstantinos, Z. 2001. "Excavations at the Actian Tropaeum at Nikopolis, A Preliminary Report." In *Foundation and Destruction, Nikopolis and Northwestern Greece: The Archaeological Evidence for the City Destructions, the Foundation of Nikopolis and the Synoecism*, edited by J. Isager, 29-41. Athens, Greece: Danish Institute at Athens.
- Kyrieleis, H. 1990. "Samos and Some Aspects of Archaic Greek Bronze Casting." In *Small Bronze Sculpture from the Ancient World*, edited by M. True and J. Podany, 15-30. Malibu, California: J. Paul Getty Museum.
- Langdon, S. 1912. *Die neubabylonischen Königsinschriften*. Leipzig, Germany: J.C. Hinrichs.
- Lechtman, H., and H. Steinberg. 1970. "Bronze Joining: A Study in Ancient Technology." In *Art and Technology: A Symposium on Classical Bronzes*, edited by S. Doeringer, D.G. Mitten, and A. Steinberg, 5-36. Cambridge, Massachusetts: MIT Press.
- Lie, A.G. 1929. *The Inscriptions of Sargon II King of Assyria: The Annals*. Paris: Librairie Orientaliste Paul Geuthner.
- Linder, E. 1991. "The Discovery." In *The Athlit Ram*, edited by L. Casson and J.R. Steffy, 1-5. College Station: Texas A&M University Press.

- Lombardi, G. 1998. "From the Shell to its Content: the Casting Cores of the Two Bronze Statues from Riace." *JAS* 25:1055-66.
- Lucas, A., and J.R. Harris. 1962. *Ancient Egyptian Materials and Industries*. London: Edward Arnold.
- Maryon, H., 1949. "Metal Working in the Ancient World." *AJA* 53:93-125.
- Maryon, H. 1956a. "The Colossus of Rhodes." *JHS* 76:68-86.
- Maryon, H. 1956b. "Fine Metal Work." In *A History of Technology*, vol. 2, edited by C. Singer, E.J. Holmyard, A.R. Hall, and T.I. Williams, 449-92. New York: Oxford University Press.
- Maryon, H., and H.J. Plenderleith. 1954. "Fine Metal Work." In *A History of Technology*, vol. 1, edited by C. Singer, E.J. Holmyard, and A.R. Hall, 623-83. New York: Oxford University Press.
- Mattusch, C.C. 1977. "Bronze and Ironworking in the Athenian Agora." *Hesperia* 46:340-79.
- Mattusch, C.C. 1988. *Greek Bronze Statuary*. London: Cornell University Press.
- Mattusch, C.C. 1990. "The Casting of Greek Bronzes: Variation and Repetition." In *Small Bronze Sculpture from the Ancient World*, edited by M. True and J. Podany, 125-44. Malibu, California: J. Paul Getty Museum.
- Mattusch, C.C. 1991. "Corinthian Metalworking: The Gymnasium Bronze Foundry." *Hesperia* 3:383-95.
- Mattusch, C.C. 1994. "The Production of Bronze Statuary in the Greek World." In *Das Wrack, Der antike Schiffsfund von Mahdia*, vol. 2, edited by G.H. Salies, H.H. von Prittwitz und Gaffron, and G. Bauchhenss, 789-800. Cologne, Germany: Rheinland-Verlag GmbH.
- Mills, J.W., and M. Gillespie. 1969. *Studio Bronze Casting-Lost Wax Method*. New York: Frederick A. Praeger.

- Moorey, P.R.S. 1982. "The Archaeological Evidence for Metallurgy and Related Technologies in Mesopotamia." *Iraq* 44:13-38.
- Moorey, P.R.S. 1985. *Materials and Manufacture in Ancient Mesopotamia: The Evidence of Archaeology and Art, Metals and Metalwork, Glazed Materials and Glass. BAR-IS 237*. Oxford: BAR International Series.
- Murray, W.M. 1985. "The Weight of Trireme Rams and the Price of Bronze in Fourth-Century Athens." *GRBS* 26:141-50.
- Murray, W.M. 1991a. "Classification of the Athlit Ship: A Preliminary Report." In *The Athlit Ram*, edited by L. Casson and J.R. Steffy, 72-5. College Station: Texas A&M University Press.
- Murray, W.M. 1991b. "The Provenience and Date: The Evidence of the Symbols." In *The Athlit Ram*, edited by L. Casson and J.R. Steffy, 52-66. College Station: Texas A&M University Press.
- Murray, W.M. 1996. "Polyremes from the Battle of Actium: Some Construction Details." In *Tropis 4: 4th International Symposium on Ship Construction in Antiquity*, edited by H. Tzalas, 335-50. Athens, Greece: Hellenic Institute for the Preservation of Nautical Tradition.
- Murray, W.M., and P.M. Petsas. 1988. "The Spoils of Actium." *Archaeology* 41:28-35.
- Nicolaou, K. 1972. "Archaeological News from Cyprus, 1970." *AJA* 76:311-20.
- North, N.A., and I.D. MacLeod. 1987. "Corrosion of Metals." In *Conservation of Marine Archaeological Objects*, edited by C. Pearson. London: Butterworths.
- Oates, J. 1979. *Babylon*. London: Thames and Hudson.
- Oliver-Smith, P. 1975. "The Houston Bronze Spearbearer." *AntP* 15:95-109.
- Parrot, A. 1961. *Sumer*. New York: Golden Press.

- Pausanias. 1993. *Description of Greece*. Loeb Classical Library.
- Pliny the Elder. 1984. *Natural History*. Loeb Classical Library.
- Ponting, M.J. 1999. "East Meets West in Post-Classical Bet She'an: The Archaeometallurgy of Culture Change." *JAS* 26:1311-21.
- Porada, E. 1965. *Art of Ancient Iran*. London: Greystone Press.
- Pridemore, M.G. 1996. "The Form, Function, and Interrelationships of Naval Rams: A Study of Naval Rams from Antiquity." Unpublished M.A. thesis, Texas A&M University.
- Rich, J.C. 1947. *The Materials and Methods of Sculpture*. New York: Oxford University Press.
- Ridgway, B.S. 1977. "The Palatian Tripod and the Serpentine Column." *AJA* 81:374-9.
- Ridgway, B.S. 1987. "The Sculpture." In *The Porticello Shipwreck*, edited by C.J. Eiseman and B.S. Ridgway, 63-106. College Station: Texas A&M University Press.
- Rolley, C. 1983. "Bronzes grecs et orientaux: Influences et apprentissages," *BCH* 107:111-32
- Rolley, C. 1986. *Greek Bronzes*. London: Sotheby's Publications.
- Romano, I. 1980. *Early Greek Cult Images*. Unpublished Ph.D. diss., University of Pennsylvania.
- Sano, Y., and T. Tominaga. 1982. "Segregations of Elements in Ancient Chinese Coinage." *Japan Japanese Antiques and Art Crafts* 27:12-7.
- Schneider, G. 1989. "Bronze Casting at Olympia in Classical Times." *MASCAJ* 6:17-24.

- Scott, D.A., and J. Podany. 1990. "Ancient Copper Alloys: Some Metallurgical and Technological Studies of Greek and Roman Bronzes." In *Small Bronze Sculpture from the Ancient World*, edited by M. True and J. Podany, 31-60. Malibu, California: J. Paul Getty Museum.
- Shear, T.L. 1937. "The American Excavations in the Athenian Agora: The Campaign of 1936." *Hesperia* 6:333-81.
- Smith, C.S. 1967. "The Interpretation of Microstructures of Metallic Artifacts." In *Application of Science in Examination of Works of Art*, 20-52. Boston: Museum of Fine Arts.
- Snodgrass, A.M. 1971. *The Dark Ages of Greece*. Edinburgh, Scotland: Edinburgh University Press.
- Sobottka-Braund, U., and F. Willer. 1994. "Experimente zur antiken Guss- und Löttechnik." In *Das Wrack, Der antike Schiffsfund von Mahdia*, vol. 2, edited by G.H. Salies, H.H. von Prittwitz und Gaffron, and G. Bauchhenss, 1017-21. Cologne, Germany: Rheinland-Verlag GmbH.
- Steffy, J.R. 1991. "The Ram and Bow Timbers: A Structural Interpretation." In *The Athlit Ram*, edited by L. Casson and J.R. Steffy, 6-39. College Station: Texas A&M University Press.
- Steffy, J.R. 1994. *Wooden Ship Building and the Interpretation of Shipwrecks*. College Station: Texas A&M University Press.
- Steinberg, A. 1973. "Joining Methods on Large Bronze Statues: Some Experiments in Ancient Technology." In *Application of Science in Examination of Works of Art*, edited by W.J. Young, 103-38. Boston: Museum of Fine Arts.
- Steinberg, A. 1981. "Analyses of Selected Gordion Bronzes." In *The Gordion Excavations Final Reports*. Vol. 1, *Three Great Early Tumuli*, edited by E.L. Kohler, 286-9. Philadelphia: University Museum, University of Pennsylvania.
- Stainchaouer, G. 1998. *Ta mnemeia kai to Archaiologiko Mouseio tou Peiraias*. Athens, Greece: kdoseis M. Toumpes.

- Stone, R.E. 1982. "Antico and the Development of Bronze Casting in Italy at the End of the Quattrocento." *MMAJ* 16:87-113.
- Strabo. 2000. *The Geography*. Loeb Classical Library.
- Theophanes of Byzantium. *Chronicle*. Translated by H. Turtledove. Philadelphia: University of Pennsylvania Press. 1982.
- Theophilus. 1963. *On Diverse Arts*. Translated by J.G. Hawthorne and C.S. Smith. Chicago: Chicago University Press.
- Thompson, H.A. 1948. "The Excavation at the Athenian Agora Twelfth Season: 1947." *Hesperia* 17:149-96.
- Thureau-Dangin, F. 1912. *Une relation de la huitième campagne de Sargon*. Paris: Librairie Paul Geuthner.
- Torr, C. 1964. *Ancient Ships*. 2nd ed. Chicago: Argonaut.
- Treister, M.Y. 1996. *The Role of Metals in Ancient Greek History*. Leiden: E.J. Brill.
- Tylecote, R.F. 1979. *A History of Metallurgy*. London: Metals Society.
- van Doorninck, F.H. 1982. "Protogeometric Longships and the Introduction of the Ram." *IJNA* 11:277-85.
- van Lokeren, S. 2000. "Experimental Reconstruction of the Casting of Copper 'Oxhide' Ingots." *Antiquity* 74:275-6.
- Willer, F. 1994. "Zur herstellungstechnik der Herme." In *Das Wrack, Der antike Schiffsfund von Mahdia*, vol. 2, edited by G.H. Salies, H.H. von Prittwitz und Gaffron, and G. Bauchhenss, 959-70. Cologne, Germany: Rheinland-Verlag GmbH.
- Young, R.S. 1981. *The Gordion Excavations Final Reports*. Vol.1, *Three Great Early Tumuli*, edited by E.L. Kohler. Philadelphia: University Museum, University of Pennsylvania.

APPENDIX A

CHEMICAL ANALYSIS OF THE ATHLIT RAM

The chemical investigation of large-scale Classical and Hellenistic bronzes focuses primarily on the formulas used to produce copper alloys and how these changed over time. The main goal of the chemical analysis of the Athlit ram was to characterize the components of its alloy to allow comparison with other Classical and Hellenistic bronzes. In addition, it was hoped that the analysis could clarify certain technical problems, such as the nature of the repaired sections and the relationship between the main cast of the ram and its decorations.

Sampling and Analytical Procedures

The analysis was conducted using inductively-coupled plasma atomic emission spectrometry (ICP-AES) with a Perkin Elmer Plasma 400 instrument at the School of Chemical, Environmental and Mining Engineering at the University of Nottingham, U.K.¹⁸⁸ The calibration of the instrument was accomplished using synthetic multi-element standards matched for total dissolved salt and acid content.¹⁸⁹ This type of analysis requires the removal of a small metal sample, which is dissolved, prior to analysis, in concentrated acid and diluted, prior to analysis, up to a standard volume (typically 25 ml) to ensure a broadly standard dilution factor.¹⁹⁰ The sample was collected by drilling a small hole (0.1 cm) in an inconspicuous area of the ram and collecting the drillings, after discarding the first millimeter or so in order to avoid contamination of the sample with unrepresentative material and corrosion products (the low totals in table 7 are probably due to such unavoidable contamination). A total of ten

¹⁸⁸ The chemical analysis of the ram was performed by Dr. Matthew J. Ponting of the Department of Archaeology, University of Nottingham, U.K. I would like to thank Dr. Ponting for undertaking the analysis, as well as for his help in the sampling and interpretation of the results.

¹⁸⁹ Hook 1998.

¹⁹⁰ The dissolution method used here was essentially that developed at the British Museum: Hughes, Cowell and Craddock 1976.

samples weighing approximately 25 mg each were collected from selected parts of the ram for chemical analysis (fig. 27).¹⁹¹

In most analyses of ancient metalwork, it is usual to run standard alloys of known composition alongside the study samples in order to assess the precision (or reproducibility) and accuracy (i.e. how close an analysis is to the true composition) of the procedure. Two runs of certified standard reference material (183/3 standard gunmetal) at the beginning and end of the analysis were used. They indicated an instrumental precision of <3% for all elements above detection limits, with figures worsening as the detection limit was approached. The actual precision of the analysis (reproducibility of a given analysis by element) is approximately 1–2% for major elements (>1%), 5–10% for minor elements (0.05–1%) and 10–20% for trace elements (<0.05%). Accuracy, as determined by the certified reference material, is 1–5% for major and minor elements, and about 10% for trace elements, with this figure again worsening as the detection limit for the particular element in question is approached.

Results and Discussion

The results of the analysis are presented in table 7. Samples 2, 4, 5 and 9 are especially close in terms of their composition and, because of their locations, can be reliably regarded as representative of the metal composing the main casting of the ram. An average value calculated from these data was used as a 'base' composition for the ram (table 8). It indicates a major element distribution with mean values of 90.4% copper and 9.78% tin, with virtually no lead. This composition, when compared with the available analytical data for Classical and Hellenistic bronze statuary (table 1), places the ram well within the range of Classical and Hellenistic alloy types.

The distribution of trace elements (i.e., small amounts of other metallic elements which are geochemically related to the parent metal used in the casting) in the samples from the Athlit ram permits some discussion regarding its fabrication history. When the

¹⁹¹ The drill holes were left unplugged to facilitate the identification of the sample locations and to prevent confusion in future studies. The small size of the drill holes is considered unobtrusive.

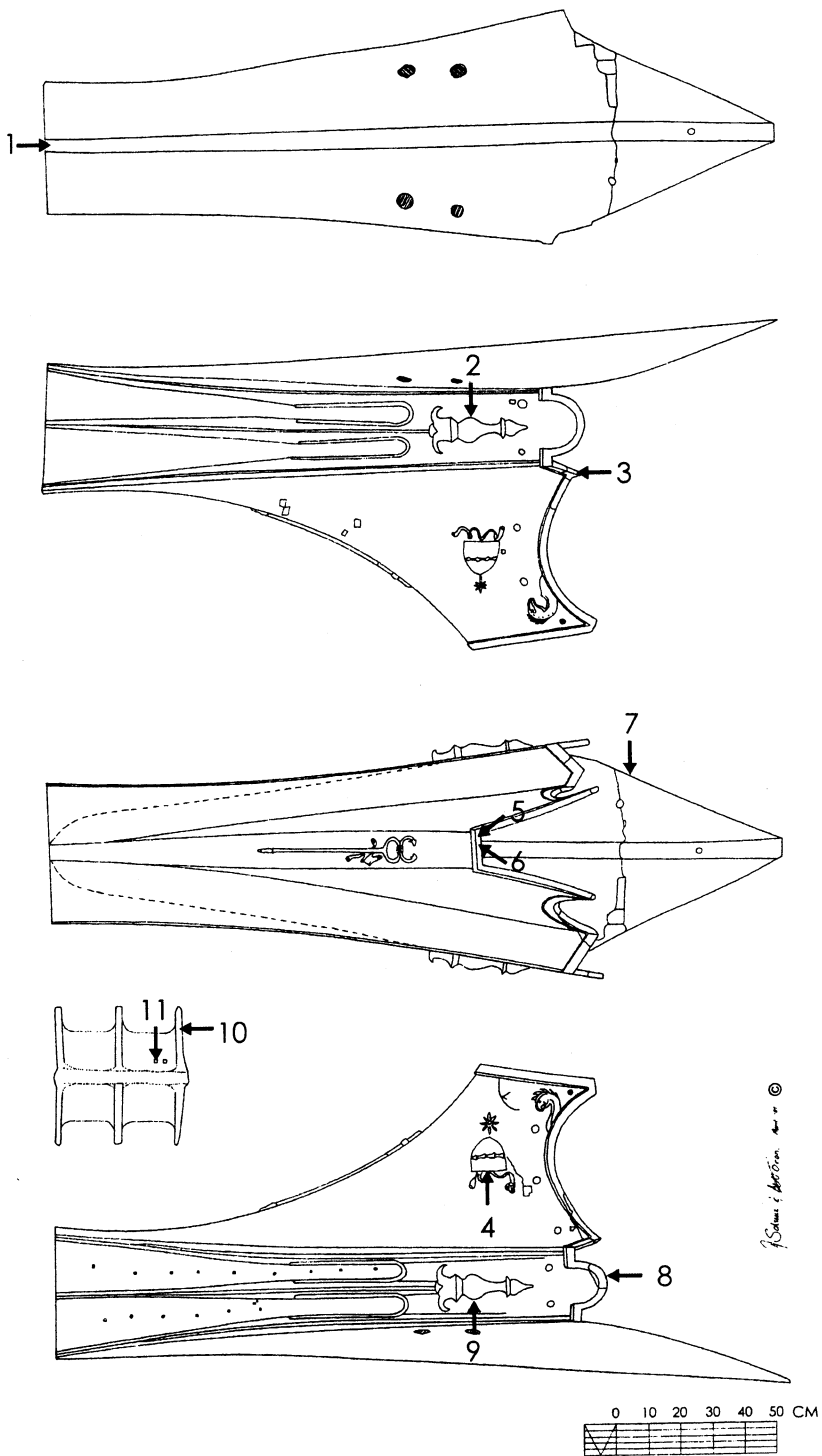

Fig. 27. Sampling site locations for ICP-AES analysis.

Table 7. Chemical composition of metal samples from the Athlit ram.

Sample No.	Site of Sample	Element (weight percent)													Total
		Cu	Sn	Pb	As	Zn	An	Co	Ni	Fe	Ag	Au	Mn		
1	Bottom plate channel under the ram's head	90.8	7.14	<0.1	0.148	0.01	<0.05	0.082	0.030	0.059	0.009	<0.011	<0.001	98.3	
2	Starboard trident handle, Main section underside	90.5	9.46	<0.1	0.212	0.02	0.016	0.068	0.032	0.041	0.013	<0.011	0.001	100.4	
3	Cast on repair on the right side of starboard trough aft-end ceiling	90.8	9.64	0.12	0.184	0.02	0.016	0.072	0.040	0.100	0.013	<0.011	<0.001	101.0	
4	Port side helmet underside	90.1	9.89	<0.1	0.177	0.01	0.016	0.055	0.031	0.018	0.010	<0.011	<0.001	100.3	
5	Inner side of the section connecting the two cowl flanges	90.2	9.03	<0.1	0.185	0.01	0.011	0.058	0.032	0.017	0.011	<0.011	<0.001	99.6	
6	*														
7	Cast on tail piece repair, starboard edge aft of the join	90.1	10.32	<0.1	0.173	0.04	0.023	0.140	0.029	0.046	0.030	<0.011	<0.001	100.9	
8	cast on repair on the port trough ear	87.1	11.11	0.14	0.180	0.11	0.021	0.072	0.040	0.082	0.015	<0.011	<0.001	98.8	
9	Port trident handle, main section underside	90.6	10.73	<0.1	0.190	0.10	0.013	0.067	0.031	0.050	0.012	<0.011	0.001	101.8	
10	Starboard forward edge of the top fin**	89.7	12.00	<0.1	0.218	0.15	0.022	0.083	0.034	0.121	0.014	<0.011	<0.001	102.4	
11	Repair patch on the ramming head, second from the top between the upper and middle starboard fins	94.3	9.31	<0.1	0.169	0.13	0.019	0.089	0.036	0.041	0.010	<0.011	<0.001	104.1	

* Sample no. 6 was extracted 1 centimeter to port of sample five for Lead Isotope analysis

** Sample no. 10 may have been contaminated as a result of the drill hitting a blow hole in the cast rich in powder-like black substance, most of which was discarded but some may have entered the sample.

individual values for each trace element in each sample are subtracted from this norm and plotted, it becomes evident that the variance from the norm is very small – less than $\pm 0.025\%$ - except in one sample, in which the amount of zinc is greater than the norm by 0.06% (fig. 28).

When the same calculation is made for the other samples, taken from repaired areas and patches (table 9, fig. 29), a different picture emerges. In these samples, the variances from the norm are often considerably greater for certain elements, and therefore suggest that these repairs were made using metal originating from a different alloy batch. A comparison of the composition of a hammered repair patch (sample 11) to the norm for the main body of the ram shows a close correlation in trace element levels and suggests that the metal used for this patch was of the same batch used for the primary casting. However, samples 3 and 8, taken from the two small cast repairs, differ from the norm in their trace element composition. They are also notable as the only samples containing a significant, though still very low, lead content (0.12% and 0.14% , respectively). The similar composition of the two samples suggests that they were made from the same batch of metal, which itself differed from that used for the main ram casting.

The most divergent sample was that taken from the repaired tailpiece (sample 7). This sample contains significantly higher levels of cobalt (0.140%), silver (0.030%) and antimony (0.023%). The lead content of this section is below detectable limits ($<0.1\%$); however, its tin level is above the norm (10.32%). These variations again indicate the use of an altogether distinct metal batch for the repair of the tail-piece. The higher tin levels may have been useful in lowering the melting point of the alloy and thus assisting in the repair process.¹⁹² An increased tin level (12%) was also observed in

¹⁹² Rolley (1983, 119) describes two instances where cast-on repairs to eighth-century B.C. Greek tripods had tin levels 0.14% and 0.44% higher than that of the repaired object.

Table 9. Chemical composition of metal samples removed from repaired areas.

Sample No.	Site of Sample	Element (weight percent)													Total			
		Cu	Sn	Pb	As	Zn	An	Co	Ni	Fe	Ag	Au	Mn					
	Mechanical Repairs																	
11	Repair patch on the ramming head, second from the top between the upper and middle starboard fins	94.3	9.31	<0.1	0.169	0.13	0.019	0.089	0.036	0.041	0.010	<0.011	<0.001					104.1
	Metallurgical Repairs																	
3	Cast on repair on the right side of starboard trough aft-end ceiling	90.8	9.64	0.12	0.184	0.02	0.016	0.072	0.040	0.100	0.013	<0.011	<0.001					101.0
8	Cast on repair on the port trough ear	87.1	11.11	0.14	0.180	0.11	0.021	0.072	0.040	0.082	0.015	<0.011	<0.001					98.8
7	Cast on repaired tail piece starboard edge aft of the join	90.1	10.32	<0.1	0.173	0.04	0.023	0.140	0.029	0.046	0.030	<0.011	<0.001					100.9
	'Base' composition of the ram according to the mean values of samples 2,4,5,9	90.4	9.78	0.02	0.191	0.03	0.014	0.062	0.031	0.032	0.012	<0.011	0.000					100.5
	Standard deviation	0.21	0.73	0.01	0.015	0.04	0.002	0.007	0.001	0.017	0.001							

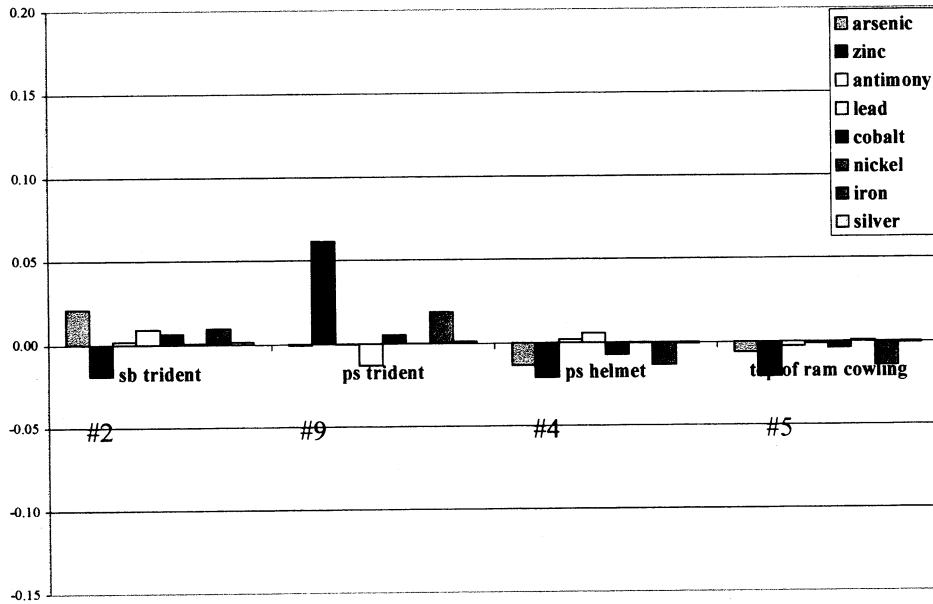

Fig. 28. Difference of individual bulk samples (i.e., samples from the ram main casting) from the ram 'norm'.

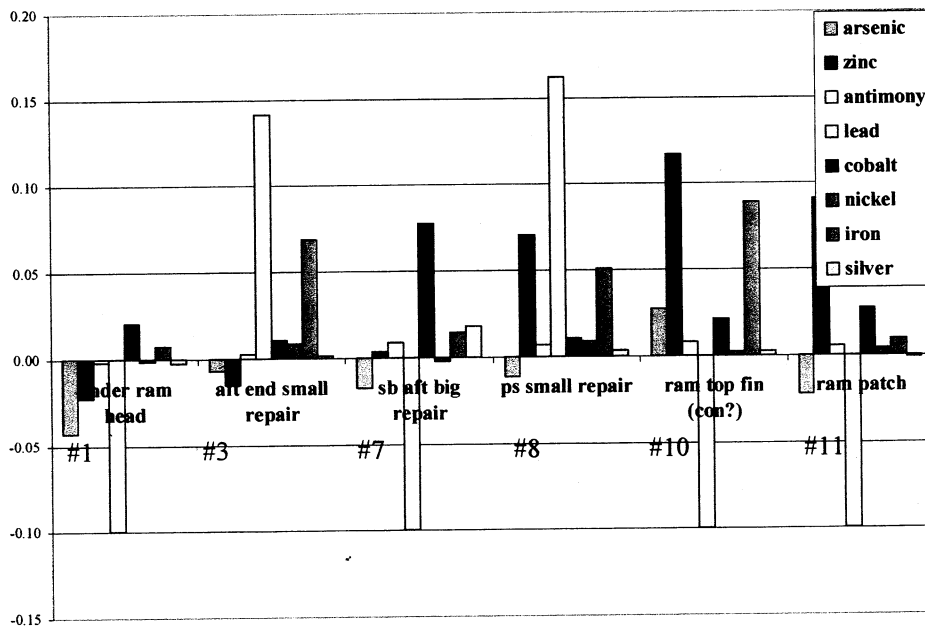

Fig. 29. Difference of repairs and unusual samples from the ram 'norm'.

a sample taken from the fin (sample 10), which also showed a high iron content (0.121%). It is possible that the increased iron level results from contamination caused by drilling through a blow hole that may have contained iron corrosion introduced by external leaching.¹⁹³ The high tin level, however, raises some questions regarding this area of the ram. The radiographic analysis of the fin indicates exceptionally low porosity levels when compared to other areas of the ram. Since the fins were the 'cutting edges' of the ram, it is tempting to relate the higher tin level and the low porosity in this area to an intentional effort to improve their mechanical properties. This could be achieved either by cold working (an action that would have also lead to compression of the metal and reduced porosity) or by adding tin to the molten metal during the pour of this section.¹⁹⁴ The marked effect of an increased tin level on cold working of copper-tin alloys is demonstrated by comparing the hardness of two alloys with differing levels of tin. The initial hardness (Brinell scale), as cast, of 9.31% tin bronze is 136, while that of 10.34% tin bronze is 171. After hammering, the hardness of these alloys increases to 257 and 275, respectively.¹⁹⁵ However, the use of any of these techniques can only be confirmed through additional analysis and metallographic examination of cross sections, neither of which could be accomplished during the time available for this study. Based on available evidence, it appears that these compositional variations may be related to alloy segregation at the cast extremities, a characteristic occurrence in large casts that can lead to variations in alloy composition throughout an object.¹⁹⁶ This may also help to explain the unusual composition of sample 1, taken from the ram's head, which exhibits significantly lower levels of tin (7.14%) and antimony (<0.05%).

¹⁹³ See Ponting (1999, 1318) for an example of high iron levels in Abasid and Late Byzantine bronzes from Bet She'an, Israel, which may have originated from iron corrosion products.

¹⁹⁴ The analysis of the Riace bronzes indicated variations in tin levels throughout main section (legs and torso) with higher tin levels at this section upper parts. Mattusch (1988, 206, table 1, n. 94) suggested that these variations may have resulted from the addition of tin to the molten metal during the pour to improve fluidity at certain stages of the cast.

¹⁹⁵ Desch 1927.

¹⁹⁶ Bailey 1964, 389-90; Sano and Tominaga 1982.

APPENDIX B

RADIOGRAPHY

Shortly after its discovery, the Athlit ram underwent radiographic analysis with the primary objective of studying the arrangement of timbers and fastenings encased within the cavity in order to facilitate their removal and conservation.¹⁹⁷ Since these images were taken through the entire width of the ram, they often exhibited poor resolution in areas such as the cast walls. In addition, they combined two opposite walls into a single radiograph image, complicating the interpretation of details. Once the timbers were removed from the ram's internal cavity, it became possible for the first time to compile a complete radiographic record of the ram. Consequently, during the current study it was possible to systematically radiograph the entire ram in order to create mosaic images representing most of its surface (appendix E).

Due to the size and weight of the object, it was not possible to transport it to a radiographic facility. Instead, the radiography campaign was carried out at the National Maritime Museum in Haifa, where the ram is currently on display. The radiographic work was performed by Gabi Shoef, Ltd., a commercial company specializing in non-destructive testing and quality control.¹⁹⁸ The following section will describe the working procedure with the intention of providing information that may be of interest to others researching large bronze objects. The actual interpretation of the radiographs is incorporated into previous chapters in order to complement other aspects of the research.

¹⁹⁷ Preliminary attempts to radiograph the ram with a portable industrial X-ray unit were made soon after its recovery. These were unsuccessful due to the low energy level of the X-ray unit combined with the double thickness of the bronze walls and more than 20 cm of intact waterlogged wood preserved in the interior cavity. Consequently, the ram was transferred to the Nondestructive Testing Department of Soreq Nuclear Research Center in Yavne, Israel, where it was radiographed using gamma radiation emitted from a cobalt-60 source in a set of one hour exposures (Breitman et al. 1991, 83).

¹⁹⁸ Gabi Shoef, Ltd., 5 Eliahu Shamir St., Mishmar Hashiva, Israel. Tel. 03-9605559, Fax. 03 9604160, E-mail: shoef@netvision.net.il.

Procedures

Sources

Two portable isotope sources were used during the radiography campaign: Selenium (Se^{75}) with an activity of 19 curies and Iridium (Ir^{192}) with an activity of 28 curies. The dose rate of Selenium-75 with an activity of 19 curies, using a conversion factor of 0.2 Roentgen/hour-curie at a distance of 1 m, is 3.8 R/h. The dose rate of Iridium-192 with an activity of 28 curies, using a conversion factor of 0.44 Roentgen/Hour-Curie at a distance of 1 m, is 12.32 R/h.

The sources were contained in special projectors designed to reduce the radiation levels during handling. The projectors weighed 7.0 kg and 12.5 kg respectively. The sources were operated using a 14 m control cable. Once opened, the radiation was transferred from the source to the exposure point with a short cable rigged at its end with a collimator to facilitate directional radiation and to reduce peripheral exposure within the gallery. The exposure distance, also called Focus Film Distance (FFD), used between the collimator and the farthest surface of the object was calculated as 41 cm using the equation shown in figure 30. This distance was maintained throughout most of the radiography campaign.

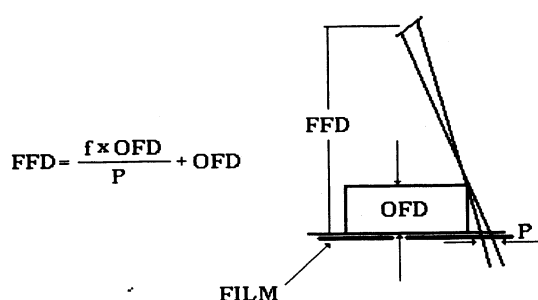

FFD = Focus Film Distance, OFD = Object film Distance, f = Focal Spot Size of the Source
 P = Penumbra or the Geometrical Unsharpness, $f = 4 \text{ mm}$, $\text{FFD} = 400 \text{ mm}$, $P = 0.1 \text{ mm}$
 $410 = (4 \times 10 / p) + 10$

Fig. 30. Calculation of distance of collimator to x-ray film
 (After Gabi Shoef, Ltd.)

Film

Agfa Structurix D-4 and D-7 industrial X-ray film (30 x 40 cm) was used throughout the radiography campaign. In most instances the film was placed inside the ram and the radiation source outside. The positioning was reversed during the radiography of the base plate and the cowl channel in order to allow better film coverage.

Exposure Time

The exposure time was calculated according to the estimated thickness of the object at each exposure location. The wall thickness in most areas is 0.7-1.0 cm, however thicknesses of up to 6.0 cm were measured towards the ram's forward end. The exposure length ranged between 4.5 and 12 minutes. The exposure time was calculated taking into account the film speed, the thickness and density of the penetrated material, the distance of the radiation source from the film, the density (blackening) required on the film, the energy (Kev) and the activity (curie) of the radiation. Preliminary exposure times were calculated using the slide rule provided by the film manufacturer for Ir¹⁹² and steel, using the proper equivalency of bronze to steel. After a few experiments, a correction was calculated for achieving the proper film exposure.

Safety and Radiation in the Museum:

Two radiography sessions were conducted over two working days to complete a full coverage of the ram. During this time, the museum's top floor gallery, where the ram is located, and the gallery below, were cleared of museum staff and the museum was closed to visitors. Museum staff were restricted to areas beyond the radiation limit as defined by readings taken using a Geiger counter during a set of test exposures.

In order to monitor the overall level of radiation in the vicinity of the ram in the top floor gallery, two dosimeters were placed perpendicularly to the ram at a distance of 14.5 m, one each to its starboard and port sides. A dosimeter has the capability to accumulate radiation doses and to display these levels on a readout. These locations were chosen as they represented the areas where the highest levels of radiation were

directed, and where other artifacts were on display.¹⁹⁹ The dosimeters were checked at the end of each working day and the readings were recorded (table 10). A summary of all the exposures taken through the two radiography sessions is given in table 11 in order to provide a general estimate of the total amount of radiation to which the ram was exposed.

Image Processing

With the exception of small areas on the port side cowl, the rest of the ram was radiographed using a total of 47 films. The negative images were then scanned to create data files using a Lumisys Medical Film Digitizer (Model 75) at the Department of Diagnostic Radiology at the MD Anderson Cancer Center in Houston, Texas.²⁰⁰ Data acquired is measured as 2000 samples (pixels) across and 2500 samples down the length of a diagnostic film measuring 14 x 17 inches. This resolution is commonly referred to as 2K resolution. The data was written in a medical file format called DICOM using a PC platform running a Pentium 3/450 MHz processor with 128 MB of RAM and a 10G hard drive. Editing was done in Adobe Photoshop v5.5. The DICOM file format was read into Photoshop using a software plug-in from DesAcc, Inc., called DICOMaccess. The images were edited and their grayscale adjusted to yield the maximum visibility of the features contained in each image. The images were then saved to a JPEG format. This format allows the size of the image file to be reduced by compression algorithms while maintaining high quality image data. The finished collection of files was then burned onto a CD using a Plextor Plexwriter 12/10/32A.

¹⁹⁹ The collection on the top floor of the museum comprises primarily metallic objects with few ceramic, stone and organic objects present.

²⁰⁰ I would like to thank Mr. K.R. Duggan, Coordinator of Image Acquisition, at the Department of Diagnostic Radiology at the MD Anderson Cancer Center in Houston, Texas, for his help in digitizing and processing the radiographic images.

Table 10. Total dosimeter readings at the end of each working day.*

Date	Dosimeter reading at 14.5 m to port (mR)	Dosimeter reading at 14.5 m to starboard (mR)
12/31/00	4	*
01/07/01	105	90
Total mR	109	90

*No dosimeter was placed to starboard during this session since exposures were directed mostly to port.

Table 11. Summary of exposures throughout the radiography campaign.

31 December 2000-Starboard Side					
Location	Film Type	Isotope-Source	Time	Source to Surface Distance (cm)	Comments
SB1	D-7	IR	4.5 min.	40	
SC1	D-7	SE	4.5 min.	40	
SC2	D-7	SE	4.5 min.	40	
SC3	D-7	SE	4.5 min.	40	
SC4	D-7	SE	4.5 min.	40	
SC5	D-7	SE	4.5 min.	40	
SB2	D-4	IR	4.5 min.	40	
SB3	D-4 & D7	IR	4.5 min.	40	underexposed
SB4	D-4 & D7	IR	4.5 min.	40	underexposed
SB5	D-4 & D7	IR	4.5 min.	40	underexposed
SDL1	D-4	IR	4.5 min.	40	
SDU1	D-4	IR	4.5 min.	50	
7 January 2000-Starboard Side					
SDL2	D-4	SE	4.5 min.	40	wrong isotope source
SDL2	D-4	IR	4.5 min.	40	correction
SDU2	D-7	SE	4.5 min.	40	
SD3	D-4	IR	4.5 min.	40	
SD4	D-7	SE	4.5 min.	40	
SB3	D-4	IR	9 min.	40	
SB4	D-4	IR	9 min.	40	

Table 11 Continued

Ramming Head					
Location	Film Type	Isotope-Source	Time	Source to Surface Distance (cm)	Comments
FS	D-4 & D-7	IR	9 min.	40	
FP	D-4 & D-7	IR	9 min.	40	
Port Side					
PB5	D-4	IR	9 min.	40	
PB4	D-4	IR	9 min.	40	
PB3	D-4	IR	9 min.	40	
PB2	D-4	IR	5.5 min	40	
PB1	D-4	IR	5.5 min.	40	
PDL1	D-4	IR	5 min.	40	
PDU1	D-4	IR	5 min.	40	
PDU2	D-4	IR	5 min.	40	
PDL2	D-4	IR	12 min.	40	'Zoom' on helmet
Bottom Plate					
G0	D-4	IR	4.5 min.	40	
G1P,G1S G1SA,G 1	D-4	IR	8 min.	57	
G2P,G2S	D-4	IR	5.5 min.	45	
G3P,G3S	D-4	IR	6.0 min.	40	
G4P,G4S	D-4	IR	5.5 min.	40	
G5	D-4	IR	5.5 min.	40	
Cowl Nosing					
E1	D-4	IR	8 min.	57	Exposed with G1
E4	D-4	IR	5.5 min.	40	
E3	D-4	IR	6.0 min.	40.	
E2	D-4	IR	6.0 min.	40	
Fin (Starboard Top)					
A	D-4	IR	6 min.	35	

APPENDIX C

CHEMICAL ANALYSIS OF CORROSION FROM THE RAM'S CAVITY

A large portion of the interior surface of the ram was encrusted with a coarse greenish-black layer averaging 0.5 cm in thickness. A cross sectional view of a sample removed from the surface indicates a layered structure varying in density and texture and often exhibiting a metallic sheen. Since many ancient hollow cast bronzes have been found with core remains in their cavities, special attention was paid to the material inside the ram. A sample of the crust was removed for chemical analysis at the Geology and Geophysics Department Electron Microprobe Lab at Texas A&M University, in order to establish its nature and origins.²⁰¹

Procedures

The sample was mounted in epoxy resin and polished using diamond pastes followed by vacuum-coating with a thin film of carbon, in order to make the entire polished surface electrically conductive. Subsequent compositional analyses were carried out using a four spectrometer Cameca SX50 electron microprobe at an accelerating voltage of 15 kV and a beam current of 10 nA. Qualitative analyses (spectra) were obtained with an Imix Princeton Gamma Tech (PGT) energy dispersive system (EDS) using a thin-window detector. All quantitative work employed wavelength-dispersive spectrometers (WDS). Analyses were carried out after standardization using very well characterized compounds or pure elements.

Typical accuracy for major elements (>10% wt) is about +/- 1-2% of the amount present. The uncertainty at lower concentrations increases as the concentration

²⁰¹ The microprobe work was carried out by Dr. Ray Guillemette of the Geology and Geophysics Electron Microprobe Lab at Texas A&M University in College Station, Texas. I would like to thank Dr. Guillemette for conducting the analytical work and for his help with the interpretation and graphic presentation of the results.

decreased, with the uncertainty reaching 100% at the lower limit of detection. The lower limit of detection for most elements is typically about 0.05-0.10% wt.

X-ray maps were obtained at 15 kV and 30 nA beam current. The stage was rastered beneath the beam in a 1024 x 256 point grid, with a grid spacing of 7 microns and a dwell time of approximately 16 milliseconds at each point. Two passes were made to obtain a backscattered electron (BSE) image and maps of all of the elements (oxygen, silica, sulfur, copper, and tin). Total time for acquisition of all the maps was about two hours.

Qualitative Analysis

Qualitative analysis (EDS) was carried out at four different locations across the sample (*A*, *B*, *C*, and *D*, see fig. 31). These locations were chosen as they are representative of the most noticeable features observed across the sample. The analysis results for each sample location are plotted on four graphs (fig. 32). They characterize the nature of the material and indicate the presence of high levels of copper, tin, and sulfur, as well as small amounts of carbon originating from the carbon coating.

Quantitative Analysis

Quantitative analyses were performed at the approximate locations of *A*, *B*, *C*, and *D*. They show variations in the concentrations of copper, tin, sulfur and oxygen across the sample, with tin and copper changing the most (table 12). In order to better understand the distribution of the major elements across the sample, separate "maps" were acquired showing the distribution of generated characteristic x-rays from each of the elements (brighter means larger number of x-rays). A BSE image was also simultaneously acquired; brightness represents mean atomic number (fig. 33). The X-ray maps indicate that the areas closest to the surface of the object (shown on the left side of the map) contain high levels of tin and copper.

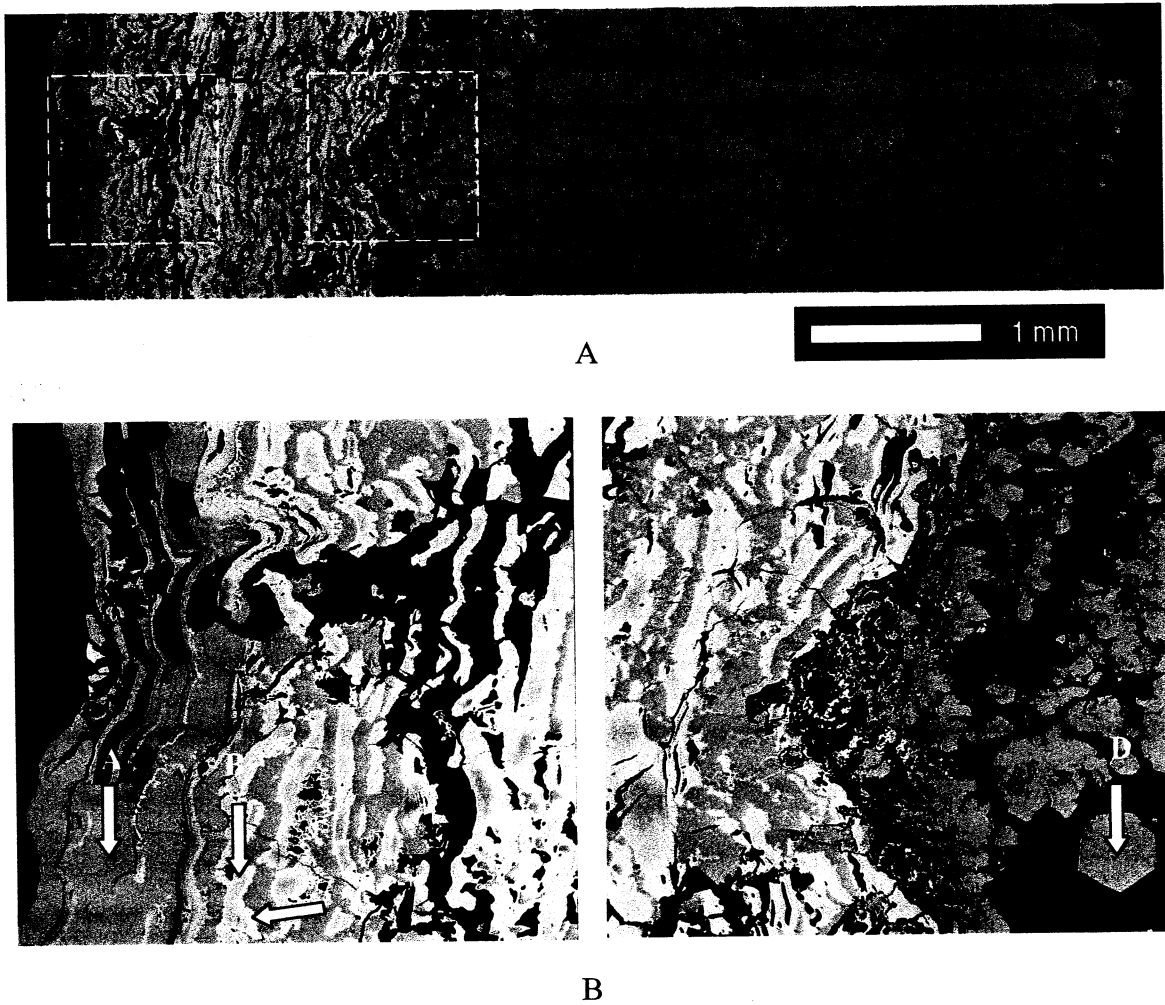

Fig. 31. Cross-sectional views of polished crust sample obtained as BSE: *A*, complete cross section; *B*, enlarged areas (marked by white frames in *A*) showing the locations of the EDS qualitative analyses sites (1 mm square).

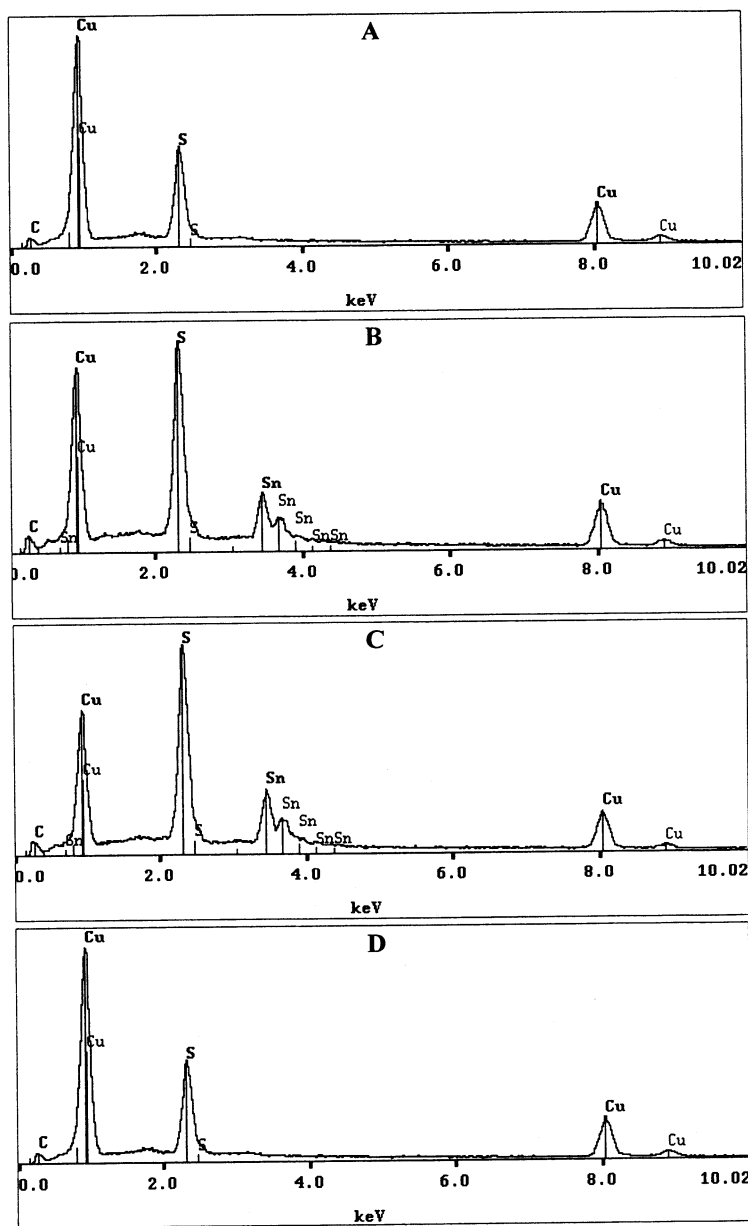

Fig. 32. Plotted values of EDS qualitative analysis.

Table 12. Quantitative analyses in weight percent, at the approximate locations *A, B, C, D*.

	A	B	C	D
Cu	78.294	40.103	38.854	78.245
Sn	0.000	32.667	32.599	0.000
S	21.269	27.121	27.505	20.567
Total	99.563	99.891	98.958	98.812

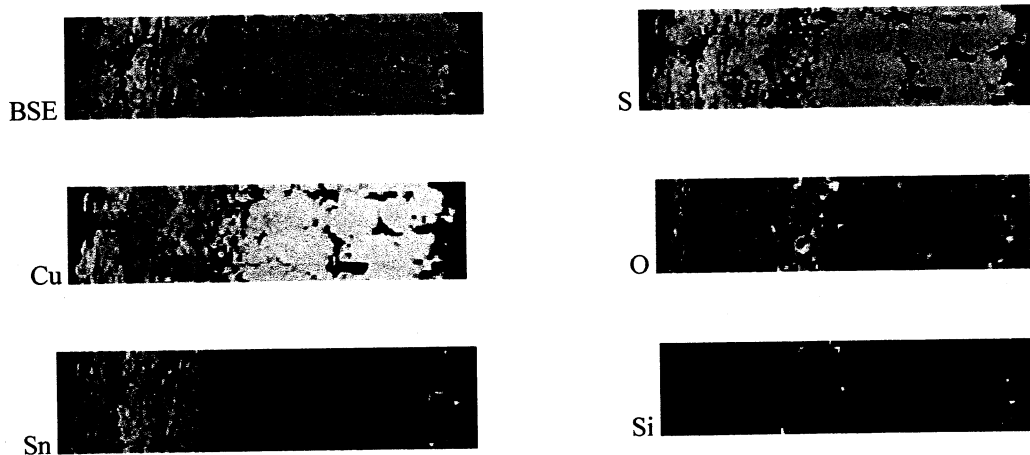

Fig. 33. BSE image of individual elements. Each map shows the distribution of one element across the sample (the length of each image is approximately 7 mm).

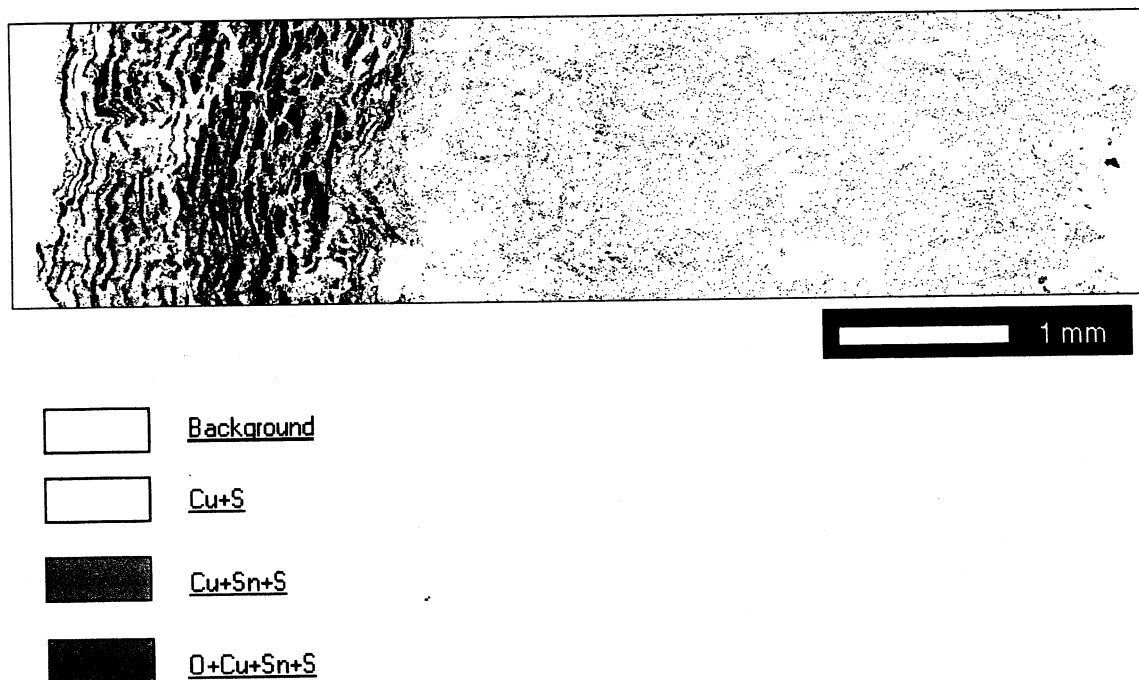

Fig. 34. Composite, false-color x-ray map. The image was digitally enhanced to show the main elements in their most likely chemical combinations.

The level of tin drops as the distance from the surface increases, while the level of copper remains high throughout, with the highest concentration being in the interior. The distribution of sulfur is also relatively uniform but that of oxygen and silica is more variable. The combined values of these elements (excluding silica) are presented in a composite false-color x-ray map that was digitally enhanced to show main elements in their most likely chemical combinations (fig. 34).

In conclusion, the overall composition of the crust sample indicates that it is a corrosion layer formed over time, rather than the remains of casting material. The layered structure of the crust and the overall distribution of the analyzed elements, with high tin levels near the object's surface, and high concentration of copper throughout, most likely reflect variations in the chemical environment with time during the formation of the different corrosion products. The localized presence of silica on the exterior surface of the sample may hint to its origin in the sand grains from the surrounding deposit. The alternating oxygen – and – sulfide – bearing layers suggest variations in the redox potential during burial, with a tendency towards an anaerobic environment. The latter is often characterized by sulfur-based corrosion products.²⁰²

²⁰² North and MacLeod 1987, 80-3.

DRAWINGS

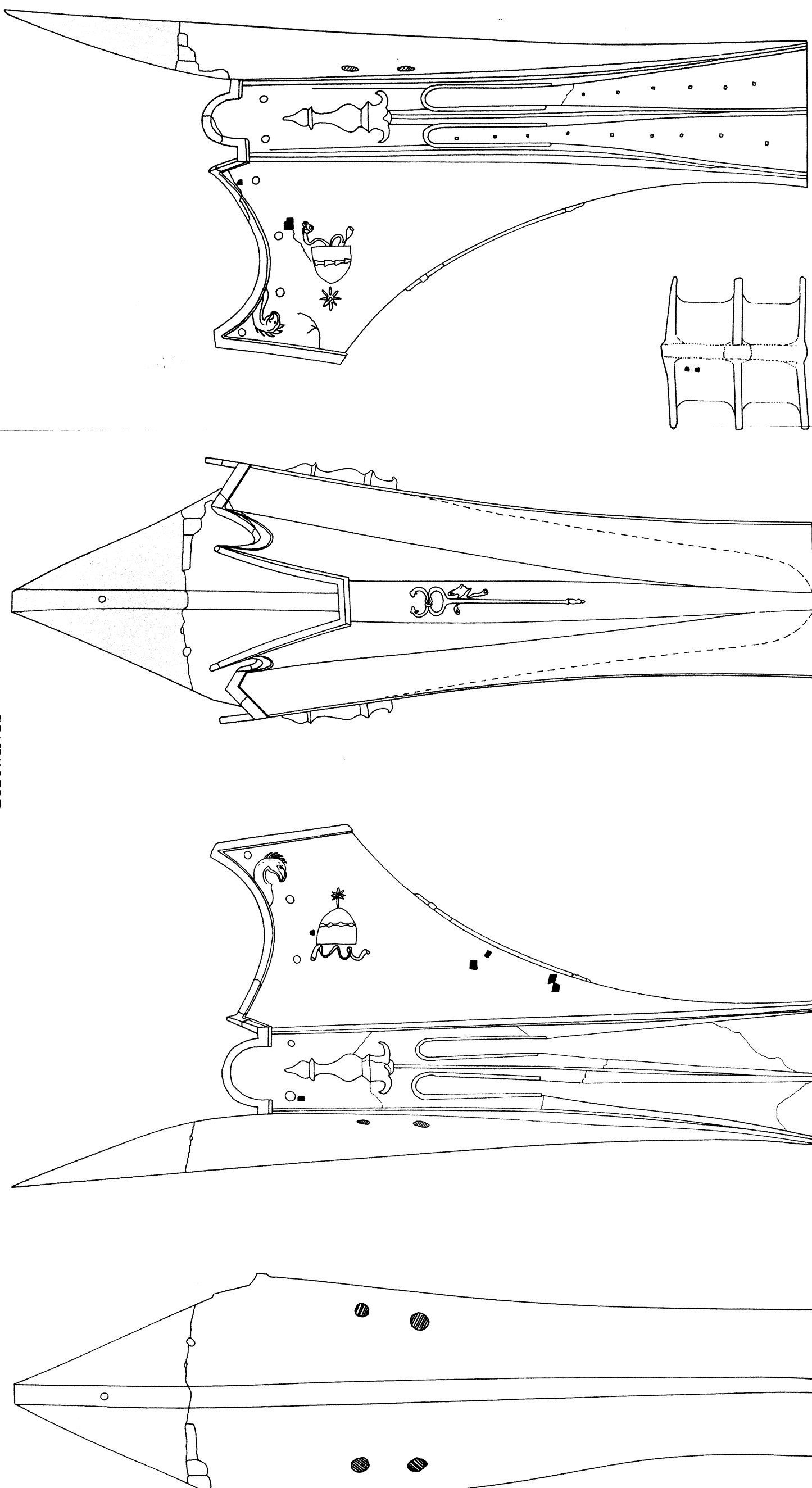

Metallurgical repairs

Mechanical repair patces

Protrusions (cut lugs?)

Areas covered with concretion and/or corrosion

AB

A ← B →

0 10 20 30 40 50 cm

RADIOGRAPHIC PHOTOMOSAICS

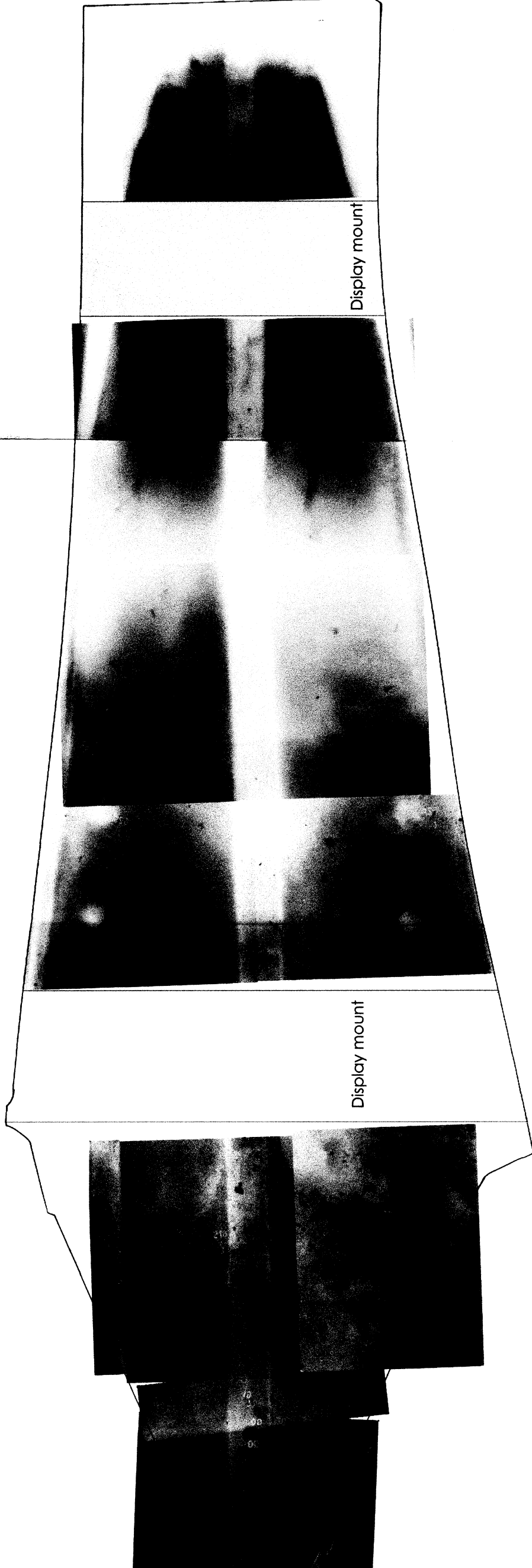

0 10 20 30 40 50 cm

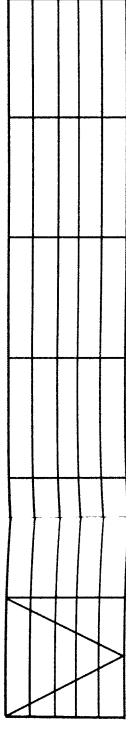

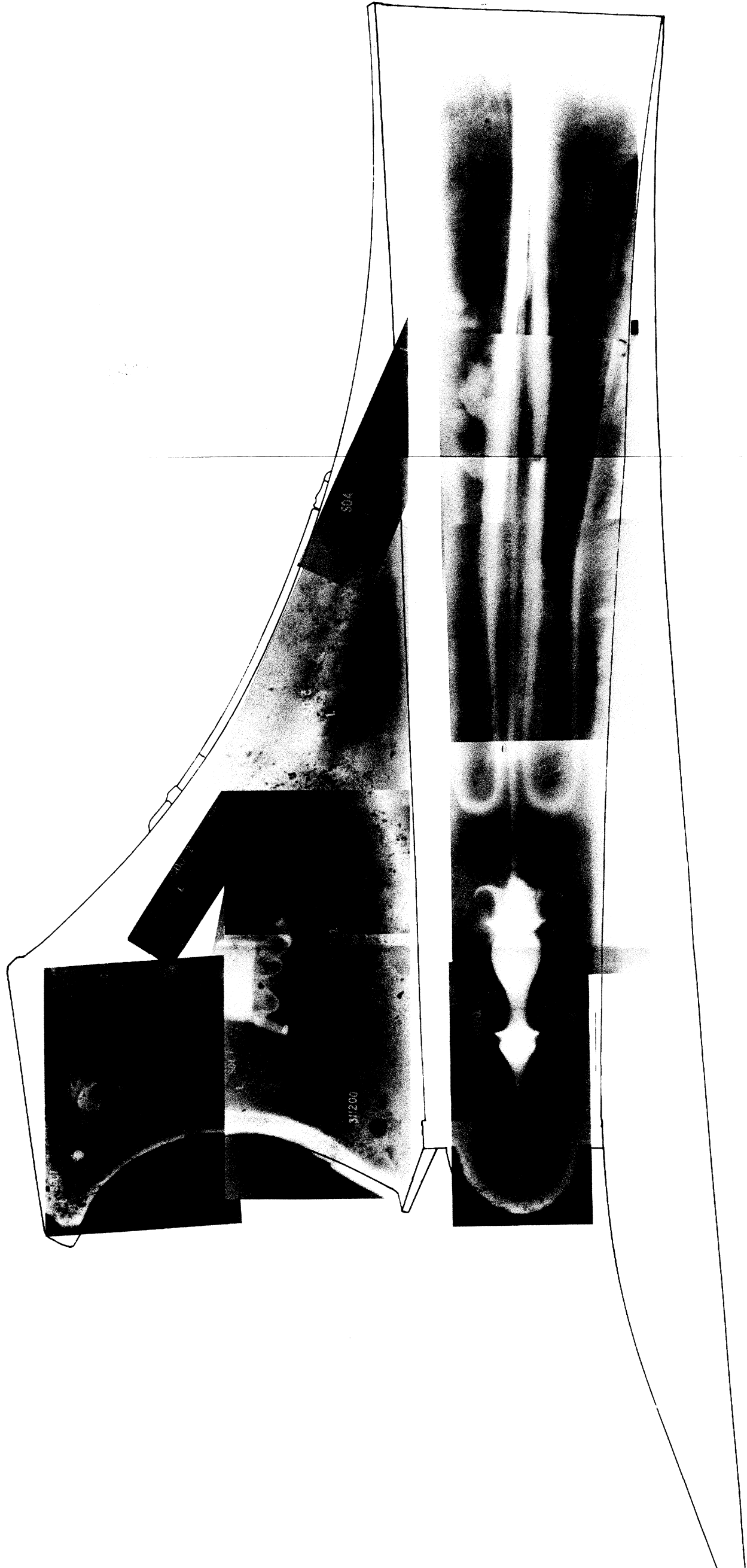

0 10 20 30 40 50 cm

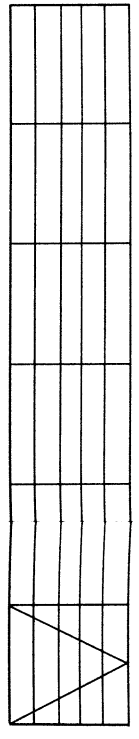

S04

S1/200

0 10 20 30 40 50 cm

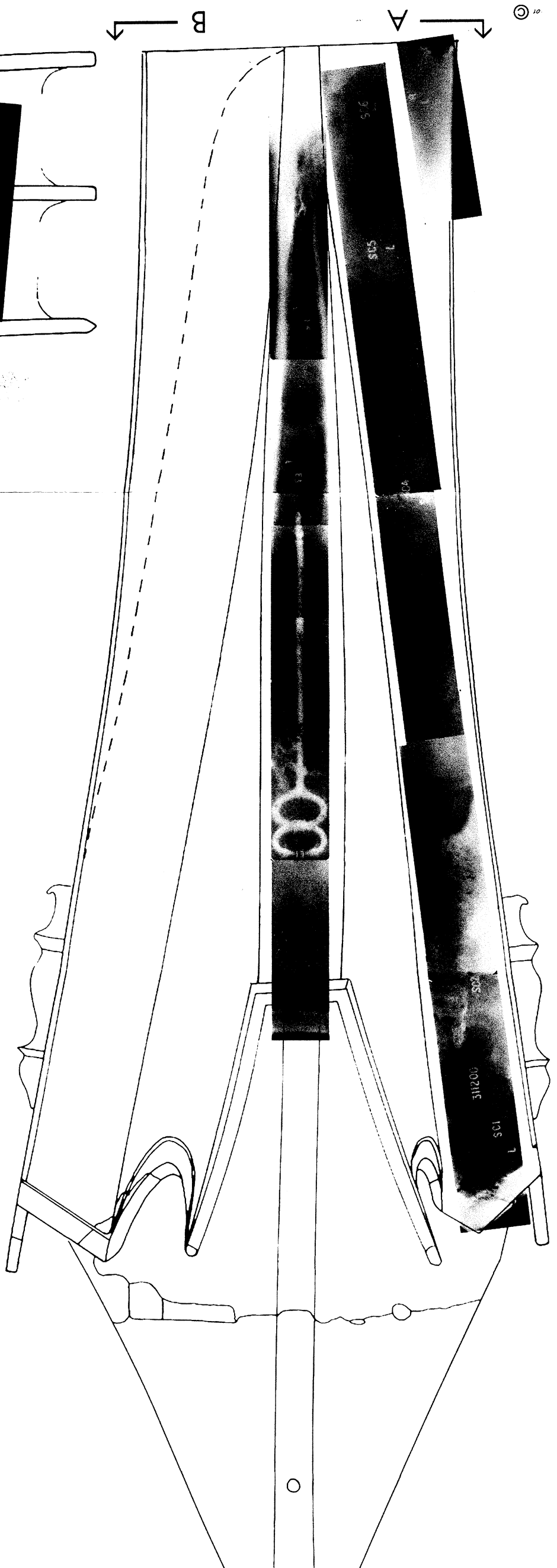
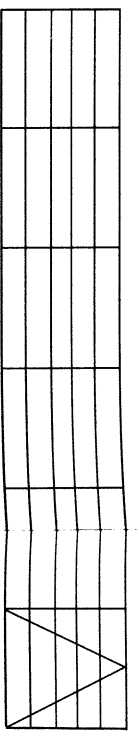

AB

B

A

311200
L SCI

315

315

○

DISTRIBUTION OF CHAPLETS VISIBLE ON RADIOGRAPHS OF THE RAM

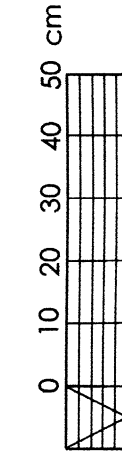
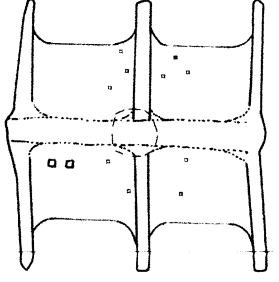
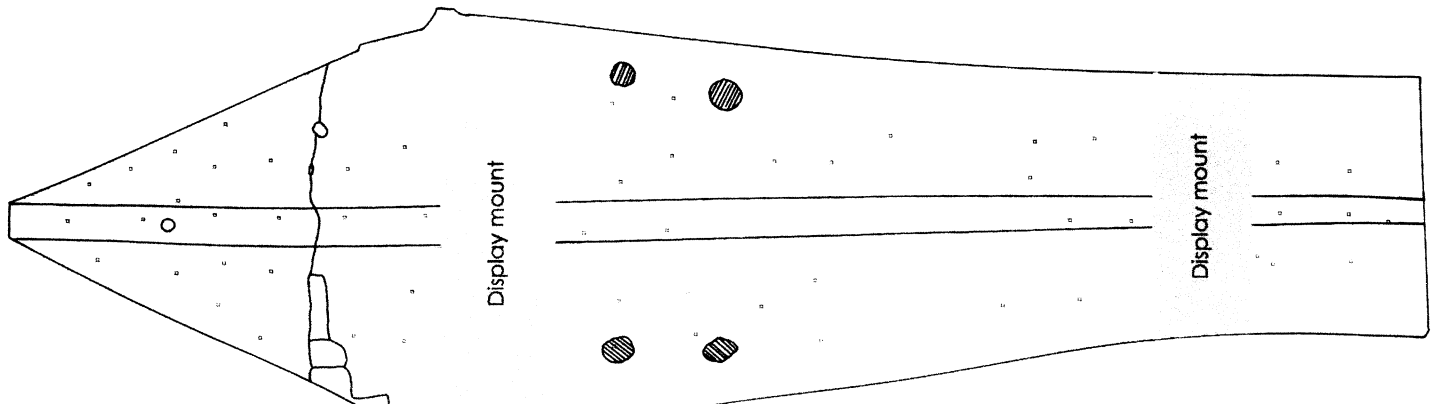
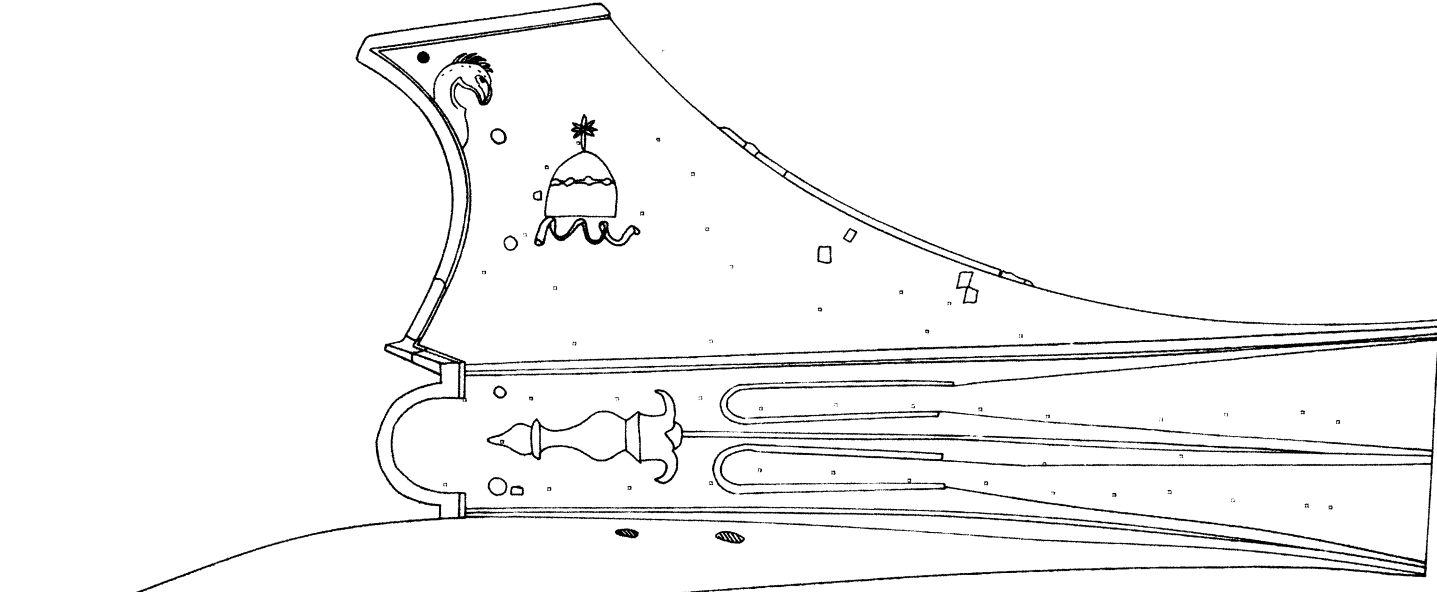
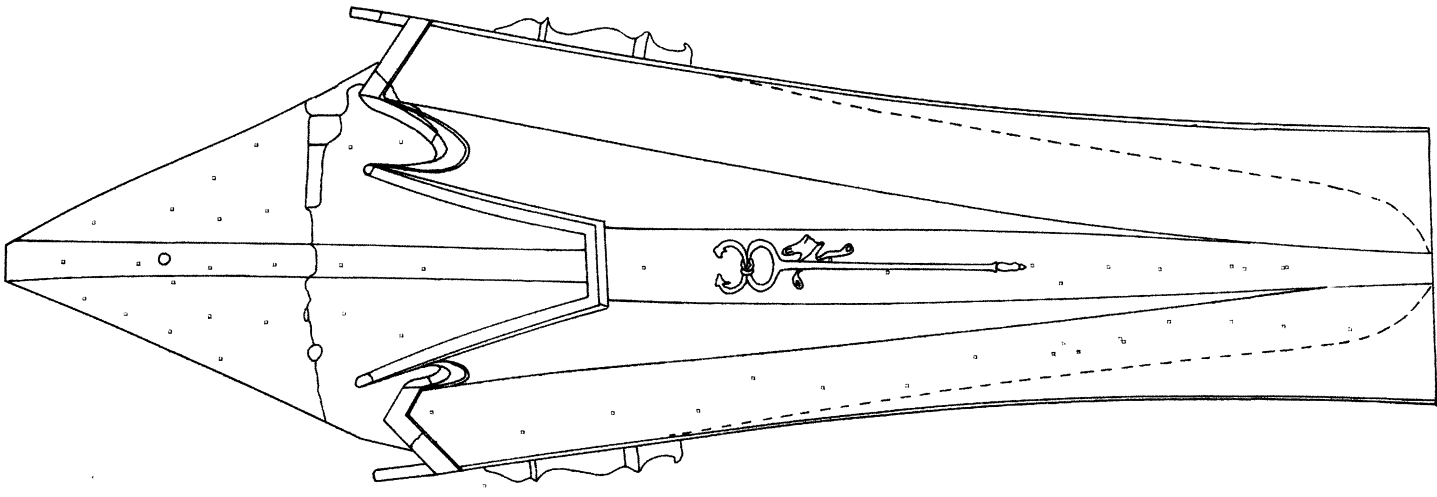
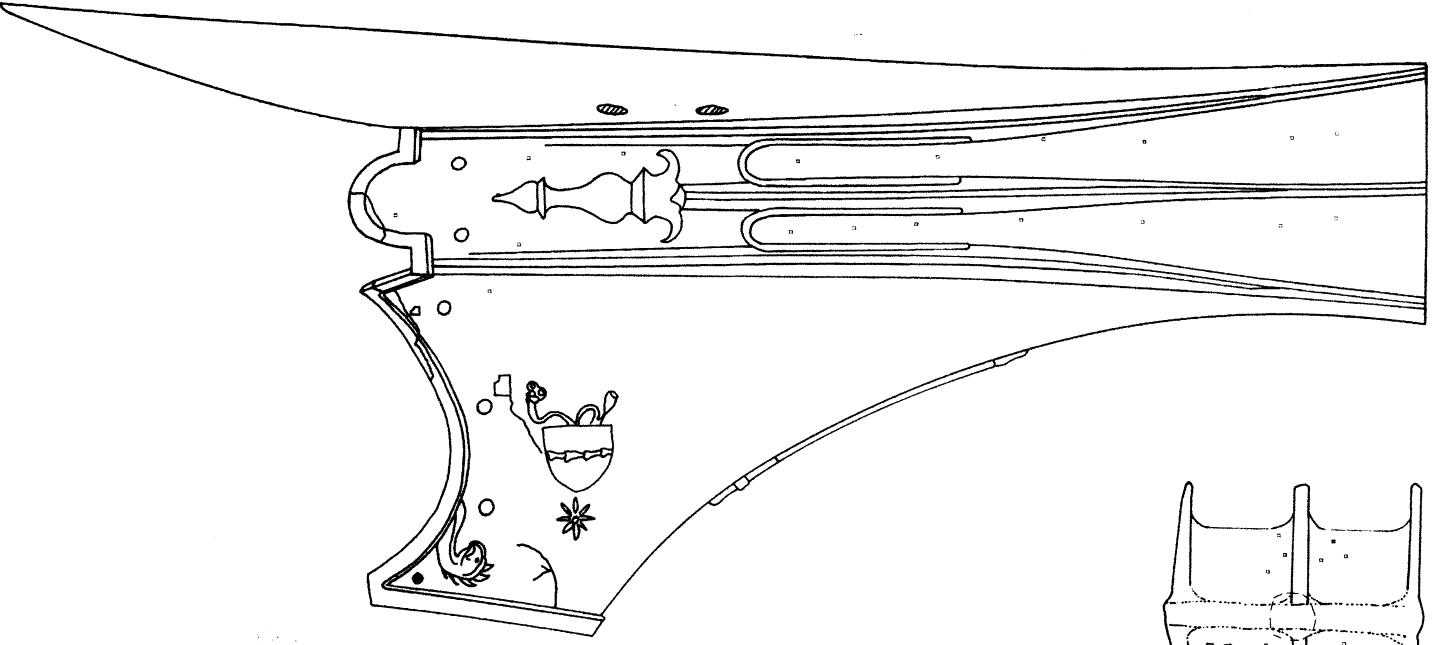

A ← → B

AB

APPENDIX G

LETTERS OF PERMISSION AND COPYRIGHTS



21 אוגוסט 2000

לכבוד
 אסף ארון
 אוניברסיטת טקסס, ארה"ב
 פקס: 778434352

הריני לאשר לך את ביצוע הדגימות, בהתאם להגבלות של פרופ' אלישע לימדר.
 תיאום פגישה מראש במוזיאון הימי יש לעשות מול מנהל המוזיאון הימי ישירות.
 בסיום המחקר נא העבר עותק מעבודתך לספריה ברשות העתיקות.

 בברכה
 חוה כץ
 מנהלת תחום אוצרות המדינה

העתק: מר אבשלום זמר



אוניברסיטת חיפה
UNIVERSITY OF HAIFA

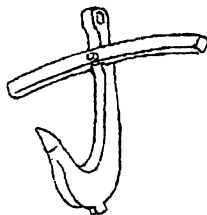

מזיאון הספינה העתיקה ממעגן מיכאל
MA'AGAN MIKHAEL ANCIENT SHIP MUSEUM



המכון ללימודים ימיים
THE INSTITUTE FOR MARITIME STUDIES

בפקס: 02-6273410

21/08/00

לכבוד:

גבי חוה כץ
ממונה על תחום אוצרות
רשות העתיקות
ת.ד. 586
ירושלים 91004

הנדון: בקשתו של מר אסף אורון בנוגע לאיל הנגיחה מעתלית

חוה יקרה,

אפתח בפריסת שלום ובהזדמנות זו אשוב על הזמנתי לארח אותך שוב במוזיאון הספינה ובקיבוץ מעגן מיכאל בחודשי הקיץ החמים הללו.

בנוגע לבקשתו של מר אסף אורון להוצאות דגמים מגוף איל הנגיחה ובהמשך להכוונתך אותו אלי בנידון, הריני מאשר בזאת הוצאת דגמים למטרת מחקר שהוא עורך, בכפוף לתנאים הבאים לביטוי בבקשתו המצורפת. דהיינו:

Micro metal sampling – 5-10 samples of 50-100 ml. Each

כמוכן Cross section של מסי מ"מ לבדיקות מטלוגרפיות מאזורים מוסתרים.

כל היתר בהתאים לאישורים ולתנאים שלך.

בברכת קיץ נעים וקריר עד כמה שניתן.

בנידונות,
אלישע.

העתק: מר אבשי זמר – מנהל המוזיאון הימי הלאומי – חיפה.

הר הכרמל, חיפה 31905, Israel 31905
טל: 972-(0)4-8240 450 Tel: 972-(0)4-8240 724 פקס: 972-(0)4-8240 724
E-Mail: elisha@research.haifa.ac.il Website: http://multimedia.haifa.ac.il/maagan

Asaf Oron has permission to reproduce drawing of the Athlit ram done by J.R. Steffy. These drawings are found in *The Athlit Ram* published by Texas A&M University Press in 1991. The drawings in question are 2.7, 2.13, 2.15, 2.24. This will be for use in his thesis to be submitted to Texas A&M University as a requirement for completion of a Master's of Arts degree in Anthropology.

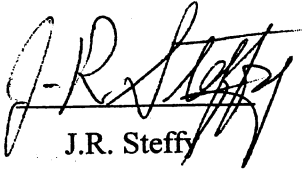
J.R. Steffy

10/27/01
Date

VITA

ASAF ORON

Moshav Avigdor, 83800 Israel

asaforon@aol.com

(972) 8 8581180

EDUCATION

Institute of Archaeology, University College London, B.Sc. in Archaeological Conservation, May 1994. Thesis: *The Conservation of Waterlogged Shale*.

EXPERIENCE

Tektaş Excavation (INA), Tektaş Burnu, Turkey
Head Conservator *May 1999 to August 2001*

Samuel H. Kress Fellowship for Advanced Training in Conservation, INA Conservation Laboratory, Bodrum, Turkey: Conservation Research Laboratory, Texas A&M University, College Station, Texas *September 1998 to May 1999*

Leon Levy Shipwreck Survey (INA), Ashkelon, Israel
Project Conservator *November 1997*

The Metropolitan Museum of Art, New York, Greek and Roman Collections Reinstallation Project
Objects Conservator *January 1997 to June 1998*

Bozburun Excavation (INA), Selimiye, Turkey
Head Conservator *June 1995 to December 1998*

Andrew W. Mellon Conservation Fellowship, Sherman Fairchild Center for Objets Conservation, The Metropolitan Museum of Art, New York
Fellowship Student *September 1994 to December 1996*

PUBLICATIONS

Oron, A. 2001. "Conservation on the Rocks at Tektaş Burnu." *INA Quarterly* 28:8-10.

Oron, A., and J. Pannell. 1996. "The Institute of Nautical Archaeology: Bozburun Shipwreck Excavation Site." In *Archaeological Conservation in Turkey, Kaman Kalehöyük Symposium Report June 26-28*, edited by G. Wharton 22-3. Middle Eastern Culture Center: Japan.