

WATERSCHIP NZ421: A LATE MEDIEVAL FISHING VESSEL  
FROM FLEVOLAND, THE NETHERLANDS

A Thesis

by

RALPH KENNETH PEDERSEN

Submitted to the Office of Graduate Studies  
of Texas A&M University  
in partial fulfillment of the requirements for the degree  
of

MASTER OF ARTS

May 1991

Major Subject: Anthropology

WATERSCHIP NZ421: A LATE MEDIEVAL FISHING VESSEL  
FROM FLEVOLAND, THE NETHERLANDS

A Thesis

by

RALPH KENNETH PEDERSEN

Approved as to style and content by:

F. H. van Doorninck, Jr.  
F. H. van Doorninck, Jr.  
(Chair of Committee)

James C. Bradford  
James C. Bradford  
(Member)

J. Richard Steffy  
J. Richard Steffy  
(Member)

Vaughn M. Bryant  
Vaughn M. Bryant  
(Head of Department)

May 1991

## ABSTRACT

Waterschip NZ42i: A Late Medieval Fishing Vessel

From Flevoland, The Netherlands. (May 1991)

Ralph Kenneth Pedersen, B.A., SUNY at Stonybrook

Chair of Advisory Committee: F. H. van Doorninck, Jr.

In this thesis, the clinker-built waterschip, NZ42i, is reconstructed. Reference is made to waterschip W10 and depictions of waterschepen from the seventeenth through twentieth centuries in resolving problematic aspects of the reconstruction. The form and constructional features of NZ42i are compared with those of other types of vessels of northwestern Europe to ascertain the vessel's place among the traditions of northwestern European boatbuilding. A comparison is also made with the form and constructional features of the carvel-built waterschip W10 to establish similarities, as well as differences resulting from the disparate methods of construction. Various structural features of NZ42i are examined for their strengths, weaknesses, or function, models being employed in some instances.

This study is the only study of a clinker-built waterschip and the only detailed study of the general vessel type that has been undertaken to date.

DEDICATION

To kindred spirits

For will anyone dare to tell me  
that business is more entertaining  
than fooling among boats?

-From An Inland Journey by Robert  
Louis Stevenson

## ACKNOWLEDGEMENTS

I would like to thank my parents and brother for their love and support through some very lean years.

In addition, I extend my thanks to the members of my committee, and to the people who read through this work, at least in part: my father-in-law Joseph Polera and my good friend and colleague Michael A. Fitzgerald, who, with his good humor and invaluable advice, made the road a little easier. I give special thanks to Dr. Kent Lightfoot for his encouragement in pursuing a career in archaeology and to Dr. Aaron Carton of the linguistics department at SUNY at Stonybrook, whose enthusiasm for teaching and his students is inspiring and unsurpassed.

Most of all, I would like to thank my wife Martha, whose sacrifice and support without complaint has been nothing short of a blessing.

## TABLE OF CONTENTS

	page
ABSTRACT .....	iii
DEDICATION .....	iv
ACKNOWLEDGEMENTS .....	v
TABLE OF CONTENTS .....	vi
LIST OF TABLES .....	viii
LIST OF FIGURES .....	ix
CHAPTER	
I        INTRODUCTION .....	1
II        CIRCUMSTANCES OF THE FIND .....	5
III        DESCRIPTION OF THE WRECK .....	8
The Keelplank .....	11
The Stem .....	12
The Sternpost .....	18
Planking .....	19
Repairs to the Hull .....	28
The Framing .....	32
The Stringers .....	51
The Decks .....	58
Additional Timbers .....	80
Mast and Rigging.....	81
Ballast .....	81
Artifacts .....	84
IV        RECONSTRUCTION AND METHODOLOGY .....	92
Introduction .....	92
Keelplank and Posts .....	94
The Lines and the Planking Model .....	95
The Planking .....	106
The Shape of the Vessel .....	110
The Framing .....	114
The Stringers .....	118
The Decks .....	120
The Sections .....	126
The Steering Arrangement.....	126

	The Mast and Rigging .....	139
	The Cabin .....	147
	Conclusion .....	148
V	ANALYSIS .....	150
	Introduction .....	150
	The Date of NZ42i .....	151
	The Keelplank .....	151
	The Stem .....	154
	The Planking .....	163
	The Framing .....	179
	The Fishwell .....	183
	Longitudinal Timbers .....	193
	The Caulking .....	194
	The Decks .....	195
	Ballast .....	208
	Artifactual Remains .....	211
	NZ42i and Comparative <u>Waterschepen</u> ....	212
VI	THE <u>WATERSCHIP</u> : ITS HISTORY AND ORIGIN ...	214
	The History of the <u>Waterschip</u> .....	214
	The Origin of the <u>Waterschip</u> .....	218
VII	SUMMARY AND CONCLUSIONS .....	227
	The Change to Carvel Construction ....	227
	Zuider Zee Shipbuilding and <u>Waterschepen</u> .....	231
	The Literary Evidence .....	231
	Future Research .....	233
	NOTES .....	236
	REFERENCES .....	237
	APPENDIX: LETTERS OF PERMISSION .....	244
	VITA .....	253

## LIST OF TABLES

Table	page
1. Strake details.....	27
2. NZ42i and comparative <u>waterschepen</u> .....	213

## LIST OF FIGURES

Figure	page
1. Map of the IJsselmeer with approximate location of wreck site shown .....	6
2. Profile of the wreck showing the longitudinal distortion of the vessel .....	9
3. Stereophotograph of the wreck with the overburden removed .....	10
4. The stem .....	13
5. Drawing of the stem with joints, fastenings and other details shown .....	14
6. Detail of the stem top .....	17
7. A view of the wreck from the bow .....	20
8. Stereophotograph of the wreck excavated to the planking .....	21
9. Sketch of the type of sintel commonly found on <u>waterschepen</u> .....	23
10. The planking to starboard inside the fishwell ...	25
11. The planking to port in the fishwell .....	26
12. Stereophotograph of the wreck excavated to the framing .....	33
13. Detail of the fastenings .....	34
14. The remaining futtocks to starboard in the bow .....	36
15. The scarfs of futtocks to floor timbers to starboard in the bow .....	37
16. The stringers to port in the bow .....	39
17. The scarfs of futtocks and floor timbers to port .....	40
18. The mast socket and the pump notch .....	41

19. A view from the bow .....	42
20. Sketches of two frames from the bow and the grain patterns .....	43
21. The frames in the stern .....	45
22. The stern floor timbers .....	46
23. A view of the wreck from the stern with the decks removed .....	47
24. Detail of the frames to port in the after half of the fishwell .....	50
25. The forward section of the wreck before final cleaning .....	53
26. The mast step, chocks and bottom stringers .....	54
27. The stringers in the stern as viewed from the port side with the ceiling removed .....	57
28. The stern deck, living quarters and fishwell deck as viewed from the port stern quarter .....	60
29. Detail of the caulking laths on the stern deck ..	62
30. Drawing of a half beam and associated timbers .....	66
31. Two views of the port kingplank showing the mortises and notch for the mast partners .....	69
32. The fishwell deck viewed from starboard with the starboard knees set back in place .....	72
33. Drawing of the trough .....	74
34. The fishwell deck viewed from port .....	76
35. A plank with an apparent hood end, treenail holes and nail holes .....	82
36. Detail of Fig. 35 .....	83
37. The mast foot with its supporting ballast pile .....	85

38. The pieces of the winch .....	90
39. Comparison between reconstructed and actual sections of the wreck .....	96
40a. Graphs of the widths of the first through third strakes on both sides of the vessel .....	98
40b. Graphs of the widths of the fourth through sixth strakes on both sides of the vessel .....	99
41. The model before planking .....	102
42. The completed planking model of NZ42i .....	107
43. Lines drawing of NZ42i .....	108
44. The reconstructed planking of NZ42i .....	109
45. The <u>waterschip</u> as depicted by B. Florisz from his map "Kaart van Amsterdam," 1625 .....	112
46. An anonymous engraving of a <u>waterschip</u> from 1600 .....	113
47. The reconstructed framing of NZ42i .....	115
48. Section 1- a. as found, b. reconstructed .....	127
49. Section 2- reconstructed .....	128
50. Section 3- reconstructed .....	129
51. Section 4- reconstructed .....	130
52. Section 5- a. as found, b. reconstructed .....	131
53. Section 8- a. as found, b. reconstructed .....	132
54. Section 9- a. as found, b. reconstructed .....	133
55. Section 10- a. as found, b. reconstructed .....	134
56. Section 11- a. as found, b. reconstructed .....	135
57. Section 12- a. as found, b. reconstructed .....	136
58. Section 13- a. as found, b. reconstructed .....	137

59. The forwardmost stern deck beam .....	138
60. The stem top of W10 .....	140
61. A drawing of a late <u>waterschip</u> .....	141
62. <u>Waterschepen</u> towing a ship set in <u>scheepskameelen</u> .....	142
63. A depiction of a <u>waterschip</u> by Reiner Nooms, circa 1655 .....	143
64. A comparison of the stems of NZ42i and W10 .....	155
65. Beaching the stem without the runners .....	161
66. Beaching the stem with the runners .....	162
67. The deflecting action of the runners .....	164
68. The hole through the hull .....	176
69. Photograph of the model planks .....	190
70. The graph comparing the deflection of the model planks plotted by weight vs. amount of deflection .....	191
71. The <u>Ilmenau Ever</u> .....	197
72. The mast socket of the Kollerup Cog .....	199
73. Frames of the Druten Barge, Zwammerdam 2 and K73/74 compared to rider beams of NZ42i .....	203
74. Comparison of a section of NZ42i and a section of the Bremen Cog .....	207
75. Map of the Netherlands with the source of ballast and important fishing towns shown .....	210
76. The Ebersdorf model .....	221
77. Comparison of a section of NZ42i and a section of the Ebersdorf model .....	223

## CHAPTER I

### INTRODUCTION

This is the first study of a waterschip with clinker constructional features ever undertaken. Nor is any other research on the type currently in progress. Consequently, the reconstruction presented in this thesis yields the first view of a clinker-built waterschip in four centuries.

The reconstruction of NZ42i1 utilized excavation notes, photographs, and stereophotographic plottings of the wreck provided by the Rijksdienst voor de IJsselmeerpolders (RIJP). In addition, comparisons were made with a carvel-built waterschip, W10, artistic representations of waterschepen and other types of vessels, both earlier and later, in order to avoid anachronisms in the reconstruction. None of the timbers of NZ42i were seen or examined by the author.

Today in the polderlands, an experienced team of six from the Museum voor Scheepsarcheologie at Ketelhaven, under the direction of Reinder Reinders, conducts highly

---

The thesis follows the style of the International Journal of Nautical Archaeology.

professional and thorough excavations (Reinders, 1982: 15). All data are recorded and all of a wreck's timbers and planking are drawn to scale using a pantograph. However, in the 1970's when NZ42i was excavated, this was not the case. Whether due to a lack of funding or training, much information about NZ42i was not recorded. Few of the timbers were drawn, many measurements for key hull members were not taken and the sizes and locations of fastenings were generalized. Such items as tool marks were ignored, and wood grain patterns were recorded for only two floor timbers. Nevertheless, the reconstruction of the vessel was achieved by painstakingly calculating dimensions from photographs and drawing on inferences from the recorded measurements.

This study presents the waterschip NZ42i in its two states: an unknown wreck and the vessel it once was.

Chapter II describes the circumstances of the finding and initial investigation of the wreck.

Chapter III is a straightforward description of the remains of the vessel. All dimensions, whether found in the excavation notes or taken from the photographs, are presented here.

In chapter IV, the reconstruction process and its result are presented narratively and graphically in a

methodical manner using lines drawings, models, and diagrams of the hull and decks. The resultant reconstruction is compared to the only other reconstructed waterschip, W10, and to depictions of waterschepen.

Chapter V is devoted to an analysis of the vessel. In this chapter, various components of the reconstructed NZ42i are analyzed for strength, function and stability; compared to other archaeological finds; and placed in proper historical context. In addition, a comparison is made with dimensions obtainable from waterschip descriptions, models, and lines drawings of the past few centuries.

In chapter VI, the history of the waterschip as garnered from various Dutch sources is presented. This is the first time this information is made available in English. In addition, an attempt is made to trace the origin of the waterschip based on its form and construction features.

The excellent preservation of NZ42i has provided insights into the clinker-building techniques, as well as caulking, framing and deck construction methods of the medieval Netherlands.

The importance of NZ42i derives from not only the medieval shipbuilding methods it exhibits but also how the vessel compares with the carvel waterschip W10, which it possibly predates by half a century. One aim of the thesis was to discover how the builders adapted the type and building methods to the carvel technique. On a more general level, this is one of the more important questions in shipbuilding history (Reinders, 1982: 21).

Equally important is the comparison between waterschip NZ42i and clinker-built vessels of other times and areas of northwestern Europe. Thus, an attempt was made through this study to further define not only the medieval Dutch style of construction but also particular constructional characteristics of the medieval Zuider Zee region. Such comparisons have also demonstrated the relationship of NZ42i to the Celtic shipbuilding tradition of ancient Europe, as will be seen below.

## CHAPTER II

### CIRCUMSTANCES OF THE FIND

On October 29, 1975, a telephone call from Hr. B. Proem, a land reclamation superintendant, alerted the archaeologists at the Museum voor Scheepsarcheologie at Ketelhaven to the discovery of a shipwreck located near the town of Spakenburg in lot 42 of Flevoland's southern polder (Fig. 1). An exploration of the wreck was immediately undertaken by J. v.d. Land and H. van Heen.

The wreck was located 100 m. from the drainage ditch dividing lots NZ42 and NZ43 and 125 m. from the ditch dividing lots NZ42 and NZ46.

The preliminary exploration revealed the wreck to be approximately 13 m. long and 5.9 m. broad. Through probing with an iron pike, the existence of a ballast pile was determined, and the depth of the wreck was found to be 1.5 m. It was also noted that the wreck had suffered some damage from drainage machines. These machines had also dislodged some ballast stones which were subsequently found lying in a drainage ditch.

The investigators found that the wreck was of a clinker-built vessel which they tentatively dated to the fifteenth to seventeenth centuries.

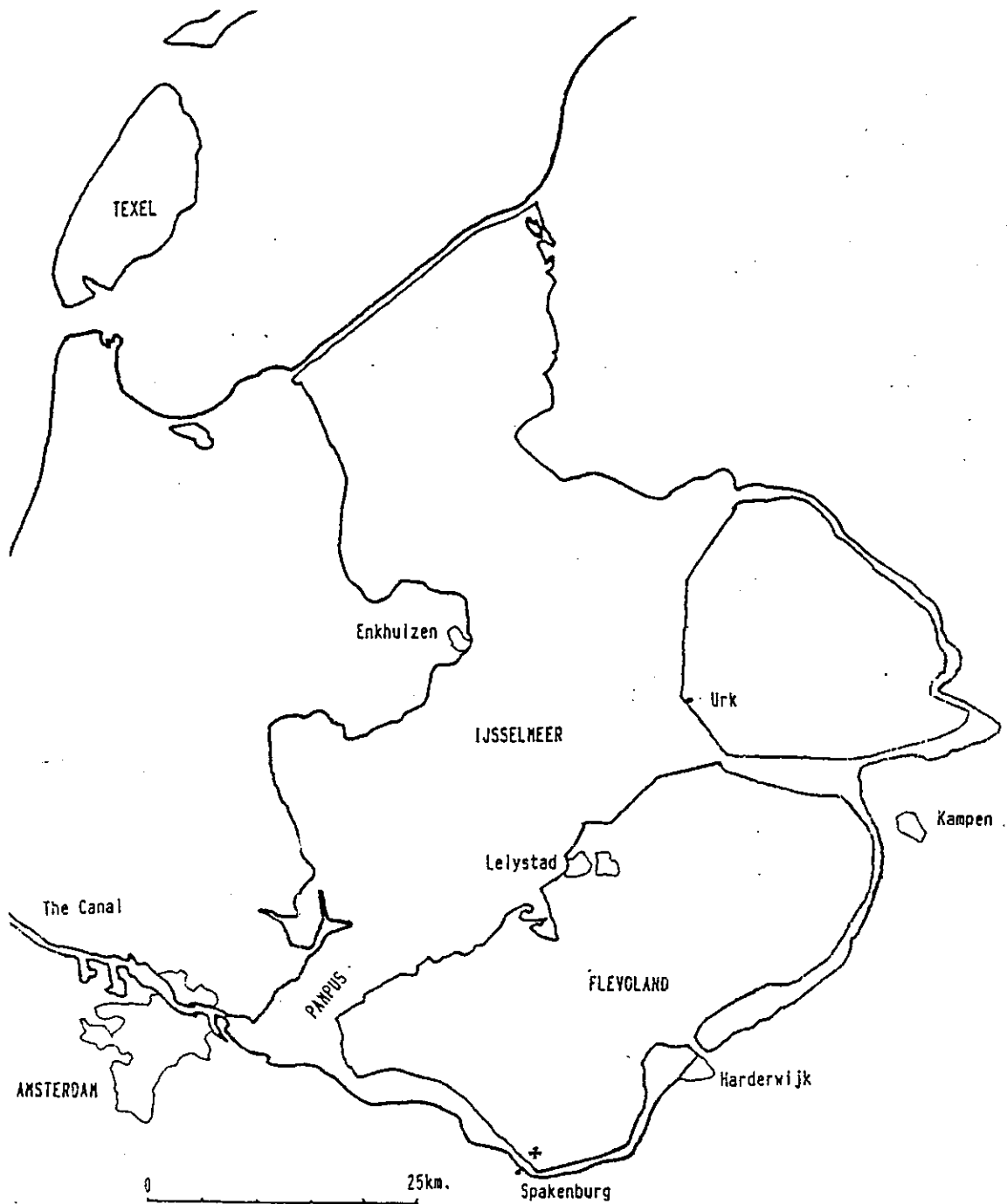

Figure 1. Map of the IJsselmeer with approximate location of wreck site shown.

The wreck was protected against further damage by marking the area with poles and then was left to be excavated at some future date. The wreck was given the code name NZ42i after the lot number in which it was found, Nederlands Zuidelijk kavel (lot) 42. The "i" indicates that this was the second wreck to be found on the lot, the first being the cog NZ42 (Reinders, 1985: 13).

The excavation occurred in the summer of 1979. During the course of the project it was determined that the wreck was that of a waterschip. At least 10 wrecks of this type have been found in the IJsselmeer polders (Reinders, 1985: 27).

## CHAPTER III

## DESCRIPTION OF THE WRECK

The wreck was lying upright in mud, somewhat tilted to port and pitched slightly forward. As seen in Fig. 2, the forward end of the keelplank was approximately 24 cm. deeper in the former seabed than its stern end. The list to port helped preserve that side through the eighth strake amidships, while the starboard side was preserved only through the sixth strake.

The greater part of the hull was structurally intact. The framing and the planking were still fastened to each other and, except for distortion, largely undamaged. However, parts of the ends of the wreck were missing. At some point in time, the stem had become detached from the vessel and was found during the excavation a few meters from the wreck. The sternpost was still attached to the keelplank but its upper section had decayed away. The planks near the ends were splayed outward and the higher strake ends had lost as much as a couple of meters due to decomposition. The sheer strake and wale were missing along both sides of the wreck, leaving only traces on the port side amidships.

As seen in Fig. 3, there were three decks: a forward deck, a stern deck and a deck overlying the fishwell

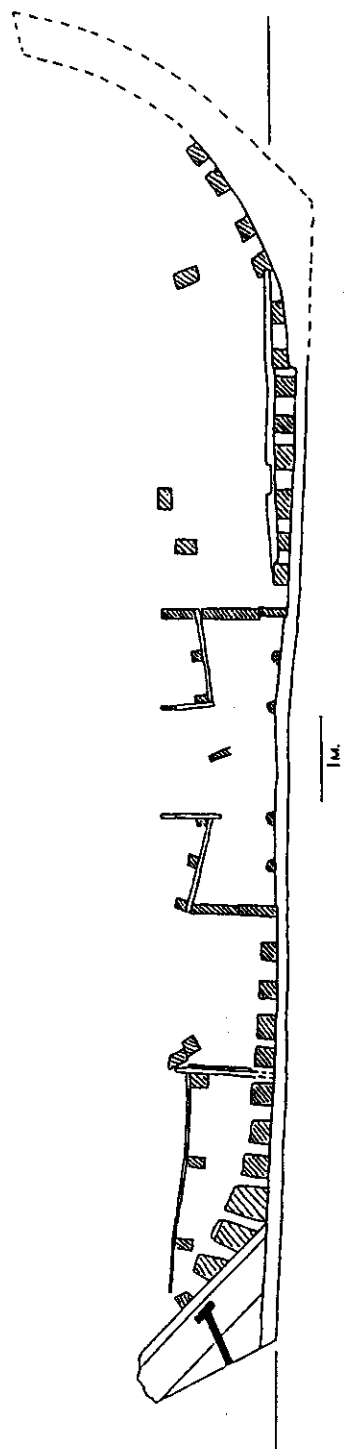

Figure 2. Profile of the wreck showing the longitudinal distortion of the vessel (after a drawing by RIJP).



Figure 3. Stereophotograph of the wreck with the overburden removed (courtesy of RIJP).

amidships. All three decks had collapsed into the vessel, with the forward and stern decks exhibiting the most damage. The stern deck, while missing its extremities and lying loose in the wreck, was structurally intact with the decking still attached to the deck beams. The forward deck survived only on the port side. Its starboard side had largely vanished due to the list to port which, by raising the starboard side higher, kept it exposed to the elements for a longer period of time.

Aside from a thin bulkhead on the fishwell deck, no remnants of the vessel's cabin were found. The rudder and tiller were also missing, as was almost all of the mast and rigging.

According to the excavators, all the vessel's timbers and wooden fastenings were of oak, species unidentified.

While the wreck was excavated from the decks down, the following description is presented in the reverse order, in the supposed construction sequence of the vessel.

### The Keelplank

The ship was set on a central timber, which being wider than it was deep at all points along its length, can be called a keelplank (McGrail, 1978: 113). As seen in Fig. 2, the keelplank had become distorted in profile due to

the pressure of the slowly disassembling hull against the mud.

The keelplank was 12.56 m. long, with a thickness of 13 cm. at its forward end and 11 cm. at its aft end. The width increased from 14 cm. at the forward end to 17.2 cm. at 3.1 m. aft of the forward end, then decreased gradually over the next 5.28 m., and then more rapidly to 10 cm. at the foot of the post.

The keelplank had a 1.5-cm.-deep rabbet along either side beginning 1.33 m. forward of the aft end. The rabbet continued forward for 11.04 m. where it met the stem (see Figs 4, 5).

Under the keelplank, a partial shoe was attached with iron nails. This began at the stern end and ran forward for 6 meters. The shoe was 8 cm. thick at its aft end and 4 cm. thick on its forward end.

### The Stem

The stem (Figs 4, 5), found lying near the wreck, was replaced in its original position by the excavators. Most of it was extant, but part of its after face had decayed away.

The stem had been attached to the forward end of the keelplank by means of a horizontal scarf that overlapped the keelplank's upper face. The keelplank was not



Figure 4. The stem (courtesy of RIJP).

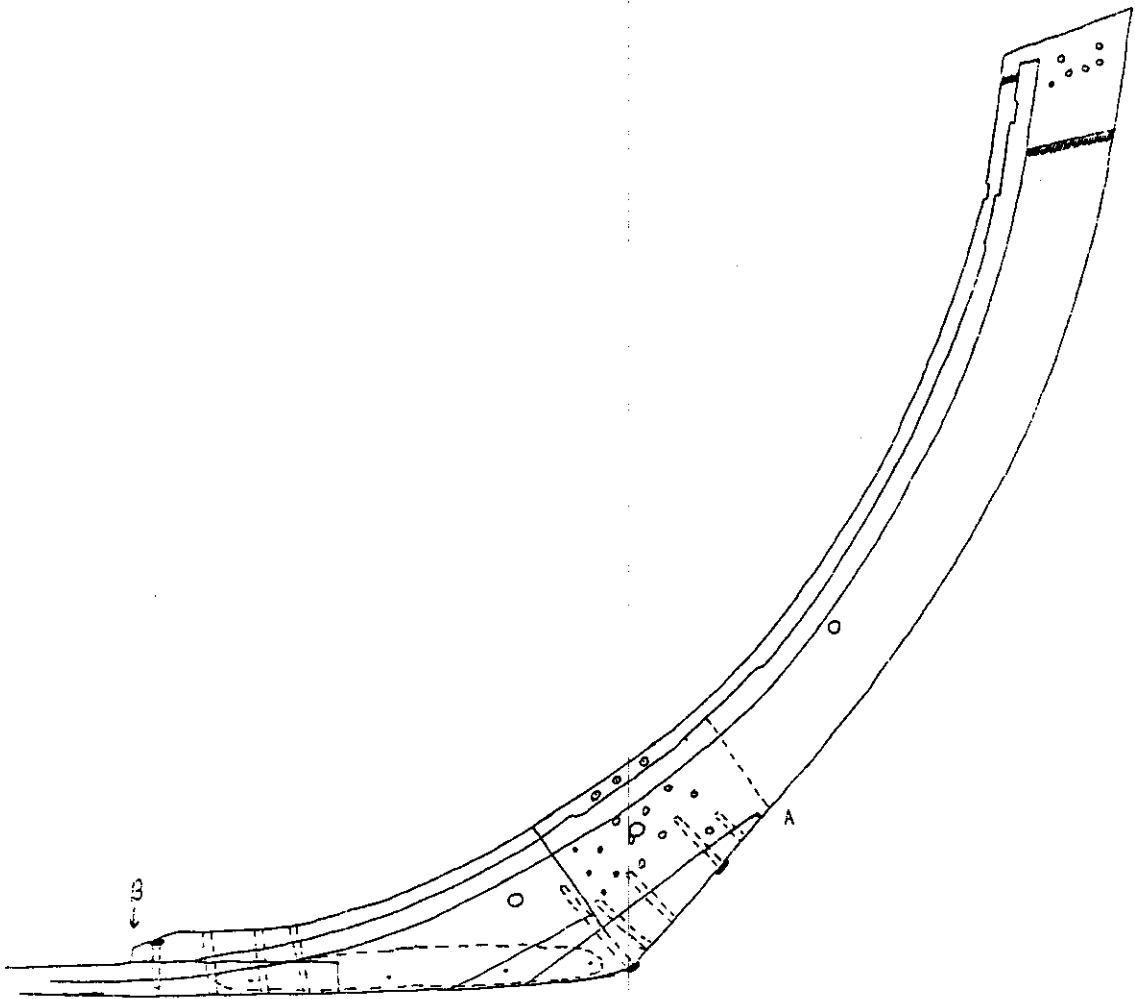

Figure 5. Drawing of the stem with joints, fastenings and other details shown (not to scale; after a drawing by RIJP).

rabbeted to accept the stem. Originally, the scarf had been fastened by 3 treenails and 1 iron spike, all of which were near the end of the stem's foot.

The height of the stem was 3.9 m. It was molded 54.5 cm. at the top and 44 cm. midway. It was sided 22 cm. on its entire after face. The forward face, however, was bearded off. At the top, it was sided 22 cm., tapering to 12 cm. at point A in Fig. 5. From there it tapered to 7 cm. at the heel of the stem. From the heel, the stem became wider along the bottom, until it met the keelplank, where it had approximately the same dimension as the keelplank's forward end.

The stem was composed of four parts, a lower stem, an upper stem, a filler piece and a small cutwater. The upper and lower stems were joined by a vertical scarf. The scarf was fastened at the lower end by 7 nails, although only 5 are shown in Fig. 5, and in the middle by 11 treenails, each 3 cm. in diameter. It is not known whether there were nails at the upper edge of the joint. Three of the treenails were located between the rabbet and the after face of the stem. The filler was fastened to the forward face of the lower stem piece. Its fastenings were not recorded. The cutwater was fastened to the filler and the upper stem with 3 treenails and 2 iron spikes. The upper spike was 28 cm. long and 2.5 cm.

square, with a head 7.5 cm. in diameter. The lower spike was 49.5 cm. long and had the same diameter as the head of the upper spike. The shaft of this lower spike was 2.5 cm. square in section and had flattened edges. It had a tapered point on which four grooves were positioned on the shaft edges, giving the point a barbed effect.

The treenails in the stem's forward face were, starting with the uppermost one, 14, 27 and 28 cm. in length. The diameter of the uppermost treenail was 2 cm.; the diameter of the other two, 3 cm.

The rabbet of the keelplank continued onto the stem. It was 5 cm. deep and was located 5 to 6 cm. from the stem's after face. Part of the rabbet was missing where the stem had decayed. The after edge of the rabbet exhibited joggles for the plank ends.

There were three holes 5 cm. in diameter bored through the stem from side to side at 26, 54 and 135 cm. above the keelplank. In addition to these, there were five more holes 10 to 16 cm. from the top of the stem (Fig. 6). Near these holes was one large nail.

Two grooves cut into the stem can be seen in Fig. 6. One was a notch 6 cm. high on the after face, located 319 cm. from the bottom. The other was on the stem's port face; it was cut at 340 cm. to 347 cm. above the keelplank.

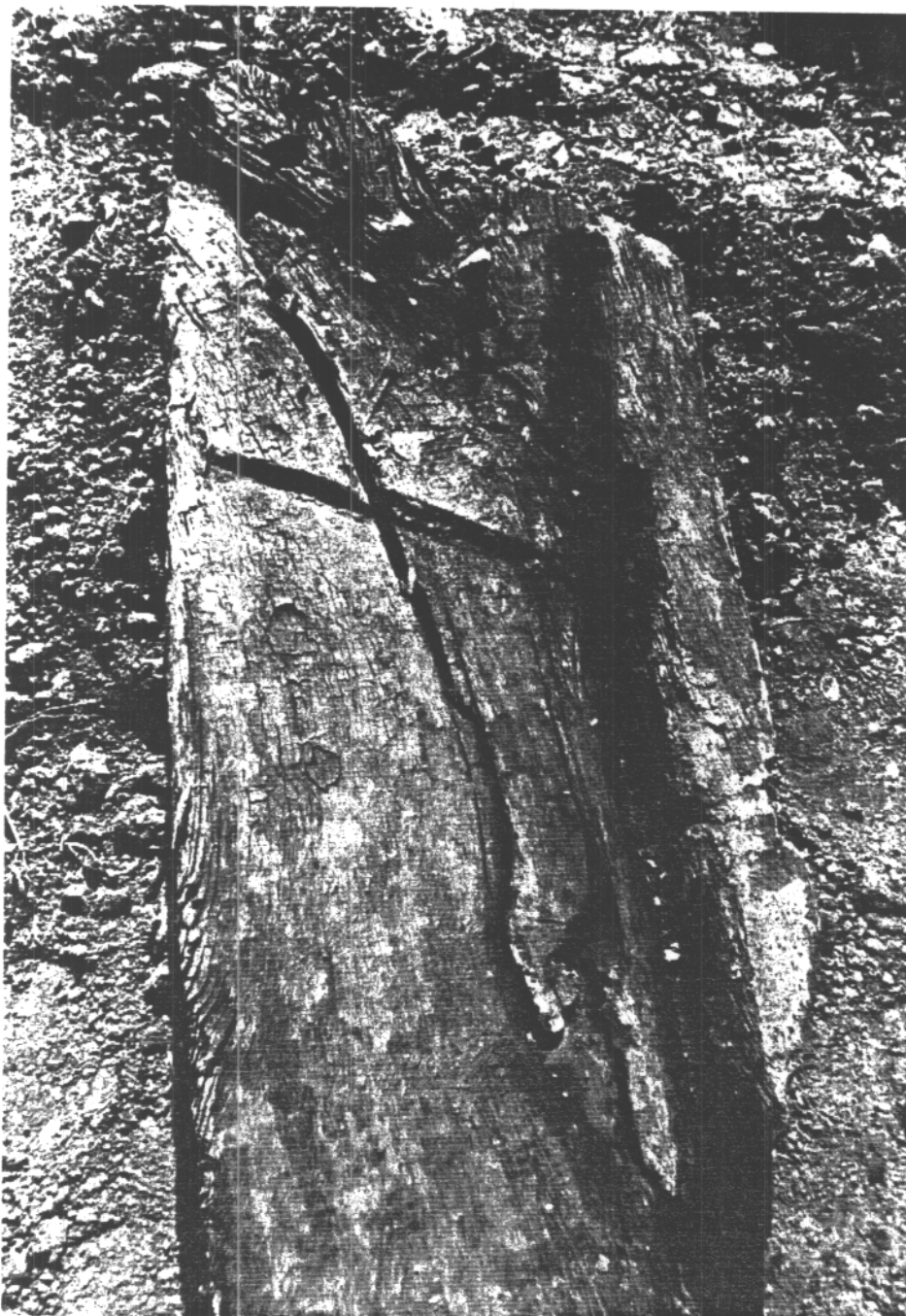

Figure 6. Detail of the stem top. Note in particular the series of holes (courtesy of RIJP).

One other feature on the stem was a pair of horizontal "stabilizers" located along the bottom on either side of the stem. They were 149 cm. in length and 15 cm. in height. Their breadths were not recorded. These timbers were each fastened onto the stem with at least 4 nails.

### The Sternpost

The details of the sternpost are illustrated in Fig. 2. The post comprised two members, both of which rested on the keelplank. Their fastenings to each other and to the keelplank were not recorded. The primary component was a straight timber standing at an angle of 41 degrees to the keelplank. It was 65 cm. long along its bottom, 138 cm. long on its surviving after face and 181 cm. long on its surviving forward face. Aft of this piece, the second component was positioned. This was a triangular timber which supported the forward component and also filled the angled space between the forward timber and the keelplank.

The preserved vertical height of the post was 149 cm., and its overall molded dimension along the keelplank was 151 cm. The post was sided 20 cm. on the forward face and 8 cm. on the after face. The rabbet was approximately 4 cm. deep with its after edge 12 cm. from the post's forward face and its forward edge flush with

the forward edge of the post. The rabbet was joggled to receive the hood ends, but unfortunately the positions of the joggles were not recorded.

There was also a gudgeon attached to the post 32 cm. above the keelplank.

### Planking

As previously mentioned, the port planking survived to the eighth strake, with only fragments of the ninth strake remaining. To starboard, the hull survived through the sixth strake with fragments of the seventh remaining. Of the fragmentary strakes, nothing was recorded. The ends of the planking were decayed above strake 2 in the bow and above strake 3 in the stern (Figs 7, 8).

The planks were clinker-built throughout the hull, and all were laid stern first. The landings were 6 to 10 cm. wide and were fastened with double-clenched iron nails every 10 to 14 cm. The dimensions of the nails were not recorded.

Planking thickness deviated throughout the hull and was independent of location in the hull. The thickness of the planks varied from 2.5 cm. to 4.5 cm., with a mean thickness of 3 cm.



Figure 7. A view of the wreck from the bow (courtesy of RIJP).

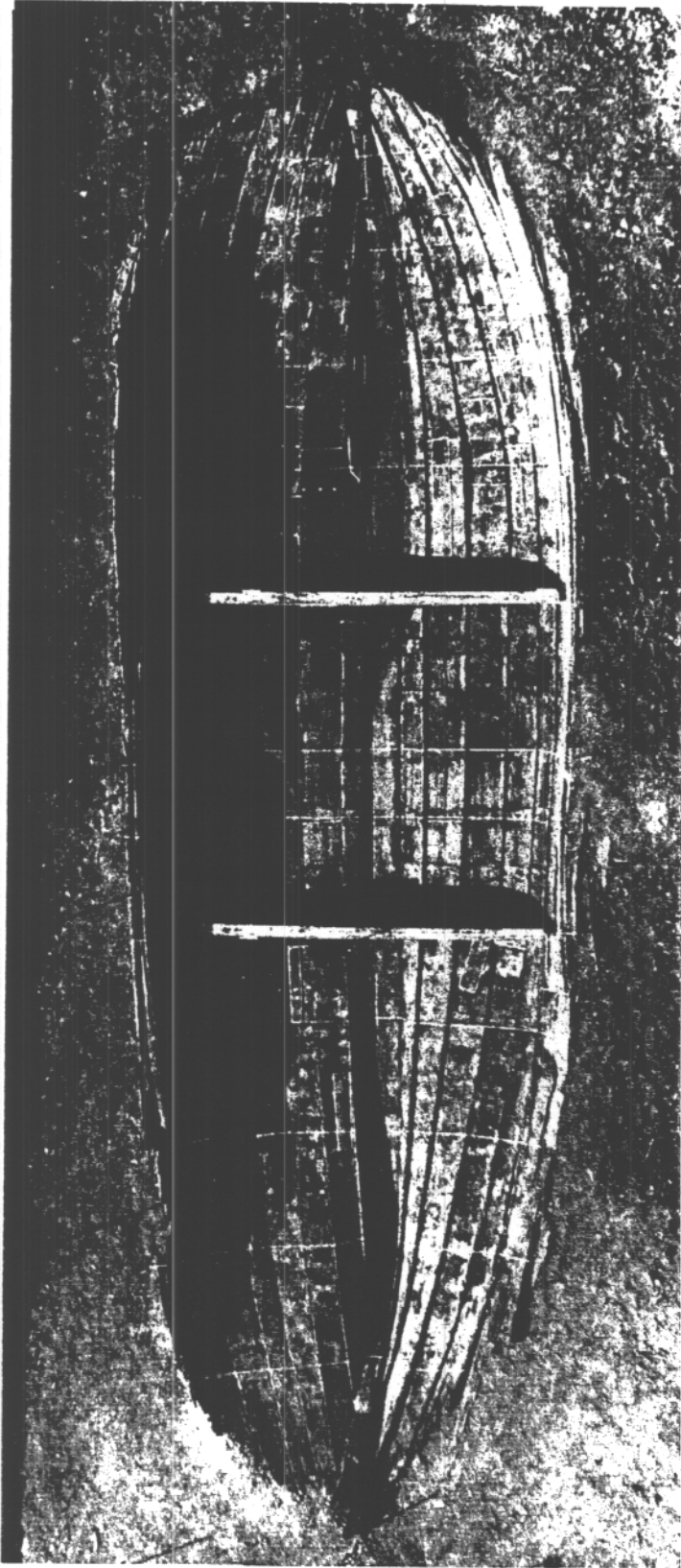

Figure 8. Stereophotograph of the wreck excavated to the planking (courtesy of RIJP).

Planking width depended on the area within the vessel. In general, the planks were widest amidships, while they tended to narrow towards the ends. Reconstructed planking widths will be graphically presented in the following chapter.

The garboards sat in the rabbet and were fastened to the keelplank and posts with iron nails. They were angled steeply to the keelplank towards the vessel's ends, while amidships the garboards were nearly horizontal.

In general, the upper edge of each strake was beveled on the outside to accommodate the overlapping strake. Some lower strakes, such as those overlapping the garboard or in the tuck, were bevelled on their lower edge to fit the strake beneath.

There was no caulking between the faces of the landings. Instead, the seams were sealed on the inside with packed moss under a half-round lath held in place by iron sintels. The spacing of the sintels, as well as their size and shape, was not recorded in the excavation notes. However, a shape common to waterschepen (Fig. 9) was presented in an RIJP work document (Vlierman and van Dijk, 1980: fig. 1).

Each strake consisted of 2 to 4 planks, with the upper strakes having the most components. The planks were

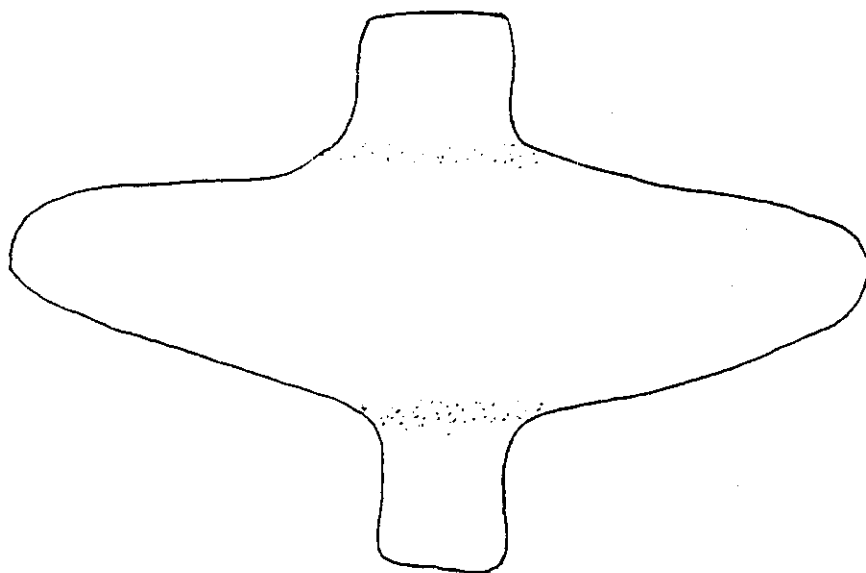

Figure 9. Sketch of the type of sintel commonly found on waterschepen (not to scale; after Vlierman and van Dijk, 1980: fig. 1).

Joined with vertical scarfs to form the strakes. The scarfs were caulked with moss between their faces and were fastened on their ends with double-clenched iron nails spaced 7.5 cm. apart. The scarfs were 45 cm. long on average, with the longest at 50 cm. and the shortest at 27 cm.

On either side of the wreck, the planking in the fishwell, located between the bulkheads (Fig. 2), was pierced with many holes 1 cm. in diameter. These holes were spaced 4 cm. apart and arranged in a diamond pattern (Fig. 10). On either side, the pattern of holes extended from the keelplank to a row of treenails near the top of the sixth strake (Fig. 11). The planking scarfs in the fishwell were not pierced by holes nor were the landings. There was no sinteling along the landings in the fishwell. It is not known whether the scarfs were also left uncaulked. The caulking method of the joints between the planking and the bulkheads was also not recorded.

#### Planking Details

The planking details presented in Table 1 were taken from photographs, stereophotographs and stereographic plottings. Also used were drawings made by the excavators of various sections of the wreck. Since



Figure 10. The planking to starboard inside the fishwell (courtesy of RIJP).



Figure 11. The planking to port in the fishwell. Note the row of thin treenails for the attachment of the waterway (courtesy of RIJP).

Table 1. Strake details.

		# of planks	Plank lengths (from aft) in m.	Scarf lengths, in cm.
Garboards	Port	2	7.52, 5.40	40
	Starboard	2	7.94, 4.98	44
Strake 2	Port	3	5.92, 4.64, 4.34	45, 46
	Starboard	3	5.94, 4.66, 4.32	44, 44
Strake 3	Port	4	<u>5.21</u> , 5.46, 1.48, <u>3.70</u>	44, 45, 46
	Starboard	4	<u>5.22</u> , 5.47, 1.44, <u>4.16</u>	45, 45, 46
Strake 4	Port	3	5.62, 5.54, 4.93	46, 45
	Starboard	3	5.56, 5.95, 4.78	44, 44
Strake 5	Port	2	4.46, 10.84	44
	Starboard	3	4.48, 7.66, 3.64	46, 44
Strake 6	Port	4	<u>5.36</u> , 5.86, 2.12, <u>2.94</u>	44.5, 47.5, 44
	Starboard	4	4.74, 5.94, 2.26, <u>2.80</u>	46, 44.5, 44
Strake 7	Port	4	<u>3.38</u> , 4.86, 4.09, <u>3.72</u>	46, 44.5, 49
	Starboard	Unk.	Only fragments	Unk.
Strake 8	Port	4	<u>3.31</u> , 5.24, 2.30, <u>3.90</u>	45, 27, 50
	Starboard		No longer extant	
Strake 9	Port	Unk.	Only fragments	Unk.
	Starboard		No longer extant	

Note: underlined values are surviving lengths.

variations in the thickness of the planking were random, these figures are not introduced here and are only presented graphically in the reconstructed sectional drawings in the following chapter.

While items such as scarf and plank lengths were not included in the excavation notes, the scarf lengths were indicated in both the stereographic planking view and plotting. It is assumed that the outside, and therefore invisible, extremities of the scarfs were marked in relation to the clenched nails of the scarf ends. In turn, these scarf lengths were used to determine the plank lengths which otherwise would have been unavailable.

#### Repairs to the hull

There were 16 surviving repairs in the planking. As determined by the excavators, these repairs, with the exception of one, were from the time of construction and not from subsequent maintenance procedures. The repairs were patches, or planks, 2 cm. thick overlaying cracks or similarly damaged areas. The repair planks had widths ranging from 4 to 21 cm. The planks were laid over a caulking of moss and fastened to the planking with iron nails. While some of the patches were cut to fit between the framing, indicating their addition after the

vessel was framed out, most had the frames cut precisely to fit over the patches, indicating that they were added to the hull before framing.

The single, aforementioned exception to this kind of repair was in the bow where a resin, identified as harpuis, was spread out on the two seams along a strake. This was apparently not a constructional repair but was a later repair to stop these seams from leaking.

### Repair Details

The figures presented here for the sizes and locations of the patches were determined solely from the stereographic plotting. The patches are illustrated in the following chapter in the reconstructed planking diagram (see p. 109).

The port garboard had two repairs, both on the second, i.e., forwardmost, plank. The aftermost repair was 13.8 cm. wide and ran from 127 to 178 cm. forward of the forward bulkhead. The second was 11.8 cm. wide and ran from 228 to 271 cm. forward of the same bulkhead. The starboard garboard had no repairs.

The second port strake had one repair, located on the first plank. It was 14 cm. wide, began 2.7 m. aft of the forward end of the first plank and ran aft 77 cm. The patch was 3 cm. above the seam with the garboard.

Like its port counterpart, the second starboard strake had one repair, but here it was on the second plank. The repair began 3 cm. forward of the scarf of the second and third planks and ran aft over this scarf onto the second plank for 1.45 m. It was 21 cm. wide and was located 8 cm. above the seam with the garboard.

The third port strake had one repair, which was located at the forward end of the first plank and extended aft 78 cm. The patch was 12 cm. wide and was located 12 cm. above the seam.

The surviving part of the third starboard strake had one repair 20 cm. wide beginning at the scarf of the first and second planks and extending aft 60 cm. The patch was not parallel to the seam below but was 4 cm. above the seam at its forward end and 16 cm. above it at the patch's after end.

The fourth port strake had one repair located on the third plank, starting 3.04 m. forward of the second scarf. It was 20 cm. wide, 44 cm. long and flush with the top edge of the strake. It is not known whether the patch overlaid the nails of the overlap or if the nails were driven through the patch and clenched over it.

The fourth starboard strake had three repairs. The first began at the scarf joining the second and third planks and extended aft 88 cm. It was 11 cm. wide and

ran 8 cm. above the seam. The second began 50 cm. forward of the same scarf but ran forward 71 cm. with a width of 8 cm. The patch was 6 cm. above the seam at its after end and 5 cm. above the seam at its forward end. The third repair was 2.7 m. forward of the joint of the second and third planks, and extended forward 24 cm. It was 18 cm. wide and ran 2 cm. above the seam.

The fifth port strake had one repair located 1.22 m. to 1.98 m. forward of the forward bulkhead. It was 9 cm. wide and ran 3 cm. above the seam.

The corresponding strake on starboard also had one repair, which began 4.58 m. forward of the forward bulkhead and extended 76 cm. towards the bow. The patch had a width of 10 cm. and was 2 cm. above the seam at its after end while touching the seam at its forward end.

The sixth port strake had one patch at the forward end of the second plank. The repair, located 4 cm. above the seam, ran aft 72 cm. and was 8 cm. wide.

There were two repairs in the sixth starboard strake. The first was located at the forward end of the second plank and extended aft 1.24 m. The patch was 4 cm. wide and placed above the seam 6 cm. aft and 3 cm. forward. The second repair began at the forward end of the third plank and ran aft 1.78 m., almost the entire length of

the plank. The patch was 3 cm. above the seam aft and 7 cm. forward. Its width varied from 8 to 10 cm.

The seventh port strake had no repairs. The seventh starboard strake survived only in fragments, about which no information was recorded.

The eighth port strake had no repairs. The eighth starboard strake was no longer extant.

The ninth port strake survived only as a small fragment and no information was recorded about it. The ninth starboard strake was no longer extant.

### The Framing

As seen in Fig. 12, the framing can be divided on structural grounds into three groups: those aft of the fishwell; those in the fishwell, including the bulkheads; and those forward of the fishwell.

Using the middle bulkhead as the midship station, the frames were assigned numbers in the after half of the vessel and letters in the forward half.

All of the framing members were attached to the strakes with two treenails per plank. The treenails were all 3 cm. in diameter and were driven from the outside to the inner faces of the frames. As Fig. 13 illustrates, the treenails were wedged on the outside. The edges of the frame members were chamfered, and their inboard faces

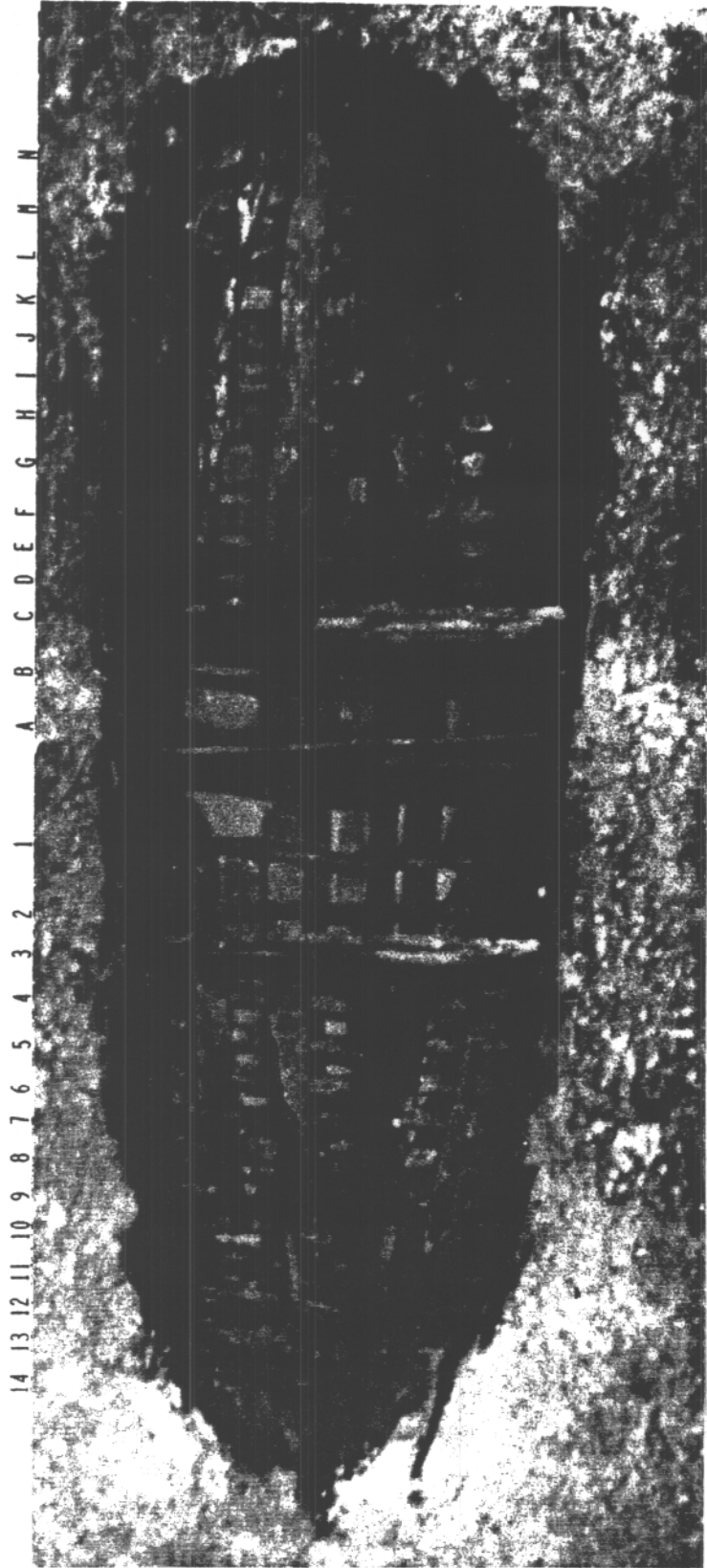

Figure 12. Stereophotograph of the wreck excavated to the framing (courtesy of RIJP).

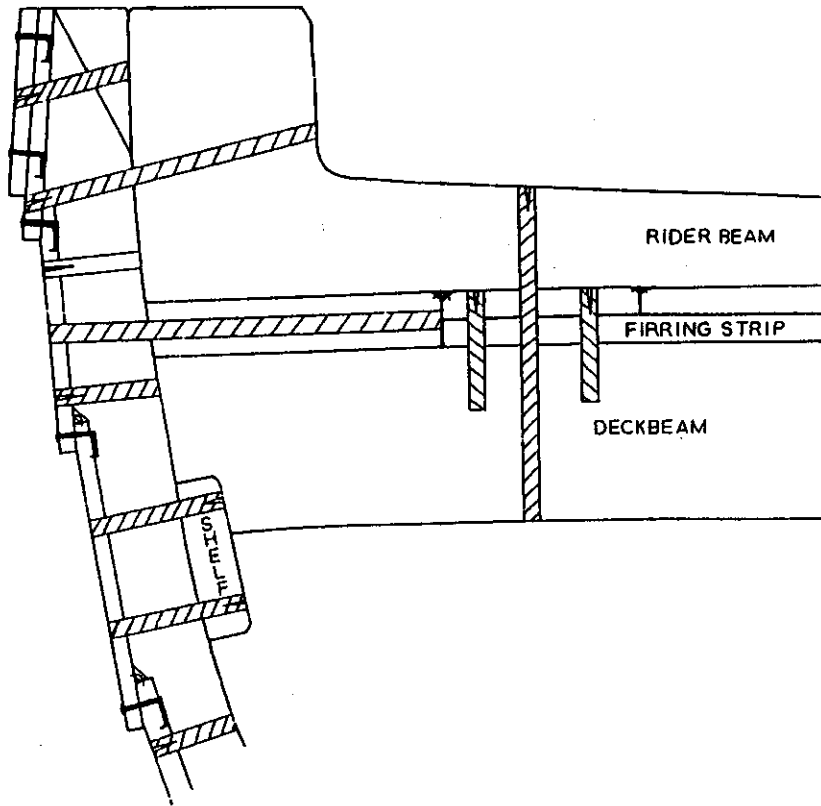

Figure 13. Detail of the fastenings. (Not to scale).

were smooth, while their molded faces were irregular. The frames were set along the keelplank approximately every 40 to 45 cm., center to center. None were fastened to the keelplank or posts, with the exception of the forward and after bulkheads.

There were no limber holes in any of the frames.

### Forward Frames

The frames forward of the fishwell consisted of a floor timber and two futtocks. The floor timbers extended from bilge to bilge (Figs 14, 15), with futtocks mounted on top of either end. The scarfs joining the framing timbers were fastened with 1 or 2 treenails. The futtocks were slightly curved and joggled to fit the lapstrake planking. The joggles were cut imprecisely in many cases, leaving gaps between the frames and planking at the landings.

Of the eleven surviving forward frames, six rested on the keelplank and the remainder on the stem. In general, the frames were sided almost twice what they were molded, e.g., 25 x 15 cm. In some cases, such as frames D and J, the futtocks were sided greater than the floor timber to which they were joined.

The frames on the stem were canted so that each was set somewhat perpendicular to the stem. None of the

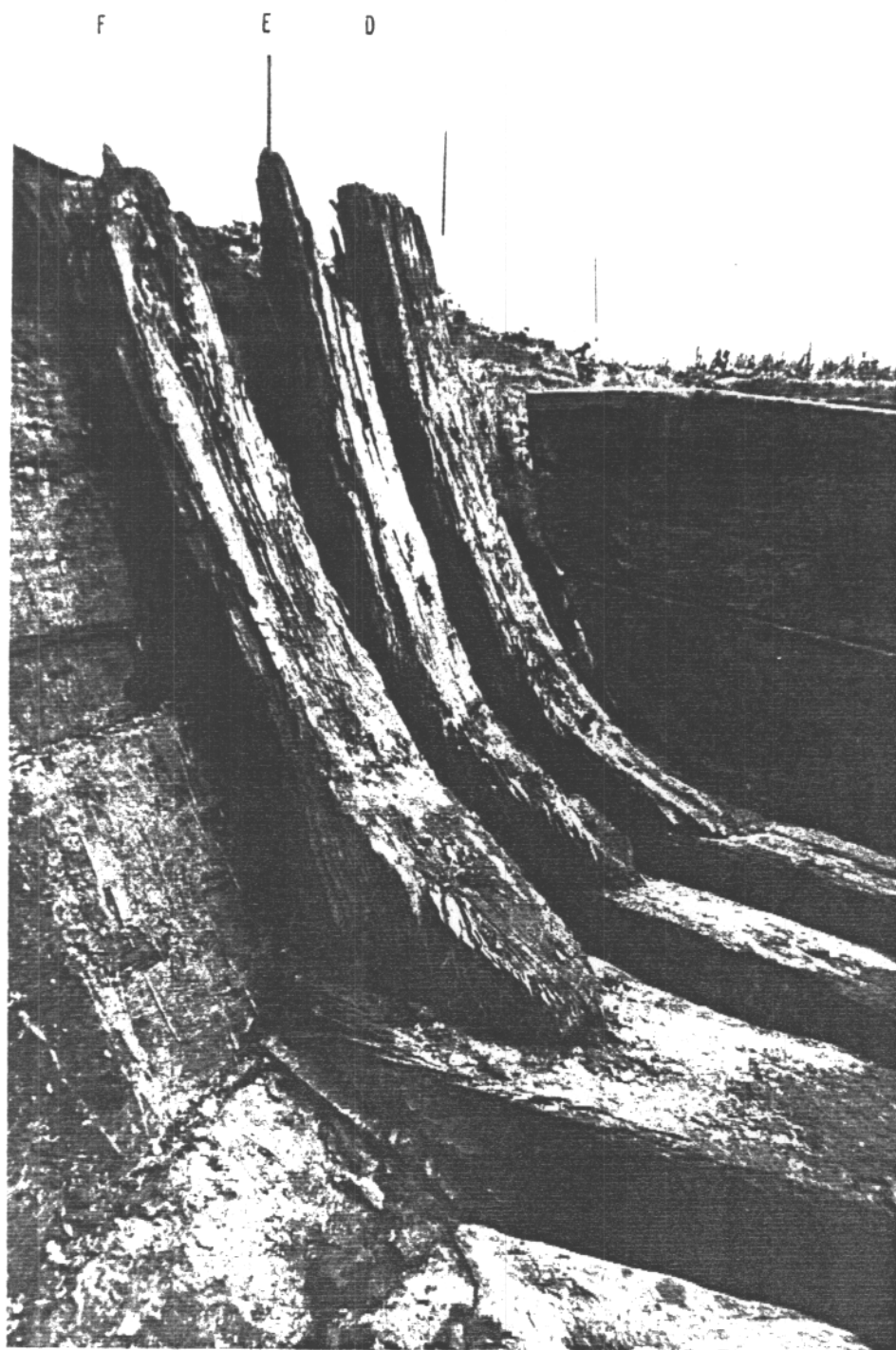

Figure 14. The remaining futtocks to starboard in the bow. Note the greater sided dimensions of the floor timbers (courtesy of RIJP).



Figure 15. The scarfs of futtocks to floor timbers to starboard in the bow (courtesy of RIJP).

surviving frames on the stem were breast hooks.

The scarfs joining futtocks to floor timbers were located at the turn of the bilge in most cases (Figs 16, 17). Exceptions to this pattern were: frames J and L, where the port scarfs were located between the bilge and the keelplank; frames G and H, whose starboard scarfs were also located between the bilge and keelplank; and frame E, which was scarfed to port at the level of the fifth strake.

One other irregularity concerning the forward frames was a pump notch found in the after face of frame I (Fig. 18). The opposite frame face, namely the forward face of frame H, was not notched.

A few of the frames that survived up to their tops, such as frame F, displayed mitered ends to accept a sheer clamp (Fig. 19).

Only two drawings of floor timbers were made by the excavators. These displayed the wood grain patterns at various places along the timbers' length (Fig. 20).

### Stern Frames

The frames in the stern also consisted of a floor timber and two futtocks, but the floor timbers here were shorter than those in the bow. In the stern, they were in the form of crooks carved to fit in the acutely angled area

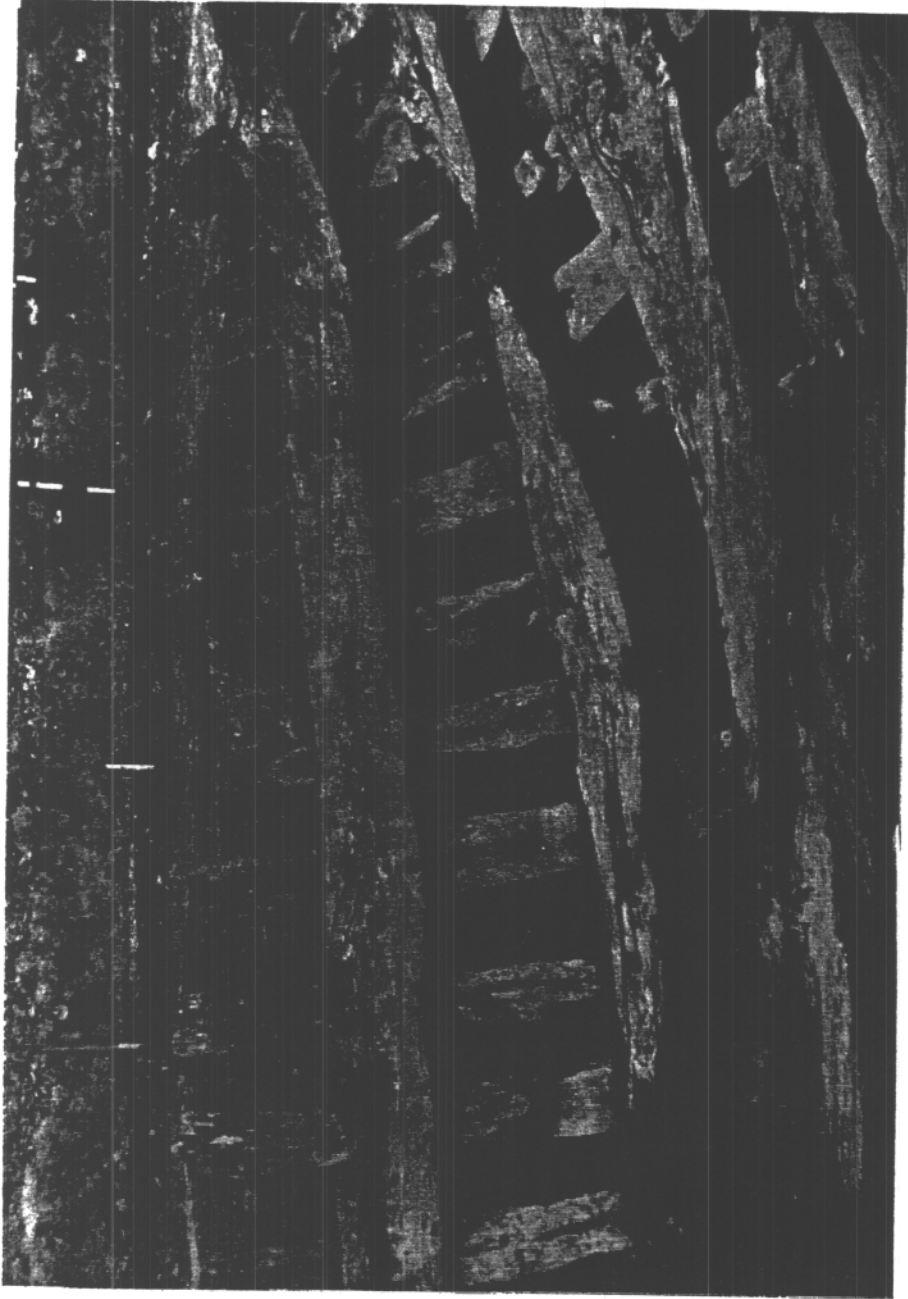

Figure 16. The stringers to port in the bow (courtesy of RIJP).

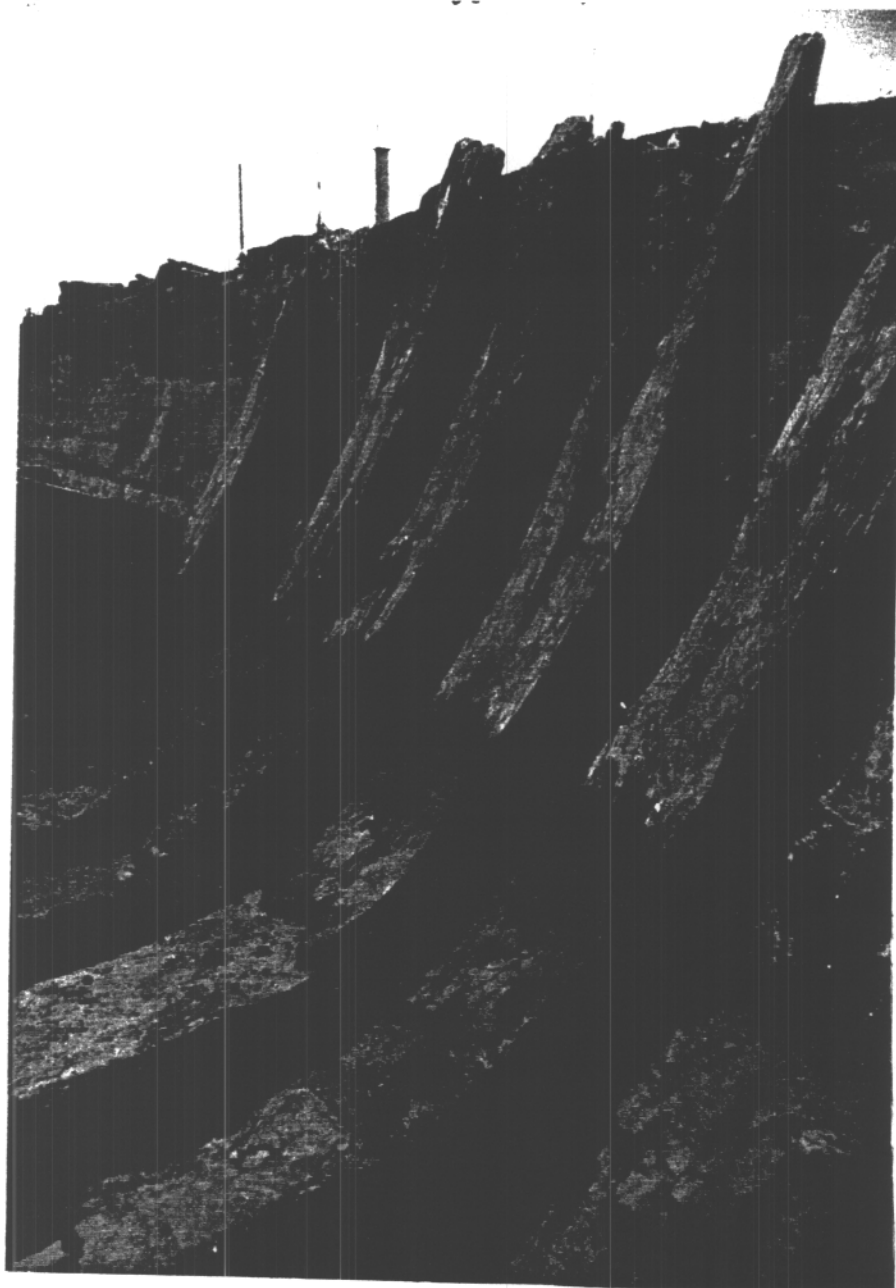

Figure 17. The scarfs of futtocks and floor timbers to port. Note the treenails and the discoloration where the bilge stringer sat prior to removal (courtesy of RIJP).

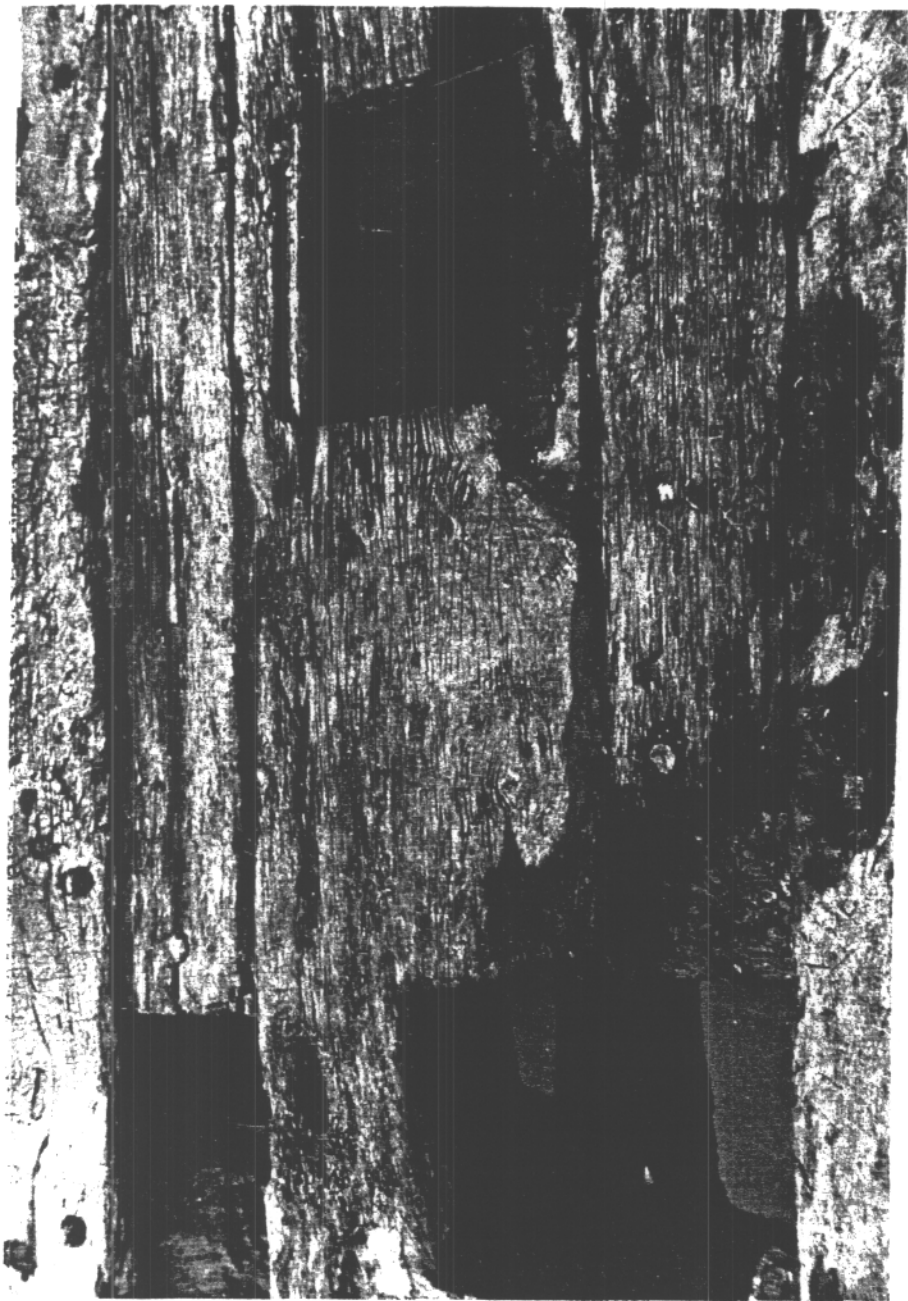

Figure 18. The mast socket and the pump notch. Note the notch in frame I (extreme left) and the unnotched face of frame H to its right (courtesy of RIJP).



Figure 19. A view from the bow. Note the frame tops on the right displaying the mitered ends for the sheer clamp (courtesy of RIJP).

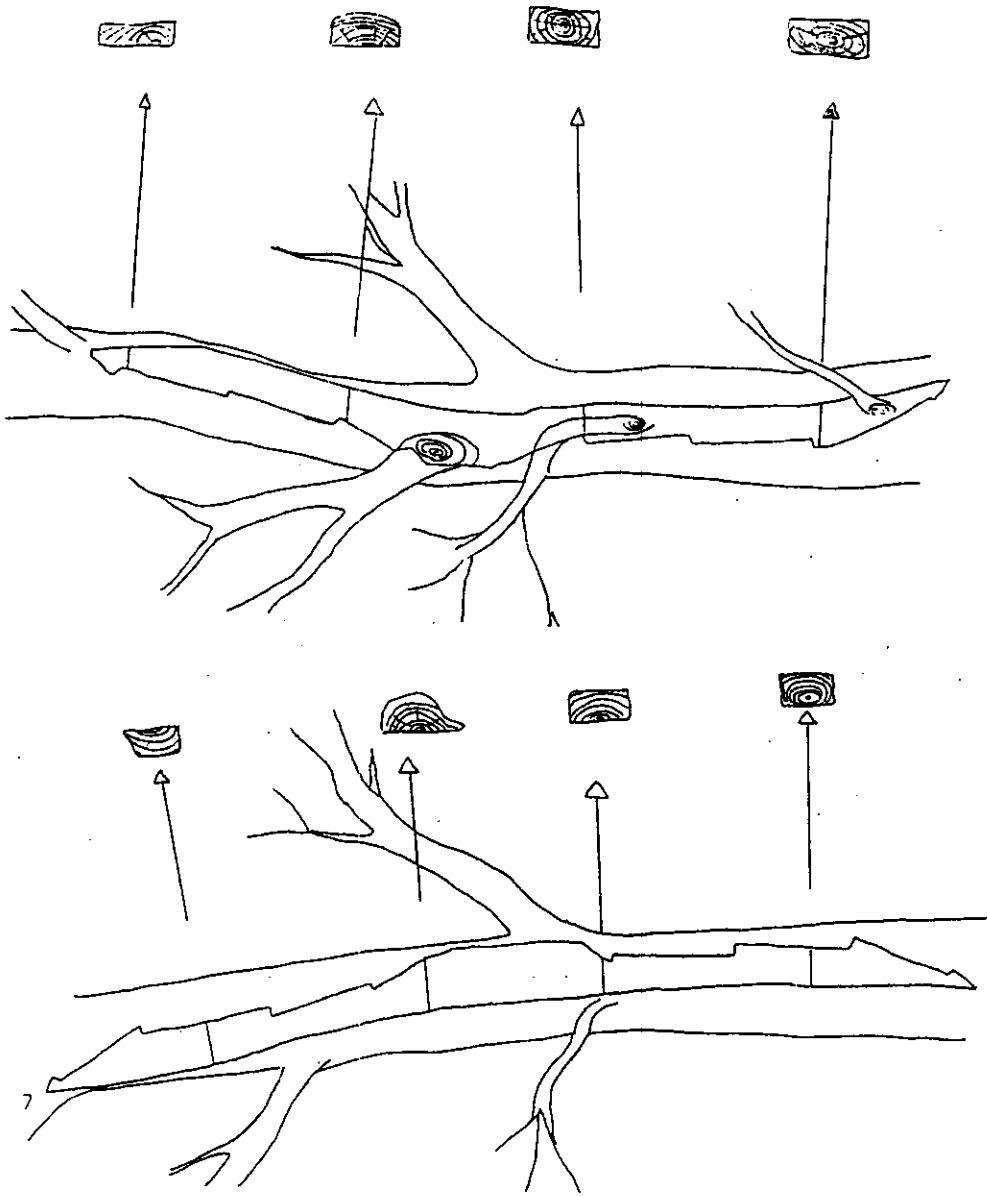

Figure 20. Sketches of two frames from the bow and the grain patterns (after excavation sketches by K. Vlierman).

between the first few strakes on either side of the keelplank. As seen in Fig. 21, this carving is noticeable in the pattern of the wood grain. Additionally, the upper faces of these floor timbers were deeply notched along the centerline mirroring the angle between the strakes. Some, such as frame 10 in Fig. 22, were so deeply carved as to suggest the undermining the timber's strength.

Each floor timber had one long arm. As seen in Fig. 23, the farther aft a frame was placed, the nearer the scarf at the end of the shorter arm was to the centerline of the vessel, with frame 9 being the first to be scarfed directly in the center. Frame 4 had its port scarf at the seam of the second and third strakes and its starboard scarf at the turn of the bilge. In contrast, frame 5 had its port scarf at the turn of the bilge and its starboard scarf at the seam of the second and third strakes. This indicated that a pattern was intended by the builders. However, it was not rigidly followed, since the floor timbers with their long arms on port were frames 5,6,8,9, and 11, while those with their long arms on starboard were 4,7,10,12, and 13. Frame 14, located on the post, had equally long arms and was therefore a crutch.

Treenails visible in the photographs indicate that there was at least one frame missing aft of frame 14.

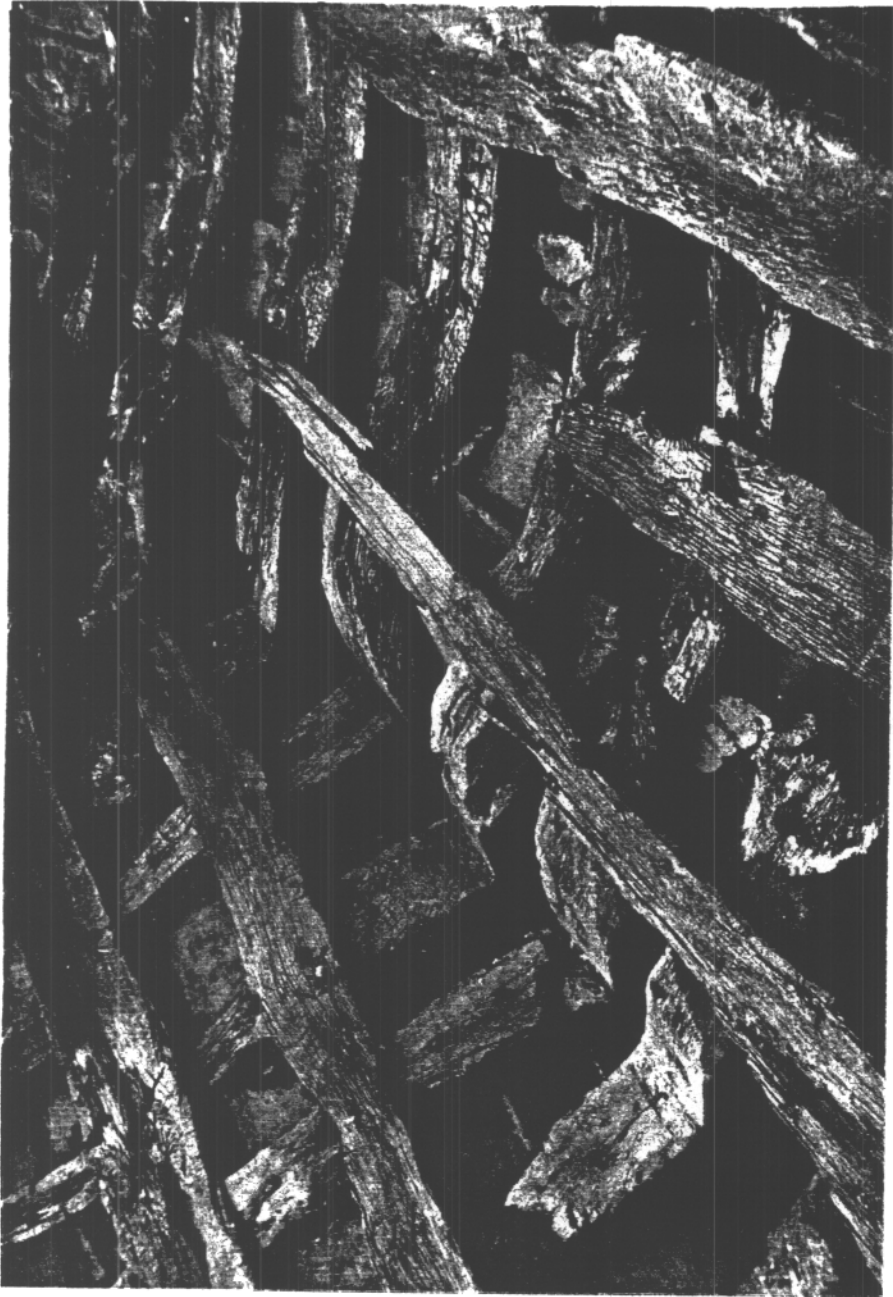

Figure 21. The frames in the stern. Note how the floor timbers have been carved over the keelplank mirroring the shape of the hull (courtesy of RIJP).

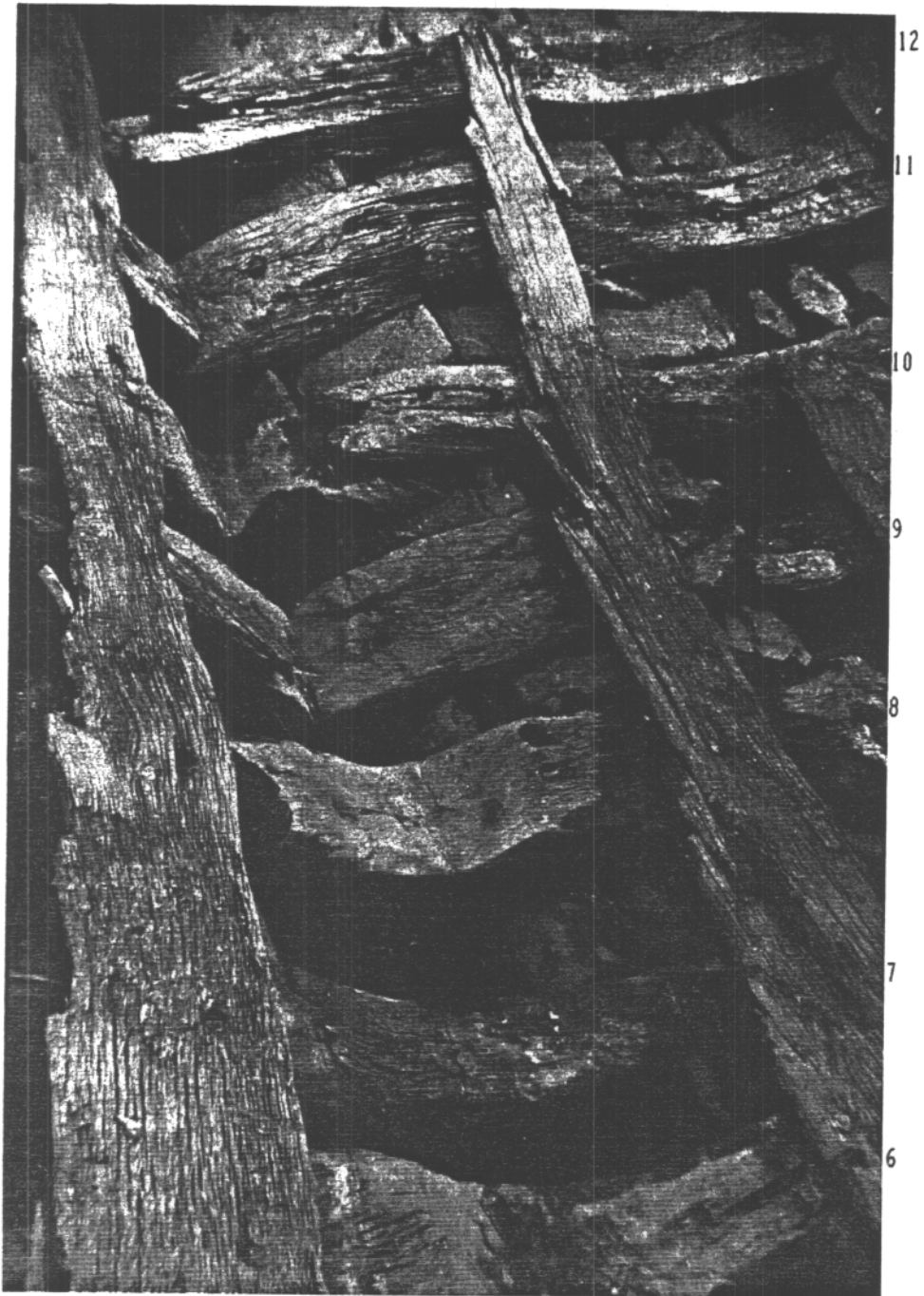

Figure 22. The stern floor timbers. Note in particular the deep notch in frame 10, third from the top (courtesy of RIJP).

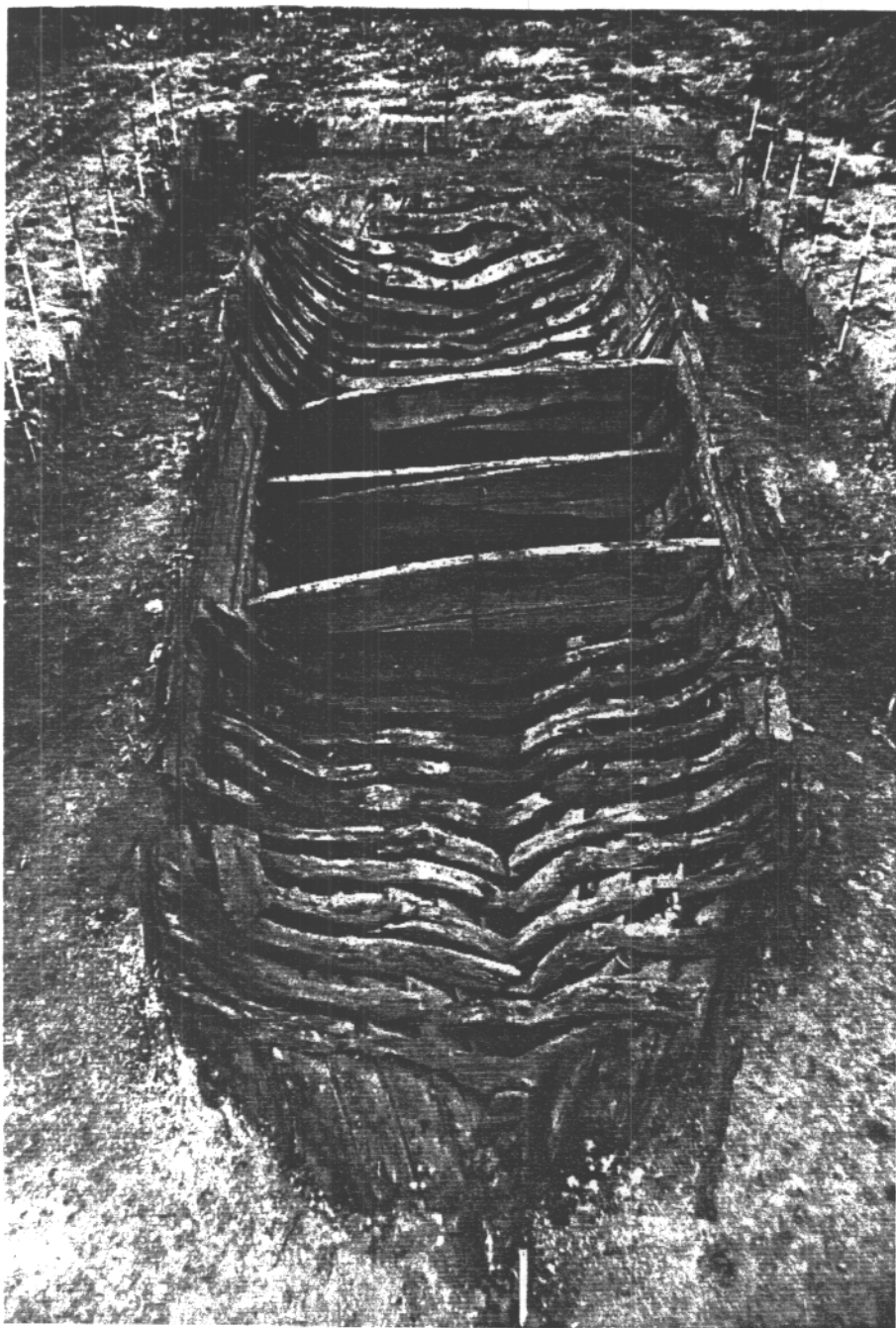

Figure 23. A view of the wreck from the stern with the decks removed (courtesy of RIJP).

One other detail of note concerning the stern frames was a notch on the after face of frame 7, in which was seated a supporting stanchion for the first stern-deck beam.

### Fishwell Frames

The framing in the fishwell included an after bulkhead; a middle bulkhead; a forward bulkhead; 2 light frames, 1 and 2, between the aft and middle bulkheads; and 2 light frames, A and B, between the middle and forward bulkheads.

The Light Frames. Frames 1, 2, A, and B were light, rounded timbers sided 15 cm. and molded 10 cm. The futtocks sat on top of the floor ends, but whether the scarfs were fastened was not recorded and is not apparent in the photographs. The futtocks reached to the underside of the fishwell deck near the top of the sixth strakes.

Frame 1 consisted of a floor timber with a futtock to port. The port end of the floor timber was scarfed to the futtock at the third strake, while the starboard end of the floor timber was preserved to the top of the fifth strake. One of the treenails fastening the frame to the

planking passed directly through the landing of the fourth and fifth starboard strakes.

Frame 2 consisted of a floor timber with a futtock on either side. The floor timber had one long arm to port which extended to the fourth strake (Fig. 24). The starboard arm extended to the top of the second strake.

Frame A was scarfed at the top of the fourth strake to port. The configuration of its starboard side is unknown.

Frame B was scarfed on the port side at the third strake. The top of this futtock, the only original end to survive among the fishwell frames, was notched to receive a deck beam. The frame's starboard configuration is not known.

The Bulkheads. The after fishwell bulkhead, designated frame 3, consisted of an upper and a lower piece. The bulkhead was 4.29 m. broad and 13.5 cm. thick. The two members were joined on edge with treenails and a single iron spike that ran from the upper face of the bulkhead through the center of the pieces down into the keelplank. This spike was 3 cm. square in section in its top half and round in section in its lower half. The bulkhead was fastened to each strake by two treenails and one iron nail, the lengths of which were not recorded.



Figure 24. Detail of the frames to port in the after half of the fishwell (courtesy of RIJP).

The middle fishwell bulkhead, frame 0, was no longer intact, thus causing the collapse of the deck. The bulkhead was 4.52 m. broad and 8.5 cm. thick. It was made of three pieces and had been fastened together with treenails only. The bulkhead had been fastened to the strakes with two treenails per strake. There were no iron fastenings.

The forward fishwell bulkhead, frame C, was 4.6 m. broad and 13 cm. thick. Like the after bulkhead, it was made of two pieces joined on edge with treenails with one long iron spike that ran from the upper edge into the keelplank. Unlike the spike in the after bulkhead, this one was 3 cm. square in section over its entire length. This bulkhead was also fastened to the strakes by two treenails and one iron nail per strake. The bulkhead's upper component was made from the full breadth of a tree with 70 rings from heart to sapwood.

### The Stringers

Lying over the frames were stringers (Fig. 12). The surviving forward stringers comprised the mast step, a port and starboard bottom stringer, a port and starboard bilge stringer, and the port shelf. In the stern, two bottom stringers, the bilge stringers and the port shelf

survived. There was no central stringer in the stern and there were no stringers in the fishwell.

All the stringers were fastened to the frames with treenails 3 cm. in diameter and, unlike the treenails fastening the frames to planking, were wedged from the inside.

### The Forward Stringers

The forward stringers began at the after edge of frame D. The area between the forward bulkhead and frame D was left open as a drain or gutter, as seen in Fig. 25. The mast step (Fig. 26) was placed directly over the centerline of the vessel. This timber was 3.54 m. long. Its width aft was 44 cm. and its width forward was 31 cm. In the middle, the step was 49 cm. wide and 11 cm. thick. From its mid-point, the step tapered in thickness towards either end. It was nailed on the ends and fastened to the floor timbers on which it rested with two treenails per floor timber.

There was a rectangular socket in the step for the mast foot. It was 7 cm. deep, 46 cm. long and 31 cm. wide. In addition, there were two grooves along either side of the mast socket (Fig. 18). Forward of the socket, over the notch in frame I, was a notch 46.5 cm. wide aft and 38 cm. wide forward. This was apparently for a pump.

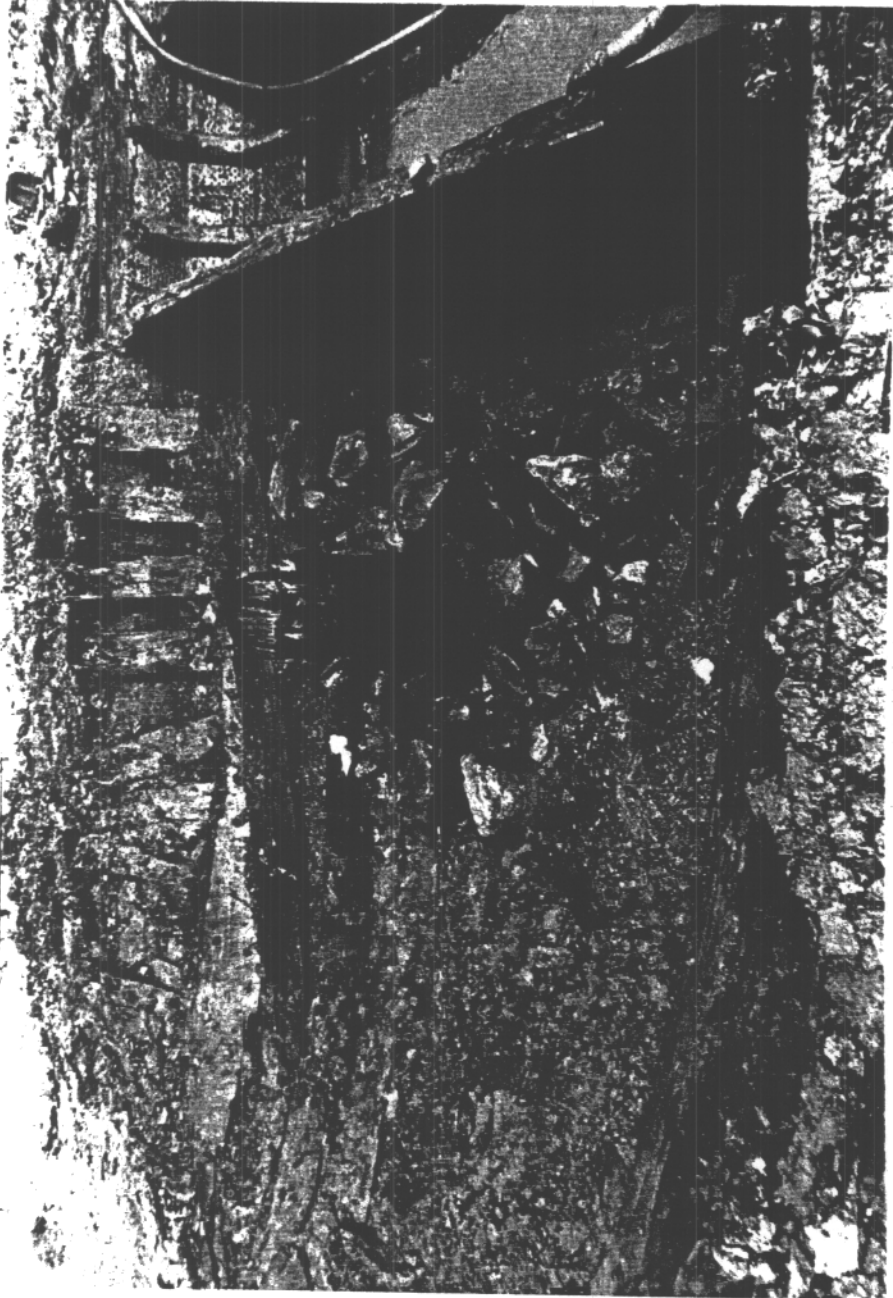

Figure 25. The forward section of the wreck before final cleaning. Note the open area between the forward bulkhead and the frame just forward of it (courtesy of RIJP).



Figure 26. The mast step, chocks and bottom stringers (courtesy of RIJP).

Along either side of the step was a chock 1.3 m. long, 26 cm. wide and as thick as the mast step. The chocks were nailed at both ends and treenailed to the floor timbers.

The outboard edges of the chocks touched the inboard edges of the bottom stringers. Both stringers were approximately 58 cm. wide and 7 cm. thick. The surviving lengths were 5.31 m. on the port side and 5.1 m. on the starboard side. The stringers were fastened to the floor timbers with three treenails per floor and two large nails at their after end near the gutter.

The bilge stringers were both approximately 38 cm. wide and 8 cm. thick. Their surviving port and starboard lengths were 5 m. and 2.34 m. respectively. They were fastened to the frames with two or three treenails per frame and laid over the scarfs of futtocks to floor timbers.

Nothing remained of the starboard shelf, while the port shelf was mostly intact. Although it was broken at frame L, the port shelf stretched from 4 cm. forward of the bulkhead to a few centimeters forward of frame N (Fig. 16). The shelf was 5.1 m. long and, like the other stringers, 38 cm. wide by 7 cm. thick. It was fastened to each frame by two or three treenails. The shelf was set at a height equal to the upper edge of the seventh

strake. Along its upper edge were two dovetail notches for deck beams. They were 7 cm. in depth, and located 68 to 87 cm. and 122 to 142 cm. forward of the fishwell.

### The Stern Stringers

The stern stringers (Fig. 27) began at frame 4. Although the port bilge stringer ran a little forward of this frame, an open space was left between frame 4 and the after bulkhead to serve as a drain, as in the bow. All of the stringers were 4.5 cm. thick except the shelf which was 5 cm. thick. The port and starboard bottom stringers were 3.46 m. and 3.66 m. long, respectively; the port and starboard bilge stringers were 2.86 m. long and 3.88 m. long. The port shelf was 40 cm. wide and 3.52 m. long. Like the forward port shelf, it had two notches for deck beams. These were located at 1.77 to 2 m. and 2.68 to 2.84 m. aft of the bulkhead. The shelf ran along the upper edge of the seventh strake and began approximately 4 cm. aft of the drain.

There was a ceiling lying loose over the area from frame 4 to aft of frame 7. The ceiling was 3 cm. thick and covered the spaces between all the stringers including the shelf. This area was part of the cabin.



Figure 27. The stringers in the stern as viewed from the port side with the ceiling removed. Note the space between the bulkhead and the first frame aft (courtesy of RIJP).

## The Decks

There were three decks on NZ421: the forward deck, the fishwell deck and the stern deck. The decks consisted of planking laid longitudinally over deck beams. The planking of the forward and fishwell decks was 5 cm. thick, while the decking of the stern deck was 4 cm. thick.

Each deck plank was fastened to each beam with two treenails 3 cm. in diameter. The decking seams were caulked with sinteling on the forward and fishwell decks, while the stern deck was caulked with wooden laths fastened with nails.

None of the deck beams of the forward or stern decks had been fastened to the shelf. Instead, they were fastened to the hull via waterways and rider beams (Fig. 13). The rider beams were laid down over the deck, generally from side to side, so as to sandwich the decking between themselves and the beams. Each of the surviving ends of the rider beams ended in a vertical knee, which was integral with the timber and was fastened to the framing with a single treenail. The rider beams were in turn fastened through the decking to the beams with treenails thereby connecting the beams to the hull and framing. The configuration of the missing rider beam ends is not known.

In addition, a waterway was placed along either side of the decks. These were fastened to the framing and beams with treenails.

The decking seams were caulked with sinteling on the forward and fishwell decks, while the stern deck was caulked with wooden laths fastened with nails.

### The Stern Deck

As previously mentioned, the stern deck planking was still attached to the deck beams although the entire structure had collapsed into the vessel. The stern deck rested on four deck beams. Some rough sketches were made of these beams, but their shapes and dimensions were not otherwise recorded.

Although all the beams were poorly preserved, the original lengths of two survived. The first beam aft of the fishwell was the heaviest and the broadest, but its starboard end was missing. In the underside of the beam were two notches: one for the stanchion, and the other possibly for a diagonal timber bracing the stanchion. All surviving beam ends were dovetailed to fit into the notches on the shelf.

The surviving deck (Fig. 28) consisted of five planks, four of which fanned out from the post and ran the full length of the deck. This created a gap down the

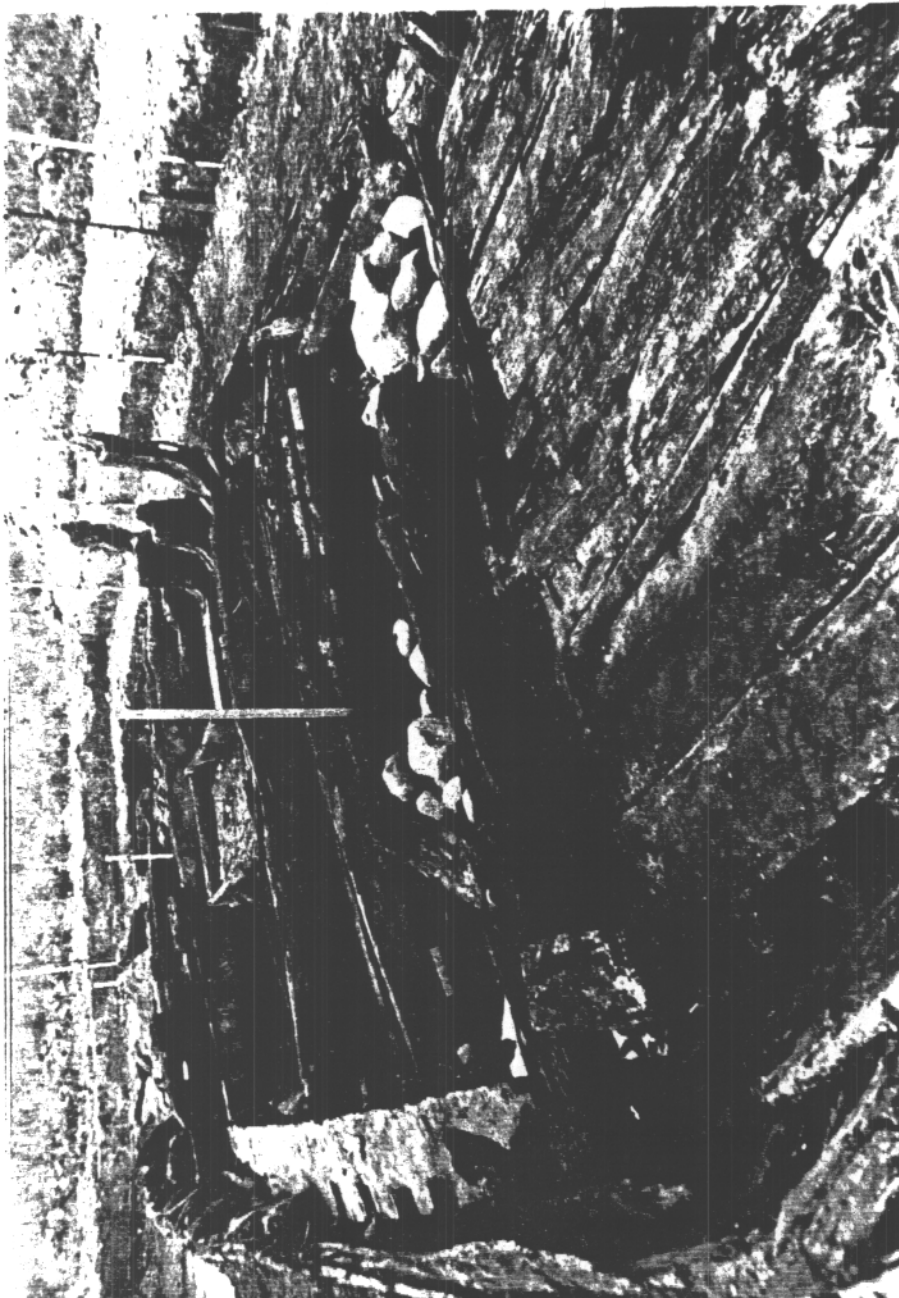

Figure 28. The stern deck, living quarters and fishwell deck as viewed from the port stern quarter (courtesy of RIJP).

middle into which the fifth plank, a stealer, was fitted.

While the other decks were sinteled, the seams on this deck were sealed with rounded laths 9 cm. broad and 2 cm. thick (Fig. 29). These were nailed to the planks along both edges. Whether the laths were caulked with moss is not known, but this can be assumed, since this would be necessary to create a watertight seal.

On the forward end of the deck, part of a rider beam was fastened on top of the planking above the first beam (Fig. 28). In its aft face was a rabbet 6 cm. wide. In the rabbet was a row of nails protruding 4 cm. On the rider beam's forward face a small vertical rabbet was located near its port extremity. Lying on the ballast was another timber with a similar rabbet and a piece of lath attached. This timber was a piece of the rider beam.

#### The Forward Deck

As already mentioned, only the port side of the forward deck survived. This consisted of a kingplank, decking, a waterway, deck beams, and rider beams. There were also substantial remains of the starboard kingplank.

There were seven deck beams on the port side. Four of these originally ran from side to side and are hereafter referred to as full beams. The other three were beams

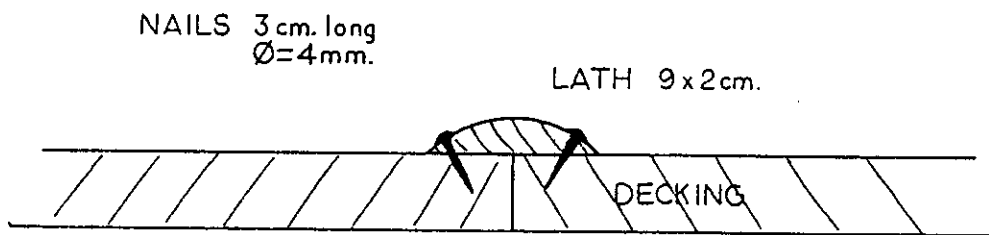

Figure 29. Detail of the caulking laths on the stern deck. The shapes of the laths and nails are reconstructed. (Not to scale).

which ran between the kingplank and the waterway and are hereafter referred to as half beams.

Although the deck had collapsed into the wreck, it was not shifted out of place. Thus, the three aftermost full beams were found in their original positions. The fourth full beam, the beam nearest the stem, was found lying askew in the bow. The full beams were located 66 cm., 1.2 m. and 3.77 m. forward of the forward bulkhead. The extreme forward section of the shelf was missing, but the placement of the fourth full beam was indicated by a treenail in the port kingplank 5.15 m. forward of the bulkhead.

The three half beams were also found in their pre-wreck positions. They were located 1.86 m., 2.48 m. and 3.15 m. forward of the bulkhead, between the second and third full beams.

The respective molded and sided dimensions of the four full beams were, from aft forward, 30 cm. by 18 cm., 30 cm. by 18 cm., 30 cm. by 16 cm., and 27 cm. by 15 cm. The dimensions of the three half beams were, from aft forward, 6.5 cm. by 16 cm., 11 cm. by 12.5 cm., and 7 cm. by 13 cm., molded by sided.

Placed over the deck beams were two kingplanks, both of which were missing their forward extremities due to decay. The port kingplank was 5.80 m. long; the

starboard one, 4.20 m. long. The port kingplank was 40 cm. wide and 10 cm. thick at the after end and had a rabbet 4 cm. wide and 8 cm. deep along its outer edge to accommodate the ends of the half beams. The starboard kingplank was too degraded for the excavators to record accurate data. The after ends of the kingplanks were set into shallow notches on top of a bulkhead above the forward fishwell bulkhead (discussed below). How they were fastened to the bulkhead is not known. The kingplanks ran forward from the bulkhead not quite parallel to each other, leaving a space between them 40 cm. wide at the second full beam and 36 cm. wide at the third full beam. They were fastened to the deck beams with treenails 3 cm. in diameter.

Along the port bulwark was a waterway. Its surviving length forward of the fishwell was approximately 5 m. The waterway ran aft above the fishwell deck to the cabin area (Fig. 28) where, at the after bulkhead, it was broken and sloped down into the cabin. Aft of the cabin area, the port waterway was no longer extant. The entire starboard waterway had disappeared as well.

At the forward bulkhead, the port waterway measured 52 cm. wide by 10 cm. thick. At the third full deck beam the waterway was 40 cm. wide by 7 cm. thick. At 1.84 m. forward of the bulkhead the waterway was joined with a

horizontal scarf, which was caulked with moss and fastened with iron nails along the joint. At its forward extremity, the waterway had a finished end for the joining of yet another length.

The waterway rested on top of the full beams and was fastened to them with two treenails per beam. In addition, it was fastened to each frame with one treenail which was hammered horizontally through the waterway into the frame. Along most of its surviving length the waterway was notched to fit around the frames. However, from the third full deck beam to its forward end, the waterway only butted against the inner faces of the frames.

The area between the waterway and the port kingplank was decked with three planks 5 cm. thick, which were fastened to the beams with two treenails per plank. At the first full beam the widths of the planks were, from outer to inner, 32 cm., 41 cm. and 49 cm. In order that the decking would lay level with the top surfaces of the kingplanks and the waterway, furring strips were laid on top of the beams (Fig. 13).

In contrast, the three half beams sat directly against the underside of the decking (Fig. 30). Their outer ends were notched on the upper face to fit the underside of the waterway, while their inner ends were notched on the

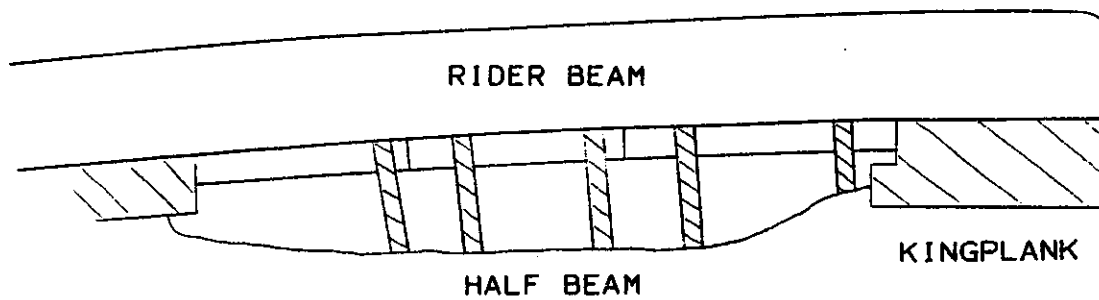

Figure 30. Drawing of a half beam and associated timbers.  
(Not to scale).

under side to sit in the rabbet in the kingplank. The half beams were not fastened on either end and were held in place only by their fastenings to the decking. This indicates the two men were needed to set the half beams: one to hold the beam in place and another to bore the treenail holes and insert the treenails.

Over the aftermost half beam the decking had been cut away to create an opening 1 meter long by 80 cm. wide on its after edge and 72 cm. wide on its forward edge. The treenails that held the decking in place before it was cut and removed were left protruding from the beam. A lath was nailed along the after end of the opening, either for use as a carling or a coaming.

Rider beams ran across the decking above the deck beams. These were found still in place above the second full beam and above the second half beam. There was also an impression of a rider beam in the decking above the first full beam. An additional rider beam was found lying loose in the bow. The one over the second full beam, hereafter referred to as the second rider beam, was sided 25 cm. and molded 12 cm. over the kingplank and molded 20 cm. over the waterway. The half rider beam was sided 19 cm., but no molded dimension was recorded for it. The loose rider beam was 24 cm. sided by 18 cm. molded. The height of the outboard end of this rider

beam was 55 cm., and its top was molded 28 cm. and sided 22 cm. Its molded faces were perpendicular to its bottom face.

The second rider beam originally ran from side to side, while the half rider beam ran only to the inner edge of the kingplank where it was finished off.

As mentioned above, the rider beams served to sandwich the decking between them and the furring strips or beams. They were fastened to the kingplanks and through the decking into the deck beams with treenails 3 to 3.5 cm. in diameter. A single iron spike was found driven through one of the rider beams and into the underlying beam. It was 57 cm. long and 2.5 cm. square in section.

Between the kingplanks, the area between the second and third full beams was left undecked. This area was 2.35 m. long, 40 cm. wide aft and 36 cm. wide forward.

There were two mortises and a notch along the inboard edge of each kingplank (Fig. 31). The first was located just aft of the second rider beam. The other two were located forward of the second rider beam along the opening between the kingplanks.

The first mortise was 3 cm. deep, 3.5 cm. wide and 12 cm. long. Its length was equal to the distance between the second rider beam and the impression of the rider beam on the decking above the first beam (Fig. 31).

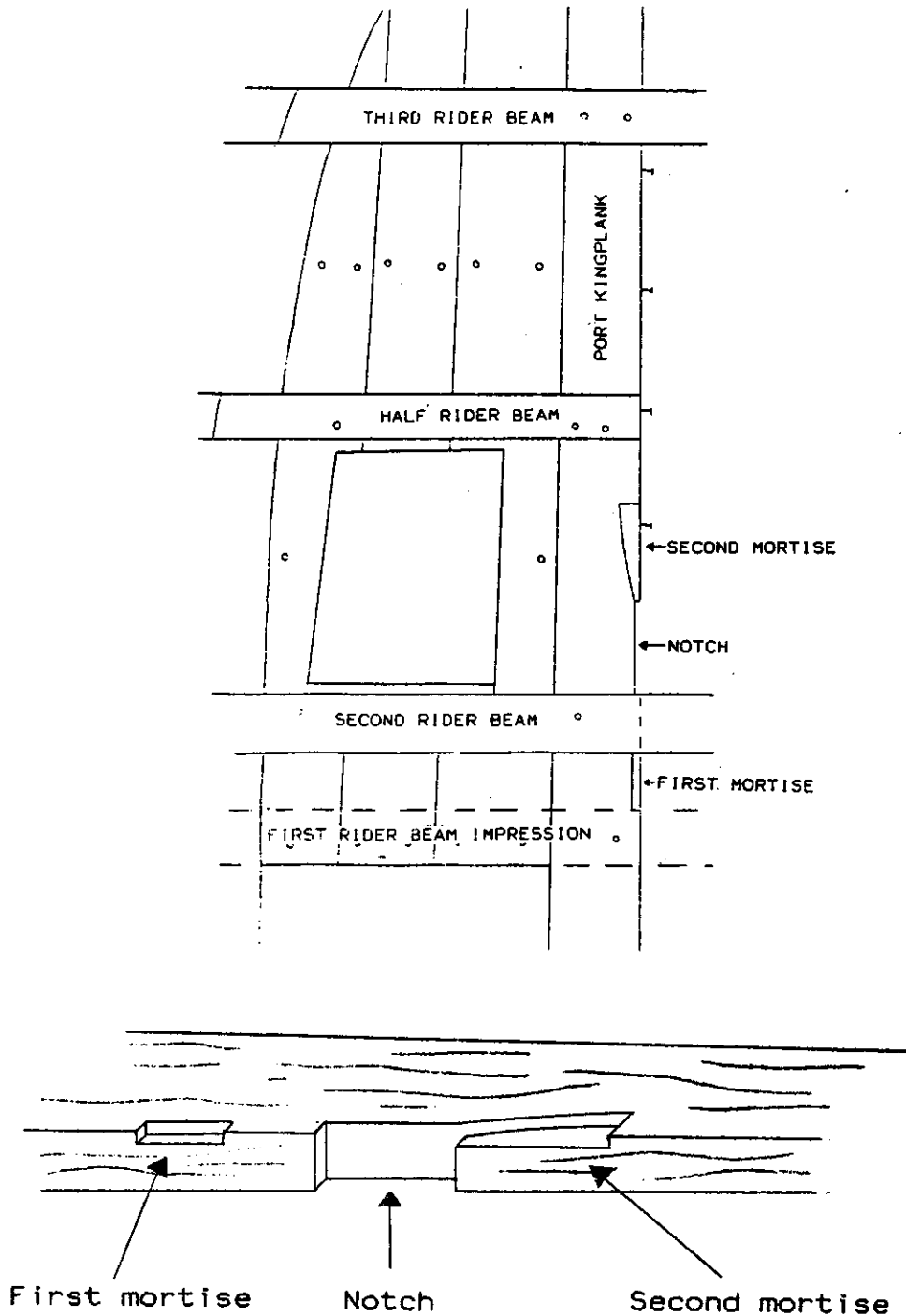

Figure 31. Two views of the port kingplank showing the mortises and notch for the mast partners. (Top: not to scale. Bottom: 1:20).

The second cut, a notch, immediately forward of the second rider beam, was 2 cm. wide by 40 cm. long and ran from the upper face of the kingplank to its lower face (Fig. 31). Into this notch, was placed a timber 40 cm. broad and 2.5 cm. thick. This extended from the upper face of the kingplank to the groove alongside the mast socket. The timber had no fastenings at either end and, with its starboard counterpart, formed a chute, or sheath, alongside the mast. At the top, a space 39 cm. wide was left between the timbers for the mast.

The other mortise was located immediately forward of the notch. Its width was 2 cm. aft and 8.5 cm. forward. Its depth was not recorded and is presented only as a reconstruction in Fig. 31.

On the inner faces of the kingplanks, between the "mast-sheath" boards and the third rider beam, there was a row of small nails set 51 cm. apart. These were possibly fastenings for laths forming a coaming. As such, the laths would have allowed the positioning of a hatch or additional mast partners over the slot. No such mast partners or hatch were found.

The after end of the deck was at the first full beam. The area between the beam, the forward fishwell bulkhead, the waterway and the kingplank was left undecked. This

area was located over the gutter mentioned above (p. 52). There were no traces of a coaming or hatch.

### The Fishwell Deck

The fishwell deck (Fig. 32) had collapsed but otherwise remained intact. The decking originally rested on the three bulkheads and on four thin deck beams. The sided by molded dimensions of the beams were, from forward aft, 11.5 cm. by 9 cm., 9.5 cm. by 8 cm., 11.5 cm. by 9 cm., and 9.5 cm. by 8 cm. Their ends were notched to fit in notches on the frame tops like that on frame B (p. 49). The decking, as seen in the stereophotograph of the decks (Fig. 3), consisted of 12 longitudinal planks, each approximately 5 cm. thick. Their widths ranged between 34 cm. and 44 cm.

Along the deck's outer edges were waterways which were 10 cm. thick on their outboard edges and 5 cm. thick on their inboard edges. The waterways and the decking were fastened to the beams with treenails and to the bulkheads with both treenails and iron nails. In addition, the waterways were fastened to the hull with the thin treenails in the sixth strake at the upper limit of the hole pattern (p. 24). The treenails were spaced approximately 15 cm. apart.



Figure 32. The fishwell deck viewed from starboard with the starboard knees set back in place. Note the nearly intact top of the knee on left (courtesy of RIJP).

As previously mentioned, the decking seams were caulked on the upper surface with moss and laths held by sintels. The sintels measured 7 cm. long by 2.5 cm. wide and were spaced approximately 8 cm. apart.

In the middle of the deck was an opening for access to the fishwell (Figs 32, 33). This opening was 1.25 m. long by 78 cm. wide. Four walls stood around the opening forming a trough 61 cm. high. Each of the four walls consisted of an upper and a lower component. The walls forward and aft stood between the side walls with their tops joined as shown in Fig. 33. The lower components were 6.5 cm. thick and 45 cm. high, while the upper ones were 5 cm. thick and 16 cm. high. The components of the forward and after walls were of the same heights as the side walls but were thinner with a thickness of 6 cm. for the lower members and 4.5 cm. for the upper ones. The wall components were joined on edge by thin treenails hammered in from the top edge of the wall. These treenails extended into the lower pieces approximately 12 cm. The corner joints were fastened with iron nails, one in the upper pieces and two in the lower ones. The forward and aft walls sat in rabbets in the decking, while the sidewalls were nailed into the edges of the decking.

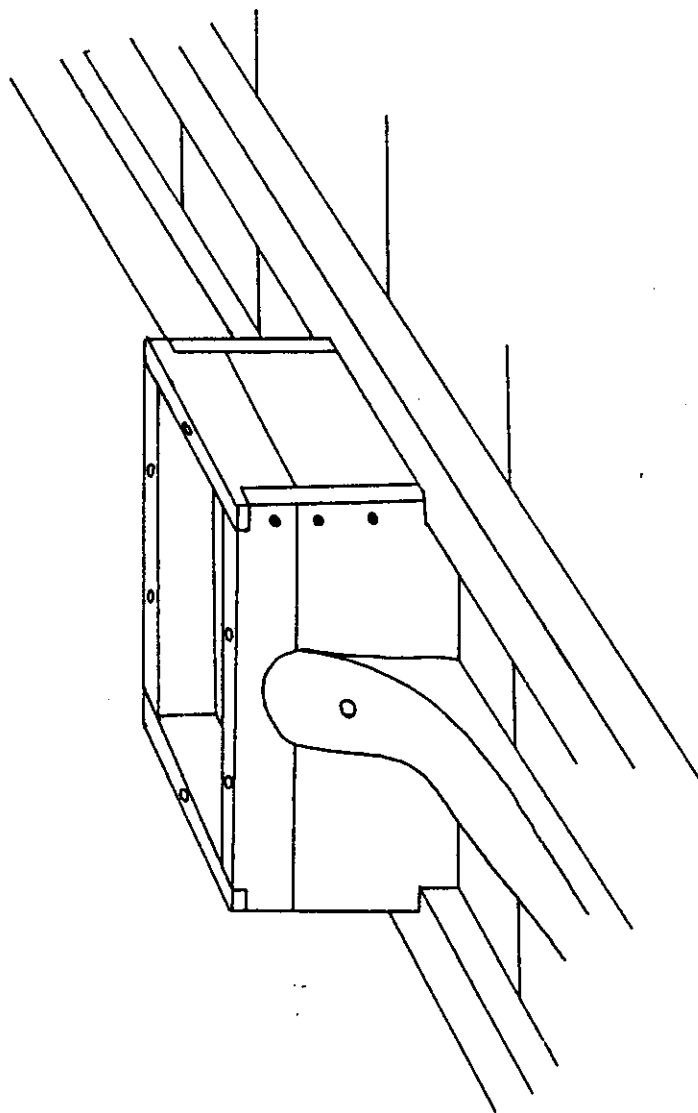

Figure 33. Drawing of the trough (after a drawing by RIJP).

Inside the trough, near the center of either side wall, were two vertical laths. The distance between the laths of either set, as well as their dimensions, was not recorded.

The sides of the trough were supported on the outside by rider beams. These were sided 21 cm. and were carved in the shape of knees on the ends against the trough and had either a carved knee or futtock on the outer ends against the hull. Thus, they supported the sides of not only the trough but also the hull (Fig. 34). The ends against the trough rose to a height halfway up the walls' upper components. The rider beams were placed on top of the decking over the middle bulkhead and were treenailed to the trough's walls, to the bulkhead beneath, and to the hull planking.

In addition to these two central rider beams, there were two rider beams between the trough and the forward bulkhead and three aft of the trough. Unlike the central rider beams, these ran from side to side and were lighter, each approximately 13 cm. sided and 15 cm. molded. Each rider beam sat over a deck beam except for the aftermost which rested over the after bulkhead. The rider beams immediately forward and aft of the middle bulkhead were rabbeted along one side to fit around the ends of the trough (Fig. 33). All the rider beams were



Figure 34. The fishwell deck viewed from port. Note the large riders supporting the trough (courtesy of RIJP).

treenailed through the decking into the underlying timbers.

The outer ends of the rider beams had remains of vertical, carved knees or wide futtocks which would have stood against the strakes. These provided the only internal support for the planking in the fishwell. The futtocks were scarfed on top of the rider beams and fastened to them with three treenails. They were also fastened to each of the strakes they stood against with two treenails per strake.

Most of the knees and futtocks were partially decayed, with the ones on starboard displaying greater deterioration. An exception to this was the futtock of the central starboard rider beam (Fig. 32). This timber had become detached early in the decomposition of the vessel and was therefore virtually intact. When this timber was reset it stood approximately 1.1 m. above the deck. Except for the top of the rabbet on the stem, this height was the only indication of the top of the sheer strake. In addition, the top of this timber was notched to receive the sheer clamp.

The outer ends of the central rider beams were molded less than those of the other fishwell rider beams, which were notched on level with the waterway of the forward and stern decks. The waterway sat in these notches, and

these timbers supported it as it ran from the forward deck to the stern deck. Thus, over the fishwell deck, the waterway served as a gangway. It was fastened to each rider beam end, or top, with a treenail in the same manner as to the frames in the bow. Additionally, as previously mentioned, the gangway was notched to fit around the rider beam ends (Fig. 28). At the after end of the fishwell, the gangway was 8.5 cm. thick and 44 cm. wide between its inboard edge and the rider beam end.

Over the forward bulkhead sat another, smaller bulkhead instead of a rider beam (Fig. 28). This bulkhead was sided 13 cm. and molded 45 cm. The timber originally ran from side to side, but its starboard end was no longer extant. The bulkhead not only supported the ends of the kingplanks (p. 64), but also served as a rider beam for the forward end of the fishwell deck and as a partition between the fishwell area and the forward section of the vessel. The surviving part of the bulkhead was composed of two parts joined by a vertical scarf near the waterway. These two parts included the main section of the bulkhead, which ran over most of the breadth of the deck, and an end piece which supported the waterway/gangway and the vessel's side in the manner of a fishwell rider beam end. Whether the construction on the starboard side was the same is not known.

As seen in Fig. 28, above this bulkhead sat yet another timber. This was notched to fit over the kingplanks and the waterway. Over the waterway, this timber's height decreased by 8 cm. The middle section of the timber was also reduced in height. The timber was fastened to the bulkhead beneath it with an iron spike hammered through its top face 1.46 m. from the vessel's centerline. The spike was 56 cm. long and 3 cm. square. Like the bulkhead beneath, the starboard side of this bulkhead was no longer extant. It was not recorded whether there were any traces of a similar spike on the starboard side.

Another bulkhead was located at the after end of the trough. This consisted of two light planks, one placed on top of the rider beam on either side of the trough and joined to its end with vertical scarfs, which were apparently fastened with nails. The length of these scarfs were approximately 6.5 cm. As seen in Fig. 28, the two bulkhead members ran out to the rider beam ends where they were apparently scarfed onto them. The length of these scarfs is not known. The planks forming this bulkhead were approximately 5 cm. thick and had a surviving height of approximately 40 cm.

Another feature of the fishwell deck was a small, narrow member bridging the space between the port central rider beam and the rider beam immediately aft of the

trough. As can be seen in Fig. 34, this timber was nailed onto the central rider beam and had a rounded or chamfered upper forward edge. The piece passed under the thin bulkhead on the rider beam and came out on the bulkhead's after side. There was no similar feature to starboard.

All the rider beams on the fishwell deck except for the sternmost had limber holes. The bulkhead above the forward fishwell bulkhead had 3 triangular limber holes, one towards either end and one near the center. The limber holes in the other rider beams had no standard shape. Each rider beam had a limber hole located over the juncture of the waterway and decking on both sides of the deck.

#### Additional Timbers

Additional parts of the vessel found on the wreck or close by included a length of planking, two pieces of planking fastened to each other and a piece of wood triangular in section approximately 10 by 22 cm.

The first length of planking had nail holes along one edge in the same fashion as a strake landing.

The two pieces fastened together were approximately 5 cm. thick and showed evidence of wear from towing along one edge. It is not known whether these two attached

planks were fastened on their edges or ends. The breadth of each plank was 25 cm. by the forward edge and 30 cm. broad 1.5 m. aft of the front end. No other details were recorded for these pieces or for the triangular piece.

There was an additional plank fragment for which there is only photographic evidence (Figs 35, 36). This plank had nail holes spaced approximately 15 cm. apart along both edges. It also had an end which was angled in such a manner that it might have been a hood end. There were also eight large holes in the plank which were probably for the framing treenails.

### Mast and Rigging

Only the foot of the mast survived. While its dimensions were not recorded, it can be assumed that the foot was the same size as the socket, namely 31 cm. by 46 cm.

There was only one element of the rigging found on the vessel. This was a deadeye found on the exterior of the hull near the port end of the second forward deck beam. The deadeye was made of wood and iron. There was no further information recorded concerning this piece.

### Ballast

Ballast was found in both the stern and the bow. It consisted of irregularly shaped stones, some of which

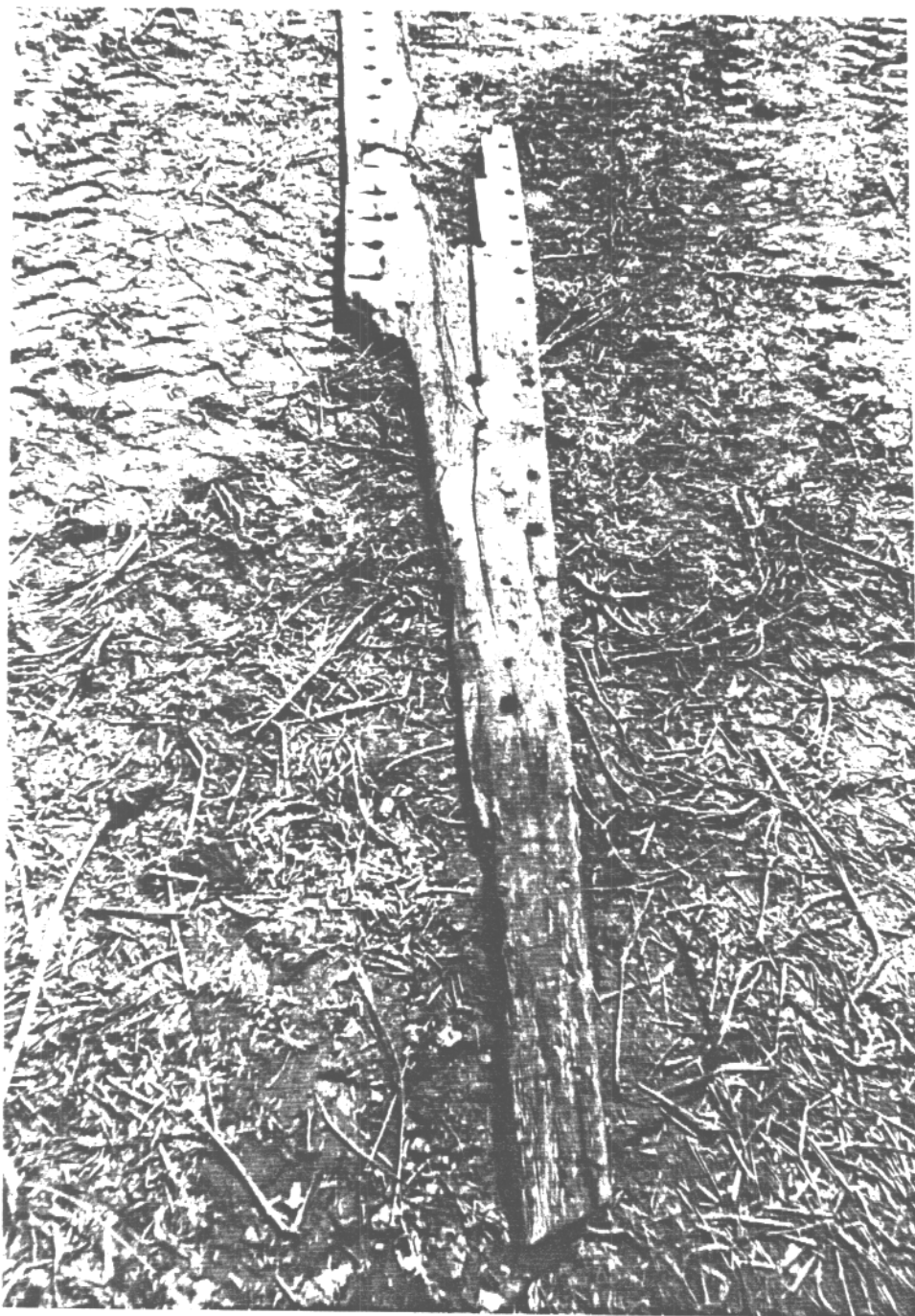

Figure 35. A plank with an apparent hood end, treenail holes and nail holes (courtesy of RIJP).

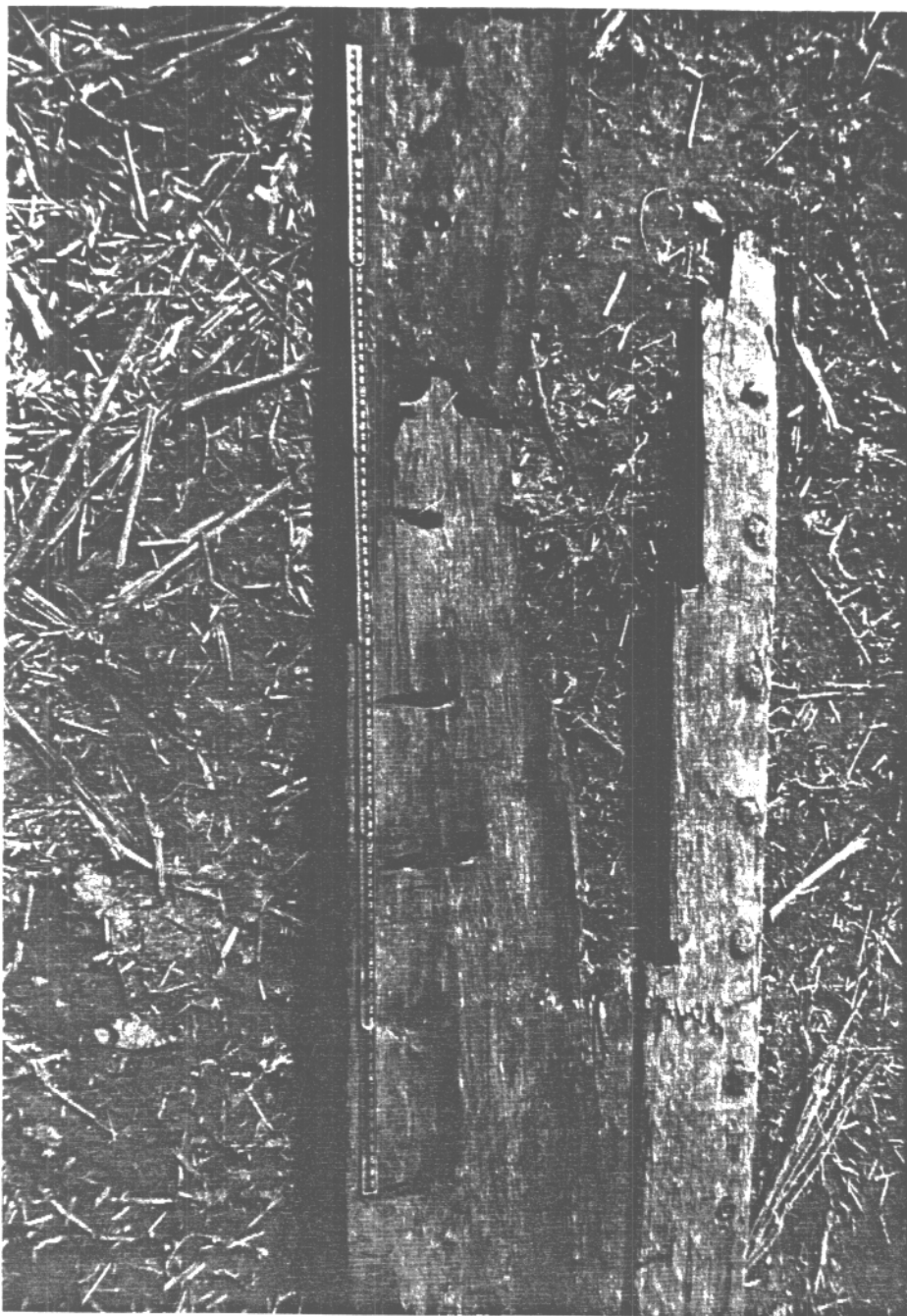

Figure 36. Detail of Fig. 35 (courtesy of RIJP).

were rounded. In the stern, the ballast laid on the ceiling in the cabin area, although a few stones had rolled off the ceiling and onto the strakes. In the bow, the ballast was stacked around the foot of the mast in a pile 30 cm. high which helped preserve the mast foot (Fig. 37). There was one additional boulder lying in the gutter aft of the mast.

There was a total of 499 ballast stones. The ballast weight astern was 3660 kg. and the weight forward was 1590 kg. The total weight of the ballast was 5250 kg. The average boulder weight was 10.5 kg.

## Artifacts

### Ceramics

A number of red earthenware vessels, both intact and broken, were found on the vessel. These were found in the cabin area although a few sherds were found on the fishwell deck. The finds included cooking pots, tankards, saucepans, pitchers large and small, bowls, and a plate. All the pots had bottoms blackened by fire. The vessels were glazed brown although a least one pot had green glazing inside. Each of the cooking pots had strong rings around the neck and shoulders and had three knob-like feet. The saucepans also had three knob-like feet. The pitchers were of the baardman type with drab



Figure 37. The mast foot with its supporting ballast pile (courtesy of RIJP).

gray glazing. There were also several intrusive ceramic pieces dating to the seventeenth to nineteenth centuries.

Nineteen floor tiles were found in the cabin lying on top of the ballast. These varied in size, although most were 13 cm. square and 3.5 cm. thick. The largest of the tiles was 17 cm. square and 3.5 cm. thick. The glazing on the tiles varied from tile to tile and included lead glazes of brown-yellow, green-brown, yellow-green, dark brown-green and dark brown. All of these tiles had a small hole in each corner from the mold. Also, one tile had an additional hole through its middle.

### Brick

There were three brick fragments found lying amongst the ballast in the cabin. One fragment had some mortar stuck to it and another had one smooth side, possibly for use as a whetstone. The third piece was a net weight, discussed below.

### Copper

There was only one artifact made of entirely of copper. This was a small round buckle found lying on one of the stringers in the cabin.

## Iron

Twenty iron artifacts of various types were found at various places on the wreck. These were:

- a small iron ring, 2 cm. in diameter and 3 mm. thick.
- an iron striker (for use with flint) found aft of the cabin between the floor timbers.
- a blade fragment with a wooden handle found on the keelplank aft of the cabin.
- the remains of a knife with a bone handle adorned with small rings set with copper nails. Found in the cabin area.
- three fragments of table-knife blades. Found in the cabin.
- a fragment of an iron clasp. Found in the cabin.
- a small iron key. Found in the cabin.
- a flat piece of an iron band forged from nails. This was found lying near the stem on starboard.
- several nails lying loose in the ship. There were six nails 9 cm. long, eight small nails of various lengths, two nails 20 cm. long, a nail 12.5 cm. long, and four pieces of a nail 9 cm. long.
- three loose sintels lying in the stern.

### Wood

There were also various wooden artifacts found on the wreck. One was an eight-sided piece with two projections, three holes bored through and traces of wear. This was found in the stern and its function is not known. Another was a small round piece found against the after bulkhead in the cabin on port. This also had traces of wear. A wooden sheave lying on the stern ballast was also found, as were wooden galley implements such as a mug, a ladle fragment and a scrubbing brush.

### Leather

Seventeen pieces of leather shoes, soles and uppers were found lying amongst the ballast in the cabin. Among these were two nearly intact shoes. These were both large, man-size shoes, one of which had shoelaces and was roughly made, while the other was an open type of shoe with decorative stitching. The other shoes were poorly preserved and included fragments of boy-size shoes.

### Bone

Various bones were found in the cabin lying amongst the ballast. There were three small bird bones; three pig bones, including a rib fragment and two leg bones; and eleven cow bones, including vertebrae fragments, leg bone

fragments, a pelvis fragment, and a shoulder blade fragment.

### Peat

Two pieces of peat were found on the wreck. One piece was found lying on the after end of the fishwell deck, while the other was found lying on the stern ballast.

### Stone

There were a few stone artifacts which were not used as ballast. One of these was a piece of limestone which, due to its size and shape, could have been material for a net weight similar to the limestone net weight mentioned below. Two other stones were flints, both of which were burned and cracked by fire. These three objects were found lying amongst the stern ballast. Some other stone objects found were net weights, discussed below.

### Fishing Gear

Several artifacts belonged to the ship's fishing tackle. Two of these were the side pieces of a winch (Fig. 38), found in the aft section of the wreck. These pieces both measured 45 by 55 cm. although one was 14 cm. thick and the other 10 cm. thick. Both had an iron bolt or spike passing through the piece and protruding from the back

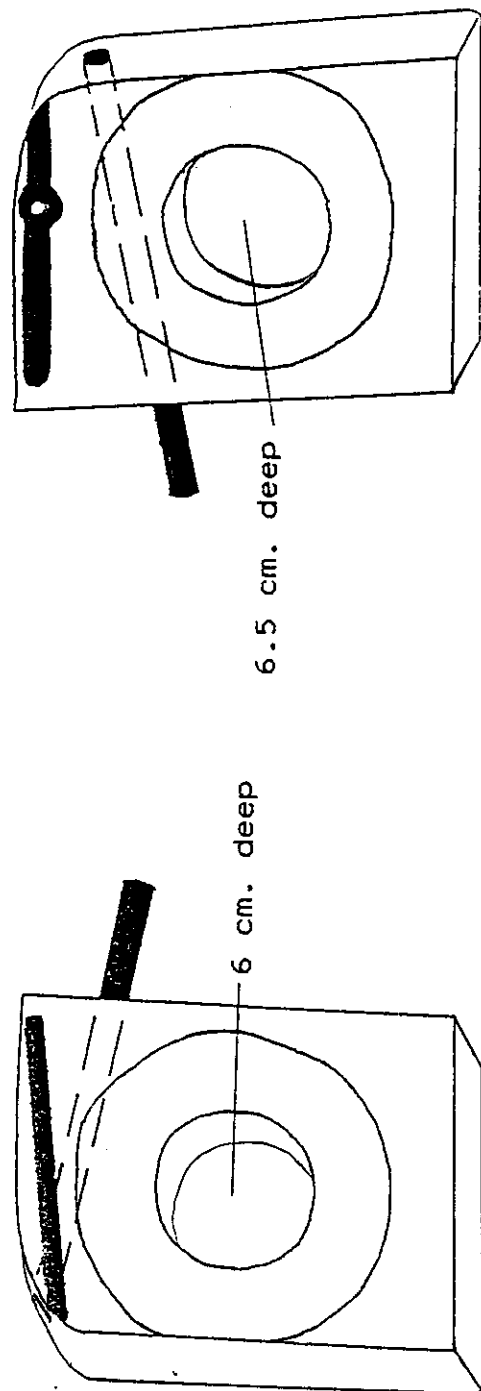

Figure 38. The pieces of the winch (after a drawing by RIJP).

side. Since these pieces were found in close proximity to one another, they may have belonged to the same winch.

Two stone net weights were found. The first of these was a small fragment of brick with a hole through it. This was found near the sternpost. The other was a piece of limestone also with a hole bored through. This was found on the keelplank in the stern.

No nets, ropes or hooks were found on the vessel, either due to deterioration or salvaging.

## CHAPTER IV

## RECONSTRUCTION AND METHODOLOGY

## Introduction

Reconstruction involves working with two media, the tangible and the intangible. With the first, the reconstructor works within the parameters of physical evidence, such as dimensions, shapes of timbers and the locations of fastenings and artifacts. Working with the intangible, however, he must deal with what has since disappeared. To reconstruct the vanished members, the reconstructor must draw on parallels from other vessels, construction methods, inferences from surviving parts of the vessel, and his own intuition. Thus, conclusions are achieved through a combination of physical evidence, feel and general knowledge.

Depending on the degree of importance applied to the various aspects, the results can vary since no two people will interpret the same data in the same way. While one may arrive at a more complex solution, the other may arrive at a simpler one. Which result is more accurate may only be subjective.

In this study, a minimal approach was taken. There are areas where various routes of reconstruction could have

been taken. However, the course chosen was that which would be the easiest to prove and involved the least complications. The more elaborate a reconstruction becomes, the greater is the risk that it would stray from original reality. Simplicity, on the other hand, increases the chances of correctness by avoiding anachronisms, unfounded inventions, and compounded errors. Thus, at all times, Einstein's maxim "make solutions as simple as possible, but no simpler" was followed.

The reconstruction procedure mimicked the construction sequence from the laying of the keelplank to the finishing of the deck structure.

In order to reconstruct the waterschip NZ421, a number of measurements, dimensions and fastenings were reconstructed by taking them from photographs and the stereographic plottings and correlating them to known measurements. For example, the planking and scarf lengths were determined in this manner (p. 28). Also, the stereophotograph of the decks (Fig. 3) was used to determine the widths of the fishwell deck planking, since they were not presented in the excavation notes. Photographic distortion, resulting from the list to port and the pitch forward, was corrected by comparing the

decking widths in Fig. 3 to reconstructed section drawings. The stern deck was similarly reconstructed. Likewise, the positions of the third and fourth stern deck beams and the position of frame 0 were determined by taking measurements from various photographs.

### Keelplank and Posts

As mentioned in chapter III, the keelplank was distorted. NZ421 was reconstructed with a straight keelplank-line since the reconstructed waterschip W10 did not have a rockered keel. Also, some constructional evidence supported the use of a straight keelplank. This was seen in the extreme bending of the garboards as they went from a nearly vertical position at the post to a nearly horizontal position amidships and then back again to a vertical position at the stem. This is called "rolling-in" and is "most marked in the garboard of a straight-keeled boat" (McKee, 1972: 3).

The keelplank's molded dimensions were obtained from the stereographic plottings of the planking and the body sections, while its sided dimensions were taken from the excavation drawings and notes.

The stem had been drawn and reconstructed by the RIJP staff and no further reconstruction work was needed.

The sternpost, however, needed much work, since its

upper extremity was no longer extant. The reconstruction of the post's height and shape was partly based on a comparison with the post of W10. The shape, particularly the curve on its forward face, was further refined as the planking was reconstructed, as will be seen below. The joggling of the post's rabbet was noted by the excavators but not otherwise recorded (p. 19). Hence, these were reconstructed once the placement of the hood ends was determined.

#### The Lines and the Planking Model

Once the keelplank was adjusted, the vessel's lines were begun. The port side was chosen for reconstruction since it was the better preserved. The central part of the wreck was reinforced with the fishwell bulkheads, and it was assumed that this section was the least distorted. Thus, the bulkheads were used as the basis for determining the shape of the vessel. This assumption proved to be somewhat correct. As seen in a comparison between the reconstructed sections and the actual ones of the wreck (Fig. 39), the distortion is greatest towards the ends although many of the sections display only slight distortion.

Nevertheless, throughout the drawing process, sections 5 and 9 were treated as almost inviolable. Thus, if a

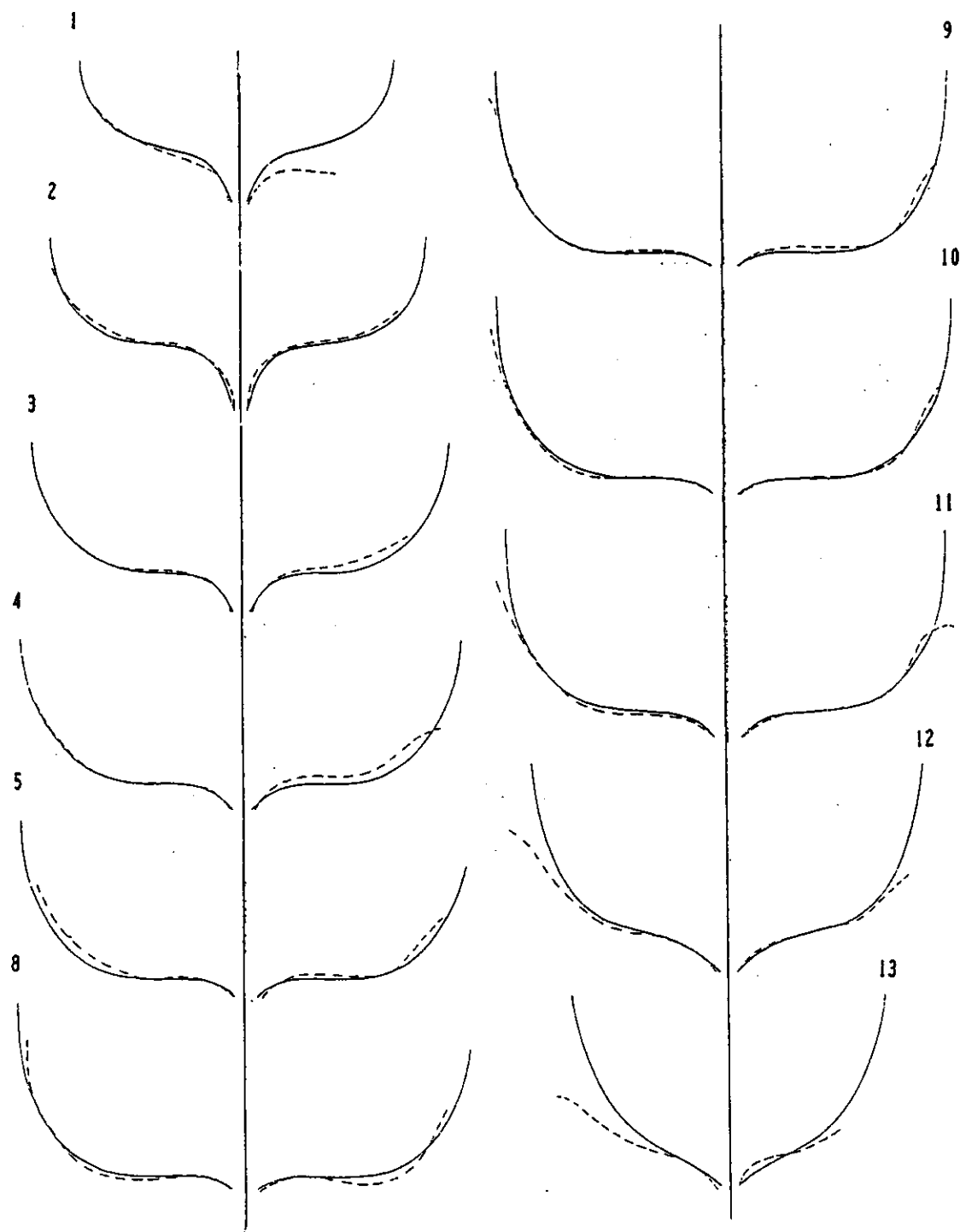

Figure 39. Comparison between reconstructed and actual sections of the wreck (dotted line).

buttock or water line needed adjustment, it was done so these stations would not be affected. In other words, the shapes of the other body stations were dependent on stations 5 and 9.

Since one side of a vessel will usually yield an accurate picture of the appearance of the entire vessel, only one side needs to be reconstructed. This is particularly true of clinker-built vessels where each side of the vessel is planked in a similar manner (Leather, 1973: xv). This concept is illustrated in Figs 40a and b, which show the similarity of the planking widths of NZ421 on both sides. The graphs display the widths of the six strakes on port and starboard from body stations one through thirteen. Not only are the similarities of the planking widths illustrated, but the similarities between the shapes of the port and starboard strakes are also demonstrated. This resemblance enabled the reconstruction of widths where the planking did not survive. Additionally, the reconstruction of the widths of missing starboard planks could be made based on the extant port widths. Also, the missing width of a plank could be estimated by following the graph line.

All the body sections used in reconstructing the lines were based on the sections from the stereographic plottings which displayed the surviving strake landings.

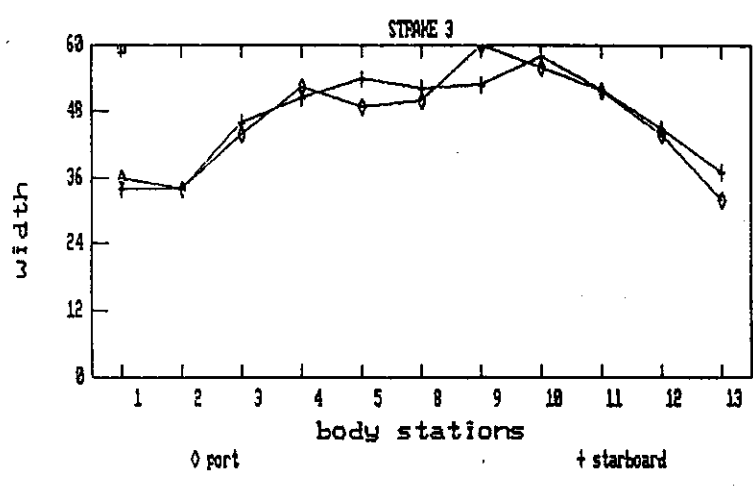
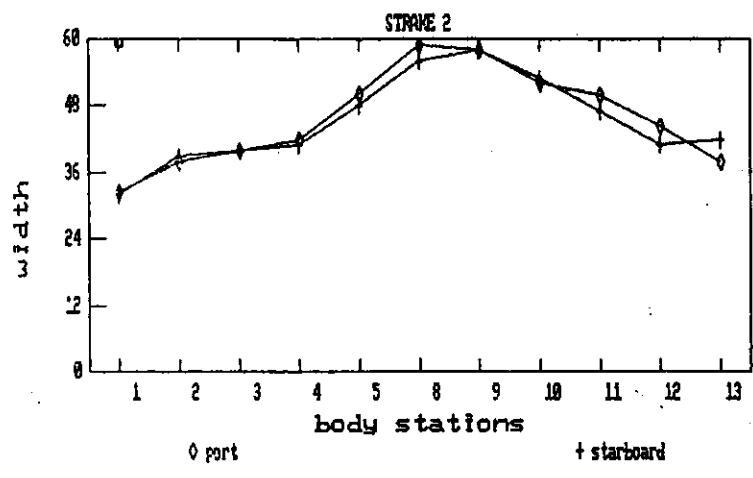
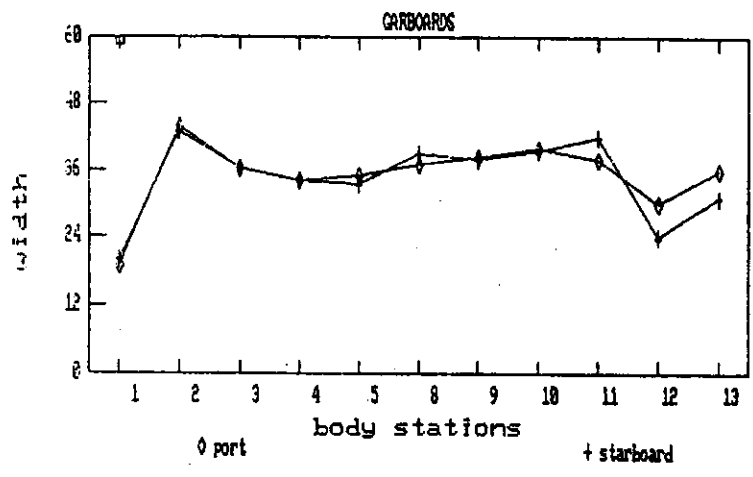

Figure 40a. Graphs of the widths of the first through third strakes on both sides of the vessel.

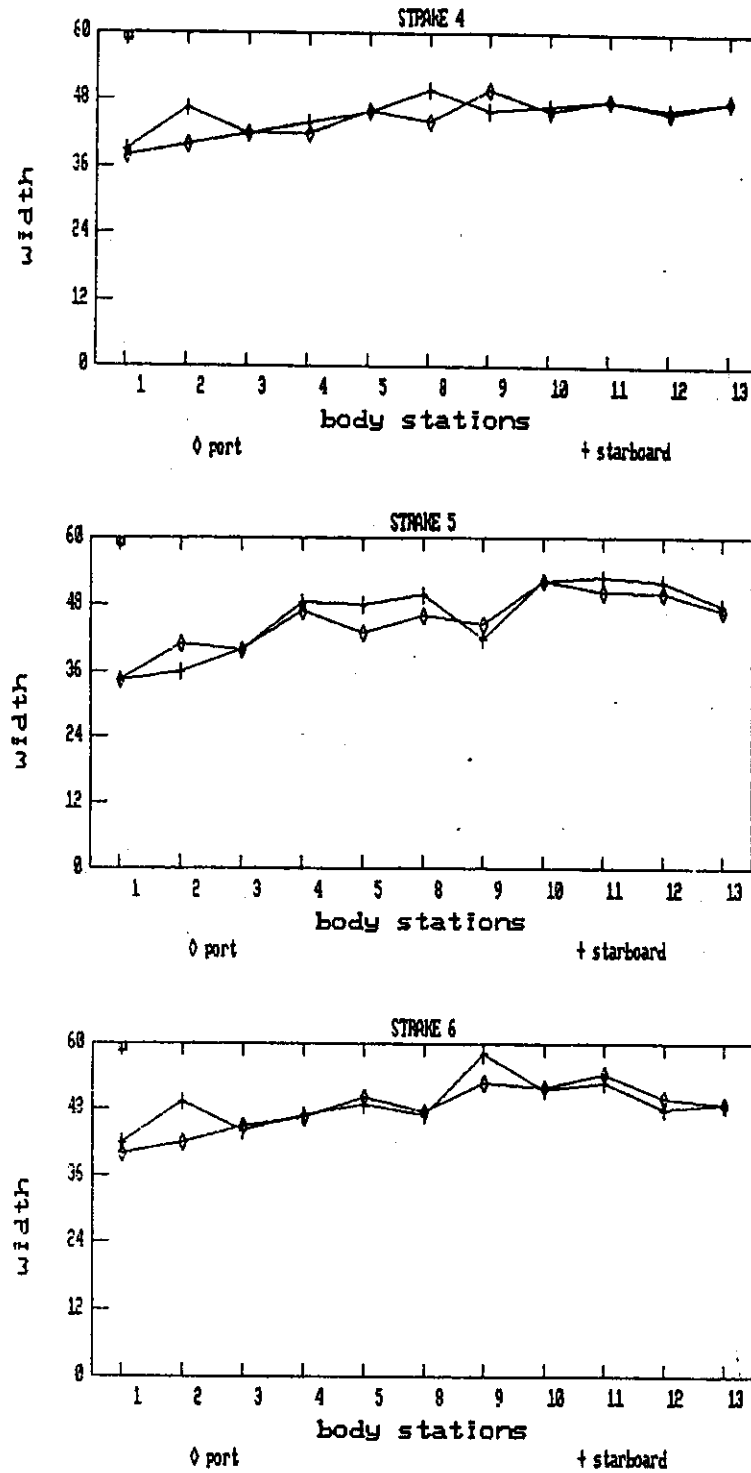

Figure 40b. Graphs of the widths of the fourth through sixth strakes on both sides of the vessel.

The sectional curves were taken through the points of the inner top corners of the planking. Consequently, the lines became an image of the vessel between the planking and the framing. This, of course, resulted in the lines drawing being of smaller dimensions than the actual vessel, but only by the thickness of the planking. Coincidentally, the traditional Dutch method was to measure ships and boats inside the planking (Anderson, 1982: 16).

Amidships, the top of the eighth port strake survived, while the highest extant landing near the ends was that of the sixth and seventh strakes. Combined with the knowledge that the ship's ends and upper works were distorted, the missing planking made impossible an accurate estimation of either the sheer line or the run of the planks in the ends.

Thus, it was necessary to draw the lines in two stages. The first stage was a reconstruction of the lines through the sixth strake. Additionally, each station was extended in a fair curve to intercept any reasonable sheer line. The second stage was the drawing of the lines from the level of the sixth strake combined with the simultaneous construction of a planking model. From this, the sheer, the shape of the vessel's ends and the run of the vanished planking were determined.

Like the lines drawing, the planking model was of the port side. For ease of construction, paper was used rather than wood. Illustration board 2 mm. thick was used for the body stations, posts and keelplank, while poster board 1 mm. thick was used for the planking. The model was built on its side to facilitate planking the bottom without rotating the model to complete the sides.

A board, made of a composite laminate to avoid warping, was used as the model's base. The keelplank, rather than being an exact model, was simply a piece of the illustration board glued onto the base along a straight line. The posts were also fastened to the base.

The stations from the lines drawing were redrawn on illustration board. The planking joggles were added to them by adjusting the stations of the stereographic plotting to fit the reconstructed stations. The distances between joggles were maintained while arranging them onto the adjusted curves.

The stations were cut on a band saw, and fastened onto the base with glue. Thus, a series of molds was created exhibiting joggles through at least the sixth strake but no higher than the eighth strake (Fig. 41). The molds extended upwards more than high enough to accommodate any sheer strake.

Rather than fitting the planking through spiling or by

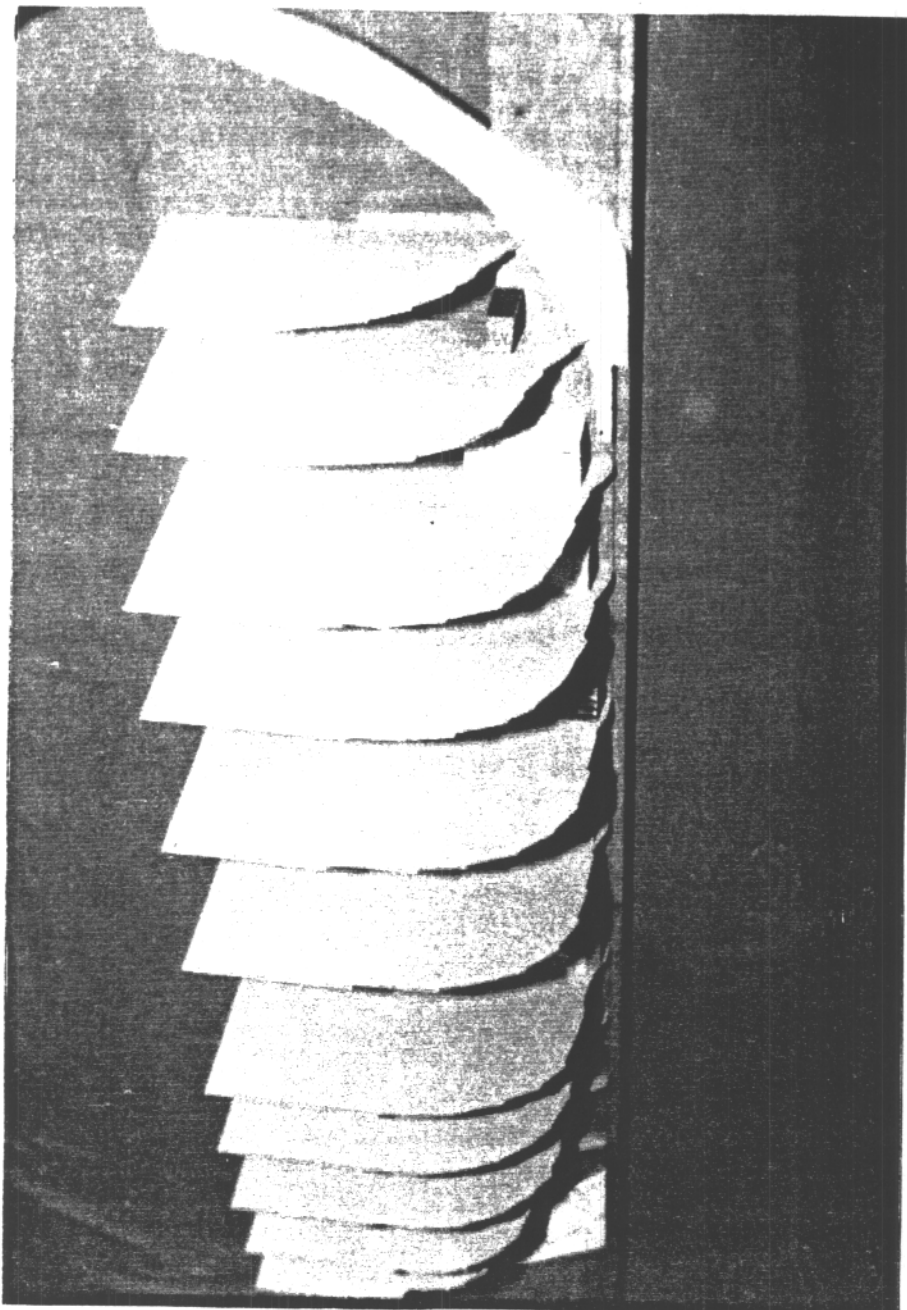

Figure 41. The model before planking.

taking offsets, a short cut was taken. Strips of drafting vellum were held onto the stations while light was projected from the inside of the model. The shadows of the keelplank, or the previous strake as the case may be, and the joggles demarcating the upper limit of the plank could be seen on the front of the paper. These shadows were marked on the vellum, which was then removed from the model. Curves were drawn through the points representing the joggles and keelplank or strake. In this way, a rough plank was drawn. The vellum plank was then cut out and traced on the poster board. The poster board plank was then cut and checked for a proper fit in the joggles. If needed, corrections to the shape of the plank were made and often a new plank had to be cut. When in final acceptable form, the plank was attached to the posts and stations with either glue or double-sided cellophane tape. The planks were scarfed to each other to form the strakes. The scarfs were fastened with double-sided cellophane tape.

This method created strakes without the landings for ease of construction. The overlaps were later added in the planking diagram.

Since the plank extremities were no longer extant above the second strake in the bow and the third strake in the stern, they were reconstructed by extending the curves of

the planks before they were cut. Some of the joggles in the stem's rabbet were evident and the hood ends could be determined from these. However, the joggles on the post were not recorded. Indeed, with the original extent of the post unknown, it was impossible to ascertain the run of the strakes with regard to available space on the post, as could be done on the stem.

While reconstructing the aftmost planks, it was found that their stern ends became considerably narrow. The stern ends of the garboard and second strake were as wide or wider than the rest of their lengths, but above these, the planking widths decreased significantly. There was no way of ascertaining if all the vanished stern hood ends were narrow or if some were wider. Therefore, in order to keep within minimal reconstruction parameters, they were reconstructed with similar widths as much as the lines of each strake would allow. The result was that the third through fifth hood ends are similar in width, and the sixth through eighth hood ends are similar.

This decision was supported by the construction of the vessel. Narrow planking could be expected due to the shape of the stern: "Planks at the comparatively flat side and bottom amidships will be wider than those at the bilge, tuck or other sharper turns of section which

require narrow planks to fit round the shape" (Leather, 1973: 76). Amidships, the planks were wide, so it was logical that they would be narrow in the sharply cut stern.

The decision to make the aft hood ends narrow made necessary the curving forward face of the post, since a straight face would have made the upper planks wider. Thus, the earlier decision to reconstruct the post with a concave face was reinforced by the planking.

While planking the model, it was discovered that some of the joggles shown by the stereographic plottings could not be correct. Without minor adjustments, they would have imposed wildly curving planking at some sections, which would have been in disagreement with the run of the strakes seen in the stereophotograph of the planking (Fig. 8). Consequently, these joggles were shifted by either widening or narrowing a plank at the point of difficulty. Indeed, one mold, number 4, had to have all of its joggles shifted upward along the curve 2 to 3 mm. (equal to 4 to 6 cm. in full scale).

The concept that one strake influences each subsequent strake was used to determine the nearly completely reconstructed forms of the eighth and ninth port strakes. Once the garboard had been fastened to the model, the shape of the subsequent strakes was influenced by the

garboard. Thus, when the seventh strake was set in place, its shape had already been influenced by six other strakes. Further, the eighth strake was based on the shape of the seventh strake, and the ninth strake on the eighth.

The height of the sheer at station 8 was known from the futtock of the starboard central rider beam. This rider beam also had the joggle of the landing of the last two strakes. A flexible curve was used to determine the lay of the eighth strake between this point and the joggle in the stem's rabbet. The same was done in the stern using the pre-determined width of its hood end. The strake was then drawn, cut and mounted on the model.

When the eighth strake was in place the ninth, or sheer strake was similarly designed and mounted. The completed model is presented in Fig. 42. Offsets were taken from the model, and the sheer line was plotted on the lines drawing, which was then completed. The result is presented in Fig. 43.

### The Planking

The plan of the reconstructed planking is presented in Fig. 44. The planking diagram represents the inside of the vessel with the port side featured. Additionally, the end plan depicts the strake landings which are based

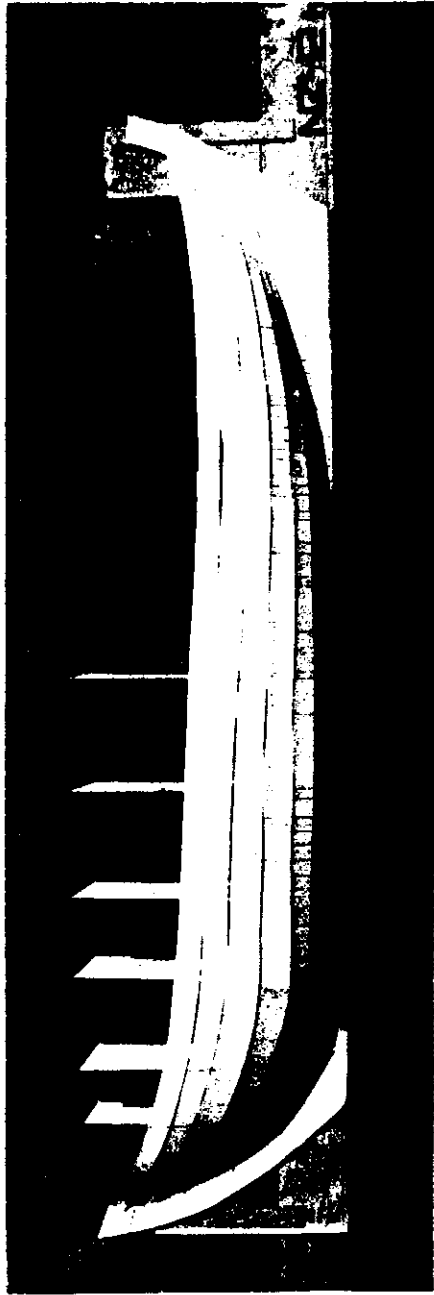

Figure 42. The completed planking model of NZ421.

WATERSCHIP NZ421

LENGTH= 17.28 m.

WIDTH= 5.02 m.

DEPTH OF HOLD= 1.98 m.

LENGTH TO BEAM RATIO= 3.44:1

DRAWN TO THE INSIDE CORNERS  
OF THE LANDINGS

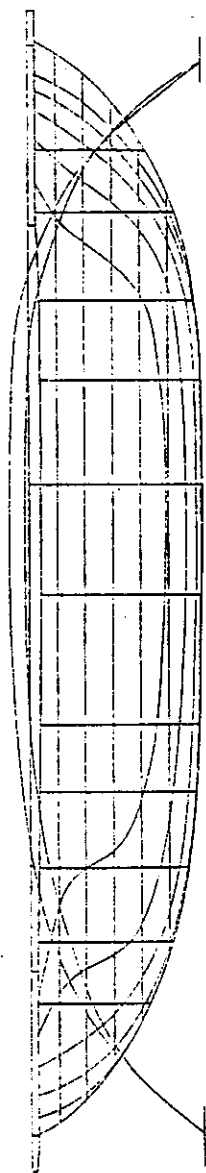

1 2 3 4 5 6 7 8 9 10 11 12 13

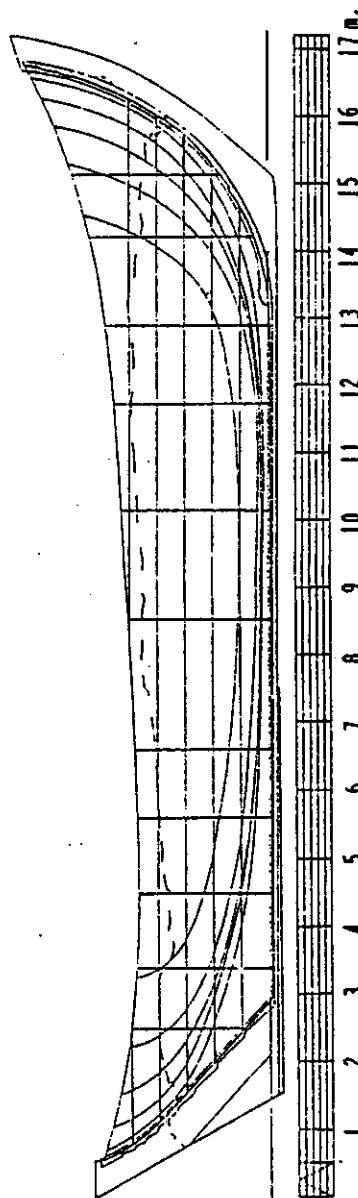

1 2 3 4 5 6 7 8 9 10 11 12 13 14 15 16 17 m.

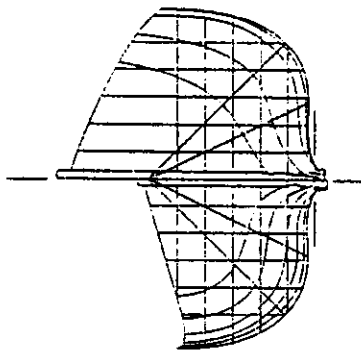

Figure 43. Lines drawing of NZ421.

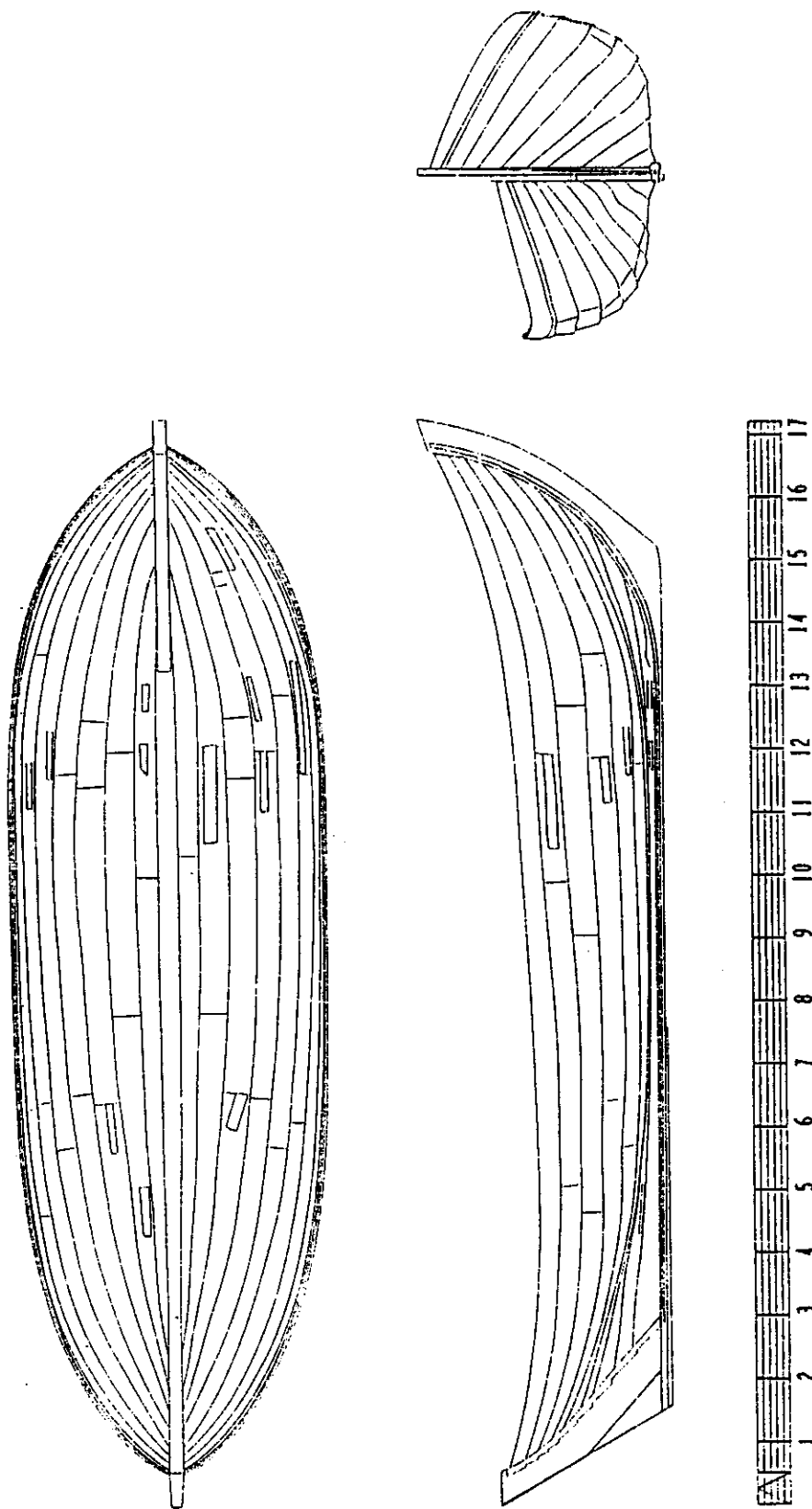

Figure 44. The reconstructed planking of NZ421. Inside port is featured in the sheer plan. Outside port is shown in the end plan.

on excavation drawings. The repair patches and the scarfs were taken from the stereographic plottings of the body and sheer plans. The end plan was created by using the reconstructed sections.

The wale was drawn based on information seen in excavation sketches of a plank overlapping the fragments of the ninth strake in the few areas where it survived. From the drawings it was apparent that the only wale on the vessel was this doubled plank.

#### The Shape of the Vessel

The low, sleek stern is a counterpoint to the high, bluff bow. Near the keelplank in the stern, the steep angle of the garboards makes the area knife-like. The next strake also exhibits this steepness but above it the hull curves outward. The sharp tuck between the second and third strakes gives the stern a wine-glass shape.

The curving inner line of the post made the stern deck wider than it would have been if this line had been straight. Thus, the curving post not only made the stern lower by narrowing the planking but also made the deck a better working space for the fishermen and the helmsman.

While the after part of the sheer strake is narrow, the forward part displays the broadness of the other strakes in the bow. The wide strakes make the bow broad and high

in the manner of many ship types of the North sea area. The design is well suited for deflecting waves and spray, and through its great displacement, the bow aided in lifting the vessel over waves.

The central section of the vessel has slightly curved sides and a flat bottom which makes it box-like. Indeed, the bottom is actually horizontal at the second and third strakes. Thus, the bilge is most pronounced amidships. Towards either end, however, the turn of the bilge becomes less pronounced as the amount of deadrise increases.

The shape of the reconstructed vessel is in agreement with other waterschepen and waterschip models. In 1614, the waterschip was described as having a broad, flat bottom in the middle of which was an area with small holes for the holding of fish (van Beylan, 1970: 150). Crone described waterschepen as completely decked keel ships, with a cabin aft of the mast, a full bow with a steep stem, and in the aft finely cut (Crone, 1926: 239). In various artistic representations, such as Figs 45 and 46, the waterschip is seen as having a full bow with a high, slightly bent stem and a low stern (van Beylan, 1970: 150).

The form of NZ421, and waterschepen in general, was determined not only by environmental and functional

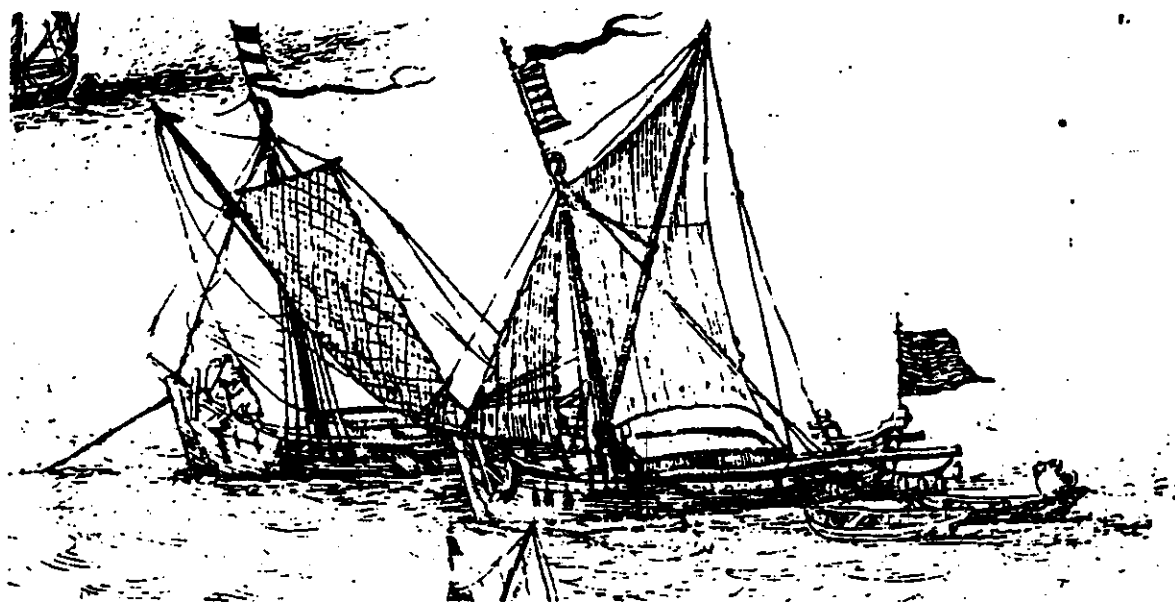

Figure 45. The waterschip as depicted by B. Florisz from his map "Kaart van Amsterdam," 1625 (courtesy of Gemeentelijke Archiefdienst van Amsterdam).

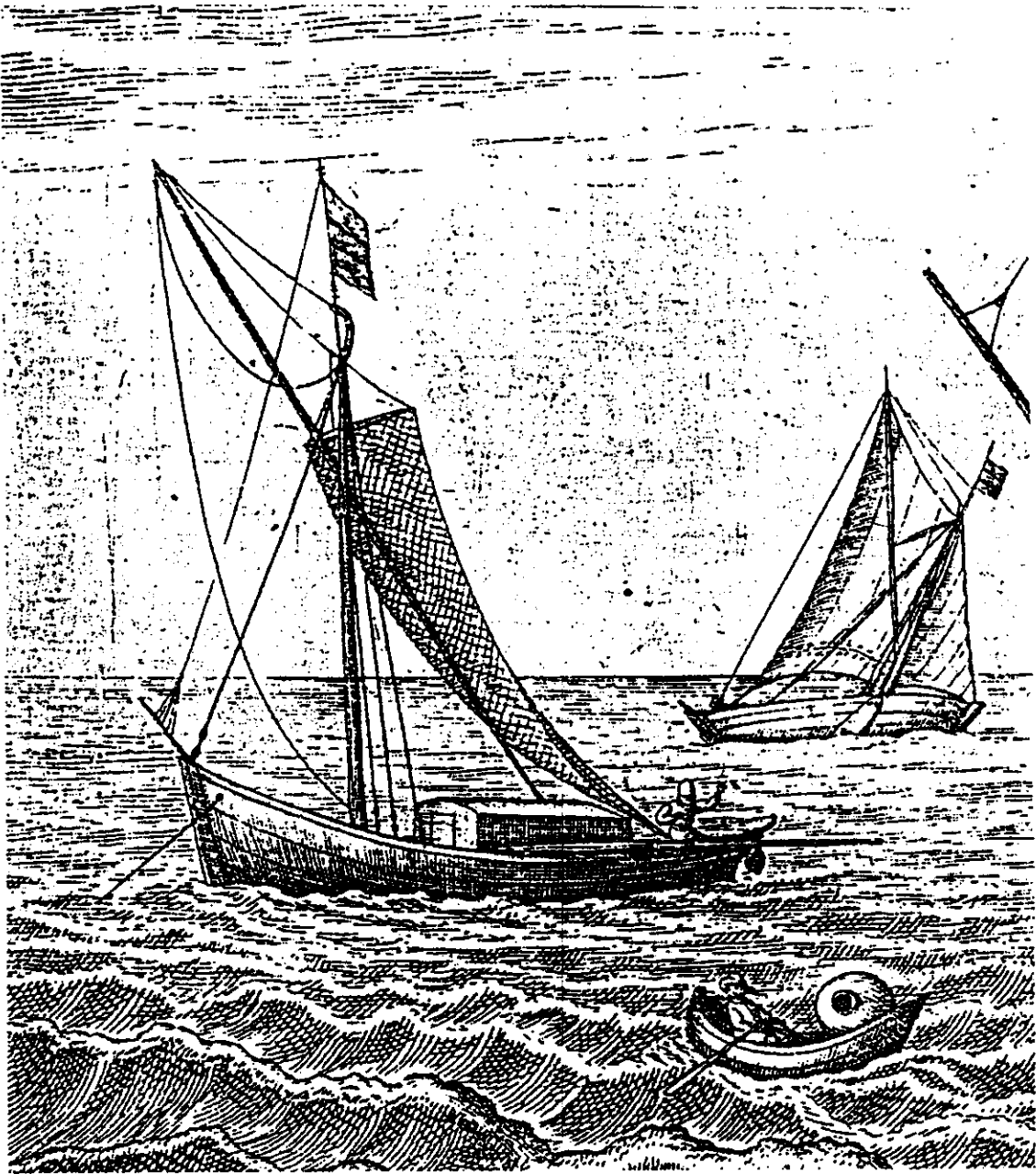

Figure 46. An anonymous engraving of a waterschip from 1600 (courtesy of Rijksmuseum, Amsterdam).

factors but by economic ones as well. As is readily seen in the lines drawing, NZ421 is beamiest at the forward bulkhead. The broadness of the fishwell along with the small deadrise increased its volume and therefore its profitability. However, this construction created some planking problems, since the strakes had to be brought into the stem from this wide point. Turning them toward the stem was accomplished through the use of scarfs which can be seen clustered on the second, third and fourth strakes in front of the bulkhead on both sides of the vessel (Fig. 44). A similar clustering of scarfs is found aft of the fishwell.

#### The Framing (Fig. 47)

With the shape and the planking of the vessel reconstructed, the proper placement of the framing could be decided. This was achieved through several methods including drawing the framing onto the model; using the stereographic plotting of the framing plan, which was the only record of the placement of the frames; and using a flexible paper model. No details on the planking relevant to the placement of frames were recorded aside from that which was visible in the photographs and the stereographic plotting. The arrangement of the floor timbers along the keelplank was taken from the plotting

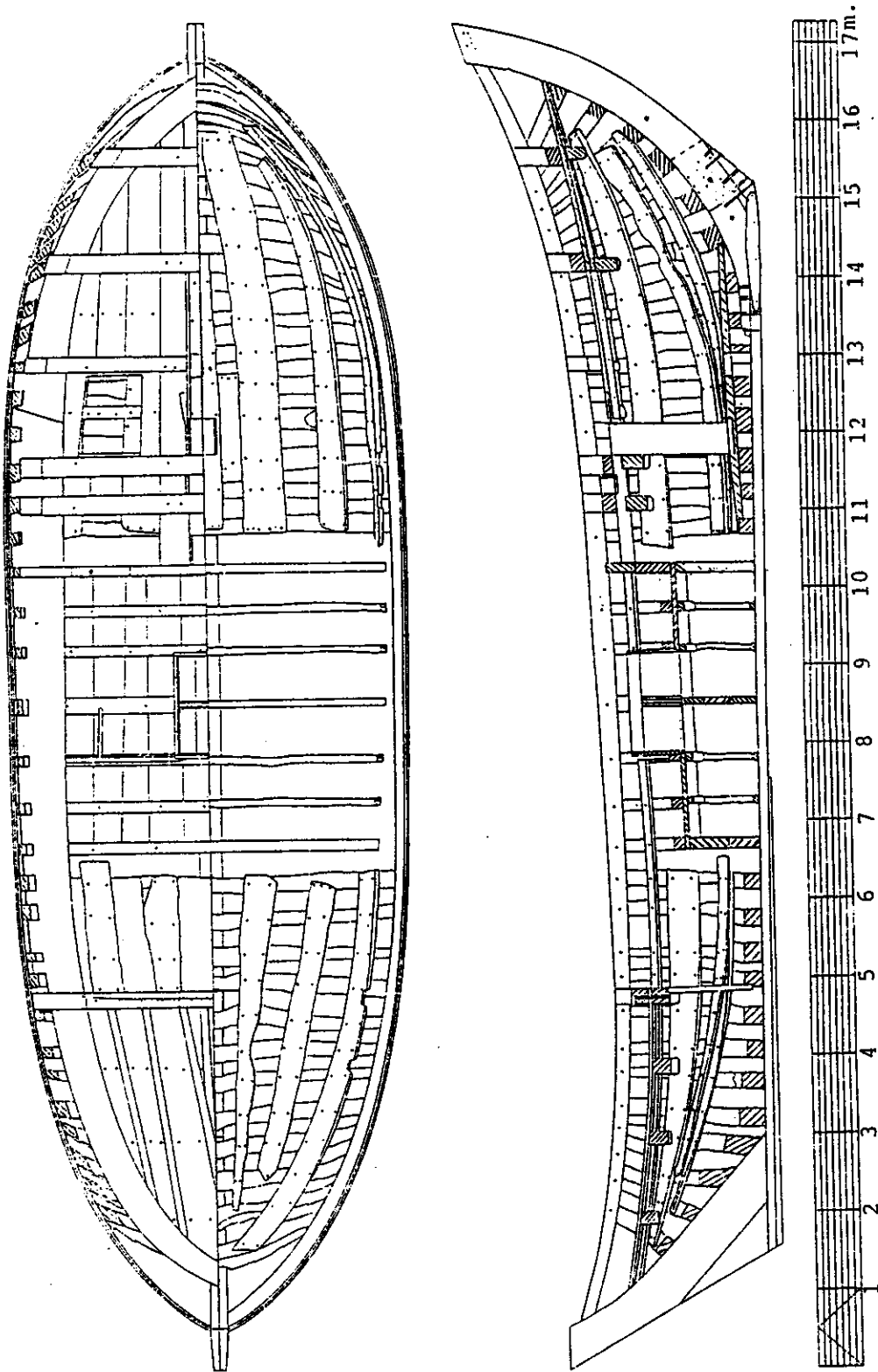

Figure 47. The reconstructed framing of NZ421.

with no modification.

The higher framing members and the frames on the posts were either distorted or no longer extant. The only data for the vanished timbers were photographic, such as the treenails visible in the planking for frame 15. However, there were no details visible for the correct placement of the frame tops which had bent outward with the planking.

Being better preserved, the framing on the port side was reconstructed first, since it would be easier to recreate the framing on the starboard side using the port side as a model.

The framing in the bow was recreated in a model made of vellum in order to determine more precisely the original shapes of these timbers. The model was made of frames I through M and of the forward stringers. The paper frames and stringers were fastened together with small staples, giving each juncture the ability to move around the fastenings. The model was laid over the stereographic plotting of the frames, and was bent upward into the reconstructed shape of the bow. Bending the vellum frames in this manner moved the frame tops towards their pre-wreck positions. This method also found the original positions of the forward ends of the stringers.

Missing frames were added to fill in open spaces. Bow

frames were added to fill the empty space between frame M and the assumed deck level. The placement of frames O through Q was based on the distances between frames L and M and frames M and N.

The reconstruction of the stern framing was simpler than the bow, since only the aftermost frames appeared to have much distortion. Frames 4 through 11 simply needed to be extended to the sheer. The other frames were straightened and extended to the sheer line, which resulted in their tops moving forward of their positions in the wreck.

As stated above, the existence and location of frame 15 was indicated by the treenails in the planking aft of frame 14; they can be seen in Figs 8 and 23. These treenails were arranged in a line from the post towards the sheer and could only have been for the fastening of a frame. Since no further evidence for additional framing was present, it was decided not to add more frames until the level of the stern deck was ascertained. This ultimately demonstrated that there were no frames aft of frame 15.

The fishwell framing needed no reconstruction since their positions had been virtually unaffected. Likewise, the bulkheads needed no reconstruction. However, the two timbers above the forward bulkhead needed their starboard

ends reconstructed. Like other components of the vessel, these were made to resemble their port sides. This was particularly important in regards to the timber overlaying the waterway and kingplanks, since its reduced height on its port side was apparently to allow for easier passage along the waterway/gangway. Likewise, its diminished middle section was probably for easier access between the higher forward deck and the lower fishwell deck.

## The Stringers

### Bow Stringers

As mentioned above, the paper framing model also aided in determining the correct placement of the extremities of the stringers. The bottom stringers were in their original positions for the most part but their forward ends had vanished. However, the remains of the bilge stringers had bent outward with the sides of the wreck when the bow structure disintegrated. Likewise the shelves had not survived intact. The starboard shelf had completely vanished but most of the port shelf survived, although its forward half had splayed outward. Also, there is evidence that the port shelf was not found in its original position but had fallen onto the bilge stringer. This can be seen through a comparison of Figs

16 and 37. In the latter figure, the shelf is almost resting on the upper edge of the bilge stringer, while Fig. 16 shows the shelf in a different position.

Apparently, it had been placed in its higher position by the excavators, and this position cannot therefore be considered as reliable evidence.

In the reconstruction, the forward ends of the port bilge stringer and the shelf were bent towards the vessel's centerline in agreement with the hull shape. The stringers were extended towards the stem in a fair curve in a way similar to that used to reconstruct the planking at the ends. The reconstructed shelf and bilge stringer touched at frame 0 but did not come into contact with the bottom stringer.

Although the shelf's after end was below the landing of the seventh and eighth strakes, as specified in the excavation report, halfway along its length it began to curve upward. This curve ultimately produced a curving deck, but due to the widths of the stringers underneath, this deck's curvature could not be reduced.

Until the level of the forward deck could be determined, the shelf's forward extremity could not be reconstructed. The lengths of the other bow stringers also depended on the deck level, although it appeared that the port bottom stringer survived over almost its

entire length. The bilge stringer was also probably not much longer than as preserved. Thus, the bottom stringer was ended at frame P and the bilge stringer at frame O.

### The Stern Stringers

In the stern, with the exception of the starboard shelf which had completely vanished, the other stringers survived over part or most of their lengths, and needed little reconstruction. The bottom stringers were extended from frame 12 to frame 14, and the width of the one on the port side was increased at some points since it appeared to be somewhat degraded. The port bilge stringer was extended from frame 10 to frame 13, since the corresponding starboard stringer reached to frame 13. The bilge stringers could not have been longer, since the reconstructed port shelf and bilge stringer meet at frame 13.

The port shelf did not survive past frame 12. It was necessary to extend this towards the post in order to provide support for the beams. However, the stern deck had to be reconstructed before the length of the shelf could be established.

### The Decks

The stereophotograph of the decks (Fig. 3) was used

extensively in their reconstruction, although other photographs and the excavation notes were also used. Reliable descriptions and dimensions of many of the deck timbers and fastenings made possible accurate reconstruction.

### The Forward Deck

Using the information presented in the previous chapter, the reconstruction of the forward deck was uncomplicated. Although data regarding the camber of the beams and the notching of the beam ends was not recorded, these were reconstructed based on the placement of the deck above the keelplank.

While an overall width of the forward deck was never presented, a combination of various measurements determined its width. The port kingplank was 40 cm. wide aft and approximately 30 cm. wide at the third deck beam/rider beam assemblage, as based on excavation sketches. At the forward face of the second deck beam/rider beam assemblage, the kingplanks were 40 cm. apart and at the third deck beam 36 cm. apart. Thus, assuming each kingplank was equidistant from the centerline, it was possible to place the timbers along it. Using the widths of the deck planks at the first full beam (p. 65), the deck was filled out to the inner

edge of the waterway, with the run of the decking taken from Fig. 3. The waterway was drawn using measurements given at the forward bulkhead, 51 cm., and aft of the third full beam/rider beam, 40 cm. By joining these two points with a fair curve the outer edge of the waterway was determined. Thus, it only remained to extend the waterway to the stem.

Considering that either side of the vessel was a near doppelganger of the other, the starboard forward deck was most likely a close mirror image of the port side, with or without the hatch. Likewise, the starboard ends of the rider beams were reconstructed as integral, vertical knees, although they may have been scarfed onto the timbers like the ones on the fishwell deck.

The height of the deck was dependent on unrecorded factors such as the molded dimensions of the futtocks, which would affect how low the deck could have been set; and the amount of camber to the beams, since more camber would raise the deck in its center. While this would not affect the after ends of the kingplanks which rested on the bulkhead, the camber affected the height of the forward ends. Since the juncture of the deck and stem had not survived, no clues for this were forthcoming. Additionally, the depth to which the beams had sat in the notches on the shelves was unknown.

Ultimately, it was decided to set the deck at a level where the rail would be high enough to protect the vessel and crew but not so high as to impede the hauling of nets from the sea. Thus, the height was set by intuition. This solution also allowed the kingplanks to rest on frame Q. Since the surviving length of the port kingplank intersects the reconstructed waterway, the kingplanks served to connect the waterway to frame Q, albeit indirectly, as well as to support the forward ends of the waterways.

The connection between frame Q, the kingplanks and the waterway gave the necessary support to the forward end of the deck as well as tying the stem via these timbers to the bulkhead. The resultant deck position (Fig. 47) then permitted the reconstruction of the full and half beams.

#### The Fishwell Deck

Decking widths taken from the stereophotograph (Fig. 3) were used in reconstructing the fishwell deck. Photographic distortion resulting from the wreck's list to port had to be taken into account (p. 90). Through a comparison of dimensions in the notes for the waterway/gangway with the size of the same timber in Fig. 3, the amount of distortion was calculated to be 40 percent. By increasing the widths of the decking on the

port side of the fishwell deck by this amount, a satisfactory reconstruction was achieved.

The shapes of the rider beam ends were ascertained from the course of the waterway/gangway, the height of which was known at the forward bulkhead by the height of that bulkhead. The height of the waterway/gangway through the fishwell section was determined by the landing of the seventh and eighth strakes to which it ran parallel. Thus, the rider beam ends were reconstructed to support the waterway adequately.

The trough needed no reconstruction except for the vertical laths on its inner faces (p. 73). These were drawn as light timbers 2 cm. square in section, to hold a 5 cm. thick cross timber. The dimensions selected were ones which would be large enough to hold a removable partition while not being obstructive. The cross timber, or partition, would have divided the trough into forward and after halves. This was reconstructed as 5 cm. thick, since the builders probably would have used a piece of scrap for this, such as a length of deck planking.

### The Stern Deck

The stern deck was reconstructed by tracing the deck as it appeared in Fig. 3 and retracing this onto the deck plan. Its forward extent was known by the forwardmost

notch in the shelf. However, its position between the vessel's sides needed to be determined. In order to center the deck between the sides of the hull, an arbitrary judgement was made dividing the deck along the juncture of the two planks flanking the stealer and using this as the centerline of the deck. The waterway was extended to the post from the aft bulkhead along both sides. The decking seams were extended until they contacted the waterways thereby filling in the open spaces with reconstructed decking and laths.

The deck's height above the keelplank was determined by a compromise between maintaining a uniform distance between the shelf and waterway and creating a good working platform by reducing the curve of the deck.

The result was a slightly up-curving deck (Fig. 47), the waterways of which ran parallel to the landing of the seventh and eighth strakes for approximately half their lengths. Then, as the curve of this landing increased, the deck followed a less curving course. It was possible to make the waterways follow the landing of the strakes, but this would have created a steeper deck that would have made it difficult for the helmsman to keep a sure footing. Thus, a flatter deck was chosen to avoid problems at the helm.

With the height of the waterway set, the deck beams

could be properly positioned. The cambers and end notches of the beams were reconstructed using sketches of the beams made by the excavators. By examining the stereophotograph of the deck, the locations of treenails holding the deck beams were ascertained. On the basis of this data, the second and third beams were placed 91 cm. apart. and the third and fourth beams 1 m. apart.

### The Sections

The reconstructed sections of NZ42i are presented in Figs 48 through 58. Fig. 59 is the forwardmost stern deck beam. Available excavation drawings of the sections are included with the reconstructed ones for comparative purposes only, since the more accurate stereographic plottings were used for the reconstruction.

In instances where portions of a crooked frame pass entirely outside the sectional plane, the portions are indicated by dotted lines. Fastenings that did not fall directly on the sectional plane were similarly indicated.

### The Steering Arrangement

The only remains of the steering arrangement was a single gudgeon, still in place. There were no traces of other gudgeons on the surviving part of the post. This indicates that one must have been fastened onto the upper

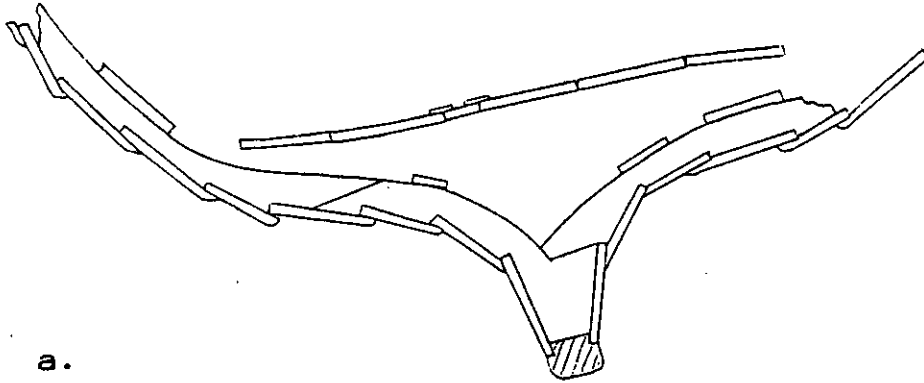

a.

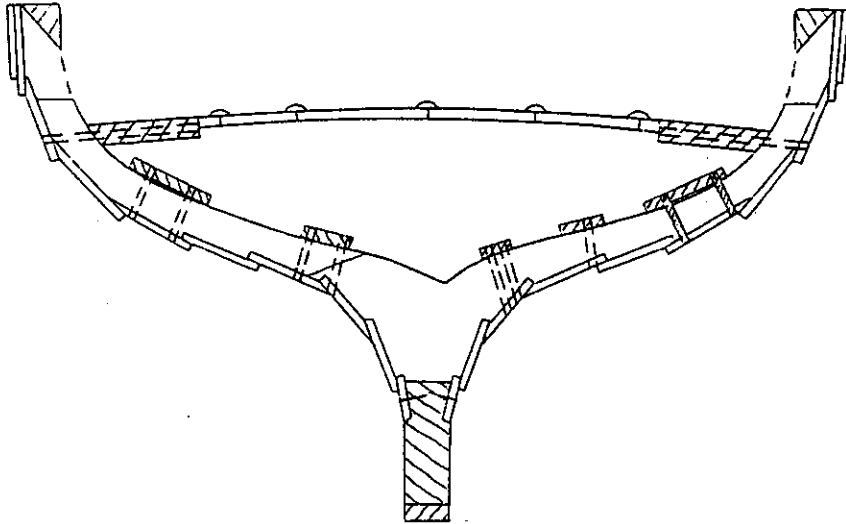

b.

Figure 48. Section 1- a. as found, b. reconstructed.  
(Not to scale).

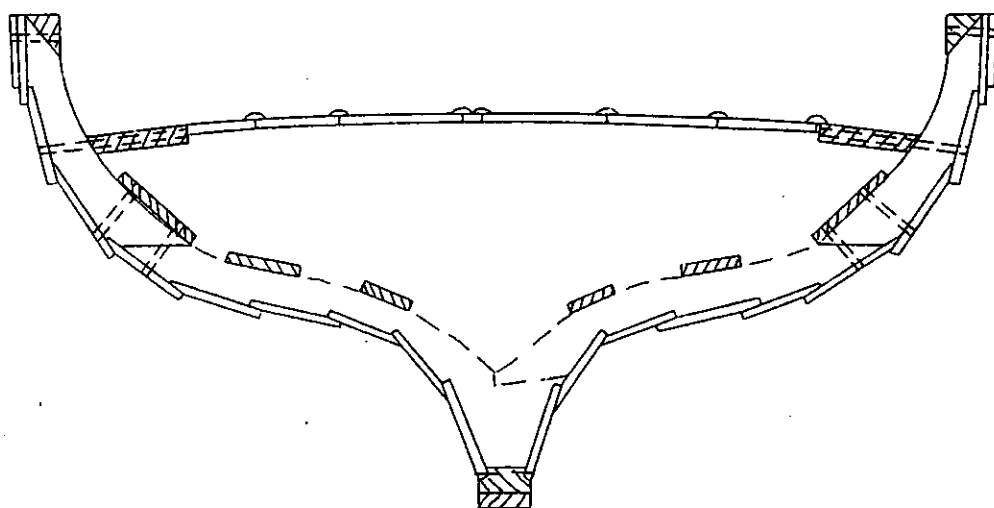

Figure 49. Section 2- reconstructed. (Not to scale).

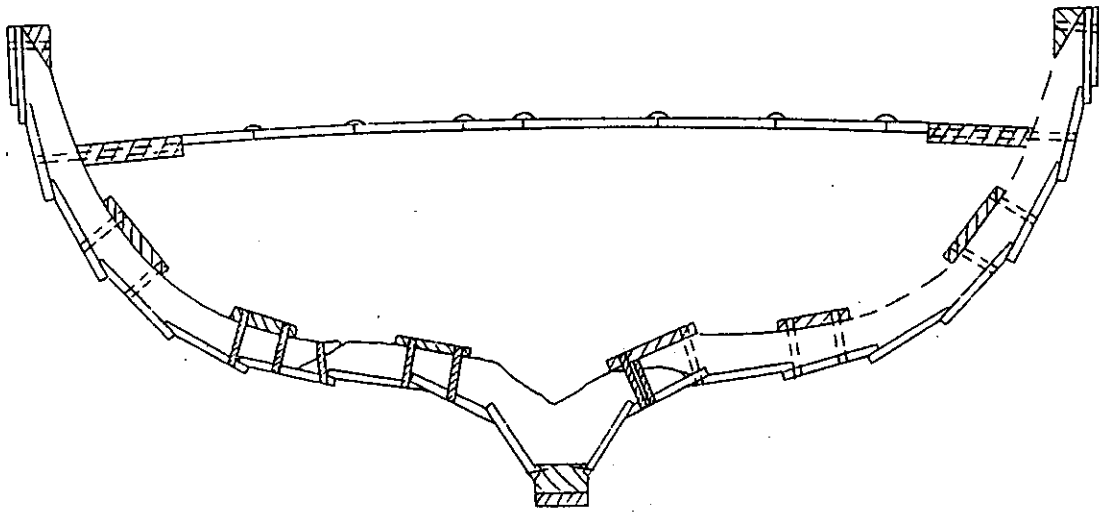

Figure 50. Section 3- reconstructed. (Not to scale).

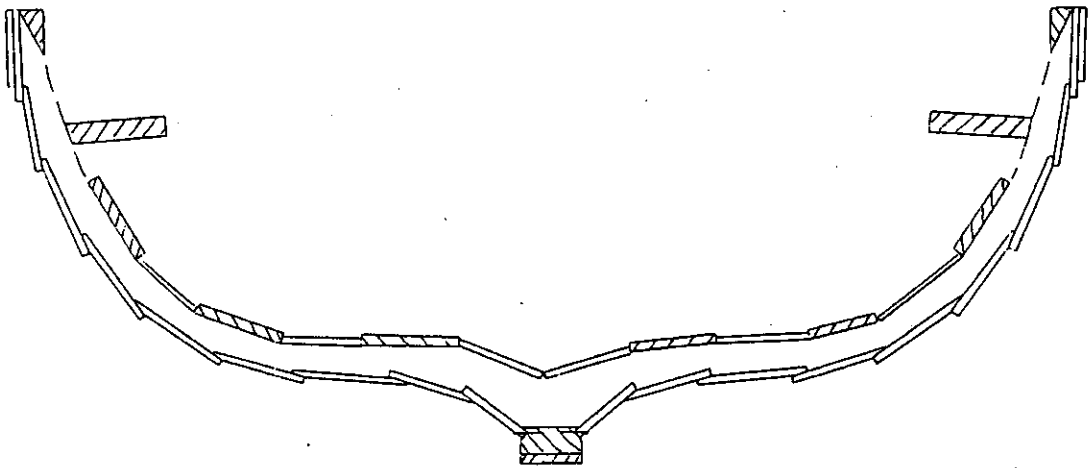
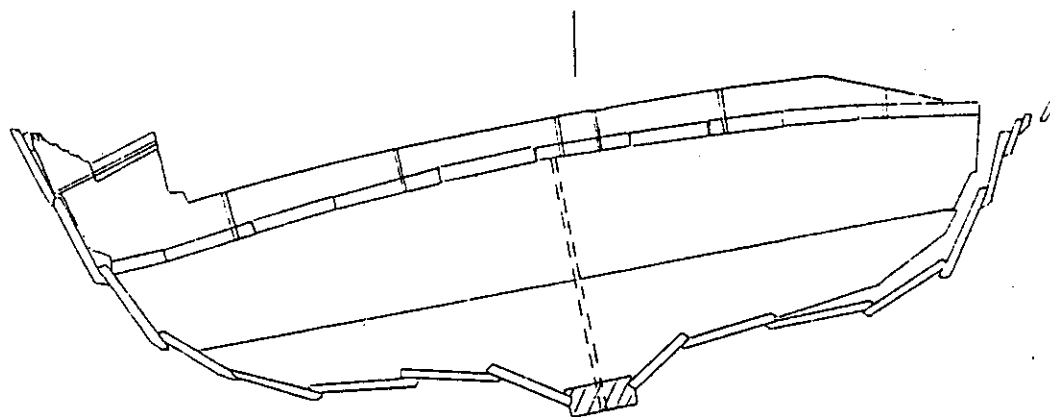
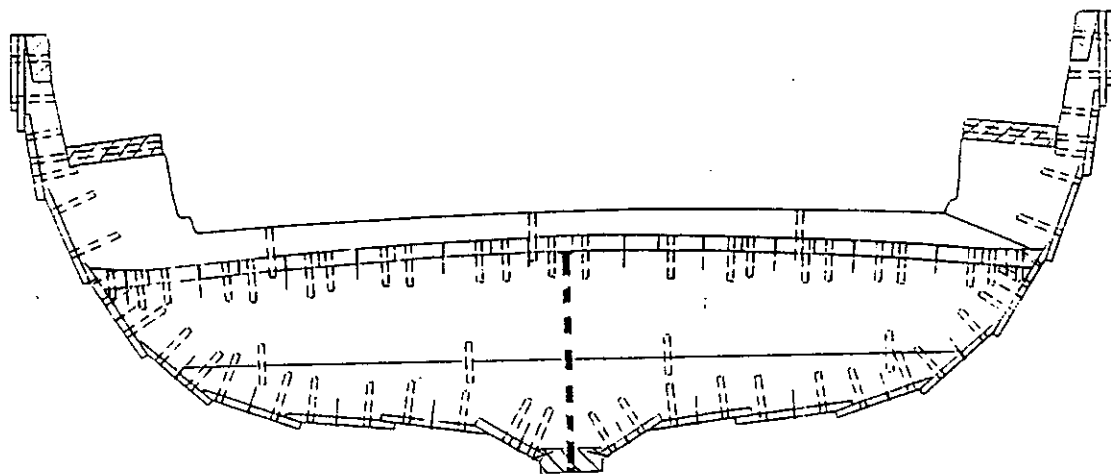

Figure 51. Section 4- reconstructed. (Not to scale).



a.



b.

Figure 52. Section 5- a. as found, b. reconstructed.  
(Not to scale).

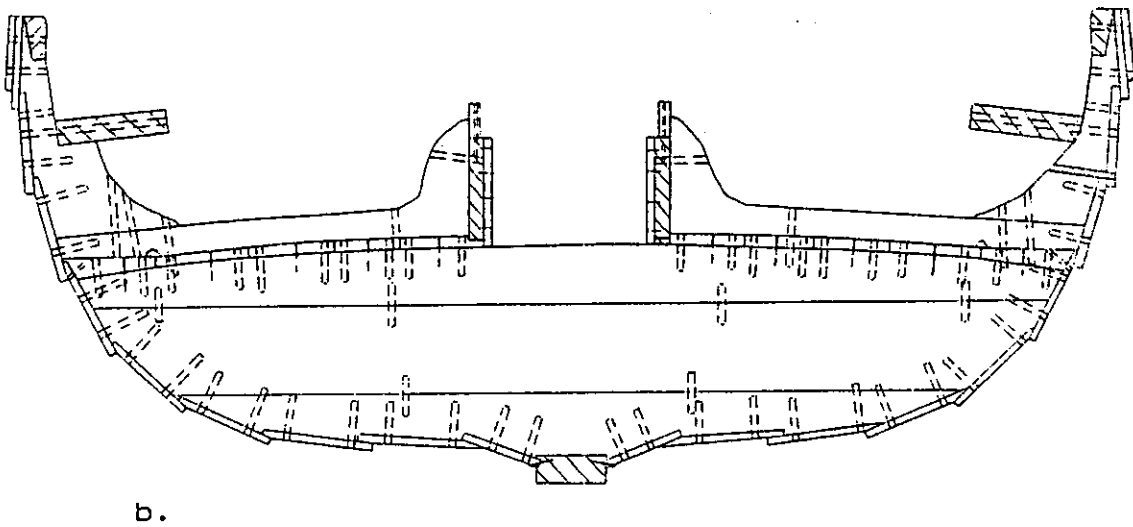
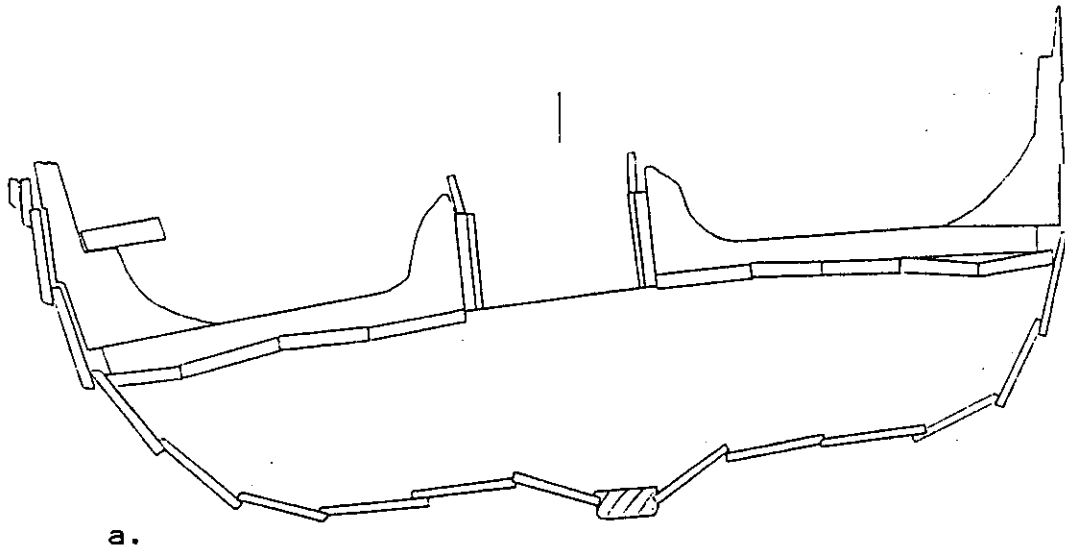
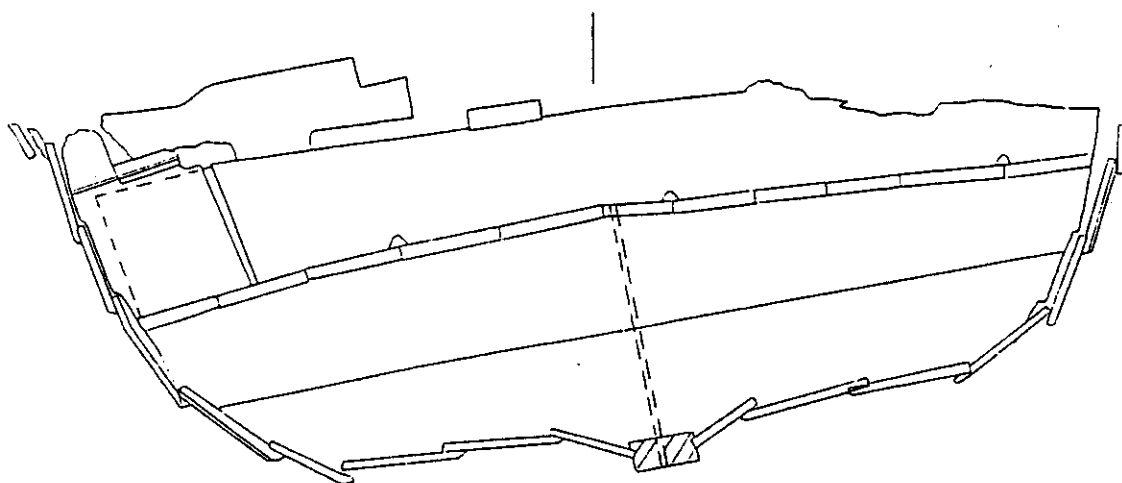
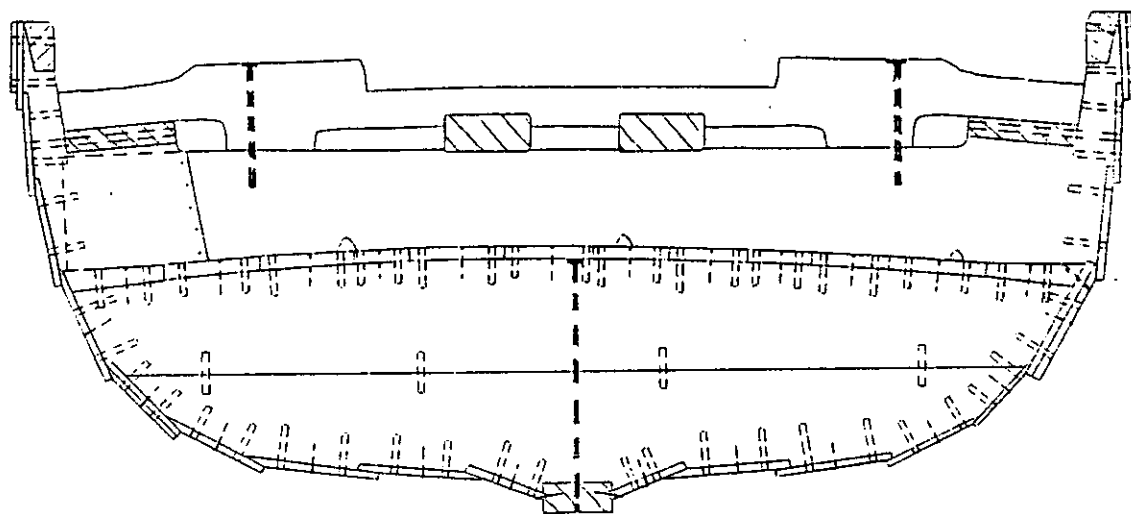

Figure 53. Section 8- a. as found, b. reconstructed.  
(Not to scale).



a.



b.

Figure 54. Section 9- a. as found, b. reconstructed.  
(Not to scale).

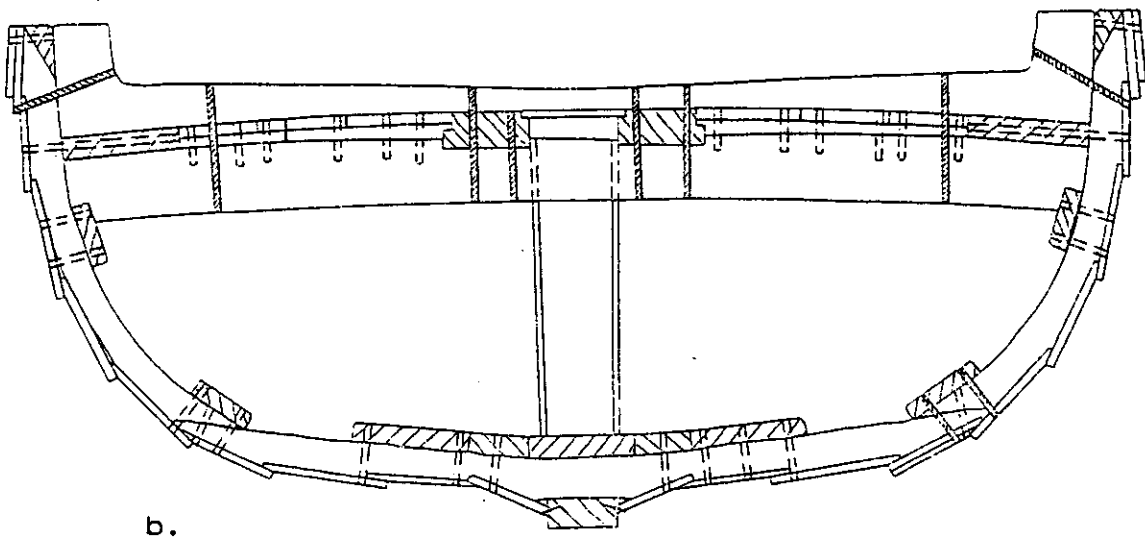
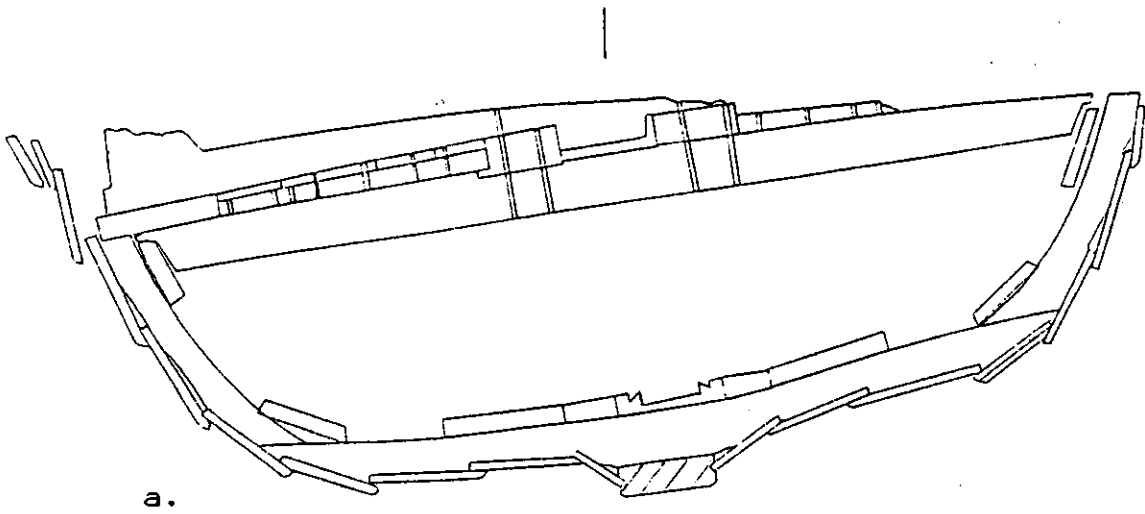
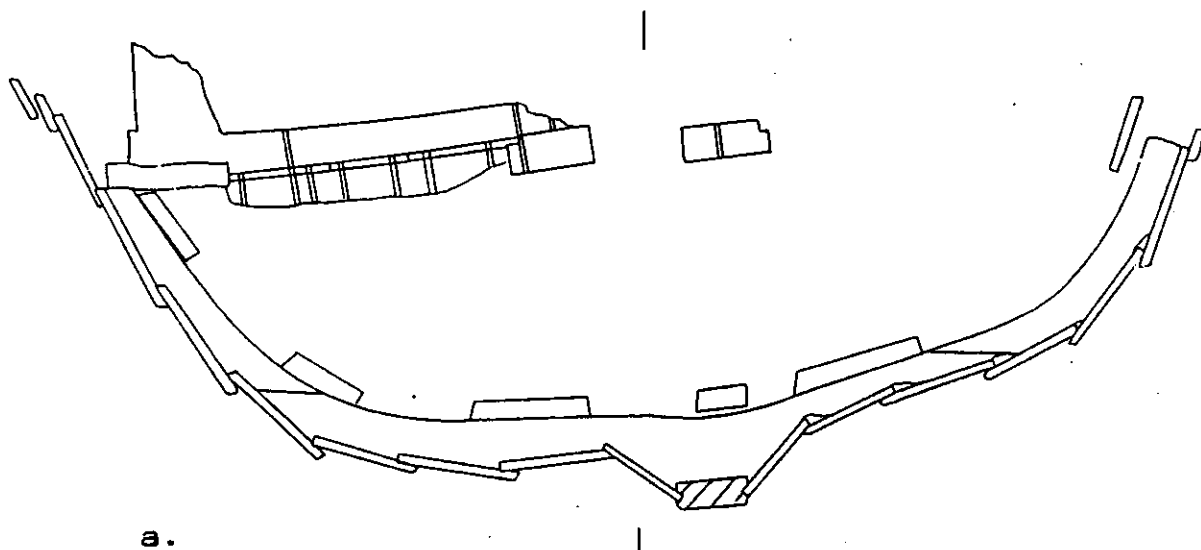
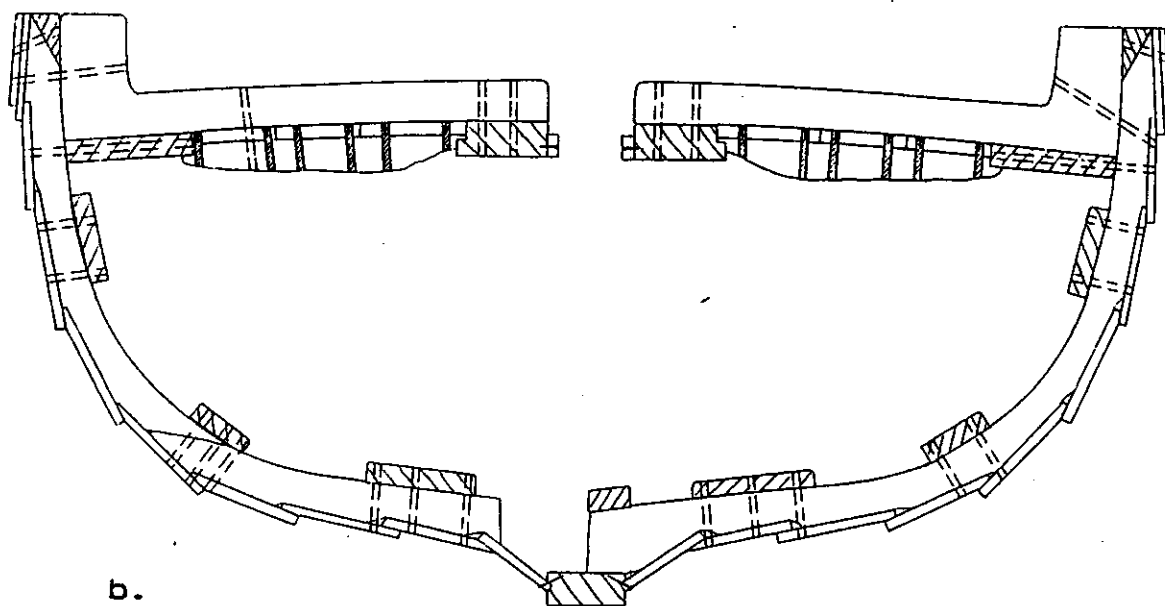

Figure 55. Section 10- a. as found, b. reconstructed.  
(Not to scale).



a.



b.

Figure 56. Section 11- a. as found, b. reconstructed.  
(Not to scale).

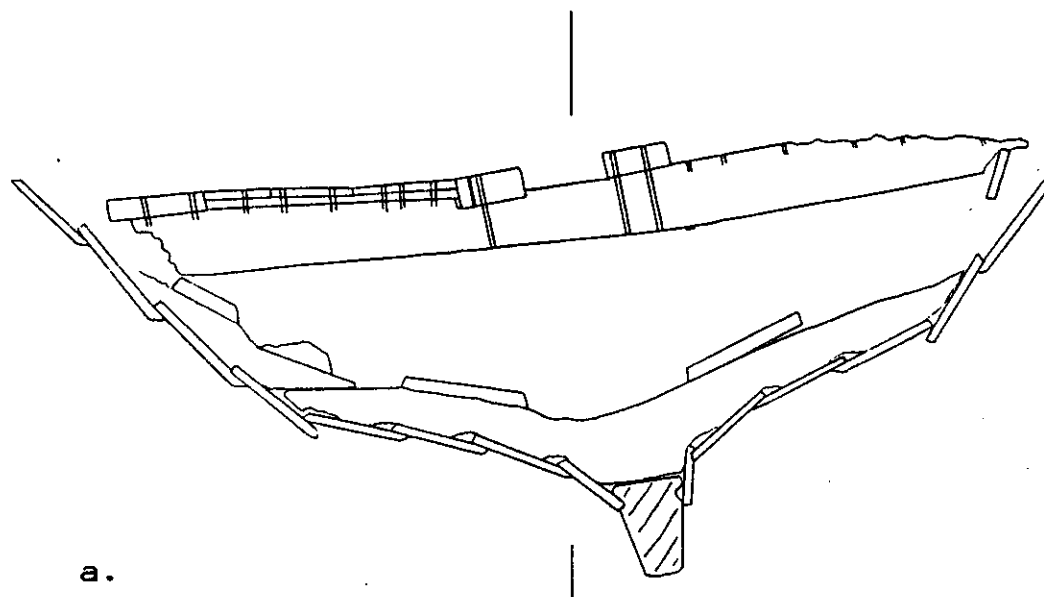

a.

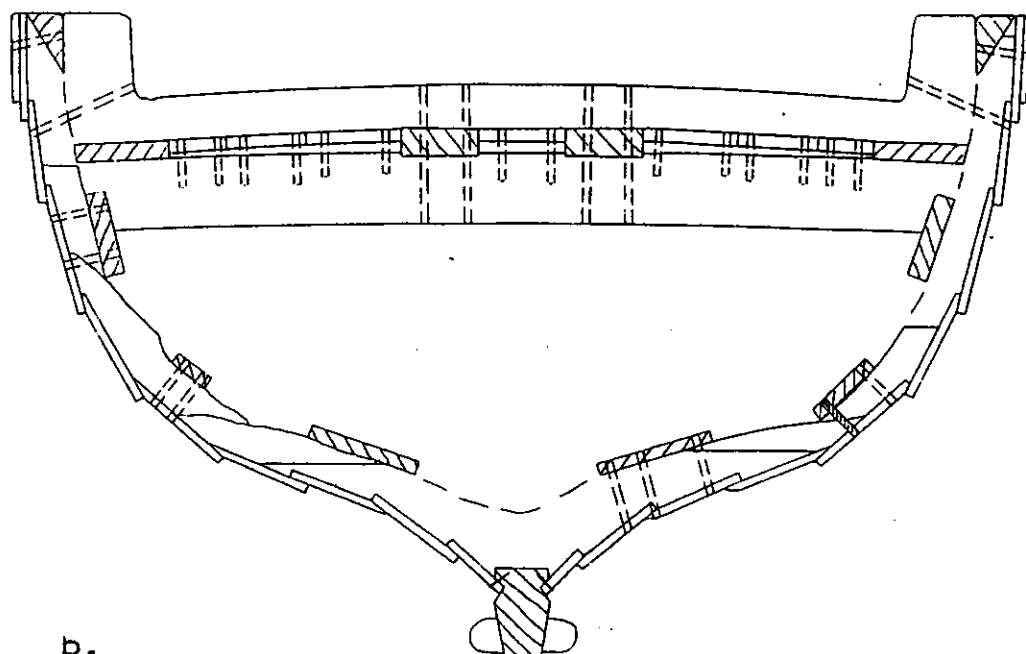

b.

Figure 57. Section 12- a. as found, b. reconstructed.  
(Not to scale).

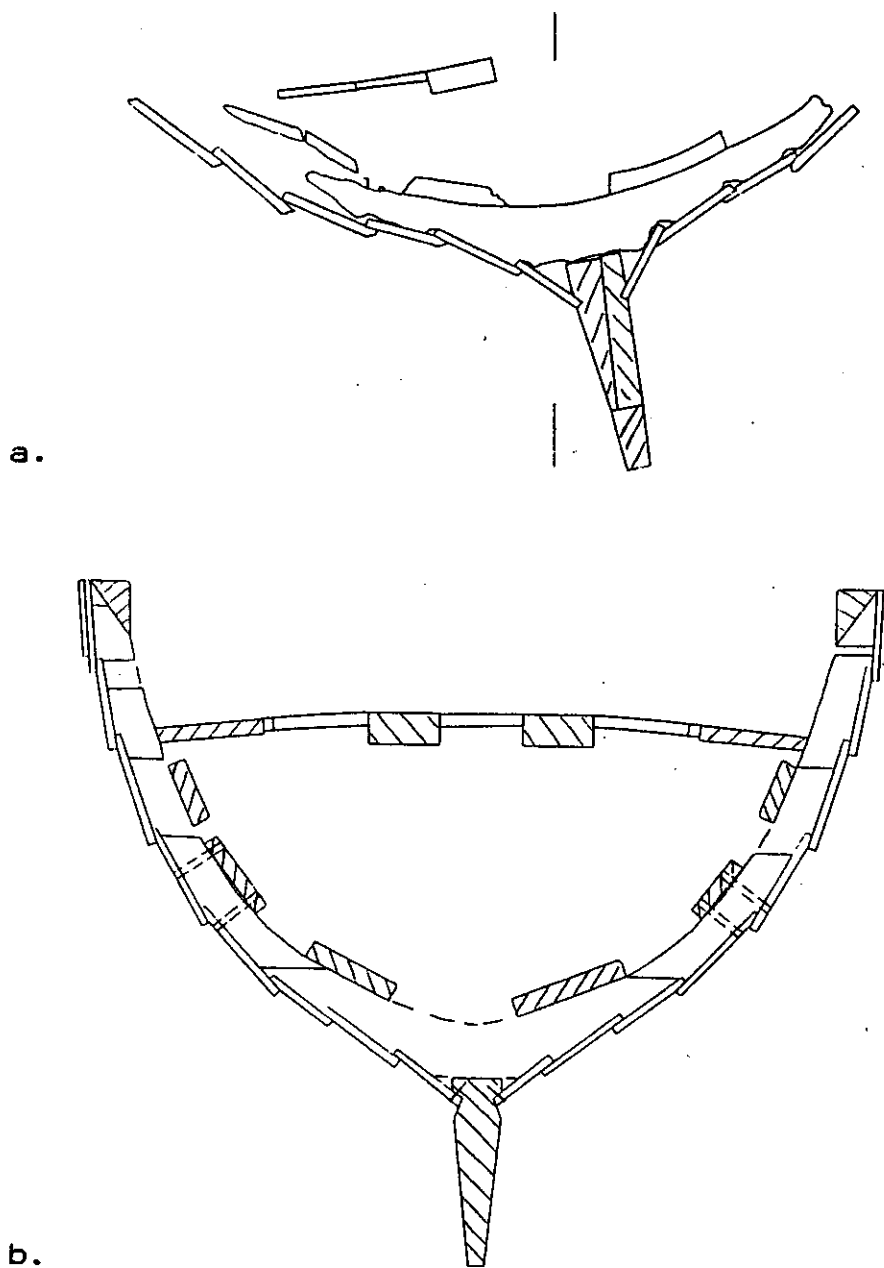

Figure 58. Section 13- a. as found, b. reconstructed.  
(Not to scale).

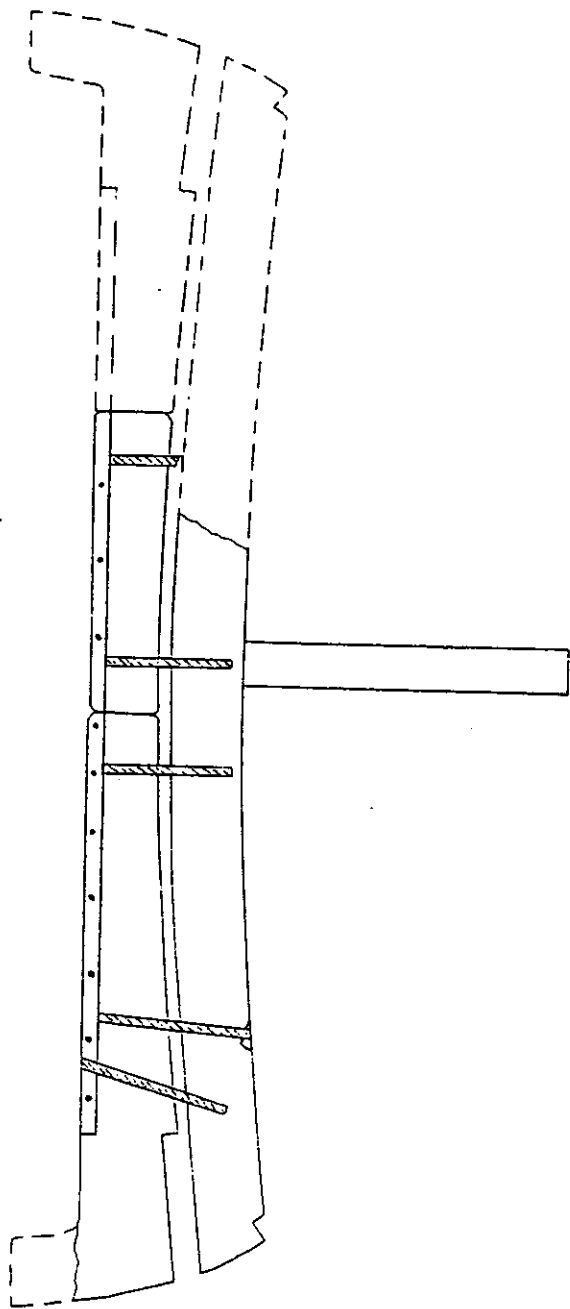

Figure 59. The forwardmost stern deck beam.  
(Not to scale).

part of the post which had vanished.

While the shape of the rudder is a matter of speculation, depictions of waterschepen such as the one by Balthasar Florisz (Fig. 45) show the shape of the tiller. While Florisz' drawing is of a later date, the tiller of NZ42i was probably similar, because the downward curve was needed to enable the helmsman to reach it comfortably.

#### The Mast and Rigging

There is little available evidence for the mast and rigging except for the mast foot, the deadeye found near the second forward deck rider beam and the series of holes near the top of the stem.

The series of five holes at the stem top were for the attachment of a forestay via a deadeye and lanyards. A similar series of holes was found on wreck W10 (Fig. 60), and the lanyards and deadeye can be seen in Fig. 60. This was a characteristic of the waterschepen called the gordijn (= curtain) (Crone, 1926: 242). As can be seen in Figs 45, 62 and 63, a foresail was attached to the forestay.

There was no evidence on NZ42i for the attachment of the lower end of a backstay. The Florisz drawing (Fig. 45) shows backstays attached somewhere in the area of the

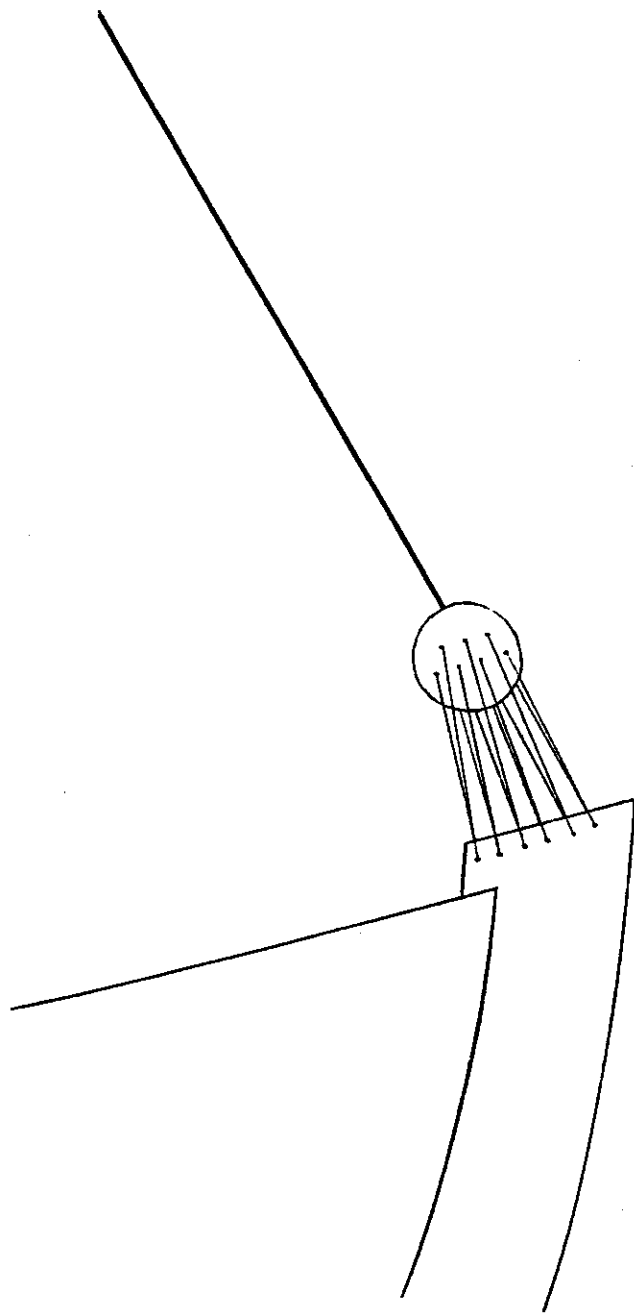

Figure 60. The stem top of W10 (not to scale; after Reinders, 1987: app. 1).

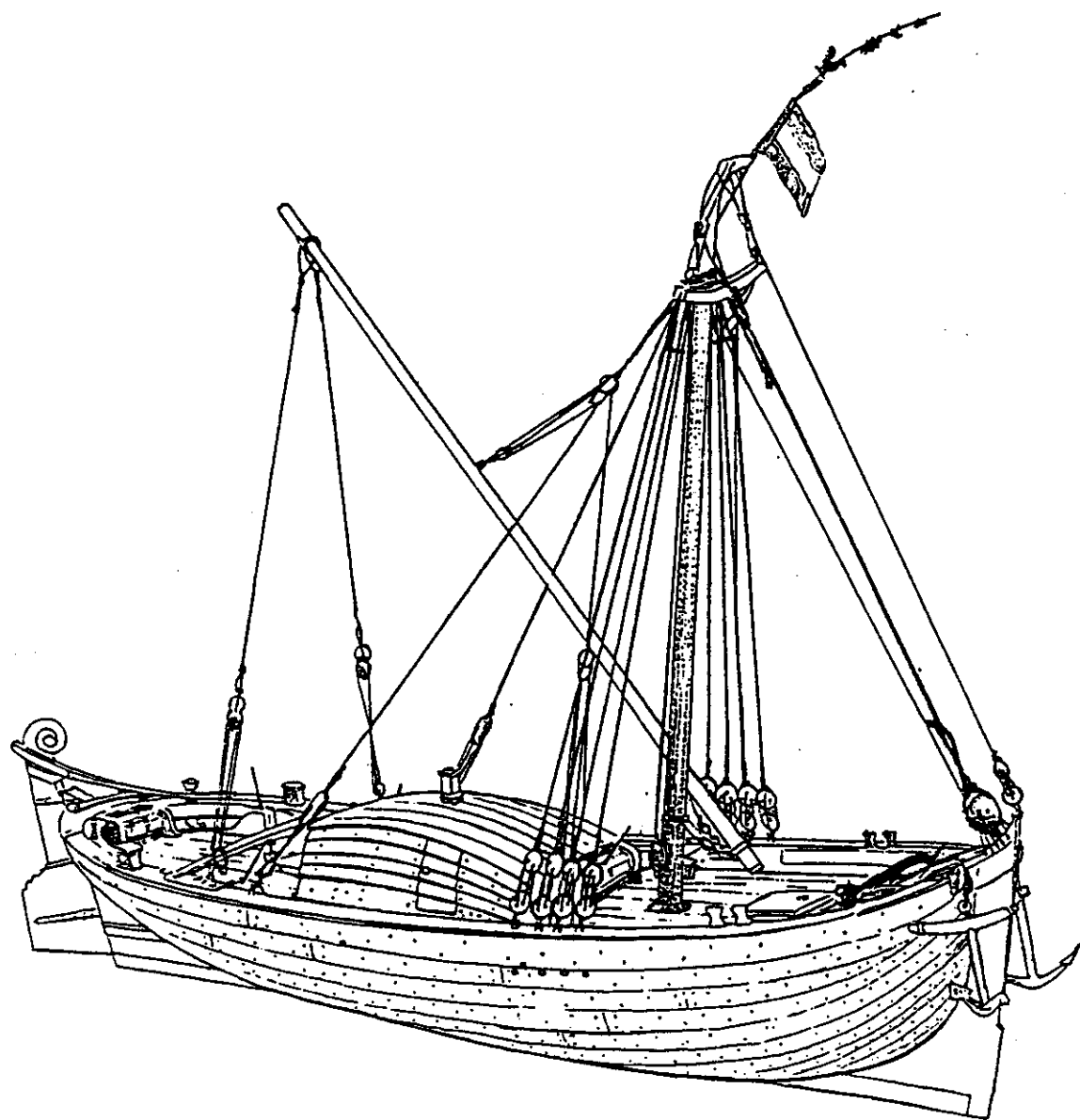
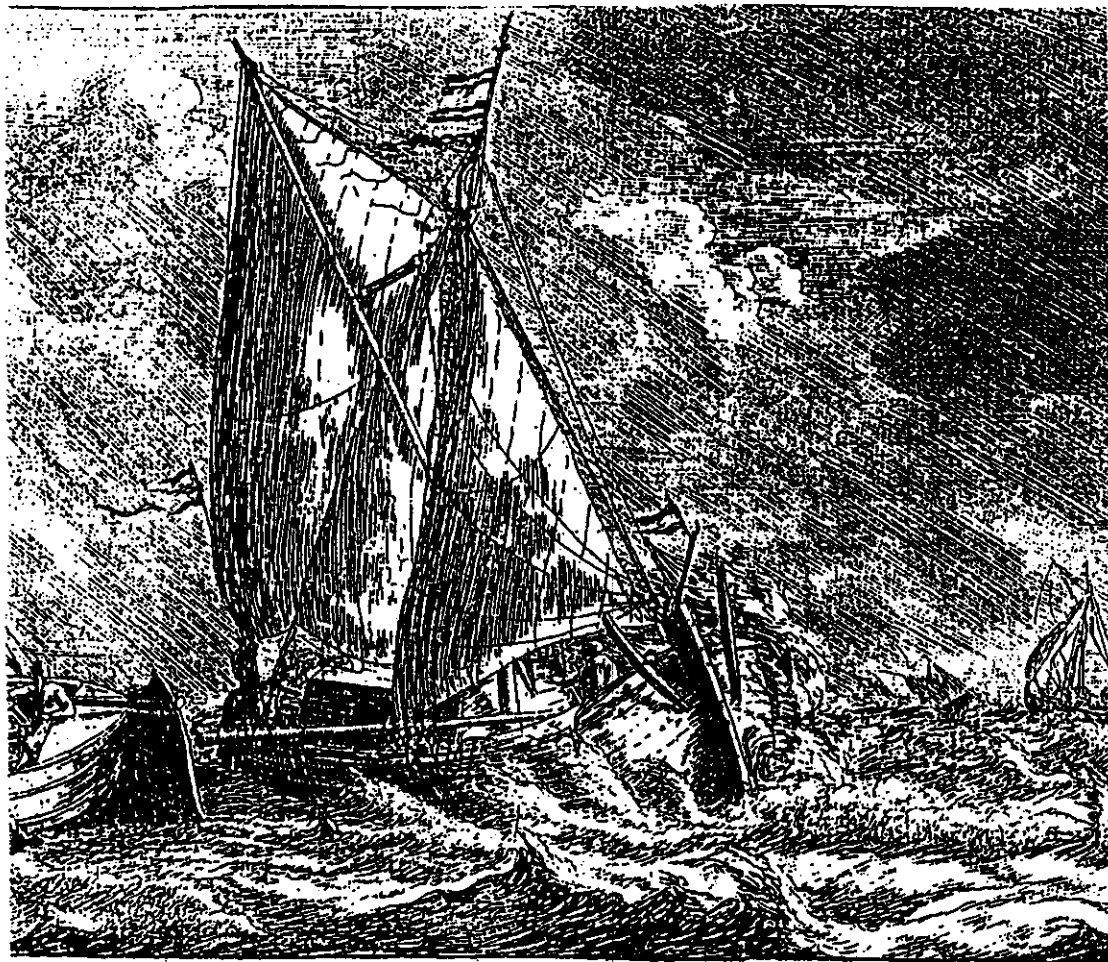

Figure 61. A drawing of a late waterschip (from Petrejus, 1971: 117).



Figure 62. Waterschepen towing a ship set in scheepskameelen.  
Lithograph by P. le Comte, 1831 (courtesy of Ned.  
Hist. Scheepvaartmuseum, Amsterdam).



Een Waterschip of Zuërzese Visser.

Figure 63. A depiction of a waterschip by Reinier Nooms, circa 1655 (courtesy of Nationaal Scheepvaartmuseum, Antwerp).

helmsman. Fig. 62 portrays a backstay fastened to the sheer on the aft starboard quarter, while Fig. 61 shows the backstays connected to the sheer by lanyards. It is likely that NZ421 had a similar arrangement.

W10 was reconstructed with four shrouds to either side. Florisz depicts seven shrouds to a side, and the anonymous etching from 1600 shows three (Fig. 46). A circa-1655 depiction of a waterschip by Reinier Nooms (Fig. 63) shows four shrouds to a side, while Fig. 62 depicts at least five. Thus it can only be suggested that NZ421 had between three and seven shrouds to a side.

As seen in the various depictions of waterschepen, they were gaff rigged, a sail type which had become widespread in the Netherlands by the early sixteenth century (Unger, 1980: 208). There is no doubt that this was also the type of rig on NZ421.

The dimensions of the mast foot, which were not recorded, can be reconstructed by the size of the mast socket, which was 31 cm. wide by 46 cm. long (p. 52). There was no evidence for the mast becoming round in section before deck level. Above deck level, the mast would probably be rounded since corners would be potentially injurious to the crew.

The mast's length can be estimated using a formula propounded by Witsen in the seventeenth century.

According to this, the length of the mast should be equal to twice the sum of the beam and depth in hold (Witsen, 1690: 129), or, as recalculated by Anderson,  $2.8 \times \text{Beam}$  (Anderson, 1982: 15). However, Anderson states that Witsen did not hold to his own rule, since a mast on one of Witsen's own ships was 80 feet long, when it should have been 84 feet (Anderson, 1982: 15-16). For the length of 80 feet, Witsen used  $2.666 \times \text{Beam}$  instead of  $2.8 \times \text{Beam}$ . Using Witsen's first figure for NZ421 yields a mast length over 14 meters, i.e.,  $2(5.02+1.98)$ , or  $2.8(5.02) = 14.056$  meters. Using the second figure of  $2.666 \times \text{Beam}$  yields a mast 13.38 meters long. Either of these mast lengths would not be out of place on NZ421.

Witsen also gave a rule for the mast thickness, based on the depth of hold: "De dikte van de mast wordt getrokken uit de holte van het schip: zoo menige 6 voet holte, 1 voet dikte" (Witsen, 1690: 129). By Witsen's rule, based on NZ421's maximum depth of hold of 1.98 m. and using 28.3 cm. for one Amsterdam foot (Verhoeff, 1983: 4), the mast thickness would be 33 cm. This figure is 2 cm. more than the size indicated by the socket. Thus, these later rules can only be used as a guide in reconstructions of earlier vessels.

As mentioned previously, there were three cuttings found on the inboard face of each kingplank (Fig. 31).

These indicate that there were missing mast partners both forward and aft of the mast. The partners were not fastened to the other timbers since there were no fastenings in, or near, the cuttings. The mortise between the first and second rider beams might have held a block, which would have fit tightly between the two rider beams. This was probably lost when the first rider beam became detached from the deck. This arrangement would have made the first rider beam part of the mast support structure by distributing stress between the two rider beams aft of the mast via the block (Fig. 31). Thus, the strength of the after mast support was doubled.

The notch forward of the second rider beam was for the vertical timbers forming the "sheath", as discussed on p. 70 (see also p. 195 below). The third cutting held a removable mast partner, which provided forward mast support. On the laths in front of this, would have been another removable timber, or perhaps an extension of the removable mast partner. Through this piece, the pump would have been inserted. This timber, lying on laths nailed along either side, may have had sufficient thickness to butt against the third rider beam. This would bring this rider beam directly into the mast support system, instead of indirectly through its fastenings to the kingplanks.

## The Cabin

Various depictions of waterschepen from the seventeenth century onward show these vessels with a cabin over their middles. As seen in the drawing by Florisz and in the etching from 1600 (Figs 45 and 46), the cabins cover the entire central area of the waterschepen. W10 was reconstructed with a similar cabin (Reinders, 1987: app. 1). These cabins had doors or entrances and a rounded roof low enough for the helmsman to see over. The conjectural cabin on W10 has a door in its side and cabins similar to this are seen in Figs 61 and 62. Also, the first waterschip ahead of the ship being towed in Fig. 62 has doors in both its side and after walls.

From the evidence on NZ42i, its cabin differed from these others. Whereas the cabins mentioned above covered the entire fishwell and the open area aft, the thin bulkhead aft of the trough on NZ42i was the forward extent of the cabin. This left the trough and more than half of the fishwell deck exposed. The rabbeted rider beam over the forwardmost stern deck beam delimits the after end of the cabin since its after wall would have sat in the rabbet. The small rabbet on the forward face of the rider beam was probably for the side wall of the cabin.

The after wall would have been only as thick as the

length of the nails protruding from the rabbet, i.e., 4 cm., and the forward wall, the same thickness as the thin bulkhead, i.e., 5 cm. The walls probably would have been lightly framed to save weight and, although there is no evidence for it, probably laid clinker fashion like clapboard, as seen in Fig. 61. It can be assumed that the seams were caulked with sinteling.

If NZ421 had a doorway in the forward cabin wall, it would have been to either side of the trough. Whether NZ421 had such a doorway can only be speculated upon since some depictions show a forward doorway while others do not (e.g., Figs 46 and 63). A door in the after wall would probably have been centered (Fig. 62), which might explain the stanchion supporting the deck beam since a beam bearing heavy traffic in one spot would have needed the additional support. Side openings might also have been part of the cabin construction, but there is no evidence for these.

### Conclusion

The reconstruction of NZ421 revealed that the vessel was a typical waterschip in major aspects such as shape, rigging and general construction. Peculiarities, such as the unusual cabin size, were also found on the vessel, possibly indicating that there were no set rules or

guidelines for the minor aspects. However, such idiosyncrasies as the truncated cabin may be due to NZ42i's earlier date.

## CHAPTER V

## ANALYSIS

## Introduction

As seen in the preceding chapter, waterschip NZ421, with its full bow, wine-glass shaped stern and centrally located fishwell, displays the major characteristics of the type as known from artistic representations and literary descriptions. As further seen, the form of NZ421 was well adapted to the environment and to the vessel's economic function.

In the following discussion, aspects such as stability, sailing capabilities, and the strengths of various timbers will be analyzed. In addition, the construction of waterschip NZ421 will be compared to waterschip finds and depictions, as well as to other vessels of northwestern European origin. An analysis of the ballast and a short discussion of the artifactual remains will be also presented.

Since many of the dimensions of hull components of NZ421 were reconstructed by the author, no attempt shall be made to correlate them to medieval or indigenous measuring systems.

### The Date of NZ42i

In chapter II, the vessel was tentatively dated to the fifteenth through seventeenth centuries. While no scientific dating techniques have been applied to the wreck, a more specific date has been determined based on the shape of the sintels (Fig. 9). The sintel form belongs exclusively to waterschepen built from the end of the fifteenth century to the middle of the sixteenth century (Vlierman and van Dijk, 1980: 4). Thus, on this basis, it can be concluded that NZ42i was constructed in this period.

### The Keelplank

As stated in the chapter IV, the keelplank was reconstructed without a rocker on the basis of a comparison of the hull with that of waterschip W10. A rocker would have been a desirable feature in the flat bottom since it would have made it easier for the vessel to free itself from the mud after low tide (McGrail, 1978: 116). However, as will be seen below, a different technology was utilized to serve this purpose, making a rocker unnecessary.

The keelplank has a long history in northwestern Europe and was only gradually superseded by the keel. Even so, it never completely vanished. Flat-bottomed vessels such

as the kahn and the hoogars continued to be built with keelplanks until modern times (van Beylan, 1978: 35, Ellmers, 1979: fig. 1.3).

The keelplank was a typical feature of Dutch vessels, although with it, sailing capabilities were reduced:

A keel protruding below the boat's bottom acts as an aerofoil in a fluid, thereby producing a sideways force opposing leeway. In general, the more a keel protrudes the greater this reaction. A keel-less boat with mast and sail but without anti-leeway devices such as great deadrise..., deep rudders, drop keels, (or) leeboards... will generally be restricted to sailing before the wind (McGrail, 1978: 111).

Thus, according to McGrail, a vessel like NZ42i would not have been effective at resisting leeway (McGrail, 1978: 115).

As the keel became increasingly popular on other ship types, it was not adapted for use on the medieval waterschip. Apparently, the lateral resistance that would be afforded by a keel was not a concern to the sailors or builders of waterschepen. Additionally, unlike other vessels in the Netherlands, the waterschip was never fitted with leeboards (van Beylan, 1970: 150) which became so common on other types that they became the trademark of Dutch vessels.

The improvement of a vessel's sailing capabilities by the addition of a keel or similar resistors would increase profitability by increasing vessel speed and maneuverability. Evidently, however, the waterschip's hull must have created sufficient lateral resistance to please the owner. This hypothesis is supported by Morwood (1962: 39-40):

Some shallow hulls will work to windward without any lateral resistance whatever....(A) boat 24 feet long by 8 feet and only drawing 12 inches of water was taken to windward by 100 square feet of sail in a strong wind, though a lot of leeway was made. The essence of these cases is in the limiting speeds of hulls. The beam of a boat is less than its length by a good deal so, even given equal efficiency in travelling sideways as forward, the speed sideways will sooner reach its maximum and act as very effective lateral resistance. The forward speed can then develop to its maximum

The vessel in the above example had a length to beam ratio of 3:1, making it beamier than NZ42i, whose ratio is 3.44:1. Thus, the narrower form of NZ42i, with its deeper draft, would have provided even greater resistance. This being the case, the waterschip was a better sailing vessel than would be implied by McGrail, although still not as efficient as it could have been with a keel or more deadrise. Perhaps, the additional

deadrise found on W10 was a response of builders to improve sailing characteristics (Reinders, 1986b: apps 8, 11).

## The Stem

### Form

NZ421's stem is similar to that of waterschip W10 in shape and in the number of components (Fig. 64), although due to NZ421's smaller size, its stem is smaller. However, the stem of W10 has a more sophisticated construction and larger relative dimensions, that is, the molded dimensions of W10's stem are greater in proportion to its height. Both of these aspects give W10's stem the appearance of greater strength. The change in the proportional size may be attributable to the switch to the carvel technique, since W10's hull would not be as strong as the clinker-built NZ421. This might make a more massive stem necessary in order to strengthen the bow. Also, the differences in stem construction may be due to the dissimilar building techniques. The stronger hull of the clinker-built vessel would make possible the less sophisticated stem construction. If the construction of W10's stem is indeed stronger, it may be a feature developed to compensate for the reduced strength of its hull. It is possible, however, the

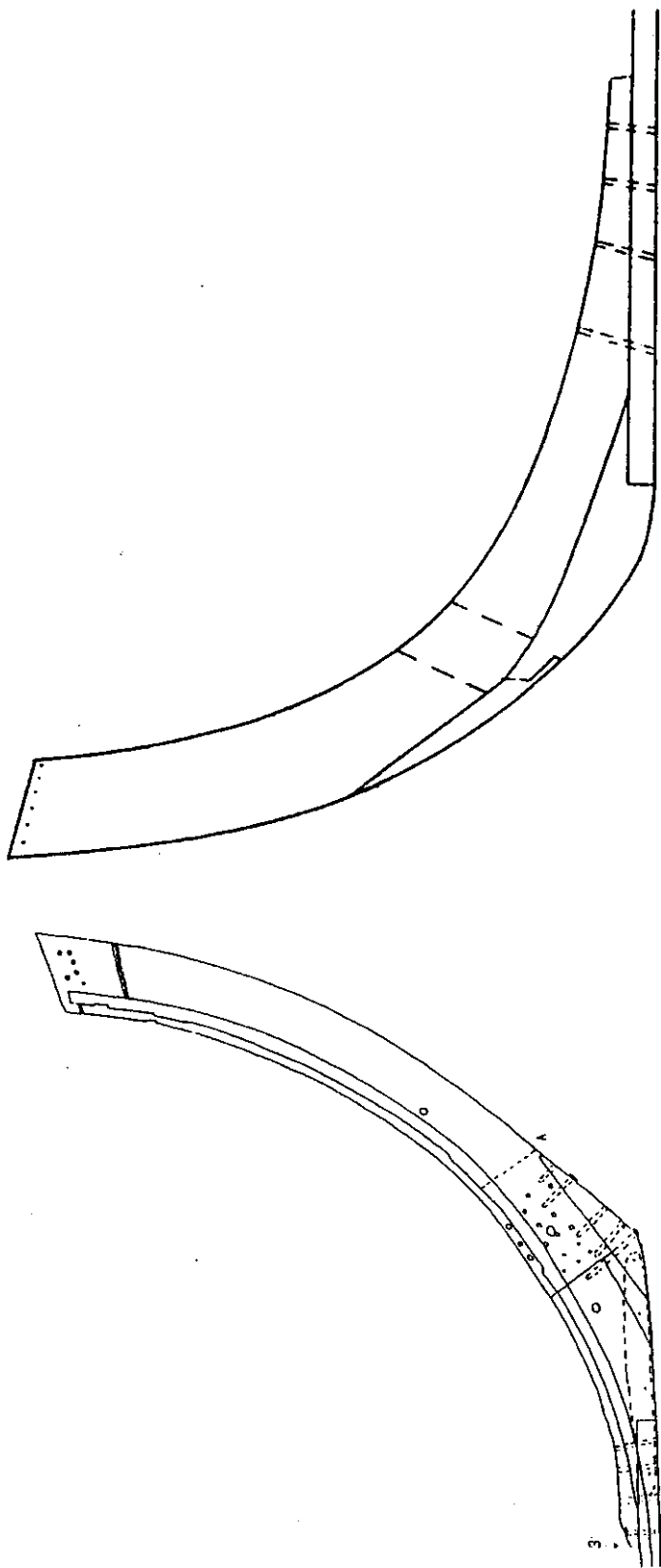

Figure 64. A comparison of the stems of NZ421 and W10 (scale= 1:50; W10 after Reinders, 1986b: app. 10).

differences are due only to the different construction dates.

### The Scarf

The horizontal scarf joining stem and keelplank is a common feature of vessels built on a keelplank and has been found on the tenth-century Graveney boat, cogs and other vessels (McGrail, 1978: 115-16). Since the keels of all these vessels were actually thick planks, "the horizontal type of scarf, which gave more room for fastenings in the horizontal than in the vertical face, was more appropriate than a vertical scarf" (McGrail, 1978: 116).

The scarf on W10, being longer than the one on NZ42i, would be the stronger of the two since it has a greater fastening area. Indeed, with only a single iron spike and three treenails, the scarf on NZ42i appears to be inadequate. The necessary strength, however, is imparted to the scarf through the clinker-built hull, particularly the garboards:

The strength of a scarf is by no means entirely dependent on the excellence of the fit and how firmly it is held together, important though these may be. It should be remembered that a scarf is reinforced by the continuity offered to it by the unbroken planks immediately above and below it. This mutual

interdependency for strength can be shown elsewhere in the clinker structure. The join between the stempost and the keel is greatly strengthened by the bracketing action of planking either side of it. A good builder will take this into account when shaping and placing these planks (McKee, 1972: 3).

The garboards of NZ42i are 57 cm. high on the stem and have no scarfs nearby. Thus, they provide "the bracketing action" necessary to keep the keelplank and stem together. In carvel construction, where support by the planking is not as great, the scarf would need to be longer, as on W10, to give the joint more strength.

### The Holes

The three holes bored through the stem (p. 16) are not unique to NZ42i. Similar holes were found on the Graveney boat, Nydam 2, a few of the Kalmar boats, the tenth-century Lake Paterswoide boat model, the logboat Kentmere 1 and the fifteenth-century Ebersdorf model (Fenwick, 1978: 213, fig. 8.12a; Åkerlund, 1963: pl. 1; Åkerlund, 1951: pl. 16, 25, 27; McGrail, 1978: 125; Steusloff, 1983: 194). While the holes on some of these vessels are on the sternpost, e.g., the Graveney boat, their placement is similar to those on NZ42i. On both Nydam 2 and the Graveney boat, the holes, two in either post of Nydam 2 and two in Graveney's sternpost, are

placed low like the ones on NZ42i. The Ebersdorf model, however, has two holes in the upper stem (Steusloff, 1983: 194).

The function of the holes on any of these vessels is not certain. According to Åkerlund, the holes on Nydam 2 were for the attachment of a quarter rudder (Åkerlund, 1963: 156). Fenwick states that the probable purpose of this arrangement was to increase waterline length when needed, and that this in turn eventually led to the invention of the stern rudder. (Fenwick, 1978: 213).

However, the holes on the Graveney boat's sternpost were "ideally placed for hauling her out of the water" (Fenwick, 1978: 213). McGrail holds a similar view in which the holes "seem best interpreted as attachment points for securing lines when beached or moored" (McGrail, 1978: 125), although he also raises the "possibility that such holes were used during the building of the boat." (McGrail, 1978: 126).

Any of these last three possibilities may be valid for NZ42i. The idea that the holes were for the attachment of a rudder is invalid for NZ42i for obvious reasons.

Since some waterschepen were used as tugs, one may be tempted to interpret the holes as attachments for towing lines. Their placement on the stem does not preclude this since the waterschepen in Fig. 62 appear to be

attached stem to stern. While the holes may be used in this manner on vessels with the holes high on the stem, as they are on the Ebersdorf model and appear to be in Fig. 62, this is an unlikely possibility for NZ421, since the holes and lines would have been underwater. Thus, the best explanation is that they were for hauling the vessel onto the beach or skids for repair or wintering.

### The "Stabilizers"

One of the more interesting features concerning the stem is the pair of timbers dubbed "stabilizers" by the excavators. In profile, these timbers have some resemblance to a section of an airplane wing. Indeed, if they were stabilizers, they would be the medieval equivalent of the forward canards of modern small aircraft. As stabilizers, these timbers, by way of the flow of water above and below them, would have prevented the vessel from pitching as greatly as it otherwise would have. However, this hydrofoil action is unproven, as well as unlikely due to the small size of the timbers. The timbers would have provided some additional buoyancy to the bow, which might have prevented the vessel from pitching as greatly as without the timbers.

I believe the timbers were intended to perform other functions. One of these functions was to act as runners.

In this capacity, the timbers kept the stem's heel from becoming stuck in the mud of the shoals or shore. The stem is bearded off, creating a leading edge of 7 cm. at the heel (p. 15). Thus, the knife-like stem would cut deeply into the mud, possibly creating a problem in refloating the vessel, as was alluded to in the analysis of the keelplank (p. 150). By increasing the surface areas of the forward edge and bottom of the stem, the timbers would preclude the digging in of the heel by lifting the vessel over the greater mass of the mud as it made contact.

An experiment was conducted to discover if the timbers performed in this manner. A model of the stem and keelplank was crafted from illustration board. The model was mounted on wheels in order to imitate the forward motion of the vessel in water. A "mud" bank was also created to simulate a shoal or beach head.

The experiment was in two parts. The first part involved pushing the model into the bank without the timbers in question attached. The second part involved the same procedure but with the timbers fastened to the model. Fig. 65 shows the result without the timbers. As can be seen, the stem cut deeply into the bank, although due to the angles of the stem face and the bank, it was lifted upward slightly. Fig. 66 shows the result with

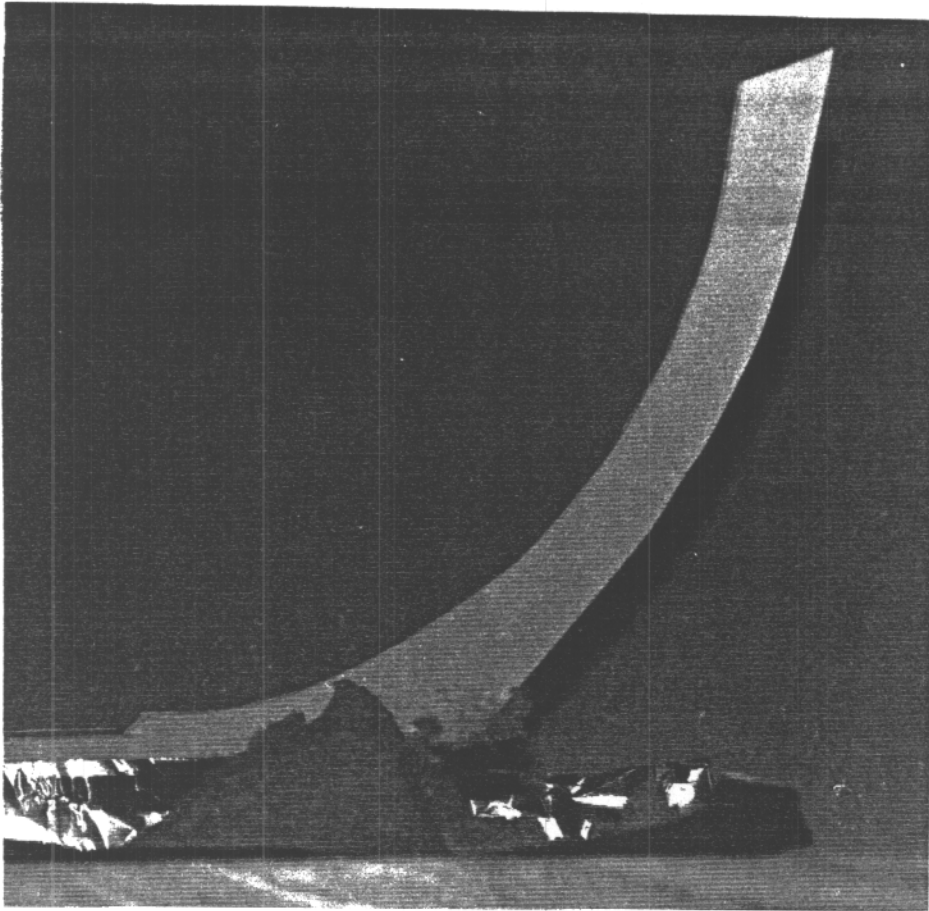

Figure 65. Beaching the stem without the runners.

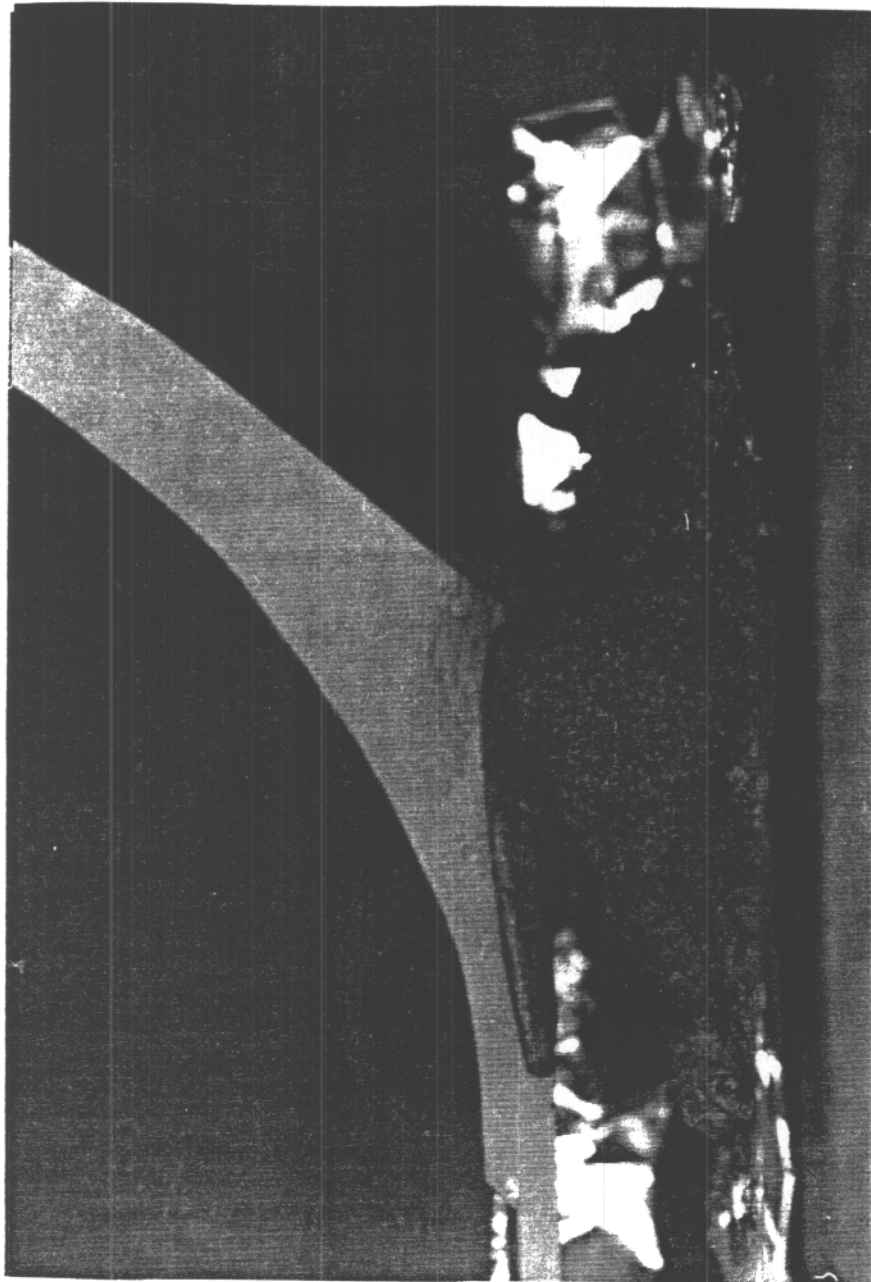

Figure 66. Beaching the stem with the runners.

the timbers. As can be seen, the timbers performed in the manner theorized above. With the timbers in place, the stem did not penetrate into the bank as deeply as was otherwise the case.

Another function of these timbers was demonstrated in the experiment. As can be seen in Fig. 65, the stem penetrated deeply enough to bring the "mud" into contact with the area of the garboard's hood ends. On the actual vessel, such repeated contact would cause undue wear on this important area, ultimately causing the failure of the hood ends and the loss of the vessel. As seen in Figs 66 and 67, the runners not only raised the vessel high enough to prevent contact with the garboards, but also laterally deflected the "mud" away from the hull.

Thus, this simple pair of timbers not only gave the bow some additional buoyancy, but also performed as runners to keep the vessel free from the mud, and as deflectors to protect the bottom planking from the forces of initial impact with the ground.

## The Planking

### Fairness

To plank a clinker-built boat so that all the plank seams are perfectly fair, sweet and well fitting is something of an art....

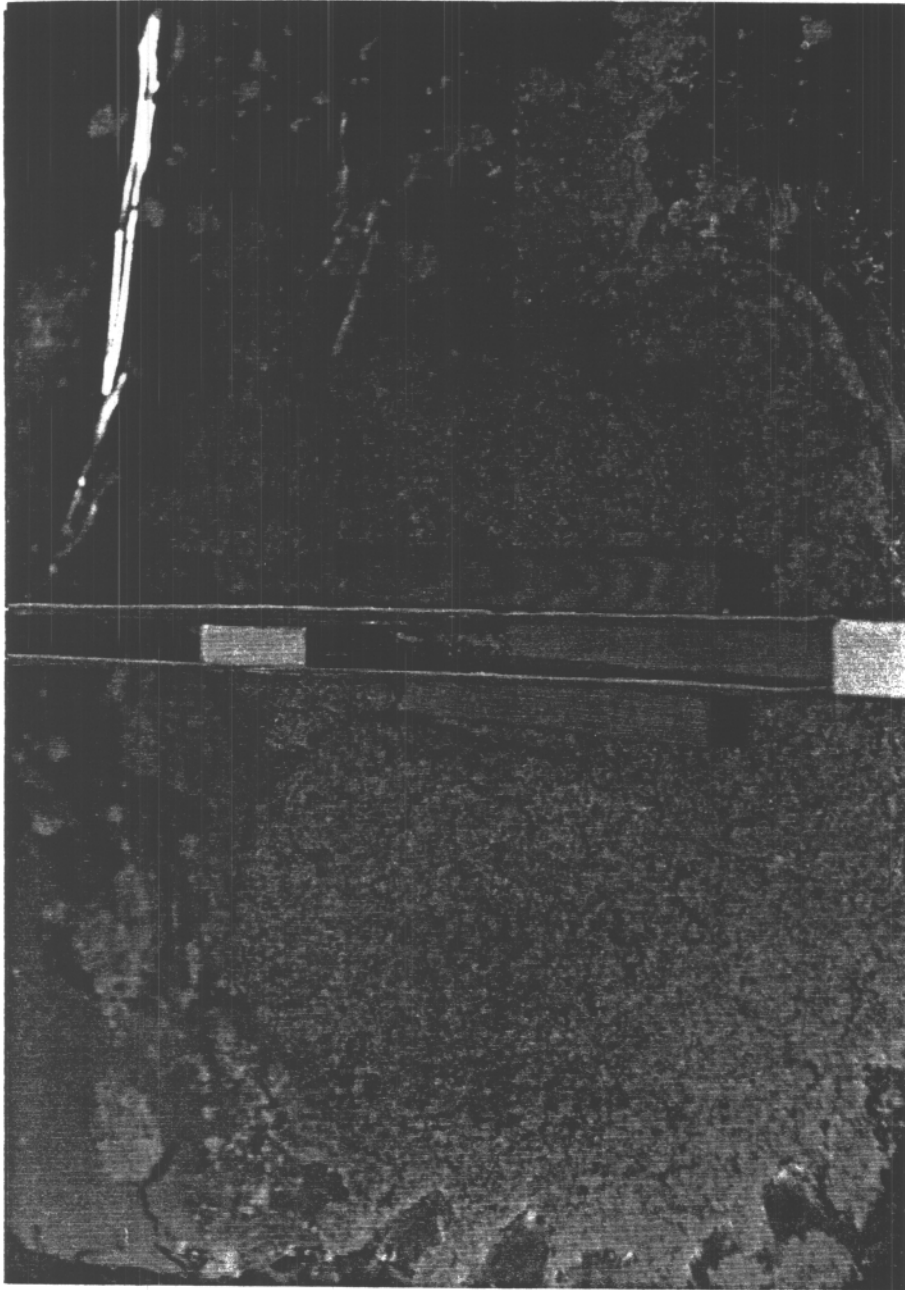

Figure 67. The deflecting action of the runners.

Nothing spoils the appearance of a clinker boat more than irregular plank widths or distorted sheer of the lands (Leather, 1973: 75, 76).

On NZ421, function took precedence over beauty. As seen in the reconstructed planking plan (Fig. 43), the planking is fair and sweet, for the most part. The most obvious exception is found in the stern view of the second port strake whose landing with the garboard snakes greatly in comparison to the others. This is also manifested in the third and fourth strakes, although to a lessening degree. The landing is a reconstruction based on the upper edge of the garboard. It is possible that when the builders fashioned these planks, they made the outside edge of the landing sweeter than it appears in the reconstruction. However, in order to keep within the parameters of minimal reconstruction, the landing was not drawn more fair. Thus, it is possible that the builders should not be blamed for the irregular appearance of the landings.

It is apparent from the inside of the hull that the strakes themselves were not made as fair as they could have been. Some of this was necessary. For example, the upward bend of the strakes at body station 11 was needed to produce the high bow while avoiding an extra wide sheer strake. Also, the bulging of the third port strake

in the fishwell was necessary to increase the width of the bottom and the volume of the fishwell. This made each trip out to sea more profitable by increasing the size of the catch able to be brought home for the same amount of transit time invested.

Undoubtedly, the builders could have produced an aesthetically pleasing vessel. The handling and crafting of long, thick oak planks to fit on a three dimensional object required expertise "backed by generations of tradition and experience" (Leather, 1973: xiv). Men able to craft a vessel of this size must have been highly experienced and capable of the extra work needed to produce a finer vessel. However, since NZ42i was only a working vessel, this was unnecessary.

### Strake Construction

"The intelligent use of scarfs is a sure sign of a sound boatbuilder," (McKee, 1972: 2). NZ42i has an average of 3.25 planks/strake with a mean of 4 planks/strake. The upper strakes have more planks, and therefore more scarfs, than the lower ones, e.g., 4 in the eighth port strake as opposed to 2 in the port garboard. It may be claimed that this is due to the longer length of the upper strakes. Actually, it is because shorter planks can be more easily used where much curving of the strake

is necessary since longer planks would have to be worked into complex shapes requiring a greater amount of labor (McGrail, 1978: 126).

Consequently, scarf placement was determined by where the transition into the ends could be accomplished best without fashioning greatly curving planks. The shorter planks were used toward the ends, while long, straight planks were used in the area between the mast and the after end of the fishwell.

While this method facilitated the planking process, the result was the clustering of scarfs forward and after the fishwell. Since a scarf is weaker than the planking, it is best to avoid such groupings in order to prevent large, relatively weak areas in the hull. McGrail states that, although rules for scarf placement are difficult to identify, "(i)n recent shell boat building it has been the practice to distribute plank scarfs so that they are not close, vertically or laterally; thus a boatwright's rule of thumb might be to have a minimum of two strakes between two scarfs that are that are within four frame stations of each other" (McGrail, 1978: 127). There is some evidence that early shipbuilders recognized the need to avoid clusters of scarfs. An example of this is the Graveney boat where, although scarf placement did not follow a rule, there seemed to be an attempt by the

builder to distribute the planking scarfs among the stations (McKee, 1978b: 97).

No such effort was made on NZ42i, and the lack of an attempt at scarf distribution undermined the strength of the hull. Furthermore, since a clinker-built hull has both its sides laid out in similar fashion, as will be discussed below, the clustering was replicated on both sides. This resulted in weak sections in similar areas to port and starboard.

The planking scarfs of NZ42i were 45 cm. long on average and, using an average plank thickness of 3 cm., had a gradient of 1:15. This is greater than scarf gradients found outside the Netherlands, e.g., the Graveney boat which had a gradient range of 1:2.7 to 3.1, or the scarfs found in the reused wood from the twelfth century waterfront of Wood Quay which had gradients of 1:6 to 8 (McGrail, 1978: 127). As for Dutch vessels, the barge K73/74 had a gradient of 1:9.7 (Reinders, 1986a: fig. 5); NZ43 had a average gradient of 1:8.6; and the unreconstructed waterschip NZ44, with a scarf length of 40 cm. and a plank thickness of 3 cm., had a gradient of 1:13.3. Unfortunately, data for other waterschepen are wanting. It is not possible at present to determine whether the high gradient value of NZ42i is typical of

clinker-built waterschepen, although the similarly high value of NZ44 supports such a supposition.

### The Landings

Thinner planking is required for clinker planking than for carvel because the double thickness of the plank lands, or laps,... compensates, while carvel planking must generally be thicker to hold caulking to make it watertight... (Leather, 1973: 75).

Since a clinker-built ship or boat has its strength in its planking rather than its frames, it would be a reasonable assumption that thick planking would be desired in order to impart more strength. However, as Leather mentions, the planking can be made thinner since a large amount of strength lies in the landings. Thus, the landings can be viewed as a series of integral, longitudinal reinforcing timbers such as ribbands or narrow wales. These must be made accurately and with enough overlap to impart the required strength.

A modern rule of thumb for the crafting of landings is: "Overlaps should be twice the thickness of the plank..." (McKee, 1972: 4). This does not apply to NZ421 where overlaps were 6 to 10 cm. wide and plank thicknesses were 2.5 to 4 cm., yielding ratios of 1:2.4 to 4. These high values indicate that the builders were concerned with making the landings sufficiently strong, although the

wide range demonstrates that they followed no rule. This is in agreement with McGrails' determination that medieval finds display no set rule for the size of overlap in regard to McKee's rule of thumb (McGrail, 1978: 128). The landings most likely were determined by eye only.

### Planking Symmetry

The notion that the landings were set by eye is supported by Leather, who states that traditionally, planking "was done largely by eye... working the planks in pairs so that both sides were planked with equal pressure..." (Leather, 1973: xv). As can be seen in Fig. 44 and table 1, the port and starboard sides of NZ421 were laid out in similar fashion.

Conceptually, each side of the vessel was a mirror image of the other. Not only were the port and starboard planking widths at each body station similar (Figs 40a, b), but the numbers of planks per strake, plank lengths and scarf placements on each side were also in concurrence. Indeed, there was only one exception to this pattern among the surviving strakes. This was the fifth pair of strakes, which was the only set whose number of planks to port was in disagreement with the number to starboard. To port, the fifth strake consisted

of two planks while to starboard there were three. The forwardmost plank to port was the longest on the vessel, with a reconstructed length of 11.4 meters. The corresponding portion of the fifth strake to starboard consisted of two shorter planks, while the after planks of each side were nearly the same. These differences reveal that the builders were not trying to create perfect sets of strakes, but only similar ones in order to produce a symmetrical hull. This, of course, would make the vessel easier to sail than if there were a large amount of asymmetry.

It is possible that each pair of planks was cut from the same piece of timber or log. This, however, is not supported by the repair work. If each pair was cut from the same length of lumber so they shared the same grain pattern on their inner faces, then there would be a greater coincidence of patches on either side of the hull. This is not the case since only the third strakes have matching repair patches. However, it may be that the planks were cut so the outside face of one had the same grain pattern as the inside face of the other. In this case, faults in the wood would not correspond since they probably would not extend through the piece. Consequently, an examination of the actual planking is

required to determine if sets of planks share the same grain pattern.

### The Repairs

The repair patches are numerous and are a feature of the original construction, as was stated in chapter III. The damaged areas of the wood covered by the patches were described by the excavators as scheuren (sing. scheur) which is translated as tears, ruptures or splits (Wolters, 1987). Thus, the scheuren could be surface checks, end checks, shakes, or actual splits.

A surface check is "a tensile failure perpendicular to the grain, caused by drying and shrinking of the surface zones while the interior is still at a relatively high moisture content and unshrunk." They usually originate "where there is a natural break in the continuity of the wood fibers, such as a knot, ...or a ray in hardwoods. Wide stock surface checks more readily than thin stock" (Dept. of the Navy, 1958: 98).

End checks are separations of the wood fibers across the growth rings which "soon turn into a lengthwise separation of the wood as they progress inward." These result from "rapid drying from the end grain and the exposure of the ends of the wood fibers." End checks

"are responsible for much waste of material because, for many purposes, checked ends must be trimmed off" (Dept. of the Navy, 1958: 98).

A split "results when an end check and a surface check meet." This "is usually more serious than an end check or a surface check, because it is likely to extend farther along the face and deeper into the piece. In boards, splits often extend from face to face" (Dept. of the Navy, 1958: 98).

A shake "is a longitudinal crack along or between the annual rings [which] originate in green timber. They may, however, become accentuated in seasoning" (Dept. of the Navy, 1957: 32).

Which of these faults the patches cover is unknown. It is unlikely that they cover a split that extends from face to face, since it is doubtful that the builders would use such a piece for planking, if it indeed could be used.

Some of the faults appear to be more serious than others. As can be seen in the planking diagram (Fig. 44), two of the repairs, one on the eighth port strake and the other on the sixth starboard strake, extend for almost the entire length of the plank. Also, there are two repairs on the forward part of the port garboard. It is surprising that such damaged pieces would be used for

planking, since checks, shakes and splits undermine the strength of the clinker-built hull. Also, the use of a less than perfect plank on an important area like the garboard is foolhardy since it must take the abuse of beaching and accidental grounding, the runners notwithstanding.

The defects, whether natural or due to improper seasoning, can provide access to mariner borers, cause leaks and are conducive to decay through the retention of water (Dept. of the Navy, 1962: 186). They also "may seriously weaken wood members in resistance to longitudinal shear" (Dept. of the Navy, 1957: 32). The U.S. Navy has calculated this loss of strength as ratios based on the depth of the shake or check and the nominal end thickness of the wood. For example, a piece of seasoned timber 2 inches (5 cm.) thick with a shake or check 1 inch (2.5 cm.) deep will have a strength equal to 52% of the strength of an undamaged piece (Dept. of Navy, 1962: 169, 184). Thus, if a 3 cm. plank from NZ42i had a check 1.5 cm. deep, nearly half of its strength would be gone. Factoring the reduced strength with the number of repairs in the hull of NZ42i, it would appear that the builders were either unwise or ignorant of the dangers of using damaged wood, and thereby seriously undermined the hull's integrity.

Indeed, the hazards were eventually manifested because one of the faults was responsible for the vessel's loss. As is seen in Fig. 68, there is a hole through the hull under the patch on the forward plank of the second starboard strake. Evidently, for whatever reason, whether being struck by a freely swinging anchor as suggested by the excavators, or by just giving way due to decay and stress, the vessel sank when this flaw and its repair patch failed. This area of the plank was not readily accessible due to the overlying bottom stringer and could neither be maintained properly or plugged easily when the leak occurred. Thus, the defects in the wood eventually proved fatal to the vessel, if not the crew.

Ultimately, the question is raised as to why such a poor grade of wood was used. It may be that the builder was simply reducing overhead. Cutting off pieces with checks, shakes or splits, produces much waste, necessitating the purchase of more wood. It has been estimated that the cost of wood accounted for 45% of a vessel's cost in the fourteenth century (van de Moortel, 1987: 234) and approximately 60% in the seventeenth century (Hart, 1977: 72). If the builders of NZ42i had cut off all the damaged pieces, they would have needed to purchase an additional 13.5 meters of wood, roughly 5 to

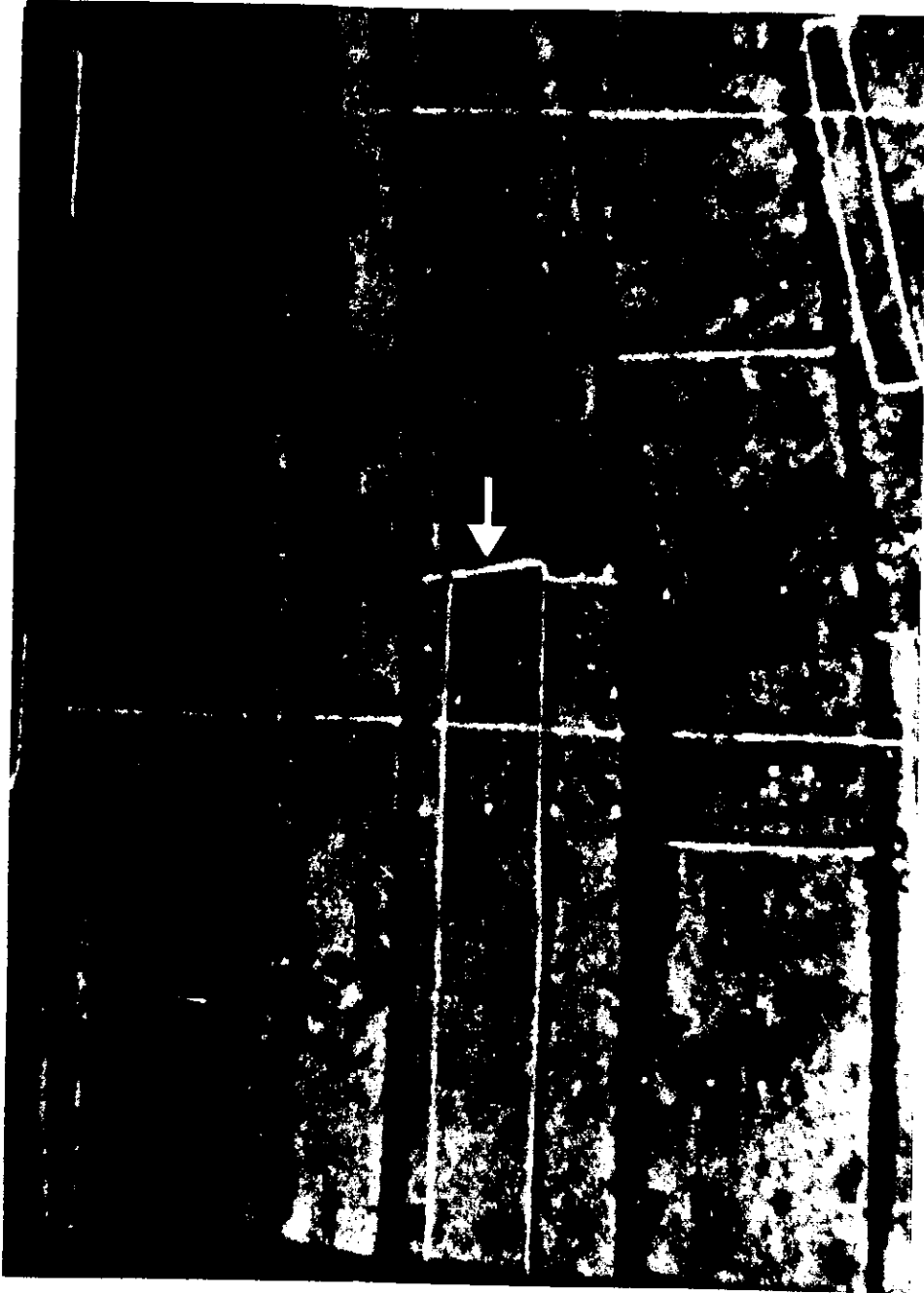

Figure 68. The hole through the hull (courtesy of RIJP).

6% of the planking, to account for the waste. Cost would have risen accordingly.

The high cost of wood was due to a lack of indigenous supply. By the late Middle Ages, the supply of wood in the Netherlands was dwindling and by the seventeenth century, trade in timber with Germany and Scandinavia was a major facet of maritime commerce. "Timber was the most essential raw material in the 17th century. Before iron ore could be properly handled, timber was used in almost all human activities. Timber was in particularly high demand in (the Netherlands), a country without forests of any importance (Bruijn, 1985: 127)." While NZ42i predates this period, the supply of local wood in the previous century must have been limited. Additionally, before the timber trade was fully developed, imported wood would also have been limited. Whether wood was imported or harvested from a shrinking native crop, tight supply would have increased the cost. If the builders of NZ42i had opted to purchase more wood, the grade needed might not even be available, causing a delay in construction and creating a further cost increase. Such increases would have been restrictive not only for the builders but also for the vessel's buyer. In view of these factors, one can understand why the builders used the damaged materials.

As noted in chapter III, resin was used instead of sinteling in making one of the repairs, most probably at some later date. How much later is not known. While it is possible that the vessel leaked from the time of construction, the builder probably would have re-sinteled the affected areas. Thus, the repair was probably made by the owner/fisherman in the course of routine maintenance.

The presence of the repair reveals that the vessel was undergoing periods of stress in the bow which loosened the seams and caused the leaking. These stresses could have been due to rough seas or to intermittent beaching. Either way, the repair indicates that NZ42i was in service for a while before it was lost. This notion is reinforced by the presence of a wear mark, either from towing or hauling nets, found on a piece of planking (see page 78).

#### The Hooding Ends

Since most of the hooding ends did not survive, and the lower ones that did were not recorded, it is uncertain how the ends were constructed. There are two methods for closing the ends on a clinker-built vessel. The first is to run the strakes into the posts without any change in the overlap. The second method is to gradually change

the overlapping planks into flush-laid ones by means of long scarfs along the planks' edges.

Such flush-laid hooding ends would have no need of joggles on the posts. Hence, the joggles in the stem's rabbet indicate that the ends were constructed by simply running the strakes into it, especially since there is enough room in the rabbet to permit the double thickness of the landings. Likewise, the joggles on the post also indicate this method. However, if the recorded depth of 4 cm. for the rabbet on the post is correct, then it would be insufficient to receive the double thickness of the landings. Thus, the planking in the stern would have to be at least partially flush-laid in order to reduce the thickness at the landings. One cannot say whether or not the two different methods were employed in one vessel, but it seems more likely that the recorded depth of the post's rabbet is in error.

### The Framing

Being clinker-built throughout, NZ42i was built shell first. It is possible that some framing, such as the lower bulkhead pieces or the floor timbers, were added before the shell was completed, but there is no evidence for this.

The frames were not fastened to the keelplank or posts. This feature is also found on Viking vessels (McGrail, 1987: 145), and the Graveney boat (Fenwick, 1978: 240), but not on cogs (van de Moortel, 1987: 129). This is perhaps an indication that NZ42i had a closer affinity to the former vessels. The frames of waterschip W10 were also not fastened to its keelplank (Reinders, 1986b: 14, 15).

Gaps were left at the frame joggles. This permitted water to flow freely under the floor timbers to the pump or drain. This is particularly important since there were no limber holes in the floor timbers and leads one to believe that the gaps were made intentionally for this purpose. However, since the joggles on the futtocks were also roughly cut, it may only indicate a lack of precision and care.

The broad, close framing found on NZ42i is typical of late medieval craft. "By the fourteenth century, clinker-built ships already had an extensive system of heavy oak internal supports along with bulkheads to separate cargo holds. Over time, builders had put the ribs closer and closer together, almost creating another wall inside the wall of hull planking" (Unger, 1980: 225).

Due to the lack of information about other waterschip wrecks, it is not possible to determine whether the spacing between the frames of NZ42i is characteristic of waterschepen. However, the 40 to 45 cm. spacing on NZ42i is similar to that found on the clinker-built NZ44, where the frames were spaced an average of 42 cm., center to center. This may indicate that this spacing is typical of waterschepen, although the carvel waterschip W10 had frames placed every 25 to 55 cm., with a mean of 35 cm. (Reinders, 1986b: app. 5).

The figures for the two clinker-built waterschepen are greater than those stipulated for shipbuilding in general by van Yk in 1697, who wrote that frames should be 14 to 15 Amsterdam inches apart (van Yk, 1697: 78), or converted to metric, 33 to 35.5 cm. where 1 Amsterdam inch = 2.36 cm. (Verhoeff, 1983: 4). Although van Yk wrote over a century after W10 was built, his figures are close to the mean of the carvel-built W10.

In contrast, the frame spacing on NZ42i is less than found on earlier vessels such as the Gokstad ship, where frames were set 97-100 cm. apart (Dammann, 1983: 10) and the Graveney boat where they were 50 cm. apart (Fenwick, 1978: 236). Apparently, the available evidence supports Unger's statement, and perhaps frame spacing can be used as a tool for approximating the construction date of

vessels. On the basis of this criterion alone, NZ42i would predate W10. However, the change to carvel construction is a complicating factor because it is unknown whether the frame spacing of W10 reflects the change to carvel or only a general gradual lessening of space between frames over time.

The style of the fishwell framing is characteristic of waterschepen. On both NZ42i and W10 the frames are similar in size, shape and number. Their rounded cross sections are attributed to erosion from the fish being constantly washed over them as the vessel sailed (Reinders, 1986b: 15). However, one wonders if the frames might have been purposely made this way to prevent damage to the fish, which cornered timbers would have caused. An examination of the frames might provide evidence for this through the detection of tool marks.

The stern frame configuration on W10 is also similar to NZ42i's, although the scarfing method is different. Similarities in the frames of both vessels include floor timbers which reached to the turn of the bilge on one or both sides (Reinders, 1986b: 15) and the deep carving of the floor timbers over the centerline (Reinders, 1986b: fig. 6). While NZ42i has futtocks resting on top of floor timbers, W10 has the two pieces scarfed on their sides (Reinders, 1986b: fig. 6). The framing scarfs on

NZ42i were short, and a longer overlap, such as that on W10, would have given the joint more strength. However, since the framing strength was secondary to the clinker-built planking, the strength of the joints was a small consideration.

Construction of the forward frames of both waterschepen was also similar, again with the exception of the scarfs.

Thus, although only two waterschip wrecks have been properly examined, a picture of the type's framing style seems to have emerged. However, how closely the framing on other waterschip wrecks resembles the framing of either NZ42i or W10 remains to be seen.

### The Fishwell

Aside from the distinctive shape of the hull, the most recognizable feature of the waterschepen was their fishwell, known in Dutch as a bun. Fishwells were not, however, unique to the waterschip. Vessels such as the tochtschip, a.k.a. drijver (van Beylan, 1970: 149), and the hoogaars (van Beylan, 1978: 34-35) were also built with this feature. Additionally, the fishwell predates medieval Dutch vessels, as is seen in the vessel equipped with a small fishwell found in the Roman port of Ostia (Testaguzza, 1970: 144). While this Roman find may point to the origin of this feature, this possibility cannot be

elaborated upon without further evidence linking the two areas and eras.

A ship or boat with a large pool open to the sea in its middle presents special problems. First of all, the vessel must have sufficient buoyancy to compensate for having its midships section effectively sunk. Secondly, the separations between the wet area and the dry areas must be properly sealed to prevent leakage. Thirdly, the separations must be of adequate strength to stand up to water pressure and the shifting of the fish and water. Lastly, the planking must be made strong enough so the many holes needed to keep the water circulating do not undermine its strength and cause the loss of the vessel.

### Buoyancy

Obviously, a vessel with a fishwell must have dry areas of sufficient buoyancy to compensate for the well. The full bow and wide bottom on NZ42i displaced a great deal of water thereby giving the vessel its buoyancy. This undoubtedly more than compensated for the fishwell.

Indeed, that waterschepen constantly carried up to 20 tons of ballast and cargo attests to their great buoyancy as well as their stability (Reinders, 1986b: 29).

As will be seen in the following chapter, some waterschepen were used as lighters and did not have a

fishwell. This gave them additional buoyancy which enabled these lighters to carry approximately 10 tons of dry cargo in addition to their usual ballast.

#### The Caulking of the Bulkheads

Unfortunately, the method for caulking the bulkheads on NZ421 is not known. This is also not known for W10. However, this data is available for NZ44. On this waterschip, the seams between bulkhead sections were rabbeted and sintered, as was the juncture of the planking and bulkheads. It is likely that this was also the method used on NZ421.

#### The Strength of the Bulkheads

The strengths of the forward and after bulkheads must have been a consideration to the builder, since, if they were inadequate, the vessel would be lost. As noted in chapter III, these bulkheads were massive, strongly reinforced and firmly fastened to the hull. The need for strength is demonstrated by the combination of treenails and iron nails fastening the bulkheads to the planking, as well as by the long iron spike through the bulkheads' centers. The sturdiness of this construction is evident because the forward and after bulkheads survived the

centuries intact, while the less-reinforced middle bulkhead collapsed.

The forces acting on the bulkheads must have been considerable to warrant the thickness, the fastenings and the reinforcement by the iron spikes. Not only was there the water pressure with ~~water~~ *which* to contend, but also the force of the water and fish hitting the bulkheads as the vessel pitched with the waves. The shifting nature of the cargo also required reinforcement of the fishwell deck, since side-to-side roll might send the cargo into the waterway, and in a rough sea, into the decking. Reinforcement was provided by the many thin treenails fastening the waterway to the sixth strake and by the overlying rider beams, which held the fishwell deck down and the cargo in.

The forces applied to the fishwell structure depended on the amount of the cargo affected. The fishwell of NZ421 was 3.4 m. long, .96 m. high and 4.52 m. wide amidships. Using estimated areas of the forward and after bulkheads, the fishwell of NZ421 had a volume of nearly 11 cubic meters, or a maximum capacity of 11 tons of water. However, since it is not likely that the well was filled to the bottom of the trough, its actual capacity may have been around 8 to 9 tons. In comparison, the fishwell on waterschip W10 had a volume

of 13 to 14 cubic meters, with a carrying capacity of 10 tons of water and fish (Reinders, 1986b: 29).

As NZ421 would pitch with the sea, the mix of 8 to 9 tons of fish and seawater would shift and be forced against the forward and after bulkheads. While the amount of shifting would be greatest near the surface, in a rough sea or storm most of the fish would probably be affected. Upon the impact of the mass with the forward bulkhead, the force would propel the vessel down into the trough between the waves, driving it deeper into the water and inhibiting its ability to climb the ensuing wave, an action which could have serious consequences. Likewise, the backward motion of the cargo caused by the bow pitching up would create a drag on the vessel, creating problems for the helm. If, however, either bulkhead were not strong enough to withstand the force of impact, it would yield, probably causing the vessel to sink.

It is here that the middle bulkhead served its purpose. An argument can be made that the fishwell could have been built without this bulkhead, since it imparts little to the structure. Slightly heavier framing and deck beams could have given sufficient support to the fishwell deck and hull without sacrificing volume because the absence of the middle bulkhead would have compensated for this.

Additionally, with its absence, the opening at the bottom of the trough would have been twice as large, making the retrieval of fish from the well easier. However, the middle bulkhead was a necessary component of the vessel since it acted as a baffle to stabilize the fish and water by dividing the cargo in two. This made the presence of a pool of water amidships safer since it had only a fraction of the mass shifting only half the distance. Therefore, by hampering the cargo's movement, the middle bulkhead reduced the forces acting on the bulkheads, making the vessel safer and more stable.

Since a force equal to that on the forward bulkhead would be applied to the middle bulkhead by the cargo in the after section of the fishwell, or by the cargo of the forward section when the vessel pitched back, the middle bulkhead was strong enough to withstand the force without the additional reinforcement found on the other bulkheads. Therefore, the additional thickness and reinforcement of the forward and after bulkheads were needed only to resist the water pressure.

#### The Strength of the Planks

As a clinker-built vessel, much of the structural integrity of NZ421 rested in its strakes. Accordingly, the planking would need to be strong enough to avoid

being undermined by the pierced planking in the fishwell. This raises the question of whether planking thickness was increased to account for the piercing. One way to answer this would be to find a waterschip without the pierced planking. However, such a find does not exist at present.

Obviously, since it was intact, the fishwell planking was strong enough, even though the numerous holes cut much of the wood grain. In order to find the amount of the loss of strength, an experiment was conducted using oak planks in 1/5 scale, modeled after the fifth port strake between the middle and forward bulkheads (Fig. 69). One of these model planks was drilled through with holes arranged in a diamond pattern, while the other was left intact. The wood used was a commercially available oak commonly used for flooring in the United States. While it may have been more accurate to use a northern European oak, such materials were unavailable, and the American oak was judged adequate for the purpose.

Each plank was set in an arrangement in which weight was applied to its center beginning with five pounds (2.27 kg.). This was subsequently increased in five pound increments to a total of fifty pounds (22.7 kg.). The deflection, or bending, of each plank at each increment was recorded and plotted in a graph (Fig. 70).

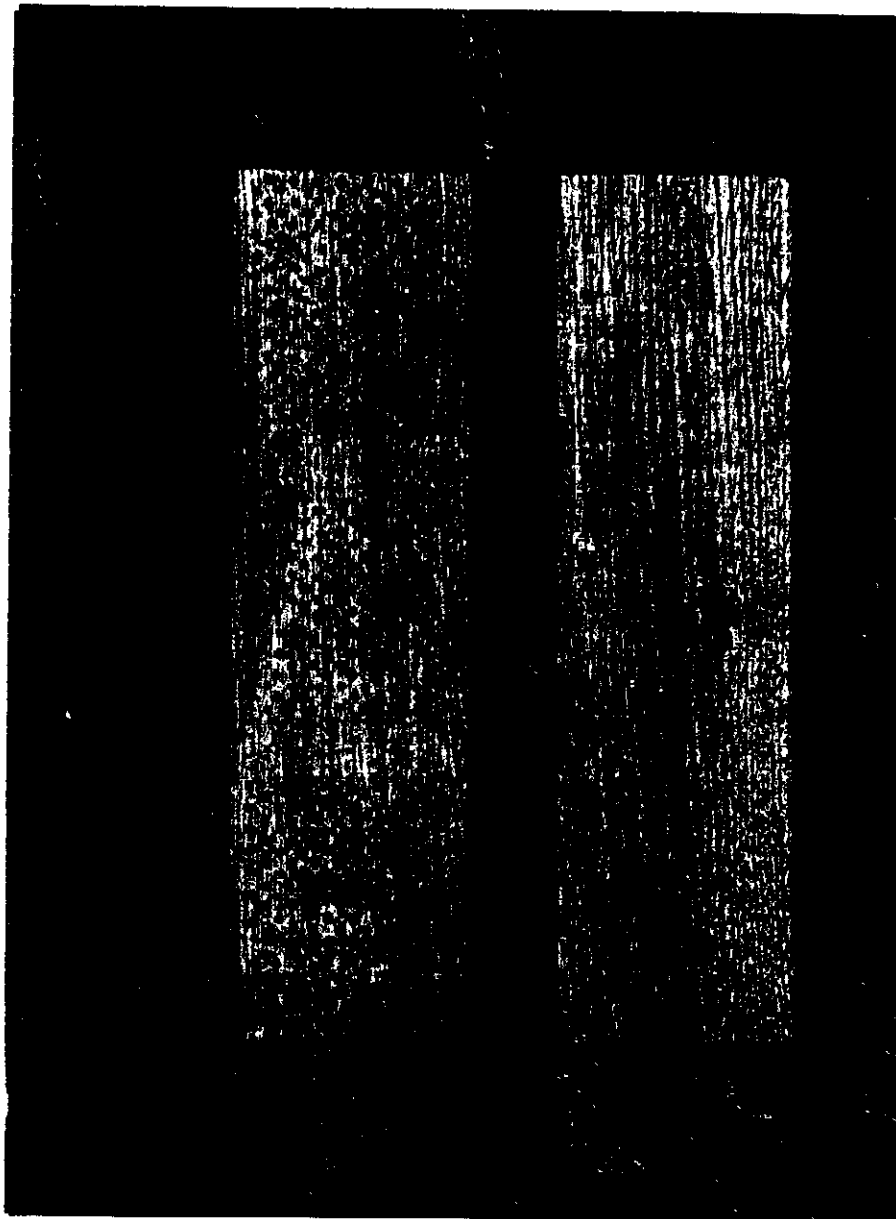

Figure 69. Photograph of the model planks.

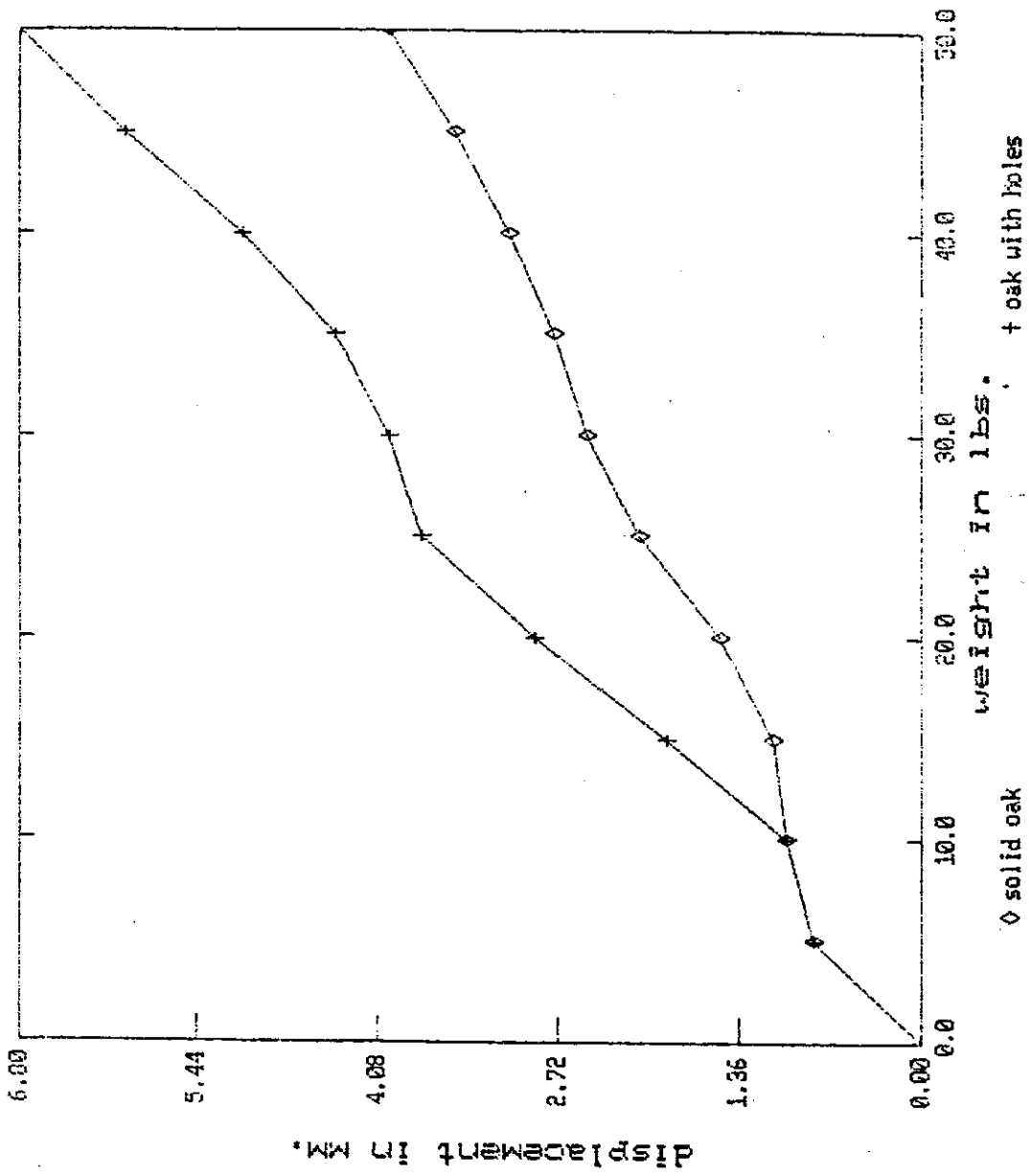

Figure 70. The graph comparing the deflection of the model planks plotted by weight vs. amount of deflection.

As expected, the pierced plank bent further under the weight, which was 58.8% greater at the fifty pound mark. This means that the pierced plank was 58.8% weaker than the intact plank when under 50 lbs. of direct pressure.

A similar weakening of the actual planking of NZ421 can be inferred from this result. While the light framing in the fishwell aided in shoring up the planking, the area would still not have been as strong as the dry areas of the vessel with their larger framing members. However, it must be remembered that the fishwell planking was not subject to as much water pressure as were the dry areas. Thus, there is the implication that, with the reduced water pressure, the forces working on the planking in the fishwell were small enough to make inconsequential the reduction in strength caused by the holes.

Torsional strength would also be affected by the holes. However, twisting would probably be minor on NZ421 since it is unlikely that such a heavily framed vessel would twist substantially, particularly with the bulkheads, sheer clamps and the strongly fastened stringers imparting both longitudinal and lateral stiffness (McGrail, 1978: 128).

Aside from a direct blow on the pierced planking, the planking in the fishwell would not be submitted to much stress beyond the ordinary. Thus, in conclusion, it

appears that a builder would not increase planking thickness on vessels with a fishwell.

### Longitudinal Timbers

The mast step of NZ42i was elongated, but too short to be called a keelson. It laid over eight frames, from frame D to L, and was fastened to the floor timbers with treenails and with nails on its ends. This arrangement rendered additional stiffening to the keelplank in the area of the mast, and distributed the weight and leverage forces of the mast over a large area of the bottom.

There was no central stringer in the stern. A stringer arrangement similar to NZ42i's was found on both NZ44 and W10, although the latter had more stringers than either of the clinker-built vessels. The greater number on W10 was possibly to impart strength lost by the carvel technique. The absence of a central stringer on all three waterschepen may be due to the steep angle between the lower strakes and keelplank in the stern since this construction may have provided more reinforcement to the keelplank than the flat bottom gave the keelplank in the bow. Also, added stiffness may have been unnecessary in the stern since it didn't have to bear the brunt of the waves or beaching.

The ceiling in NZ421's cabin did not contribute to the vessel's strength since it was not fastened. Its sole purpose was to protect the hull from the ballast as the crew walked and sat on it.

The lack of stringers in the fishwell is probably due to the desire to keep the fishwell as uncluttered as possible and was compensated for by the strong bonding between the sides and bulkheads.

### The Caulking

The caulking is typical of the traditional Celtic method found throughout northwestern Europe, to as far east as Novgorod in the U.S.S.R. (Kolchin, 1989: 353). The origins of holding packed moss in place by a wooden lath can be traced back as far as the Ferriby boats on the Humber in England. These vessels, dating to the mid-second millennium B.C., used yew withies instead of iron sintels for holding the laths, but the technique was essentially the same (Wright, 1976: 15, 16, 37).

Perhaps because archaeological finds are limited, iron sintels are not found until the Roman era on vessels such as those found at Zwammerdam (de Weerd, 1978). The sinteling method continued to be used on Dutch vessels even after carvel building began in the mid-fifteenth century (Unger, 1980: 223-4, Reinders, 1986b: 15).

Whatever influence, if any, the Norse tradition had on vessels of the Netherlands, it did not extend into the area of caulking. On Viking ships, such as the Gokstad ship, luting was used between the faces of the landings (Dammann, 1983: 9). While this method has not been found on any vessel excavated from the IJsselmeer to date, vessels with rove-and-rivet fastenings at the landings, instead of double-clenched nails, have been found. The caulking method on these vessels is not known, (Reinders, 1985: 29).

Caulking moss on IJsselmeer wrecks has been found to include animal hair or pitch (van de Moortel, 1987: 115). There is no data on whether the moss used to caulk NZ42i included these elements.

While the size of sintels used in caulking the landings was not recorded, it can be assumed that they were of the same dimensions as those used to caulk the fishwell deck. It is not known whether the spacing of the sintels was the same throughout the vessel.

## The Decks

### Mast Support

Since many wrecks found in the region do not have their decks preserved, only a few parallels to the mast support structure of NZ42i can be found. One such archaeological

find is Kalmar I, which had timbers comparable to NZ42i's kingplanks together with supporting thwarts after the mast (Akerlund, 1951: pls. 7b, 7c). Another parallel is the Ilmenau Ever, a model from 1710, which has a mast support structure with greater similarities to NZ42i. The model (Fig. 71) is of a type first found in literary sources in 1300 (Salemke, 1971: 7) and thus has a history equally long as the waterschip (see below). On this open, flat-bottomed vessel with clinker-built sides, the mast is supported on its after side by a thwart and laterally by two timbers running fore and aft. Forward of the mast, in the top faces of these two timbers, is a rabbet into which fits a mast partner. The mast partner may be similar to the missing one on NZ42i, although it is not known if this item on NZ42i was one piece with the hatch, pump included (see p. 144).

The Ilmenau Ever also has vertical timbers running from the longitudinal timbers to the mast step, with an additional third vertical timber after the mast. The timbers forming this "sheath" or "chute" are fastened at both ends, thereby securing the upper structure to the step (Salemke, 1971: 12). This is in contrast to NZ42i, where the timbers were removable and were apparently used to wedge the mast in the socket and between the kingplanks.

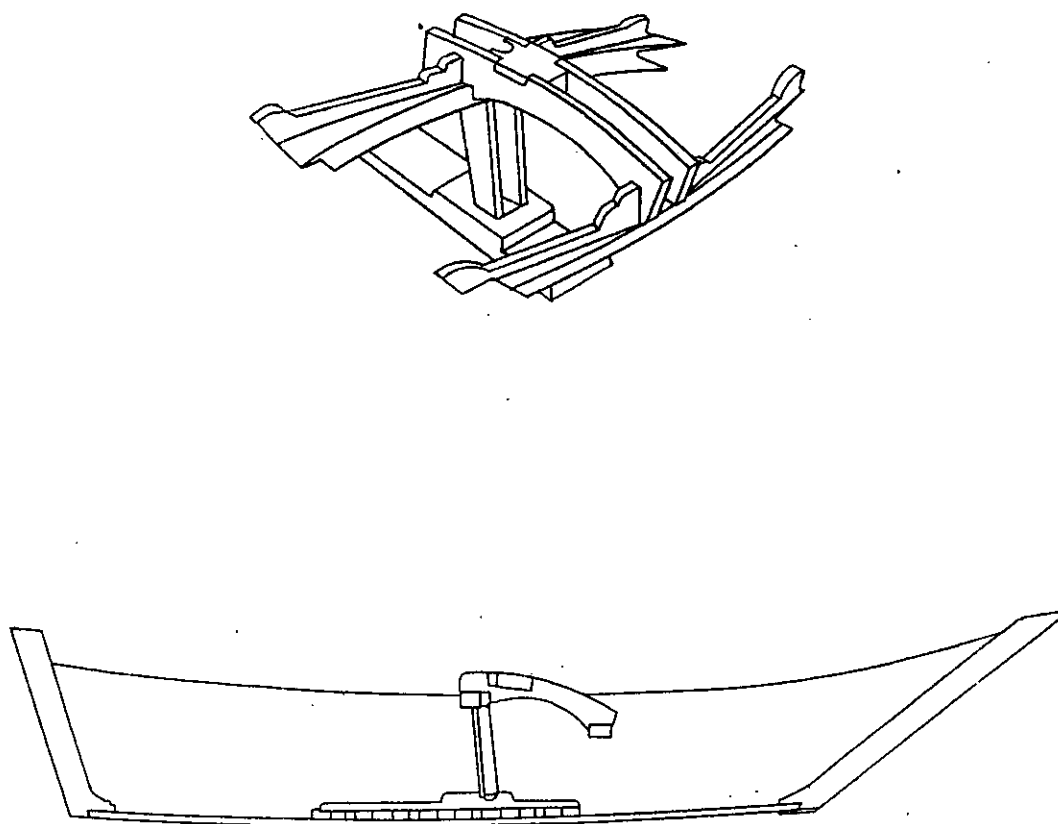

Figure 71. The Ilmenau Ever (after Salemke, 1971: 10, 12).

While such mast wedges were not found on waterschip W10, evidence of this construction has been found on other vessels. Grooves for wedges have been found in surviving mast steps of a number of Greco-Roman ships; for example, the sixth century Bon Porté wreck (Pomey, 1981: fig. 5). The mast step of the 13th century Kollerup cog (Fig. 72) has a rabbet along three sides of the mast socket, which might be for the fitting of wedges or "sheath" timbers, rather than a tenoned mast foot. Similar rabbets were also found on the fifteenth-century wreck Blackfriars 3 (Marsden, 1979: 88). Thus, mast wedges, or the mast "sheath", appear to be widespread in both time and space, indicating an important role in mast support. Undoubtedly, further investigations of IJsselmeer wrecks will yield more data on this structure.

### Constructional Analysis

Although its beams were not fastened to the shelf, the forward deck was integral to the strength of the bow since longitudinal strength was provided by the kingplanks and the waterways. These timbers were attached to the stem via frame Q and connected to the bottom strakes via the forward bulkhead assemblage. Thus, the stem was bound to the bulkhead, and the deck to the hull bottom, forming a rigid system that made the bow

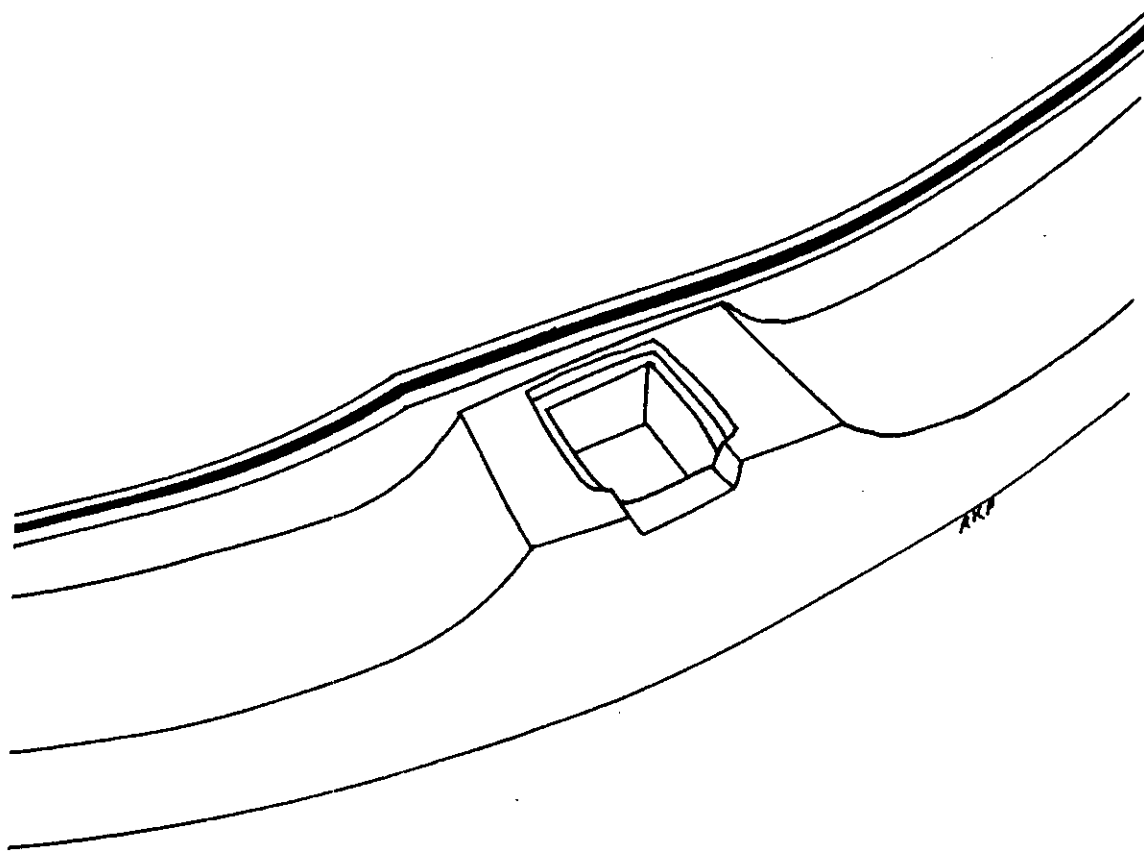

Figure 72. The mast socket of the Kollerup cog (after Crumlin-Pedersen, 1979: fig. 2.11).

inflexible. The decking itself contributed little to the strength of the vessel because of the open areas over the drain, at the hatch and in the area between the kingplanks. So constructed, the decking was only a walking surface.

Decks are usually uncluttered by permanent construction. The decks of NZ421 are unusual because of the obstacles presented by the rider beams. Smooth decks were not unknown, however. For example, in earlier times, the Gokstad ship had removable decking laid flush with the tops of the beams with no overlying timbers (Dammann 1983: 11, fig. 3). However, NZ421 and the other waterschepen had a different construction, with decking fastened to beams combined with the overlying rider beams.

On the fishwell deck, the rider beams served to hold the decking down when affected by the shifting cargo. On the forward deck, however, the rider beams seem to be useless. They were not needed to hold the decking in place since it was firmly fastened to the beams and no forces from below threatened to dislodge it. Also, while the beams were not fastened to the shelf, the waterway firmly attached the deck to the hull by its fastenings to the beams and frames, thus making unnecessary the connection between deck and hull via the rider beams.

While it can be asserted that the rider beams strengthened the deck beams, the construction could have been avoided by using larger beams, if further strength had been necessary.

The presence of the rider beams made the deck a clumsy, dangerous work area. The risk of injury would be compounded in a rough sea, in which an even smooth deck can be difficult to negotiate. The lack of rider beams on the stern deck, on the other hand, demonstrate that decks without rider beams were not unknown to the builders. This deck was clear of obstruction, making it safer for both the helmsman and the men hauling the nets. Additionally, the caulking method on the forward and fishwell decks was unsuitable since the sintels could be kicked out by the men as they worked. This was realized by the builders who used nails in place of sintels on the stern deck. Possibly, the form of the stern deck may be the beginnings of a change in the entire deck structure. But why were the other two decks constructed in such an unsafe, redundant and inefficient manner?

The decks resemble the construction of the flat-bottomed river and lake craft built in the Celtic tradition found throughout Northwestern Europe outside of Scandinavia. The Zwammerdam vessels, the Druten barge and the Lake Neuchatel boat are some of the earliest

examples of this type, dating to the first and second century A.C. These craft were constructed with clinker or carvel-built sides which met the keel-less, flush-laid bottom in a hard chine. The framing on the Druten barge and the Lake Neuchatel boat consisted of pairs of floor timbers each with a vertical knee on one end to support the vessel's sides (Lehmann, 1978: 259, Arnold, 1975: 123-26). The framing arrangement on Zwammerdam 2, however, consisted of a timber with a vertical knee on one end and a futtock scarfed onto the other (de Weerd, 1978: 15-16). The construction of these early boats is similar to the deck construction of NZ42i and, except for the pairing of the timbers, the frames of these vessels resemble the rider beams of NZ42i (Fig. 73). The greatest similarity is found between the fishwell rider beams of NZ42i and the frames of Zwammerdam 2, both of which have a knee on one end and a futtock on the other.

Later vessels with similar construction have been found in the polderlands. The most notable of these is K73/74 whose frames consist of two timbers scarfed near the centerline and with vertical knees on their outboard ends (Fig. 73) (Reinders, 1986: 21).

The similarities between the frames of these vessels and the rider beams of NZ42i point to an adaptation of construction techniques. If one were to remove the

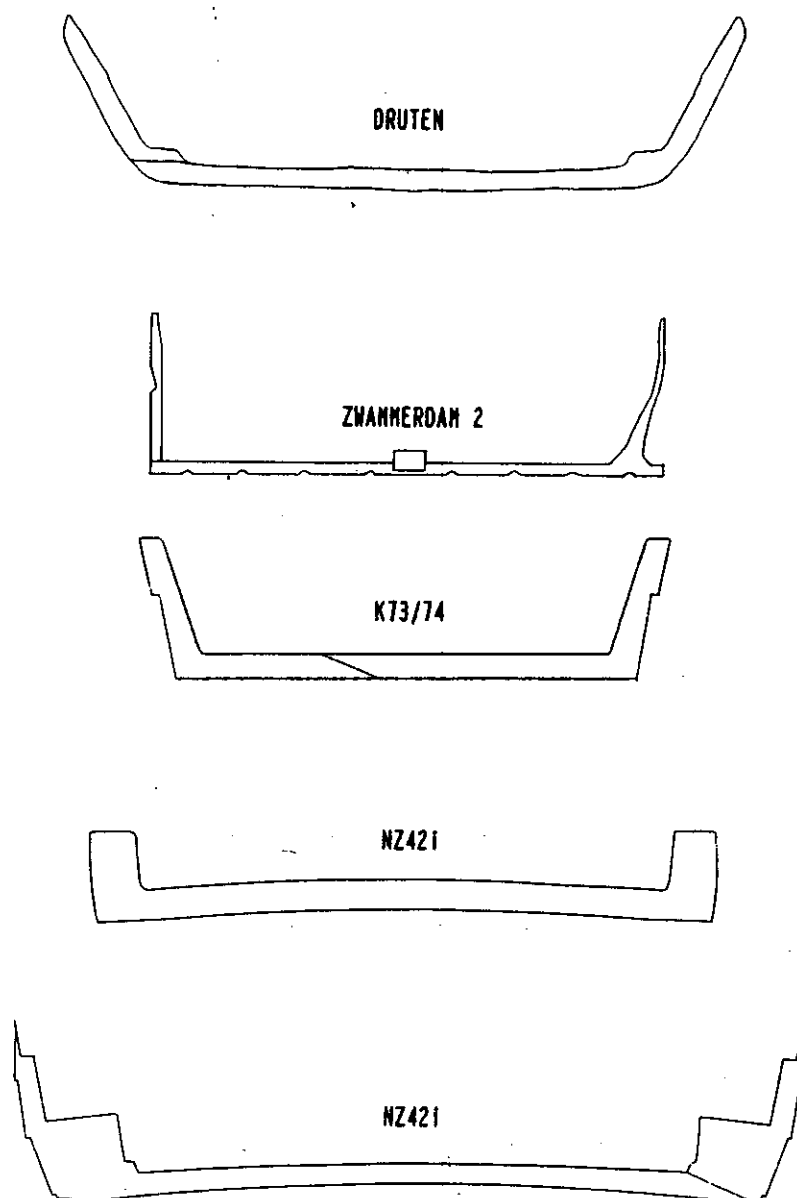

Figure 73. Frames of the Druten barge, Zwammerdam 2 and K73/74 compared to riders of NZ421 (after Lehmann, 1978: fig. 6; de Weerd, 1978: fig. 19 and Reinders, 1986a: app. 6).

forward and fishwell decks from NZ42i and arrange them on an even level, they would appear to be nothing but one of these flat-bottomed barges. Hence, one type of vessel was used to create the decks of another type.

This method may have been used due to caution, tradition and conceptualization. Vessels in earlier times, such as the Graveney boat and Sutton Hoo, were undecked (McKee, 1978: fig. 10.1.2, Bruce-Mitford, 1975: 424). Therefore, the closing over of the hold necessitated either creating new and untried techniques or drawing on known construction methods. A technique of building a flat walking surface was found in the river barges, and the easier, more cautious, route was chosen. The form of the barge was adapted to fit on top of another type of vessel. The kingplanks, which may have been part of the superstructure of undecked vessels, as on Kalmar I, were left in place and the bottom of the barge was adapted to fit around them.

Thus, a flat-bottomed barge was effectively placed on top of a sea-going vessel which later evolved into the waterschip. The bottom of the barge became the decking, its frames rider beams; and its hard chine, the juncture of the deck and the sides. Above the fishwell where there was no framing, the vertical knees of the floor timbers, now rider beams, continued to support the sides.

On the forward deck, where the framing continued past deck level, the vertical knee remained as a redundancy.

The concept of "stacking" one vessel on top of another is not unique to this work or to waterschepen. Detlev Ellmers has a similar theory to explain the construction of cogs. Ellmers (1979: 9) points to the "Havelkahn" of Berlin-Spandau, which was constructed with bulkheads instead of frames:

...(B)ulkheads from the very beginnings of their development played an essential role in the construction from the logboat to the Cog of Bremen. With her we find the bulkheads not down in the hold but on top of the cross-beams as a support for the deck-construction. The shape of these bulkheads is... very much the same as those from the "Havelkahn". This observation leads to the ideas that the big seagoing Cog of late medieval date is something like two ships, one on top of the other with the crossbeams marking the transition. Indeed there is much to support this hypothesis. Not that people really put one ship on top of the other, but in order to increase cargo-capacity they doubled the height of the side. They used their experiences with ships of half this height in so far as they repeated their methods when starting to construct the upper half...

On the Bremen cog, after the bottom and sides were built to the level of the crossbeams:

(o)n top of the fourth side-strake they put four of the big cross-beams- so to say, as bottom timbers of the

"second ship"- and then continued with the next four side-strakes which they supported from the inside by the upper parts of the ribs and by four bulkheads on top of the four cross-beams....

To prove the hypothesis...we have to look for cog-like vessels with sides half as high (Eilmers, 1979: 11).

Eilmers used the model of the Ilmenau Ever to prove his point. Its cross-beams, placed near the sheer, were roughly at the same height as those on a cog. He claimed this demonstrated that the cross-beams were the uppermost construction on the first, or lower, vessel and that construction above them would have been the second vessel (Eilmers, 1979: 11). Thus, a process not unlike that described for the waterschip's decks was used to develop the cog and as such reinforces the theory for the waterschip's deck construction.

While shape and construction of the vessels are different, a comparison between sections of NZ42i and the Bremen Cog (Fig. 74) demonstrates that the bulkheads above the beams on the cog section not only have a similar function to the rider beams of the waterschip but also that the bulkheads exhibit the stylized shape of a timber with a vertical knee on each end.

Thus, not only do two different medieval ship types exhibit the "stacking," or "piggybacking," of vessels,

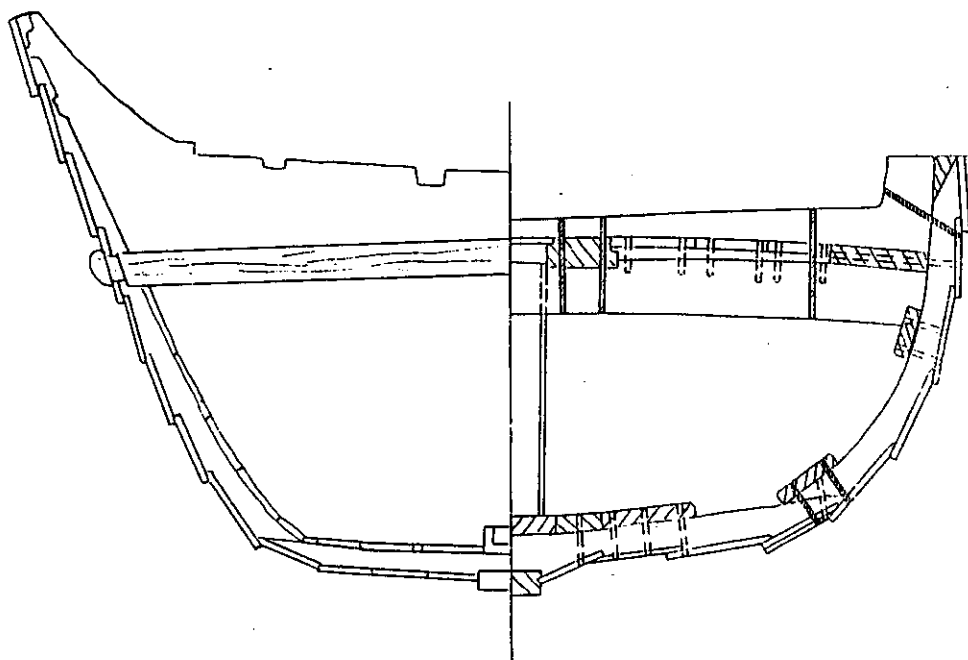

Figure 74. Comparison of a section of NZ421 and a section of the Bremen cog (cog section after Steusloff, 1983: 201).

but the question can be raised whether the cog is indeed "one early cog on top of another" (Ellmers, 1985: 83) or rather, ultimately, a flat-bottomed barge, minus its bottom planking, on top of a cog.

## BALLAST

The analysis of the ballast was undertaken by the RIJP. The results are reported here without modification.

The ballast assemblage consisted of stones from the three main sources for stone material in the Netherlands.

The three sources are:

- Northern or glacial material from moraines dating to the Ice Age.

- Southern material from the Rhine.

- Southern material from the Maas in Belgium and Northern France.

The southern material was smooth and rounded from the action of the rivers, while the northern material was rough. The Northern material included stones such as granite, diorite, basalt, sandstone, flint and chalk, among others.

Also included in the northern types were stones from Scandinavia such as Uppsala granite and Larvikite. Stones such as these are only found in specific locales, the former in Uppsala, Sweden and the latter around the

town of Larvik near the mouth of the Olsøfjord in Norway. Therefore, their origins cannot be mistaken. There were no stone types present from the eastern Baltic regions.

The southern material included quartz, quartzite, sandstone, basalt and windkanters (stones eroded by the wind), among others. This material accounted for 29% of the total ballast, with stones from the Rhine outnumbering those from the Maas almost 3 to 1. The sandstone and the quartzite originated in Germany while the six stones from the Maas point to a western Veluwe origin. The four windkanters are of the type found in the area around Huizen in the Gooi where the Utrecht-Gooi hills reach the Zuider Zee coast (Fig. 75).

The RIJP report concluded that the material must have been collected in the area between Harderwijk and the Gooi, with an origin near Huizen most probable.

It should also be stated that the presence of material from Scandinavia does not imply that the waterschip ranged that far. It only suggests that parts of the ballast were brought to the Netherlands by other vessels, either as their own ballast or as material for other uses such a dike construction.

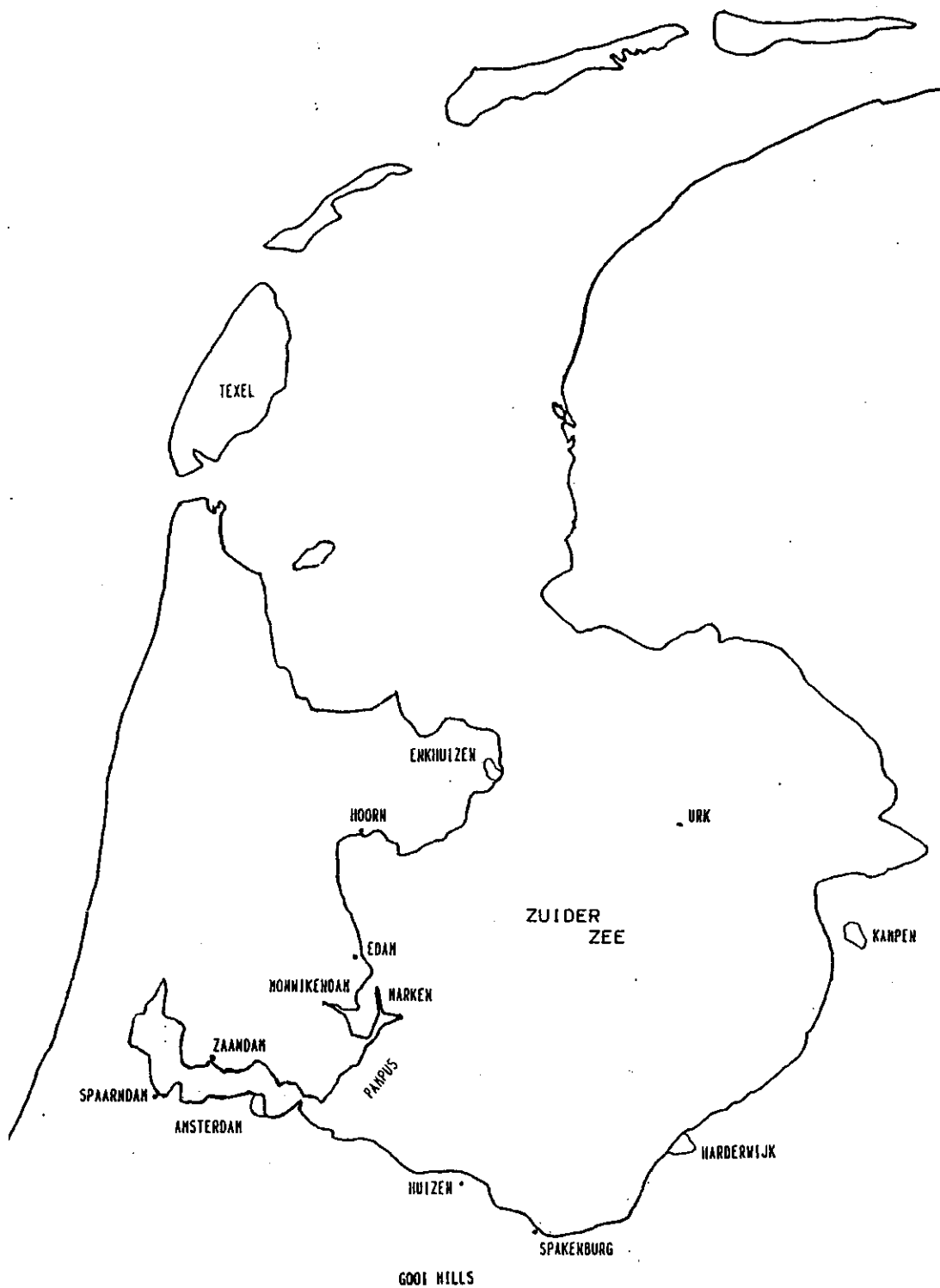

Figure 75. Map of the Netherlands with the source of ballast and important fishing towns shown.

### Artifactual Remains

While a full analysis of the artifacts is beyond the scope of the present work, a general analysis can be made in order to illuminate ship-board life.

The floor tiles undoubtedly formed a hearth similar to the one found in the cabin on waterschip W10 (Reinders, 1986b: 25). Set on the ballast, the hearth would be out of contact with the wood of the vessel.

The various cooking pots, pitchers and remains of utensils reveal that the vessel was well equipped to feed the crew. The types of bones found, i.e., cow, pig and fowl, show that the crew ate heartily while at sea and did not have to subsist off their catch. The cooking vessels and plates were utilitarian in nature as is evident from the coarse earthenware fabric.

The presence of the many shoe pieces can only be speculated upon. Possibly, worn out shoes were simply discarded in the bottom of the vessel instead of jettisoned. However, it is also possible that the shoes were being recycled for their leather to make things needed for the vessel or its tackle. Perhaps an investigation into medieval leather objects would yield information on this.

### NZ421 and Comparative Waterschepen

The dimensions of eight waterschepen are presented in table 2. While Ympa gives slightly different metric figures for the vessels from 1638 and 1736 (Ympa, 1962: 44), the figures presented here are based on 1 Amsterdam foot equalling 28.3 cm. (Verhoeff, 1983: 4).

As can be seen from the data, only a range of dimensions can be assigned to the type. Only the model in the museum is shorter than NZ421, the lines of the 19th century vessel represent the only one with less beam and only the waterschip from 1736 has less depth than NZ421. There is no pattern in the dimensions as they pertain to size changes through the centuries. The differences in the dimensions may be due to the period, location of construction, or to the demands of the buyer. Perhaps an investigation of builders' records would provide data on this. Until then, it can only be concluded that while the form of the waterschip stayed the same, its dimensions were flexible, even in later centuries when ship design and plans became the norm.

Table 2. NZ42i and comparative waterschepen.

<u>Name</u>	<u>Length</u>	<u>Beam</u>	<u>Depth</u>	<u>L:B</u>	<u>L:B:D</u>	<u>Reference</u>
NZ42i	17.28	5.02	1.98	3.44:1	8.7:2.5:1	
W10	19.7	6.34	2.6	3.1:1	7.5:2.44:1	Reinders, 1966b: 21
Vessel of 1638	16.98	5.24	2.4	3.24:1	7:2.2:1	Hart, 1952: 153
Vessel of 1736	20.4	6.26	1.95	3.26:1	10.5:3.2:1	Hart, 1952: 153
Early 19th cent. lines	21.75	5.87	2.26	3.7:1	9.6:2.6:1	Nederlandsch Historisch Scheepvaart Mus., 1943: 127
Marker vessel	18/21	6/6.75	2.95	3:1/ 3.1:1	6.1:2:1/ 7.1:2.3:1	le Comte, 1831: 41
Model in Amst. Museum	17.2	5.6	2.8	3.1:1	6.1:2:1	Crone, 1926: 243

## Chapter VI

THE WATERSCHIP: ITS HISTORY AND ORIGINThe History of the Waterschip

Waterschepen were the largest of the Zuider Zee fishing vessels (van Beylan, 1970: 150). The earliest mention of the type dates to 1339, where a waterschip was being used for the transport of fresh fish in Amsterdam.

Apparently, their role as fishing vessels developed at a later date (Ypma, 1962: 44). Although principally a Zuider Zee vessel, there is mention of a waterschip used in trade with England in the year 1420 (Ypma, 1962: 44).

In later times, the waterschip acquired the role of tugboat. The earliest mention of this dates to 1598 (Reinders, 1986b: 33). The vessels were well suited to this task due to their great stability. The acquisition of this role was made necessary by the Age of Exploration coupled with the growth of international trade. During this era, ships grew larger and, because of their deeper drafts, could no longer safely navigate the shallow area of the sea near Amsterdam known as the Pampus (van Beylan, 1970: 150). The waterschepen were used to tow the East Indiamen, and other large ships, to areas of the sea where they could navigate without danger.

In addition, the waterschepen were used as lighters for the removal of cargo and ballast from large ships so that they could float high enough in the water to clear the Pampus. Often, especially in later times, this was accomplished with the aid of scheepskameelen (= ships camels) (Fig. 62). Regulations from 1526 stipulated that a ship passing the shallows could have a maximum draft of 5.25 Dutch ells, which is approximately 4.8 meters. The regulations were enforced by a paalmeester, and violators were fined 50 guilders (Crone, 1926: 240). Ships with drafts deeper than the maximum allowable draft needed lighters to avoid trouble. Eventually, the waterschip was recognized as ideal for the job.

In the nineteenth century slack tide depth in the Pampus was 2.7 m., high tide was 3.15 m., and the highest tide was 3.9 m. (le Comte, 1831: 38). These figures are lower than the maximum allowable draft in the sixteenth century and indicate a siltation problem in this area of the sea. This would compound the problem of safe navigation, since the sea was becoming shallower as the ships were becoming larger. Nevertheless, even the least of these depths yields ample clearance for the passage of a laden waterschip.

Another use of the waterschip was as an armed vessel. A painting from 1573 by H.C. Vroom depicts such a

waterschip. Shown with a cannon and soldiers aboard, this vessel may have played a role in the naval battles of the Eighty Year War (Reinders, 1986b: 31).

Waterschepen were also armed in the Napoleonic era when they were fitted with two pairs of light and heavy guns for the defense of the Y during the years 1799-1805, 1807 and 1809 (Petrejus, 1971: 118). Additionally, between 1811 and 1813, almost all waterschepen were in the service of the navy (Crone, 1926: 242).

Although many waterschepen were used for non-fishing purposes, others continued to be used as fishing vessels through the eighteenth century. Towns which continued to use the vessels for fishing were Hoorn, Zaandam, Marken, and Uitdam. One such model of a late, fishing waterschip can be seen in the Nederland Museum (Crone, 1926: 242).

During the latter half of the seventeenth century, anchovy fishing became an important enterprise as saltwater fish became prevalent due to a change in the salinity of the Zuider Zee. Waterschip depictions of that century (Figs 45, 46) portray waterschepen at work with their large nets. The earliest mention of their connection with anchovies dates to 1736 when the fishwell was called an ansjovisvat (Ypma, 1962: 22).

Apparently, only one feature was changed to adapt the waterschip to its different functions: the ones used as

tugs and lighters did not have the pierced planking that made the central part of the hull a fishwell (Crone, 1926: 242). This area was kept dry on these vessels for the transport of cargo and ballast, which could amount to as much as 11 tons on a vessel the size of NZ42i.

The importance of the waterschepen as tugs and lighters is underscored by the creation of two companies in the eighteenth century whose sole purpose was to tow and load other ships. One of these companies had a fleet of 15 waterschepen and, beginning in 1741, was under exclusive contract to the admiralty and the Dutch East India Company. These vessels carried the admiralty's coat of arms on their stems and, later, on their sails. The other company had only three waterschepen and serviced various other ships (Crone, 1926: 241).

The maintenance costs of a fleet of tugs and lighters must have been considerable. Other expenses connected to the waterschip fleets would have included the crews' wages and the time needed to load the small vessels, carry the goods to the ship or to port and then unload. Undoubtedly, this expense, although necessary, would have been disliked by the shipping companies. The system was ultimately circumvented by the digging of the Noord-Hollands canal, which opened for service in 1825. Via this canal, fully laden ships could sail directly from

Amsterdam to the North Sea without fear of running aground (van Beylan, 1970: 151).

No longer needed, the waterschepen fell into disuse (van Beylan, 1970: 151), and the fleets were sold for scrap in 1827 (Crone, 1926: 242). The type disappeared shortly thereafter only to be remembered in models, engravings and through the archaeological discoveries of the late twentieth century.

Why the waterschip did not survive as a fishing vessel is a matter of speculation. It is possible that other fishing vessels such as the tochtschuit, a smaller vessel which may have developed from the waterschip (van Beylan, 1970: 150), were so well entrenched in the maritime economy that there was neither need nor room for the large waterschip. It is also possible that by the early nineteenth century, the design of the waterschip was considered dated. In either case, the specializations which enabled it to survive as a type for five hundred years were ultimately the cause of the waterschip's obsolescence.

### The Origin of the Waterschip

The waterschip originated in Amsterdam and in the Zuiderwoude in Waterland. Later, the type spread to the Zuider Zee towns of Spaarndam, Monnikendam, Edam, Hoorn,

Enkhuizen, and Harderwijk (van Beylan, 1970: 150) as well as Marken, Zaandam, Uitdam and the other towns mentioned earlier.

The origin of the waterschip is not clear. It has been suggested that it was developed from the cog (van de Moortel, 1987: 174), but such a view may rest primarily on the fact that, of the three major medieval ship types of northwestern Europe, i.e., cogs, hulks and keels, the cog is the best known due to iconography and numerous archaeological finds. At present, no actual hulk or keel has been identified as such with certainty, and the only inferences that can be made about them are based mainly on artistic representations. Nevertheless, the possibility of a cog origin for the waterschip merits examination.

Features typical of a cog included: through-beams with bulkheads placed above them; a sharp, high bow and stern; strakes which were made flush rather than overlapped towards the ends by sculpting or beveling the seams; a flat, carvel-built bottom; steep, straight, clinker-built sides; a straight stem and post which met the keel in a sharp angle; hooks at either end of the keelplank; inner posts; posts made from two pieces and sinteling. Ellmers (1985: 81) states that these cog attributes are "...part of a technical system that always produced every time the

same pattern of hull shape in a very limited range of variation under which the Bremer Cog is by far the most developed example..."

Although waterschepen and cogs share some attributes such as the fastenings, the sinteling, the keel-less construction and the sharp transition between sternpost and keelplank, the differences outweigh the similarities. The shared characteristics are minor and can be attributed to the general building technology of the region. Unlike the cog, the waterschip has a low stern, a bluff bow with a convex stem, no through-beams, no inner posts, no hooks at the keelplank's ends, and is clinker-built throughout. Thus, with none of the major characteristics shared between the two types, there is nothing to substantiate the suggestion that the waterschip is a descendant of the cog.

However, there is one medieval artifact that is reminiscent of the waterschip. This is the Ebersdorf ship model (Fig. 76). This model, although claimed to be a cog (Steusloff, 1983: 189), shares only a few characteristics with cogs, such as the through beam/bulkhead combination. Unlike cogs, the model is clinker-built throughout, has a convex stem and a straight post, has no hooks at the keel ends and contains no inner posts. Other features of the model include

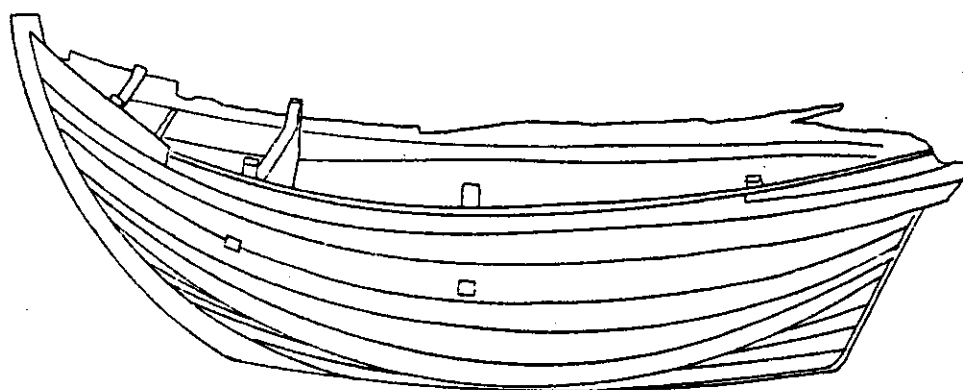

Figure 76. The Ebersdorf model (after Steusloff, 1983: 191).

planking with 2 to 4 planks per strake, a keel instead of a keelplank, garboards which roll into the ends and a shape which is full at the bow, wide amidships and sharp astern. These features, except for the keel, are shared with the waterschip.

A comparison between sections of the Ebersdorf model and NZ42i illustrates their similarities (Fig. 77). Without the through beam and the keel, the Ebersdorf section is similar to the waterschip section. They both are clinker-built throughout, have futtocks placed on top of floor timbers and have timbers placed above the beams extending to the sheer. The model's profile is also similar to that of NZ42i (Fig. 76). While it lacks the waterschip's low stern, the model's stern is lower than its bow, and the shape of its forward section, as well as its pronounced sheer, resemble NZ42i. These similarities demonstrate an affinity between the two vessels, and it can be asserted that the waterschip is a variation of the type represented by the model.

The Ebersdorf model has been dated based on legend and constructional features to A.D. 1400, predating NZ42i by at least 100 years. The provenance of the model, other than the cathedral in which it was found, is unknown, although it is believed to have originated in the Baltic or the North Sea regions (Steusloff, 1983: 205). Thus,

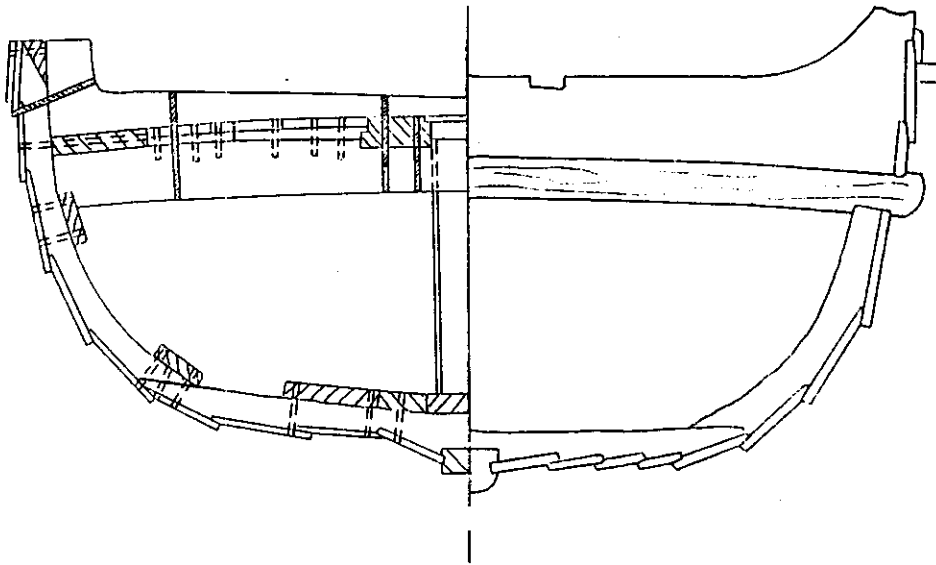

Figure 77. Comparison between a section of NZ42i and a section of the Ebersdorf model (Ebersdorf section after Steusloff, 1983: 201).

the type represented by the Ebersdorf model may have been known in the Zuider Zee, giving the Dutch the opportunity to adapt it to their needs.

Steusloff states that the model is representative of the type of cog which is the result of the blending of cog and hulk types around the end of the fourteenth century. This in turn blurred the distinctions between the two types (Steusloff, 1983: 204). He also believes that the convex stem of the model represents a regional cog variation rather than a change in the type (Steusloff, 1983: 202): "Der leicht gerumnte Vorsteven sowie die im Vorschiff hochgezogenen oberen Plankengänge des Modells konnten sowohl einer typologischen Annäherung von Kogge und Hulk entsprechen als auch auf die mecklenburgisch-lubische Bauform der Kogge hinweisen. (The lightly-curved stem post of the model, as well as the upper strakes sweeping up in the bow, can correspond to a typological approachment of cog and hulk as well as point to the Mecklenburg-Lubeck type of cog)" (translation anonymous; Steusloff, 1983: 204). This accounts for the sharing of some characteristics between the model and the cog.

However, since the form and construction differs radically from the cog, the model is more closely related to the hulk, or may even be an example of this

historically-important ship type (F. Hocker, personal communication). Early characteristics of hulks, as ascertained from iconography, include: a pronounced sheer, with the forward end higher than the aft; an easy transition from the bottom to the ends; absence of posts; and a rounded cross-section and profile (Ellmers, 1984: 59). In later times, the hulk developed posts and a straighter keel-line as the distinct cog and hulk attributes blended (Abel, 1969: 68).

The similarities of the hulk to the Ebersdorf model and the waterschip are apparent. While the transition between their posts and keel/keelplank is angular, the transition into the stem is gradual on both. They also have their bows higher than their sterns and rounded cross-sections. Thus, rather than having a connection to the cog, the waterschip may be a derivative of the hulk.

Additionally, the comparisons with other vessels mentioned in previous chapters, such as the Graveney boat, point to the connection of the waterschip to the regional traditions and technology known as Celtic, to which the hulk also belongs. Hence, Zuider Zee traditions are an offshoot of Celtic shipbuilding.

As alluded to in chapter 5, the type may also have connections to southern Europe, exemplified by the fishwell and mast wedges. While such features may only

be independent inventions to cope with similar needs and problems, it must be remembered that the Netherlands was once part of the Roman Empire. Although Roman influence cannot be proven at present, it is a possibility that cannot be dismissed without further evidence.

Essentially, however, the waterschip is apparently a hulk-like vessel built in the Celtic tradition with the unique qualities of Dutch shipbuilding methods.

## CHAPTER VII

## SUMMARY AND CONCLUSIONS

## The Change to Carvel Construction

Due to the limited number of studied waterschip wrecks, it is difficult to define characteristics typical of the type except for those seen in artistic representations. Consequently, the shared characteristics of NZ42i and W10, other than those confirmed by representations, must tentatively be considered standard for the type until future research proves otherwise.

Likewise, while NZ42i exhibits the typical waterschip form, it is difficult to determine which of its features are idiosyncratic. Until other clinker-built waterschepen are examined, the features of NZ42i must be assumed to be standard for this type of waterschip.

In comparison to NZ42i, W10 does not appear to be markedly different, except for the obvious carvel construction. The similarities between the two include: the profile; the shapes of the stem and sternpost; the fishwell construction including the bulkheads, frames, deck and trough; the overall deck construction; and the gordijn (p. 139). However, there are numerous differences between the two vessels. Some of these illustrate the changes in construction and the form of

the waterschip when the carvel technique came into use in the Netherlands. The differences found on W10 include:

1. The longer scarf joining the stem and keelplank.

The length was increased to give greater strength to the joint (p. 155).

2. Thicker planking. Planking on a carvel vessel is thicker (p. 168).

3. Frames placed closer together. This may or may not be attributable to the new technique (p. 180). However, since the two waterschepen are apparently close in age, it is likely that the closer framing is indicative of adaptation to the new construction method rather than evolution.

4. Frames scarfed on their sides (p. 182).

5. More stringers. The additional stringers on W10 probably provided strength lost by the use of carvel planking (p. 193).

6. Greater deadrise- On NZ42i, the angle of deadrise amidships is 10 degrees. On W10, the angle of deadrise is 20 degrees (Reinders, 1986b: app. 11), which is due in part to the steeper angle of the garboards in relation to the keelplank. Amidships on W10, the garboards sit at an angle of 32 degrees to the keelplank (Reinders, 1986b: app. 11), while on NZ42i the angle is 25 degrees. It is possible that the greater deadrise of the carvel-built

vessel is due to different builders or location. However, it is likely that it is one of the changes brought about by the switch to carvel construction, since flexibility of design rendered by the new technique would have made a more complex hull-form possible. Also, in the carvel-built hull, where the planking does not impart the strength of clinker-built planking, the steeper garboards would give the keelplank additional stiffness. In the clinker-built hull, the planking and the landings would give greater strength to the bottom of the vessel, thereby making possible a flatter bottom. Hence, the sectional form of the waterschip may have been changed to adapt the type to the carvel technique.

7. A straighter sheer-line. This probably has no connection to the change to carvel construction.

8. A relatively larger stem. While the stem of W10 is larger than that of NZ42f, this is in part due to the larger size of the former vessel. However, the proportional size, that is, its molded dimension relative to its height, is also greater. This may be attributable to the need for a stronger stem in W10's carvel-built hull.

9. A more sophisticated stem construction. This is either due to the later date, or to the need for a stronger stem.

10. A forward deck without kingplanks or open spaces. The kingplank construction is not found on W10, nor are the open areas in the decking over the gutter and in front of the mast. These may be evolutionary changes. There is certainly no reason why kingplanks could not be used in the deck of the carvel-built vessel. Their absence, however, may have made the closing of the open areas necessary in order to reinforce the bow structure via the deck planking. This is unlike NZ42i, where the forward deck planking was simply a walking surface. As such, the additional deck planking is an attribute of the change in deck construction, but not of the change to carvel construction.

11. A longer cabin. This has no bearing on the change in construction technique.

Thus, of eleven differences in construction, eight can be either directly or indirectly attributed to the change from clinker to carvel construction. As more waterschepen are reconstructed and studied, it will become possible to separate general waterschip characteristics from peculiarities of individual vessels. This will enable researchers to define further which attributes are due to the change in shipbuilding technology.

### Zuider Zee Shipbuilding and Waterschepen

Again, the limited amount of data concerning the IJsselmeer wrecks proscribes any far-reaching compilation of the construction features of NZ42i to fit into a "tradition." However, as mentioned in chapter V, the broad, close frames and the high planking scarf gradient may belong to such a grouping. Also to be considered for inclusion are the runners, which are apparently unique among published wrecks. It is possible that they were a standard feature of the clinker-built waterschip.

Whether they have been found on others of this type is not known, although no similar timbers were found on W10.

The major features of NZ42i, such as the clinker-built hull, stem and sternpost, keelplank, caulking, double-clenched nails and deck construction are part of the broader Celtic shipbuilding tradition. Hopefully, further publications will aid in determining Zuider Zee traditions as they pertain to waterschepen.

### The Literary Evidence

The waterschip was an important vessel in nautical history, because it aided the expansion of the Netherlands into a world-wide empire by helping make possible for her large ships to reach the sea. It is therefore surprising how little has been written about

the waterschip. One can find many detailed depictions and descriptions in art and literature of other fishing vessels, such as the herring buss which was the major Dutch vessel involved in herring fishing. Also to be found are vessels such as the jacht, pink and mud barge. The waterschip, by comparison, seems to have been all but ignored. Authors discussing late medieval ships and boats of the Netherlands devote several pages to busses, pinken, smaken and dogbooten, but only a paragraph at best to the waterschip. This is usually placed in a section entitled "Other Types" (van Beylan, 1970: 147). The latest example of the inadequate treatment of the waterschip is found in the late Peter Throckmorton's last book, which includes the depiction by Reinier Nooms and a photograph of a waterschip excavation, but contains only a few cursory lines of text about the type (Martin, 1987: 138). Similar treatment can be found in older texts. Witsen (1690: 188), in his treatise on late seventeenth-century shipbuilding, devotes but a sentence to the waterschip: "De tweede zyn Smakswyze opgebouwt, en voeren een gaffel (The second was built like a smack, and carried a gaff-rig)."

In addition, there is erroneous information concerning the waterschip. This is the result of either confusion with another vessel also called waterschip, which was

little more than a barge used to bring fresh water to the breweries, or through confusion with other fishing vessels, such as the buss (Ypma, 1962: 45). There are also errors concerning the absence of leeboards on waterschepen. In one source, early twentieth century drawings of waterschepen include leeboards (Tesch and Veen, 1933: figs 51, 52, 53), while in another, a small fishing vessel with leeboards seen in a seventeenth-century engraving is identified by modern authors as a waterschip (de Groot and Voorstman, 1980: Fig. 19).

It is logical that the Dutch artists and writers of old would chose to depict the vessels which brought prosperity and prestige to their land, rather than working vessels with as much glamour as a modern step-van. This however, does not explain why other fishers enjoyed greater popularity. Some artists, however, like Rainier Nooms and Balthisar Florisz did pay heed to the mundane waterschip, and their drawings have indeed proved valuable to the present work.

#### Future Research

While drawings from past centuries are useful, they could not be used for determining the date of NZ42i, since the form of the waterschip changed little over the centuries. Also, it was not possible to determine the date by

constructional features because of the paucity of published data concerning medieval Zuider Zee wrecks. Thus, the date presented was based solely on sintel shape. This, however, could be refined through scientific testing. Funding permitting, it would be interesting to see what date a radiocarbon test would yield. Also, samples should be taken from the timbers for dendrochronology.

It would be interesting to collect data concerning dimensions, plank thickness, scarfs and frame spacing from all waterschip wrecks and compile the information in a database system. The large number of waterschip wrecks presents an opportunity for studying details of construction changes, while limiting the study to one vessel type, as has been done with Viking vessels. Such a compilation may provide a dating model, as well as illuminate trends in medieval shipbuilding. This in turn could be used to predict constructional features of wrecks and aid in reconstruction.

Many questions remain about the nearly forgotten waterschip. The reconstruction of NZ42i has answered some. Waterschip NZ44 will be reconstructed by the author for future publication, and a comparative study of the three waterschepen will be made.

The discoveries of various waterschepen in the IJsselmeerpolders provide archaeologists with an opportunity for the study of a medieval shiptype rivaled only by the studies of the Viking ships and the cog. With further reconstruction studies, a better picture of the type will be made available, which will enable the definition of a group of constructional characteristics for the waterschip.

## NOTES

1. NZ42i is the code assigned to the wreck by the investigators.

## REFERENCES

- Abel, H., et al, 1969, Die Bremer Hanse-Kogge. Verlag Friedrich Röver, Bremen.
- Åkerlund, H., 1963, Nydamskeppen: En Studie I Tidig Skandinavisk Skeppsbyggandskonst. Sjöfartsmuseet, Goteborg.
- Anderson, R.C., 1982, The Rigging of Ships: In the days of Spritsail Topmast 1600-1720. Cornell Maritime Press, Centerville, Maryland.
- Arnold, B., 1975, The Gallo-Roman Boat from the Bay of Bevaix, Lake Neuchâtel, Switzerland. International Journal of Nautical Archaeology, 4.1: 123-126.
- Beylan, J. van, 1970, Schepen van de Nederlanden. P.N. van Kampen & Zoon N.V., Amsterdam.
- Beylan, J. van, 1978, De Hoogaars: Geschiedenis en Bouw. Unieboek bv, Bussum.
- Bruce-Mitford, R., 1975, The Sutton Hoo Ship-Burial. British Museum Publications, Ltd, London.
- Bruijn, J.R., 1985, The Timber Trade. In A. Bang-Andersen, et al (Eds.), The North Sea. Norwegian University Press. Oslo: 123-35.
- Comte, P. le, 1831, Afbeeldingen van Schepen en Vaartuigen, in Verschillende Bewegingen. F. Kall, Amsterdam.

- Crone, G.C.E., 1926, Nederlandsche Jachten, Binnenschepen, Visservaartuigen en daarmee verwante kleine Zeeschepen, 1650-1900. Swets & Zeitlinger, Amsterdam.
- Crumlin-Pedersen, O., 1979, Danish Cog-Finds. In S. McGrail (Ed.), Medieval Ships and Harbours in Northwest Europe. BAR International Series, 66: 17-34. National Maritime Museum, Greenwich.
- Dammann, W., 1983, Das Gokstadshiff und Seine Boote. Arbeitskreis Historischer Schiffbau E.V., Heidesheim.
- Department of the Navy, 1957, 1958, 1962, Wood: a Manual for its Use as a Shipbuilding Material. Republished in the first collected edition, Teaparty Books, 1983, Kingston, Massachusetts.
- Ellmers, D., 1979, The Cog of Bremen and Related Boats. In S. McGrail (Ed.), The Archaeology of Medieval Ships and Harbours in Northern Europe. BAR International Series, 66: 1-15. National Maritime Museum, Greenwich.
- Ellmers, D., 1984, Frühmittelalterliche Handelsschiffahrt in Mittle- und Nordeuropa. Karl Wachholtz Verlag. Neumünster. Second edition.
- Ellmers, D., 1985, Frisian and Hanseatic Merchants Sailed the Cog. In A. Bang-Andersen, et al (Eds.),

- The North Sea. Norwegian University Press. Oslo: 79-96.
- Fenwick, V., 1978, Structural Evidence for the Origin of the Ship and Comparison with Other Early N. European Ship-Finds. In V. Fenwick (Ed.), 1978, The Graveney Boat: A Tenth-Century Find from Kent. BAR British Series, 53: 193-264. National Maritime Museum, Greenwich.
- Groot, I. de & Voorstman, R., 1980, Maritime Prints by the Dutch Masters. G. Fraser, London.
- Hart, S., 1952, Het Waterschip. Maandblad Amstelodamum, Amsterdam: 153-54.
- Hart, S., 1977, Scheepsbouw. Maritieme Geschiedenis der Nederlanden, De Boer Maritiem, Bussum: 72-77.
- Kolchin, B., 1989, Wooden Artefacts from Medieval Novgorod. BAR International Series, 495(ii), Oxford.
- Leather, J., 1973, Clinker Boatbuilding. Adlard Coles, London.
- Lehmann, L.th., 1978, The Flat-Bottomed Roman Boat from Druten, Netherlands. International Journal of Nautical Archaeology, 7.4: 259-267.
- Marsden, P., 1979, The Medieval Ships of London. In S. McGrail (Ed.), Medieval Ships and Harbours in Northwest Europe. BAR International Series, 66: 83-92, National Maritime Museum, Greenwich.

- Martin, C., 1987, North Sea Traders. In P. Throckmorton (Ed.), The Sea Remembers. London: 134-39.
- McGrail, S., 1978, Ancient Boats in N.W. Europe: The Archaeology of Water Transport to AD 1500. Longman Group UK, Essex.
- McKee, E., 1978a, Drawing the Replica. In V. Fenwick (Ed.), The Graveney Boat: A Tenth-Century Find from Kent. BAR British Series, 53: 295-302. National Maritime Museum, Greenwich.
- McKee, E., 1978b, Set of Drawings of the Parts of the Hull, and Draughtsman's Notes. In V. Fenwick (Ed.), The Graveney Boat: A Tenth-Century Find from Kent. BAR British Series, 53: 49-104. National Maritime Museum, Greenwich.
- McKee, E., 1972, Clenched Lap or Clinker. National Maritime Museum, Greenwich. London.
- Moortel, A. van de, 1987, A Cog-Like Vessel from the Netherlands. Thesis, Texas A&M University.
- Morwood, J., 1962, Sailing Aerodynamics. Adlard Coles Limited, Southampton, England.
- Nederlandsch Historisch Scheepvaart Museum, 1943, Beschrijvende Catalogus der Scheepsmodellen en Scheepsbouwkundige Teekeningen, 1600-1900. Amsterdam.

- Petrijus, E.W., 1971, Oude Zeilschepen en hun Modellen.  
De Boer Maritieme Handboeken, Unieboek N.V., Bussum.  
Second edition 1973.
- Pomey, P., 1981, L'Epave de Bon-Porté et les Bateaux  
Cousus de Méditerranée. Mariner's Mirror, 67: 225-44.
- Reinders, R., 1982, Shipwrecks of the Zuiderzee.  
Flevobericht, 197. RIJP, Lelystad.
- Reinders, R., 1985, Cog Finds from the IJsselmeerpolders.  
Flevobericht, 248. RIJP, Lelystad.
- Reinders, R., van Heen, H., Vlierman, K., Zwiers, P.B.,  
1986a, Drie Schepen uit de Late Middeleeuwen.  
Flevobericht, 166. RIJP, Lelystad.
- Reinders, R., et al, 1986b, Het Wrak van een 16e Eeuws  
Visserschip in Flevoland. Flevobericht, 140. RIJP,  
Lelystad.
- Reinders, R., (Ed.), 1987, Raakvlakken Tussen  
Scheepsarcheologie, Maritieme Geschiedenis en  
Scheepsbouwkunde. Flevobericht, 280. RIJP, Lelystad.
- Salemke, G., 1971, Die Ilmenau-Schiffe. Das Logbuch,  
1/71: 7-14.
- Steusloff, W., 1983, Das Ebersdorfer Koggenmodell von  
1400. Deutsches Schifffahrtsarchiv, 6.
- Ten Bruggencate, K., 1987, Wolter's Engels Woordenboek.  
Wolters-Noordhoff bv Groningen, The Netherlands.

- Tesch, J.J., & Veen, J. de, 1933. Die Niederlandische Seefischerei. Handbuch der Seefischerei Nordeuropas, volume 7, part 2. E. Schweizerbart'sche Verlagsbuchhandlung, Stuttgart.
- Testaguzza, O., 1970, Portus: Illustrazione Dei Porti Di Claudio E Traiano. Julia Editrice, Rome.
- Unger, R.W., 1980, The Ship in the Medieval Economy. McGill-Queen's University Press, Montreal.
- Verhoeff, J., 1983, De Oude Nederlandse Maten en Gewichten. P.J. Meertens-Instituut, Amsterdam.
- Vlierman, K. & Dijk van, L., 1980, Sintels. RIJP Werkdocument, 1980-304. Ministerie van Verkeer en Waterstaat, Rijksdienst voor de IJsselmeerpolders, Smedinghuis, Lelystad.
- Weerd, M.D. de, 1978, Ships of the Roman Period at Zwammerdam/Nigrum Pullum, Germania Inferior. CBA Research Report, 24: 15-21.
- Witsen, N., 1690, Architectura Navalis et Regimen Nauticum. Aaloude en Hedendaagsche Scheeps-Bouw en Bestier. Pieter en Joan Blaeu, Amsterdam.
- Wright, E.V., 1976, The North Ferriby Boats. Maritime Monographs and Reports, 23-1976.
- Yk, C. van, 1697, De Nederlandsche Scheeps-Bouw-Konst Open Gestelt. Amsterdam. Reprinted by Firma Langerveld, Antiquariaat-Boekhandel, Rotterdam.

Ypma, Y.N.. 1962. Geschiedenis van de Zuiderzeevisserij.

Dit proefschrift komt overeen met no. 27 van de Reeks Publicaties der Stichting voor het Bevolkingsonderzoek in de Drooggelegde Zuiderzeepolders, Amsterdam.

APPENDIX: LETTERS OF PERMISSION

ministerie van verkeer en waterstaat

rijksdienst voor de ijsmeerpolders

Mr. Ralph K. Pedersen  
84 Barrister Road  
Levittown, NY 11756  
USA

uw brief van: October 17, 1987

lelystad, January 20th 1988

03200-

uw kenmerk:

ons kenmerk: Cbw 1495

toestelnummer: 7177

onderwerp: Master Thesis

bijlage(n):

verzonden: - 2 FEB. 1988

Dear Mr. Pedersen,

I hereby give you permission to study the documentation on two shipwrecks, excavated on lots NZ 42 and NZ 44, for your Master thesis at Texas A & M University.

Concerning the research by A & M students of old Zuiderzee excavations, not published before, we make the following conditions:

- permission of the RIJP is necessary for the publication of reports, articles etc.;
- in the case of publication, the thesis or part of it will be published first in the series "Flevoberichten" or will be used for such a publication after consult between RIJP and A & M.

If you like to have additional information, please contact Mr. R. Reinders. I wish you success with your investigation.

Sincerely yours,

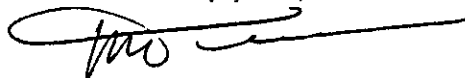

Ir. K.S. Feitsma



postbus 600  
8200 AP lelystad The Netherlands  
smedinghuis  
zuidewagenplein  
tel. (03200) 99111  
telex 40115

bankrekening: amrobank nv lelystad rekening 45.90.72.005  
postrekening 869847

bereikbaar met de buslijnen  
107, 143, 150, 154, 157 en 159  
(halte noorderwaggenplein)

# Rijksmuseum-Stichting

Afdeling Verkoop  
 Hobbemastraat 21  
 1071 XZ Amsterdam  
 Tel. 020-73 21 21 tst. 225-350  
 Postgiro 24 72 07  
 Bank: Algemene Bank Nederland  
 54.20.19.086

Texas A&M University  
 Ralph K. Pedersen  
 Nautical Archaeology Program  
 College Station, TX 77840  
 USA



## Rekening/Invoice

No.	V-10117	Datum Uw order	February 8, 1991	
1	print 13 x 18 cm p&p bankcosts cheque handling	fl.	8.—	
			3.50	
			10.—	
			5.—	
		fl.	<u>26.50</u>	
the photograph of a print depicting a "waterschip" will be sent to you as soon as payment has been received				
we give permission to use this print in your thesis				
(130)				

Onze winst komt geheel ten goede aan het Rijksmuseum te Amsterdam voor aankoop van kunstwerken. The whole of our profit is spent on works of art for the Rijksmuseum at Amsterdam.

Please mention invoice number at payment. Bij betaling factuurnummer vermelden s.v.p.

Goederen zijn/worden verzonden voor risico van koper. Goods have been/will be sent at buyer's risk.

18 December 1990

Ralph K. Pedersen  
Nautical Archaeology Program  
Texas A&M University  
College Station, TX 77840  
U.S.A.

Unieboek B.V.  
Onderdoor 7  
Postbus 97  
3990 DB Houten  
The Netherlands

Dear Sir,

I am a Master's Degree candidate at Texas A&M University currently completing my thesis concerning the reconstruction and analysis of a wreck from the polderlands known as "Waterschip NZ421." I am preparing this study with the permission of the Rijksdienst voor IJsselmeerpolders (RIJP) and the Museum voor Scheepsarcheologie at Ketelhaven. I also intend to publish my work in Flevobericht, the publication of the RIJP.

I therefore request permission to use in my thesis and eventual publication, a photocopy of the drawing of a waterschip as it appears in Oude Zeilschepen en hun Modellen, by E.W. Petrejus, 1973, page 117.  
Thank You.

Sincerely,

  
Ralph K. Pedersen

*permission granted.*  
Unieboek B.V.  
Onderdoor 7  
Postbus 97  
3990 DB Houten  
Tel.no.: 03403-77660

30.12.90



**ANTWERPEN 1993**  
culturele hoofdstad  
van EUROPA

**ANVERS 1993**  
capitale culturelle  
de l'EUROPE

**ANTWERPEN 1993**  
Kulturhauptstadt  
EUROPAS

**ANTWERP 1993**  
cultural capital  
of EUROPE

**AMBERES 1993**  
capital cultural  
de EUROPA

**ANVERSA 1993**  
capitale EUROPEA  
della cultura

**ANTUERPIA 1993**  
capital cultural  
da EUROPA

**ANTWERPEN 1993**  
kultur hovedstad  
I EUROPA

**ΑΜΒΕΡΣΙΑ**  
κρητοσοσια της ΕΥΡΩΠΗΣ στη  
τηλεοπτική και ακουστική

**АНТВЕРПЕН**  
культурная столица  
ЕВРОПЫ

**אנטוורפן**  
עיר בירה תרבותית  
באירופה

**أنتويرب**  
عاصمة ثقافية  
لأوروبا

アントワープ一九九三年  
ヨーロッパの文化の首都です

安特衛普市一九九三年  
歐洲文化中心

Onder de Hooge Bescherming  
van Hunne Majesteiten  
Koning Boudewijn en  
Koningin Fabiola.

Sous le Haut Patronage de  
Leurs Majestés le Roi  
Baudouin et la Reine  
Fabiola.

Unter der Schirmherrschaft  
Seiner Majestät König  
Balduin und Ihrer Majestät  
Fabiola.

Under the High Patronage of  
Their Majesties King  
Baudouin and Queen  
Fabiola.

Mr. Ralph K. Pedersen  
Nautical Archaeology Program  
Texas A&M University  
College Station TX 77840  
U.S.A.

OM/NSM

Uw brief d.d.:

Uw nummer:

Ons nummer (te vermelden bij antwoorden):

Datum:

NSM 1 910123/RJ

23/01/1991

Onderwerp:

Bijlagen:

Dear Sir,

Answering to your letter we communicate that you are free to use in your thesis a photograph of the etching by R. Nooms "Een waterschip of Zuyderzeese Visser".

If you want to publish your study in "Flevobericht", a review that is for sale on the market, than you need the permission of the Antwerp City Administration wich will send you a separate invoice for copyrights.

Please let us know what you are planning to do. Meanwhile you can order the photo by transferring 210,-BF + 200,-Bf bankcosts into bankaccount 409-9522031-70 (Kredietbank), on name of the "Friends of the National Maritime Museum", Steenplein 1 - B-2000 Antwerp. After receipt of your payment the photo will be send to you as soon as possible.

Yours truly,

A. De Vos,  
Curator

Gerhard Salemke  
Austernbreite 16  
4830 Gütersloh 1

den 12.2.91

Herrn  
Arvid Göttlicher  
Spitzwegstr.3  
Bremervörde

Ich habe keine Einwände gegen die Verwendung der Zeichnungen vom Ilmenau-Ever, Logbuch 1/71 S.10+12 für Herrn Pedersen in Texas.

*Gerhard Salemke*

13. Feb. 1991

16/2/91

Dear Mr. Pedersen,  
in the meantime I got Mr. Salemke's answer.  
You may reproduce his drawings as much  
as you like!

I wish you all your best for finishing  
your thesis and hope we get a copy  
for review!

*Yours sincerely*

Bundeswehr - Besucherservice/1

*Möhlhede*

Wolfgang Steusloff  
Alte Warnemünder Chaussee 25  
O - 2520 Rostock 27  
Germany

15 February 1991

Dear Sir,

answering your letter from 18th of december 1990 (posted on january 11th, arrived only 1½ weeks ago) I have the pleasure to give you full permission to use the mentioned illustrations from my article "Das Ebersdorfer Koggenmodell von 1400" in "Deutsches Schifffahrtsarchiv" 6/1983.

I hope you will get my reply in good time, and I want to wish you well success for your thesis and your eventually publication.

You took into consideration, that my address could have changed meanwhile. So it is, but from this can not arise any problems of contact, because the older one is the actually address of my parents, near by.

Sincerly,

  
Wolfgang Steusloff

*Vereeniging*  
*Nederlandsch Historisch Scheepvaart Museum*  
*Beschermvrouwe: H. M. de Koningin*

---

To:

Ralph K. Pedersen,  
 Nautical Archaeology Program,  
 Texas A&M University  
 College Station, TX 77840  
 U.S.A.

Amsterdam, 29 januari 1991.

PRO FORMA INVOICE NR.:

You have permission for one-time use only in your	Dfl.
book to reproduce the illustration:	-
Lithograph by P. le Comte depicting waterscheepen	-
towing a ship set in scheepkamelen	-
Please send us a copy of the publication	-
because the museum conditions for publishers	-
are one copy of the publication.	-
..... Thank you	-
..... Sincerely,	-
..... X. Roggaut.	-
Postal and handling charges.....	- _____
Total.....	Dfl =====

Unless specifically stated, the above mentioned amount do not include reproduction rights.  
 After receipt of your payment the goods will be sent to you as soon as possible.  
 When paying please refer to the invoicenummer mentioned above.

The due amount can be paid:

- by using an International Money Order or
- per giral account ( our acc.nr.: 146794 - Ver.Ned. Hist.Scheepvaart or  
 Museum, Amsterdam Netherlands)
- to Bank Mees & Hope, PO Box 293, 1000 AG Amsterdam Netherlands or  
 account number: 21.37.10.617

*p/a 's Lands Kasemagarijn, Kalloerhingerplein, 1018 H H Amsterdam. Tel. 020- 5232217*  
*Post giro 146794*

Permission has been requested for the use of the depiction by B. Florisz.

## VITA

Ralph Kenneth Pedersen

Permanent Address:

84 Barrister Road, Levittown, New York 11756 U.S.A.

Education:

1984-1991: Master's candidate in Anthropology- Nautical Archaeology program, Texas A&M University.

1984: Bachelor of Art in Anthropology with a minor in Linguistics. State University of New York at Stonybrook, Long Island, New York.

1979: High School Regents Diploma, Island Trees High School, Levittown, Long Island, New York.

Professional Experience:

1991: Named to the Board of Directors of the Pan-American Institute of Maritime Archaeology (PIMA).

1990: Named excavation director/director of photography for PIMA's 1991 Monte Cristi Pipewreck Excavation near Monte Cristi, The Dominican Republic.

1989: Excavation of the Ulu Burun Bronze Age shipwreck near Kas, Turkey. Team member. Project of the Institute of Nautical Archaeology (INA).

1988: Excavation of the Ulu Burun Bronze Age shipwreck near Kas, Turkey. Team member. Project of INA.

1986: Excavation of the Ulu Burun Bronze Age shipwreck near Kas, Turkey. Team member. Project of INA.

1985: Excavation of the Ulu Burun Bronze Age shipwreck near Kas, Turkey. Team member (surface crew). Project of INA.

Other Experience:

1973-1989: Carpenter. Current status: Journeyman.  
Birger Pedersen Construction, Incorporated. Levittown,  
Long Island, New York.