

Rigging of Period Ship Models
PETERSSON

Rigging

PERIOD SHIP MODELS



LENNARTH
PETERSSON

aval
itute
ess

Rigging

PERIOD SHIP MODELS

*A Step-by-Step Guide to the
Intricacies of Square-Rig*

THE rigging of period ship models is arguably the most complex task which any modeller has to take on. The very scale of the work is daunting. An eighteenth-century man-of-war boasted mile upon mile of rigging, over 1,000 blocks and acres of canvas. To reduce this in scale and yet retain an accurate representation is, indeed, an awesome undertaking.

This remarkable book of drawings, however, makes the modeller's job logical and straightforward. The author has drawn over two-hundred detailed diagrams which show clearly how each separate item of both standing and running rigging is fitted to the masts, yards and sails; belaying plans are included and knots and fastenings are also depicted. Based on the model of the frigate *Melampus*, this rigging plan is the most detailed available in any publication. Whether a modelmaker needs to rig a whole ship or just requires information on one aspect, it is all here.

NAVAL INSTITUTE PRESS

ISBN 1-55750-970-0



90000

9 781557 509703



Rigging Period Ship Models

*A Step-by-Step Guide
to the Intricacies
of Square-Rig*

Lennarth Petersson

NAVAL INSTITUTE PRESS
Annapolis, Maryland

Acknowledgements

It is my intention to limit this book to the classification of the rigging of *Melampus* and no mention is made of the numerous alternative aspects of square rig to be found during the eighteenth century; this work describes the rigging of a specific period and one specific model. I hope the perspective drawings will help towards an understanding of the use of standing and running rigging for modellers and for all with an interest in square rig.

I would like to thank Captain Olof Pipping; my good friend Vernon Gidman; Mr Alan King, curator of the Bristol Industrial Museum; my family and parents for patience and support; and Julian Mannering, editor of Chatham Publishing, for help and advice. Beyond that, I take all the blame.

Copyright © Lennarth Petersson 2000

All rights reserved. No part of this book may be reproduced without written permission of the publishers.

First published in Great Britain by Chatham Publishing,
61 Frith Street, London W1V 5TA

Published and distributed in the United States of America and Canada by the Naval
Institute Press, Beach Hall, 291 Wood Road, Annapolis, Maryland 21402-5034

Library of Congress Catalog Card No. 00-104383

ISBN 1-55750-970-0

This edition is authorized for sale only in the United States, its territories and possessions, and Canada.

Manufactured in Great Britain.

Contents

<i>Introduction</i>	1	Mizzen Topsail Sheet & Clueline	56
Fore Channels & Dead-Eyes	2	Mizzen Topgallant Sheet & Clueline, Mizzen Royal	
Main Channels & Ratlines	3	Sheet	57
Mizzen Channels	4	Jibboom & Flying Jibboom Guys	58
Fore Shrouds	5	Spritsail Sling, Spritsail Yard & Spritsail Topsail Yard	
Main & Mizzen Shrouds	6	Halliards	59
Fore Topmast Shrouds	7	Royal Stay	60
Mizzen Backstays	8	Fore Topgallant Stay & Bumpkin Shrouds	61
Main Backstays	9	Jib Outhaul	62
Fore Backstays & Shrouds	10	Flying Jib Outhaul	63
Fore Backstay, Topmast & Topgallant Shrouds	11	Spritsail Lift, Spritsail Topsail Clueline & Sheet	64
Stays (overall view)	12	Spritsail Clueline & Sheet Spritsail Topsail Lift	65
Mizzen Stay	13	Fore Topsail Reef Tackle	66
Main Stay & Preventer Stay	14	Main Topsail Reef Tackle	67
Fore Stay & Preventer Stay	15	Mizzen Topsail Reef Tackle	68
Mizzen Topmast Stay & Topgallant Stay	16	Spritsail Buntlines	69
Main Topmast Stay, Preventer Stay, Topgallant		Fore Course Buntlines & Leechlines	70
and Royal Stay	17	Fore Topsail Buntlines	71
Fore Topmast & Preventer Stay	18	Main Course Buntlines & Leechlines	72
Jibstay, Fore Topgallant, Flying Jib & Royal Stay	19	Main Topsail Buntlines	73
Bobstay, Bowsprit Shrouds	20	Mizzen Topsail Buntlines	74
Jibstay & Martingale Stays	21	Fore Course & Topsail Bowlines	75
Cross Jack Truss Pendant	22	Fore Topgallant Bowlines	76
Cross Jack Sling	23	Main Course & Topsail Bowlines	77
Cross Jack Lift	24	Main Topgallant Bowlines	78
Spanker Boom Sheet & Guy Pendants	25	Mizzen Topsail & Topgallant Bowlines	79
Boom Topping Lift	26	Mizzen Mast Square Sails	80
Vangs	27	Spanker	81
Peak Halliard	28	Mainmast Square Sails	82
Throat Halliard	29	Fore Mast Square Sails	83
Mizzen Tyes: Topsail, Topgallant & Royal Yard	30	Yard Tackle & Tricing Lines	84
Mizzen Lifts: Topsail & Topgallant	31	Yards	85
Cross Jack Braces	32	Main Yard with Stunsail Boom & Stunsail Boom Irons	86
Mizzen Topsail & Topgallant Braces	33	Fore Staysail	87
Fore & Main Sling	34	Main Staysail	88
Fore & Main Jeers	35	Mizzen Staysail	89
Truss Pendants & Nave Line	36	Fore Topmast Staysail Stay	90
Main Lift	37	Fore Topmast Staysail	91
Fore Lift	38	Fore Topmast Staysail	92
Main Topsail Yard Tye & Halliard	39	Main Topmast Staysail	93
Fore Topsail Yard Tye & Halliard	40	Mizzen Topmast Staysail	94
Fore Topgallant/Royal Tye & Halliard	41	Main Topgallant Staysail	95
Fore Topsail, Topgallant & Royal Lifts	42	Jib	96
Main & Main Topsail Braces	43	Flying Jib	97
Fore & Fore Topsail Braces	44	Belaying plans	98
Fore & Main Topgallant Braces	45	Cross-section	102
Fore & Main Royal Braces	46	External Hull	104
Spritsail & Spritsail Topsail Braces	47	Square Sails	106
Fore Sheet, Tack & Clueline	48	All Fore and Aft Sails	107
Fore Topsail Sheet & Clueline	49	Studding Sails	108
Fore Topgallant & Royal Sheet, Fore Topgallant		Quarter Deck	111
Clueline	50	The Bow	112
Main Sheet, Clueline & Tack	51	The Stern	113
Main Topsail Sheet	52	Waist & Forecastle	114
Main Topsail Lift (Topgallant & Royal Lifts)	53	Index	116
Main Topsail Clueline	54		
Main Topgallant Sheet & Clueline, Main Royal Sheet	55		

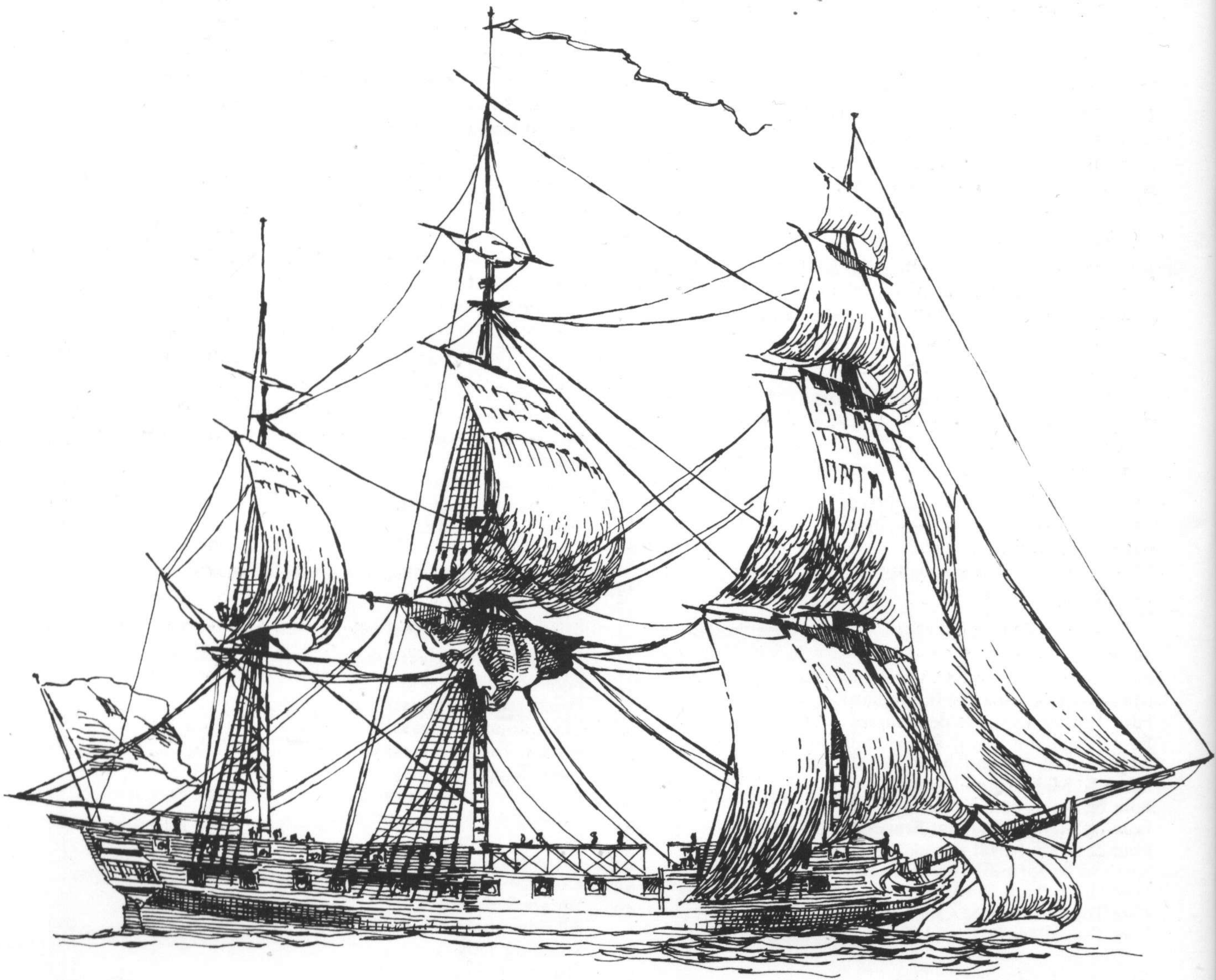

Introduction

I SET OUT TO CREATE this series of detailed drawings because, as a modelmaker, I needed the answers to a number of questions relating to the intricacies of square rig. I could find no publication which allowed me to study a ship's rigging in the way that one can, for example, in front of a model in a museum. And even then, of course, the sheer complexity is confusing and difficult to grasp. Most modelling books, while dealing extensively with hull construction, often approach rigging in a rather cursory fashion. The genesis of this book was, therefore, the desire to fill that gap. I decided to study and depict each item of a ship's rigging on its own, isolated on a page, so that the reader might understand where a particular sheet or halliard, for example, leads and how it functions.

One of the pleasures of researching and putting together all these drawings was the realisation of how logical and functional the rigging of a square-rigged ship is. This really should not have come as a surprise. Sailors are nothing if not practical, and the apparently complicated confection of ropes and tackles is, in fact, a wonderfully simple and ordered creation with no unnecessary or redundant parts. My intention in the book is to show this simplicity and, at the same time, draw to the reader's attention the basic principles by which square-rig functions; throughout the centuries, square-rigged ships have followed the same principles when it has come to catching the wind.

Though these principles have remained the same I felt it important, both for the sake of accuracy and for the benefit of modellers, to draw from a contemporary model, and I decided on an English frigate which should have retained most of its original rigging. By going to a three-dimensional source I hoped to be able to depict the intricate details in the clearest possible manner, and by choosing a contemporary model create a scheme which was authentic. With the help of the publisher I found a suitable model, with much of its original rigging intact, in the Bristol Industrial Museum. It is a beautiful model of the *Melampus*, a 36-gun, 18-pounder frigate. It was donated to the museum in 1844 and while it has received the attention of restorers over the years its rigging is considered a reliable representation. I photographed and sketched the model from every angle and the results of the exercise were the source for the drawings in this book.

Melampus seemed a suitable choice not just because of her authenticity but also because of her relatively small size and her long and quite distinguished career. All modelmakers, I'm sure, feel happier working on the model of a prototype which

distinguished herself and *Melampus* had a long career during one of the most turbulent periods of the Royal Navy's history.

She is one of four models of ships which were built by the Bristol yard of James Martin Hillhouse and is assumed to have been commissioned by the builders. The ship herself was launched in 1785 and was one of the biggest frigates of her day. She was one of the first of a new generation of 18-pounder frigates and carried 36 guns rather than the 38 of similarly sized vessels and, subsequently, had more space on her gundeck and performed well at sea. Her reputation spread soon enough and she was coveted as a command by, among others, Prince William Henry – later William IV

During her thirty years of service in the Royal Navy she took part in a number of actions. In 1794, for instance, she was with the *Arethusa* and two other frigates in Warren's action against Desgarceaux's squadron, which ended in the capture of three French frigates. Under the command of Sir Richard Strachan, *Melampus*, along with four other frigates, chased a French convoy into Carteret Bay where every ship bar one was destroyed by the ships' boats. Three years later, in 1798, under the command of Captain Moore, she was involved in the interception of the Brest fleet off Ireland and captured the *Bellone*, a 44-gun frigate. Two days later she took another frigate, the *Resolute* 36. She was later, in 1807, to experience the fall-out of the *Leopard-Chesapeake* action when two-hundred of her water-casks were burnt by the enraged inhabitants of Norfolk, Virginia. In 1811 she captured the slaver *Fortune* and brought her back to Plymouth, and, finally, in 1815, she was sold off to the Dutch navy. Despite being thirty years old, she continued to serve for another decade.

I hope this book will make the task of rigging easier for modelmakers at all levels. Certainly, researching and drawing out the illustrations answered a lot of questions for me. There are other works which any modelmaker needs to refer to and which have been stalwart guides for me. Foremost are James Lee's *The Masting and Rigging of English Ships of War 1625-1860*, and C N Longridge's *The Anatomy of Nelson's Ships*. Any modeller's book shelf also requires *The Ashley Book of Knots*.

Finally, the journal *Seaways* and *The Nautical Research Journal*, from Nautical Research Guild in the US, have been useful guides for me.

LENNARTH PETERSSON
Habo, Sweden, 2000

Fore Channels & Dead-Eyes

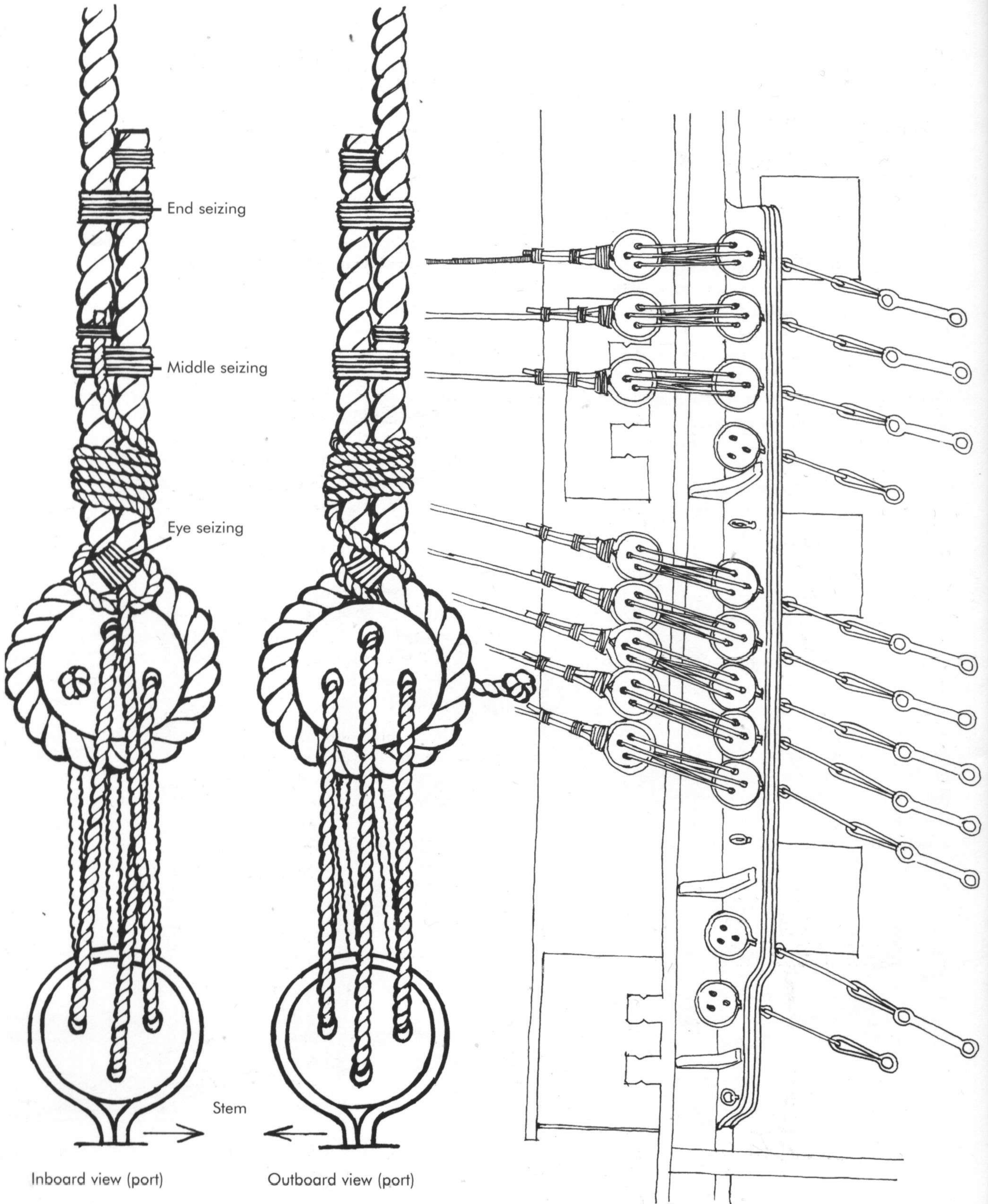

Main Channels & Ratlines

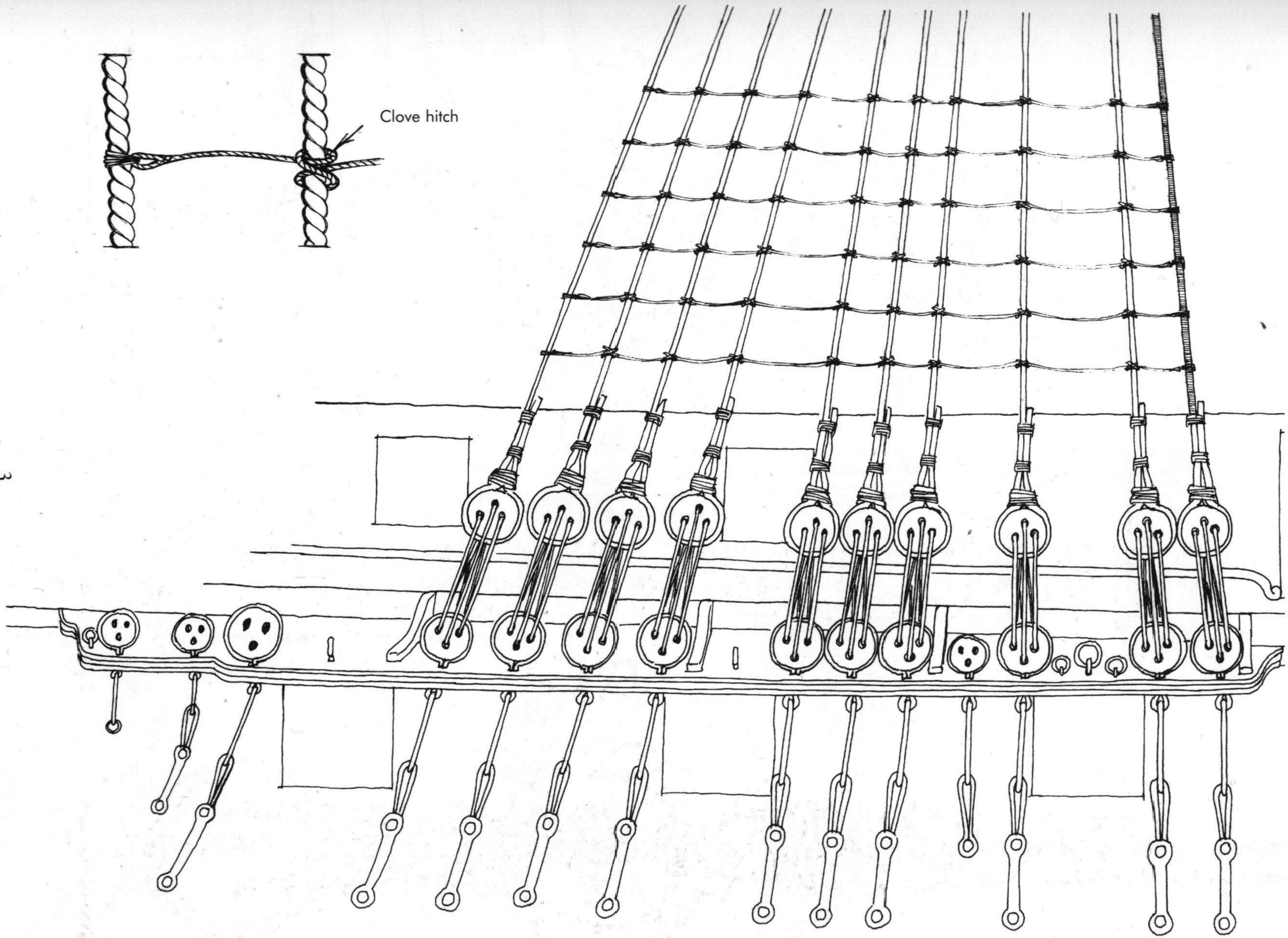

Mizzen Channels

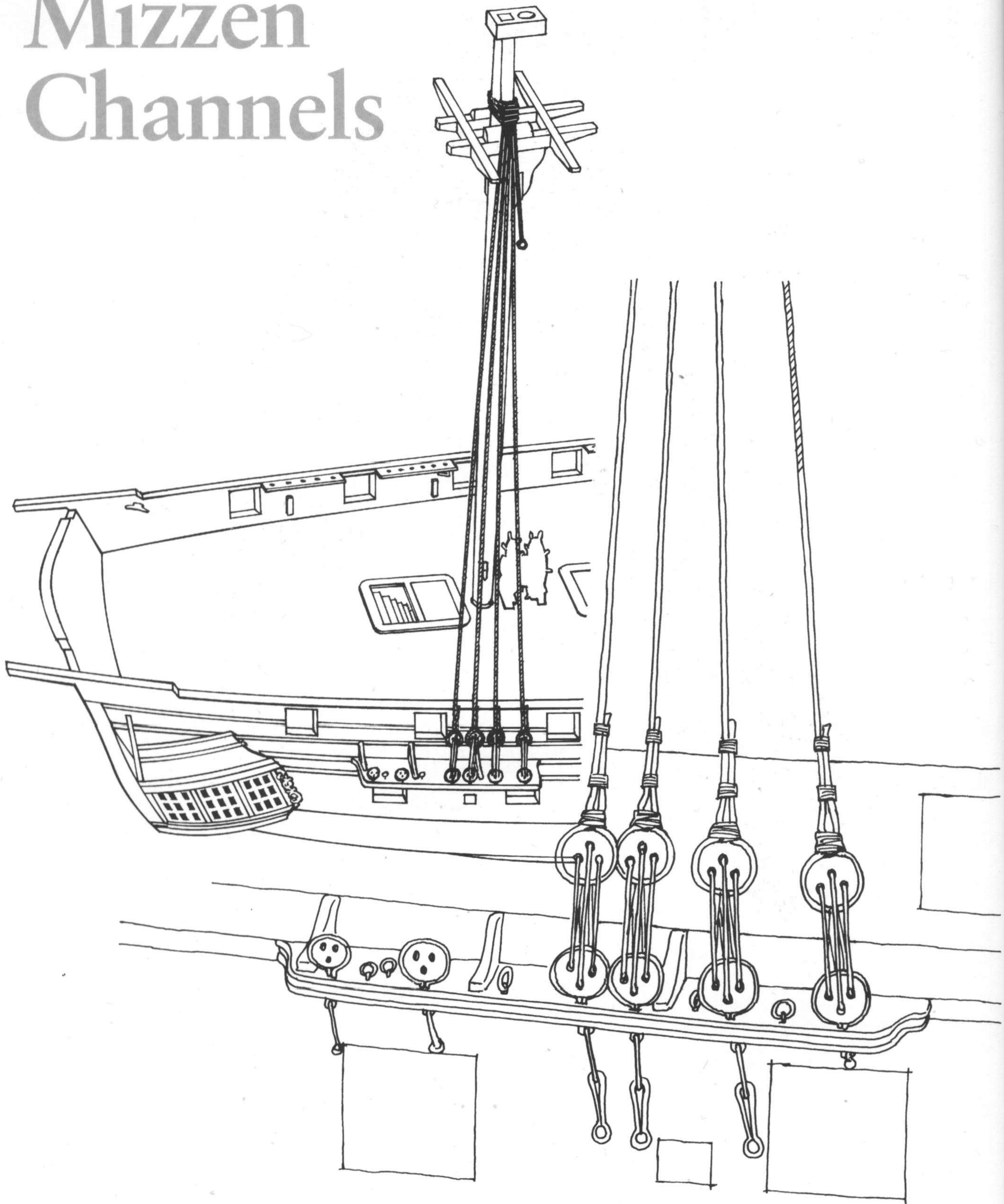

Fore Shrouds

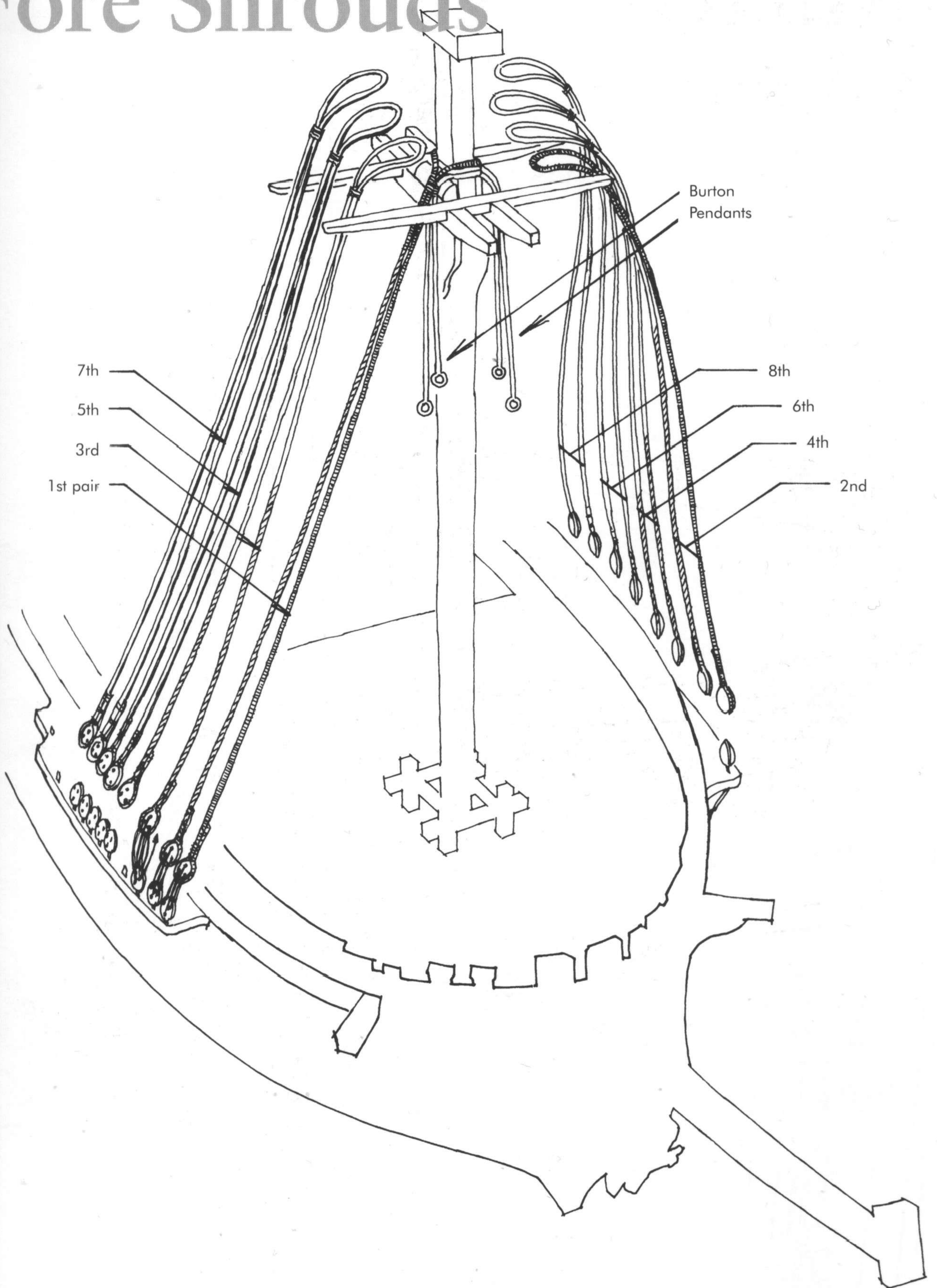

Main & Mizzen Shrouds

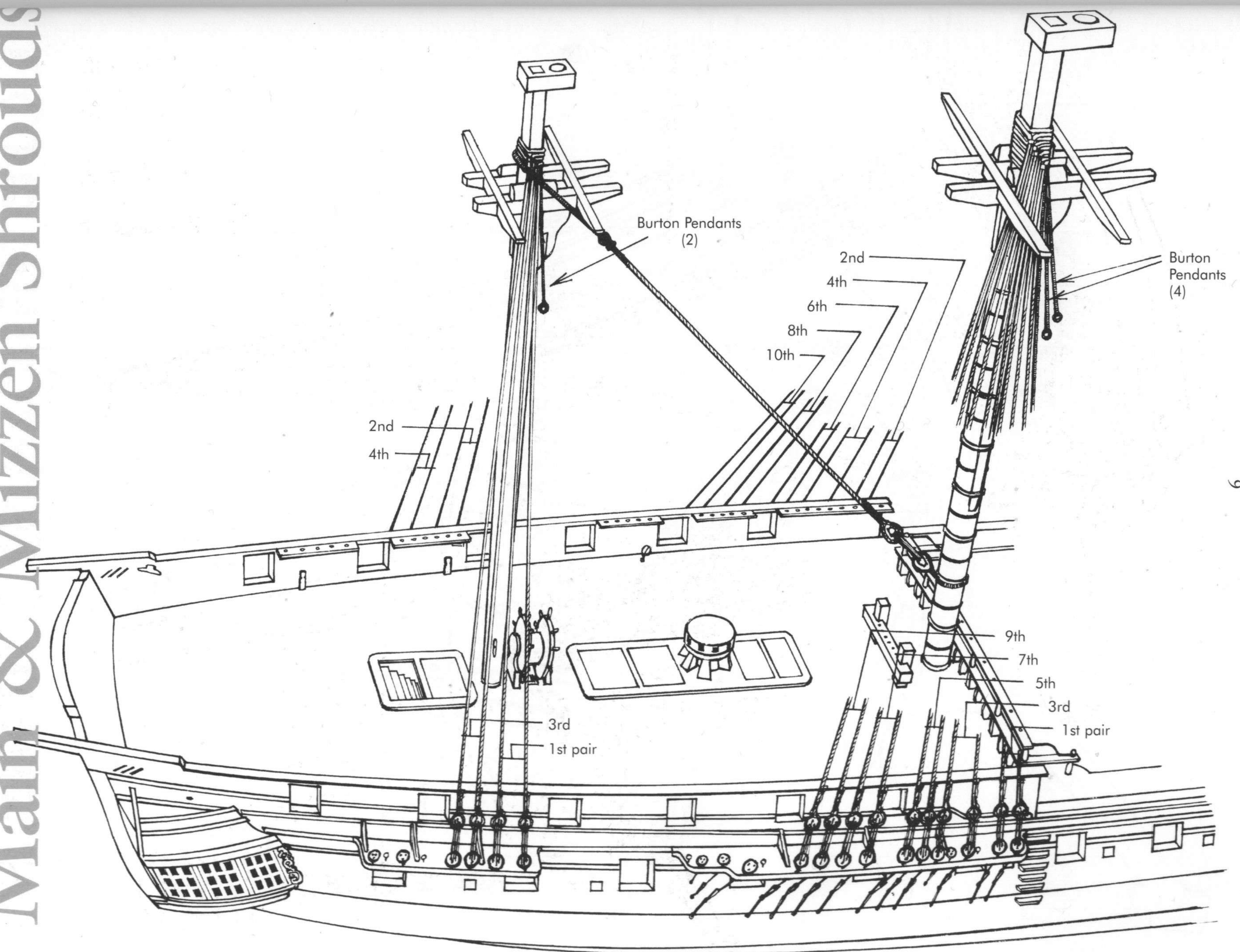

Fore Topmast Shrouds

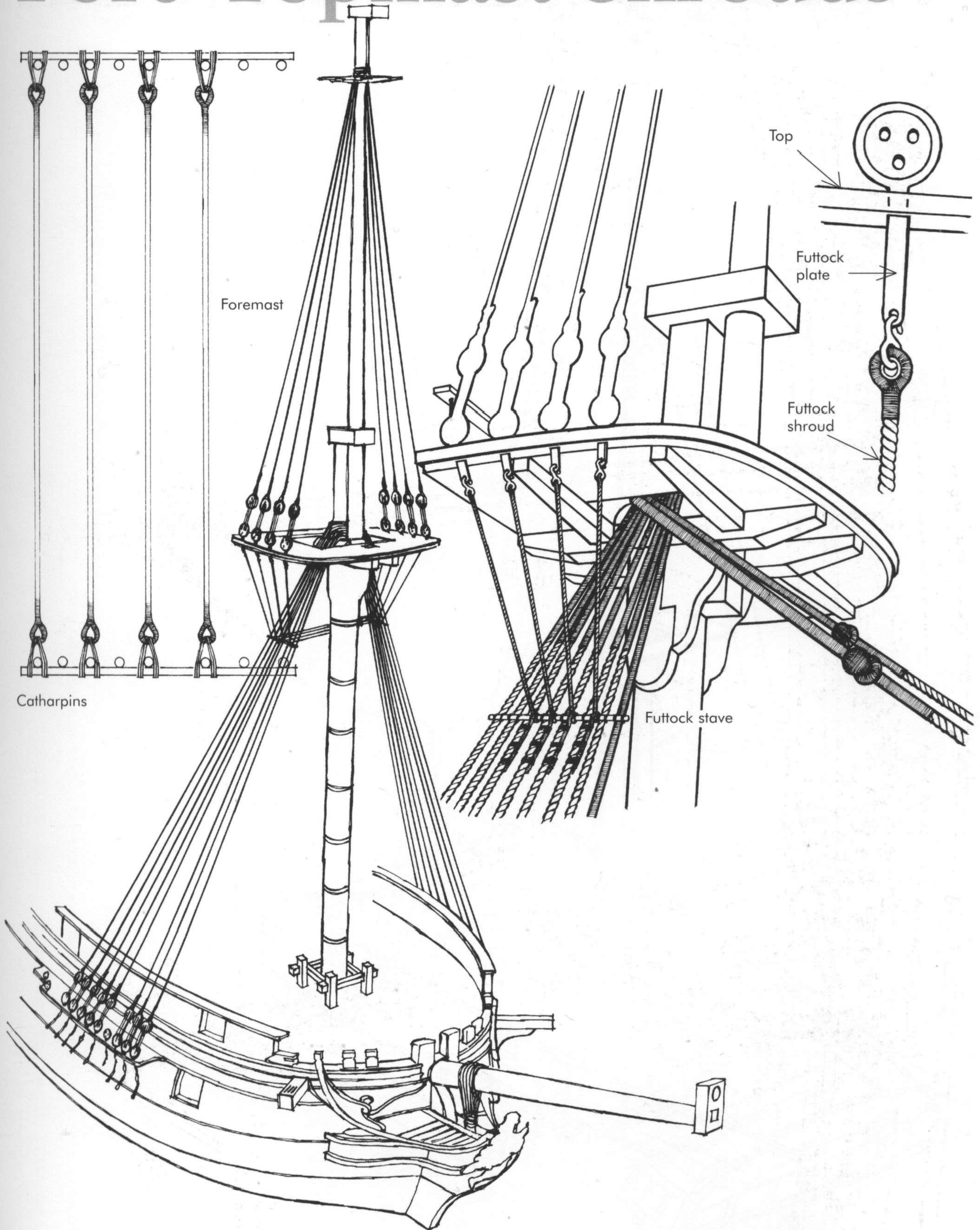

Mizzen Backstays

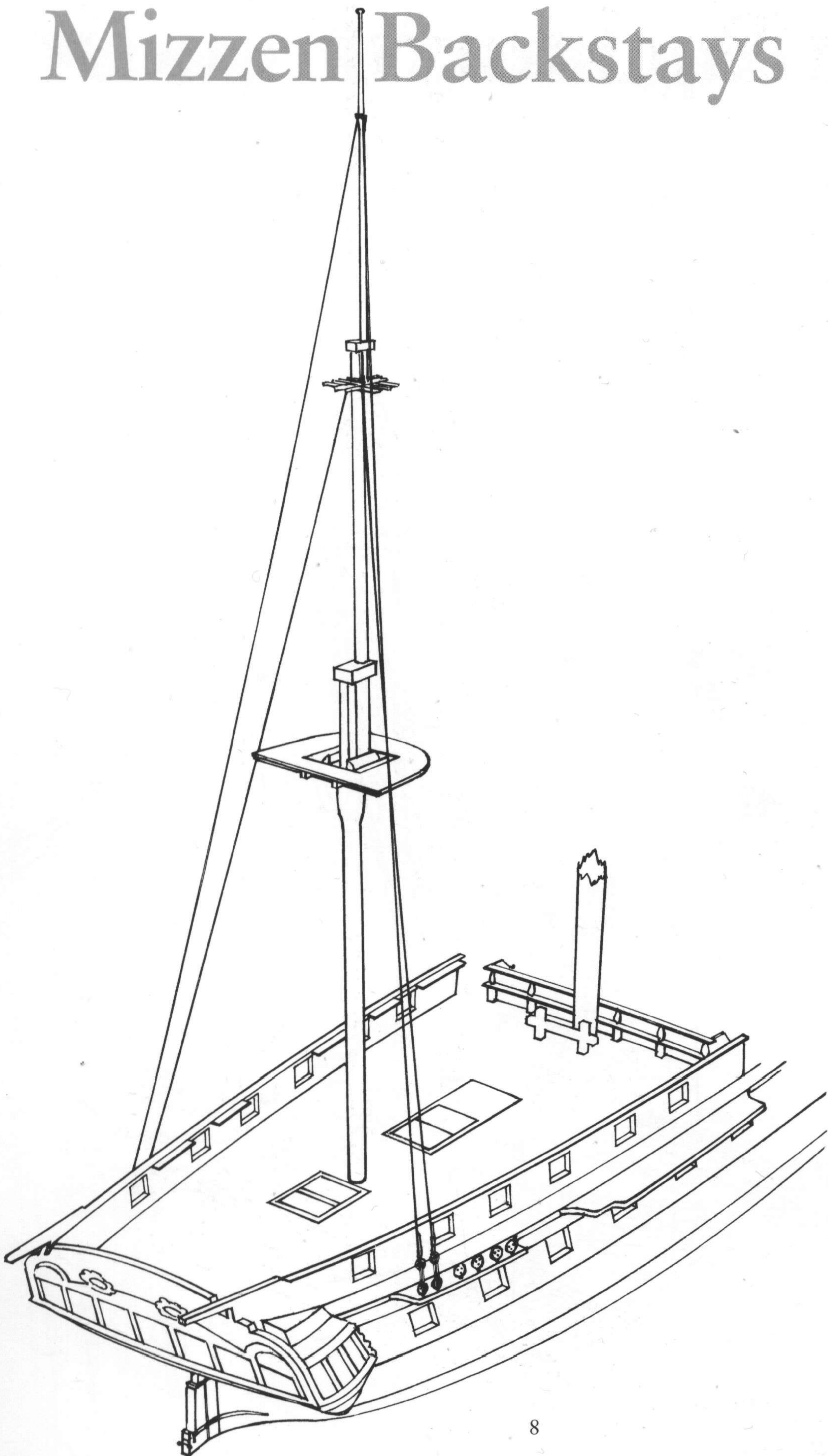

Main Backstays

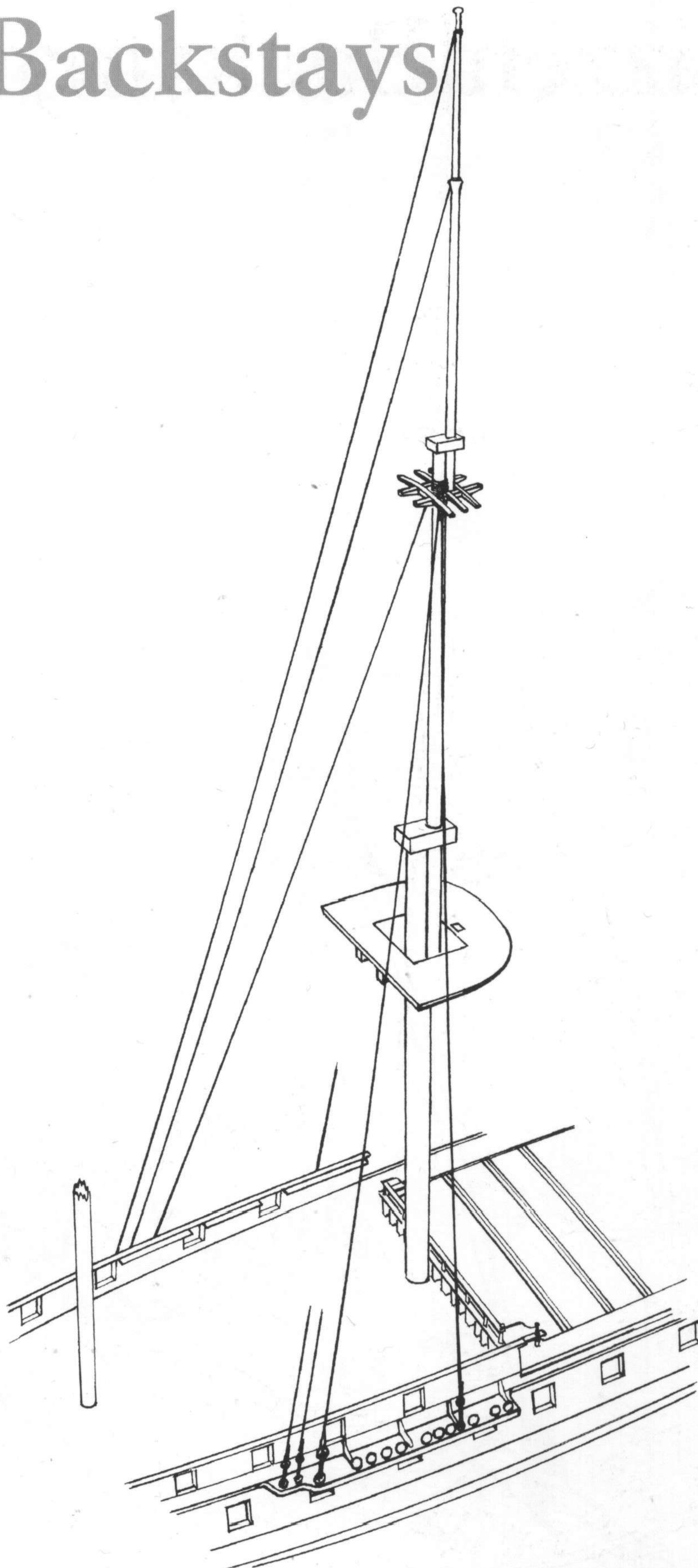

Fore Backstays & Shrouds

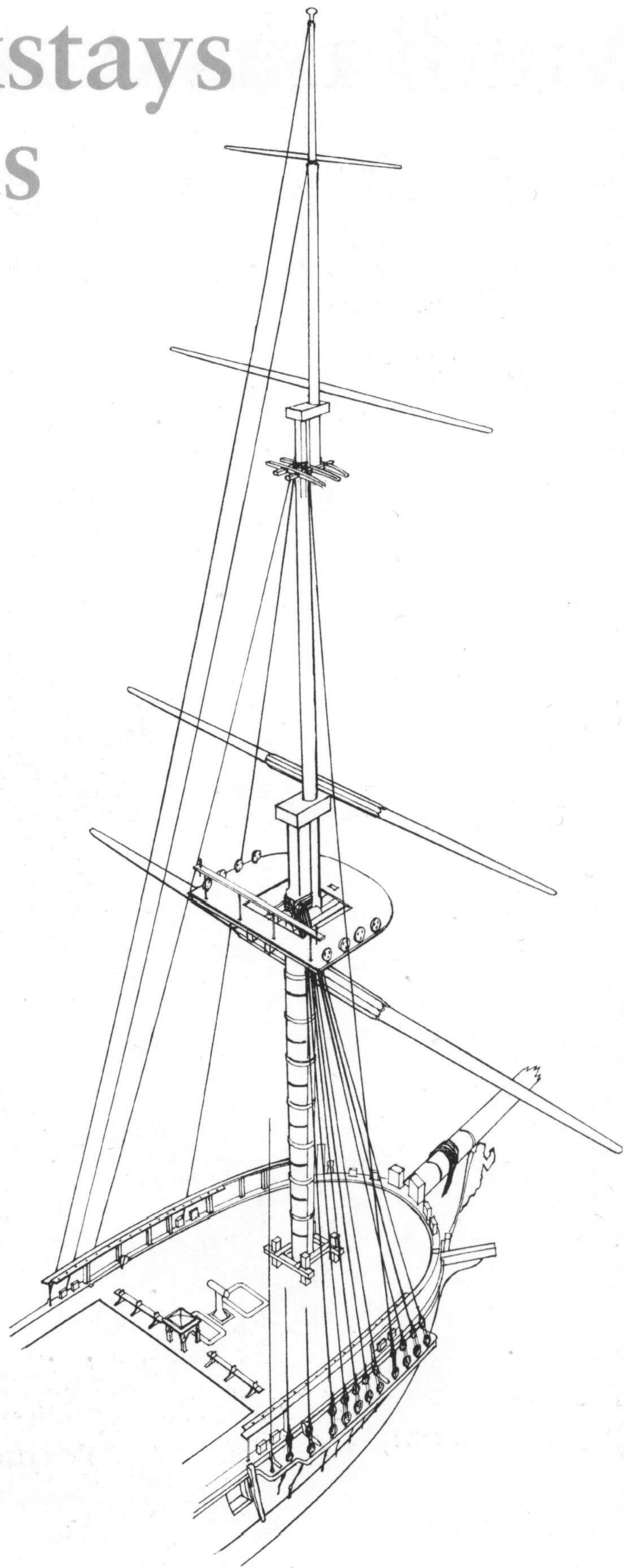

Fore Backstay, Topmast & Topgallant Shrouds

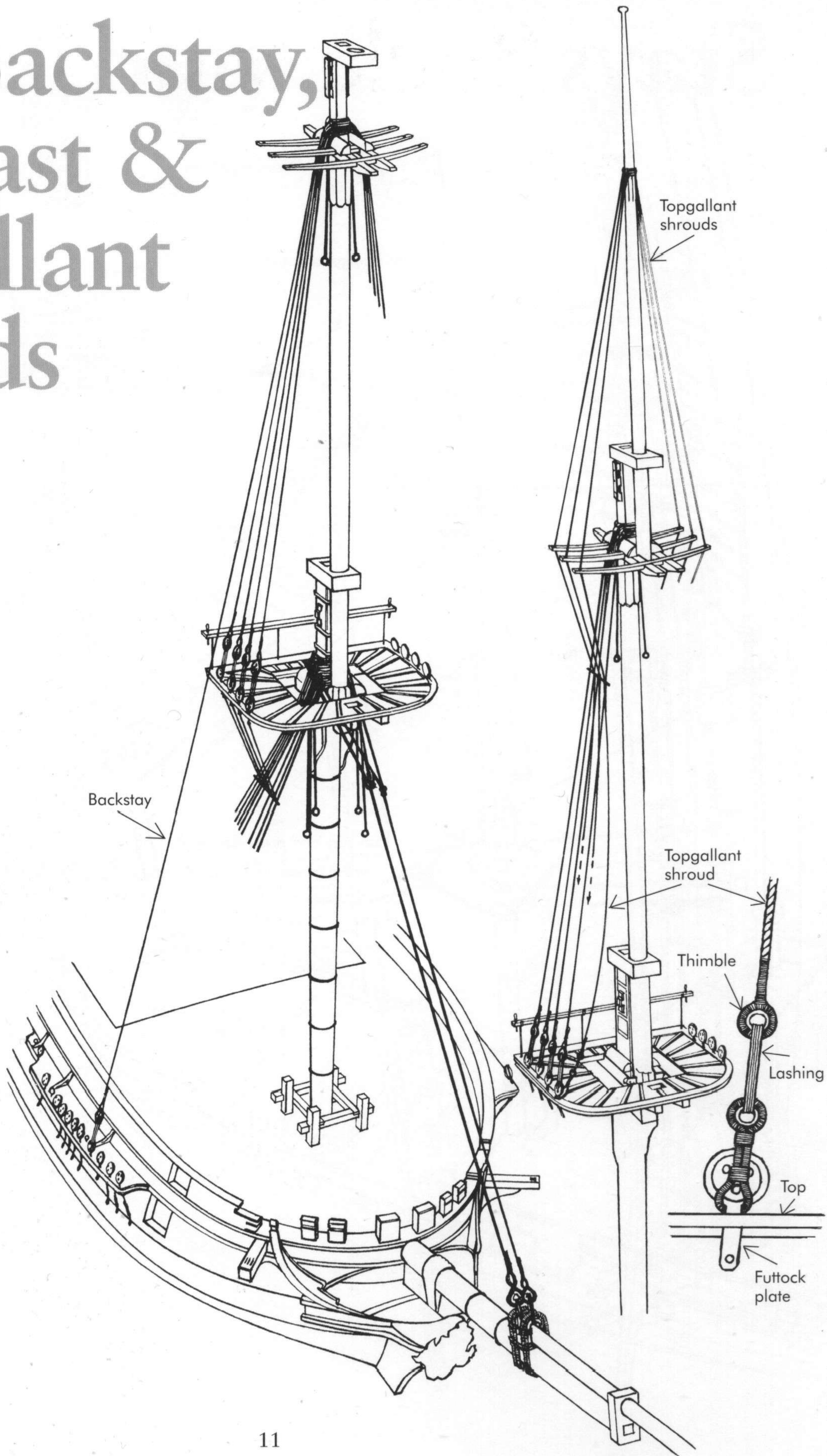

Stays

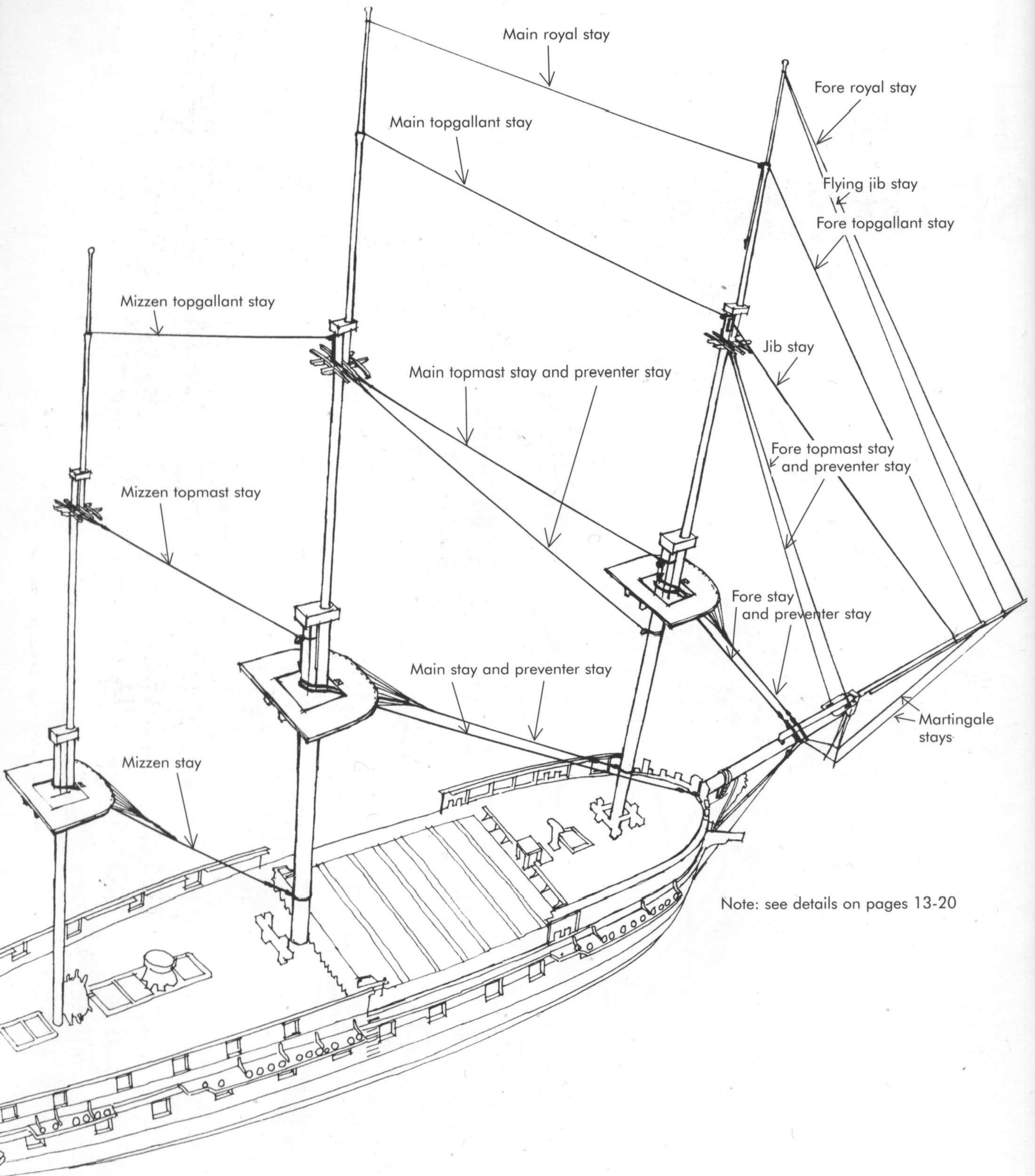

Mizzen Stay

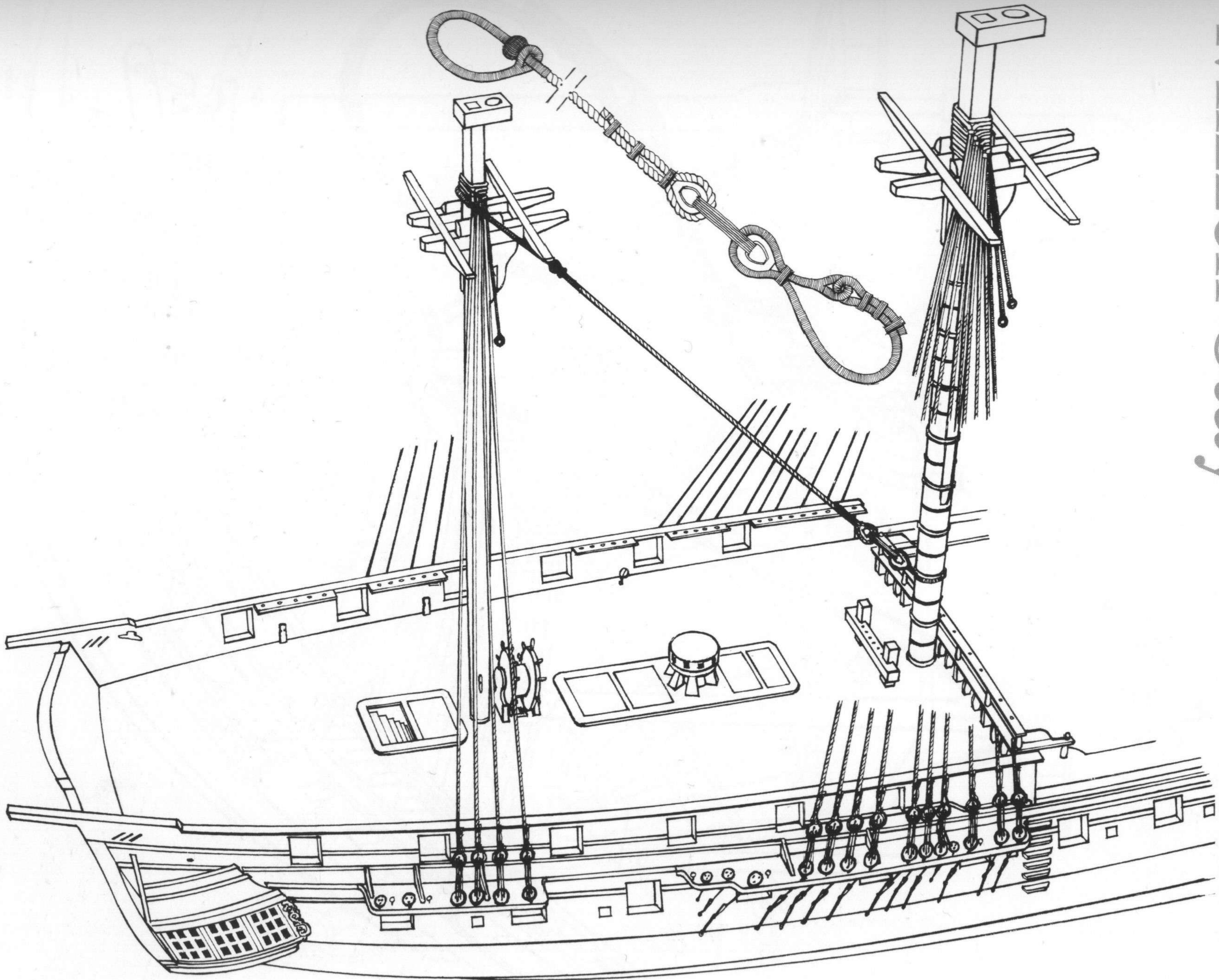

Main Stay & Preventer Stay

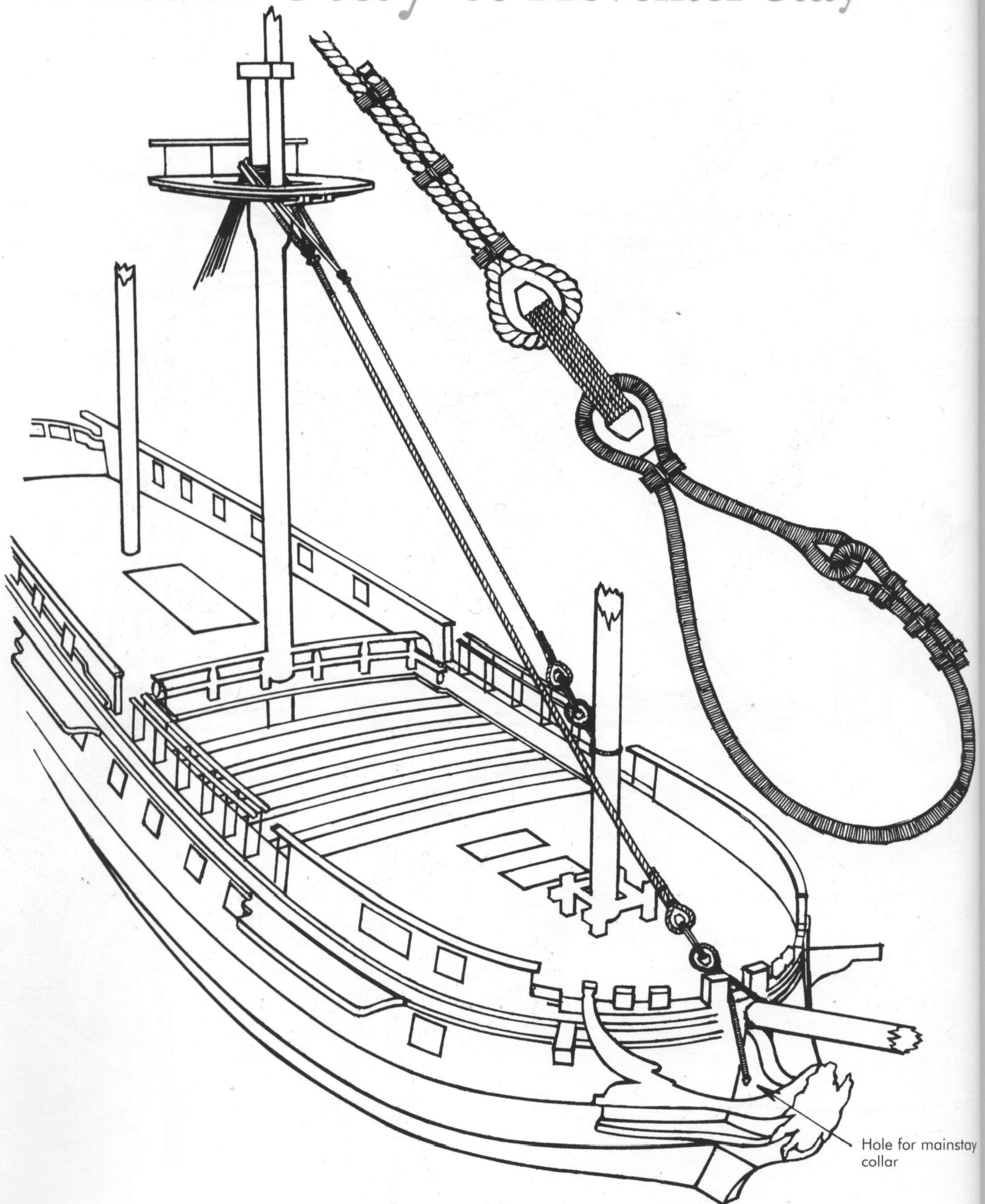

Fore Stay & Preventer Stay

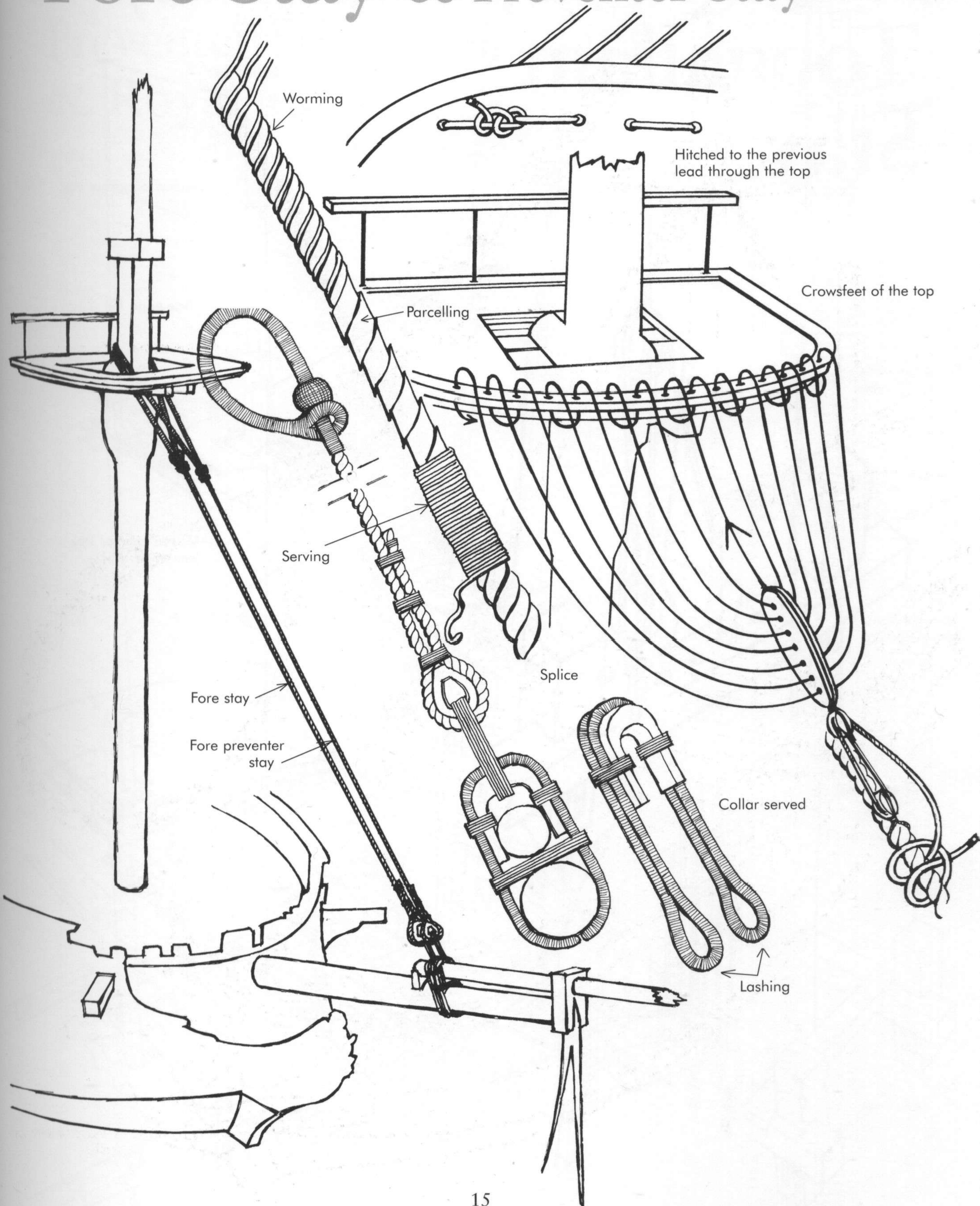

Mizzen Topmast Stay & Topgallant Stay

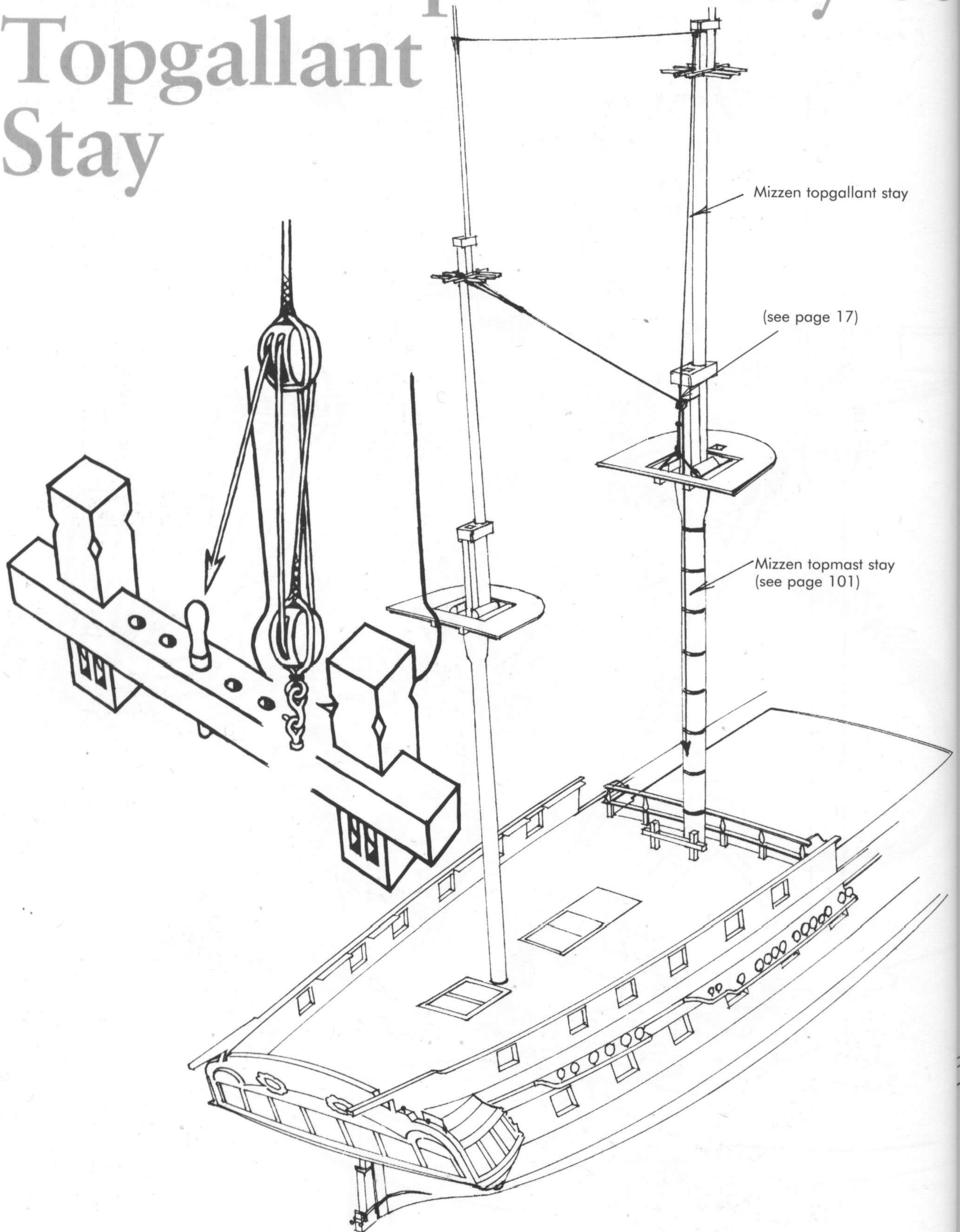

Main Topmast Stay, Preventer Stay, Topgallant & Royal Stay

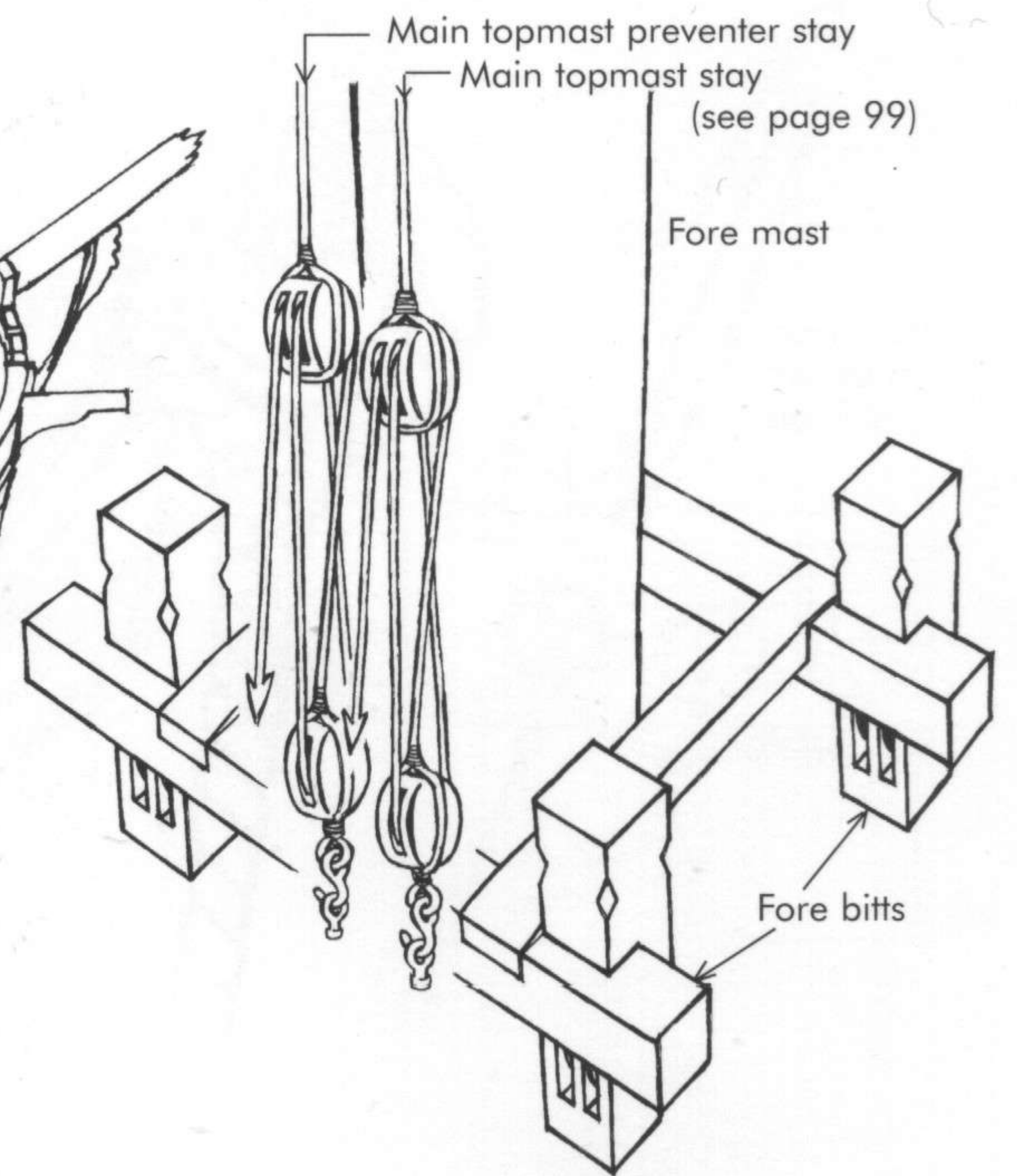
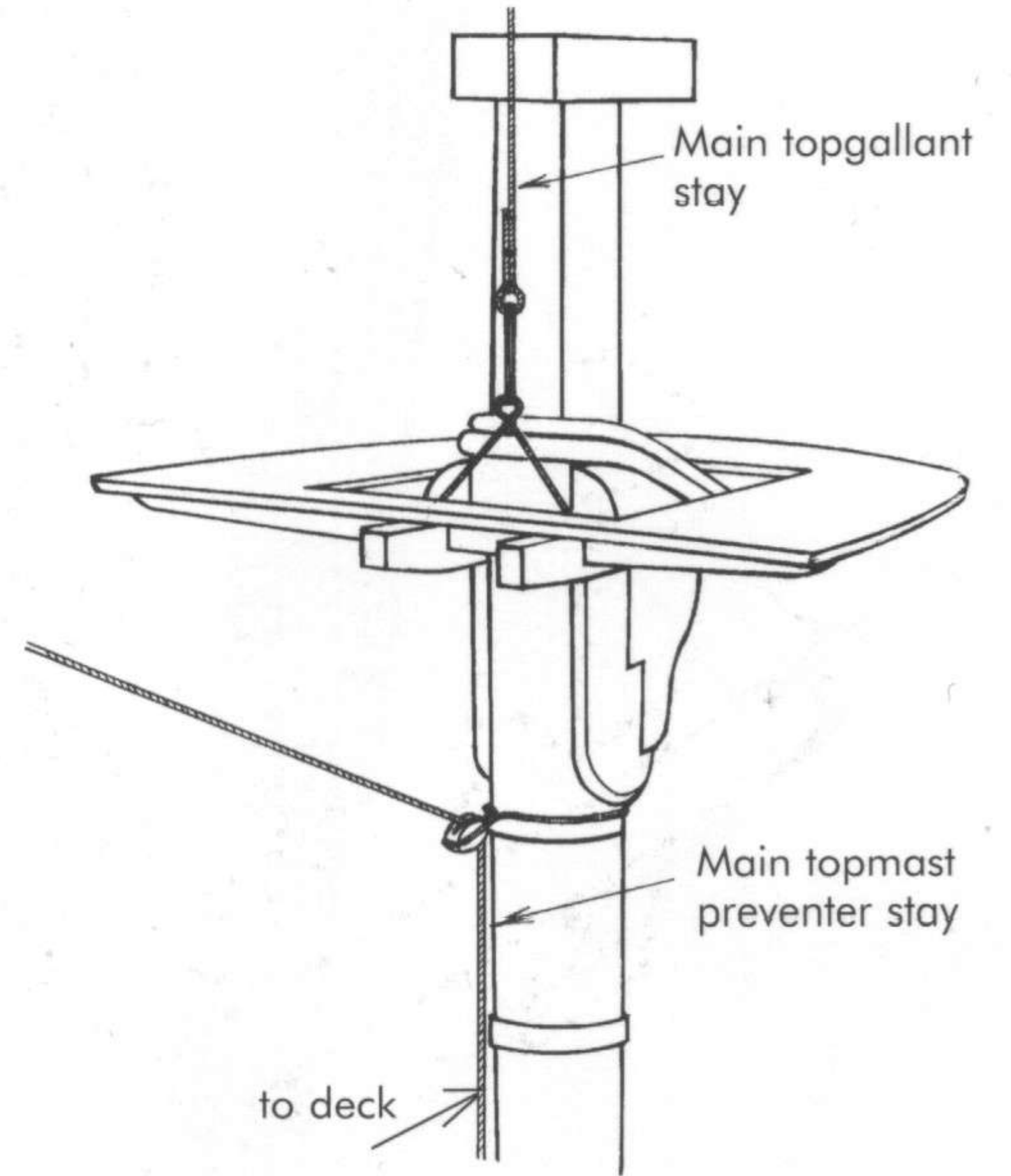
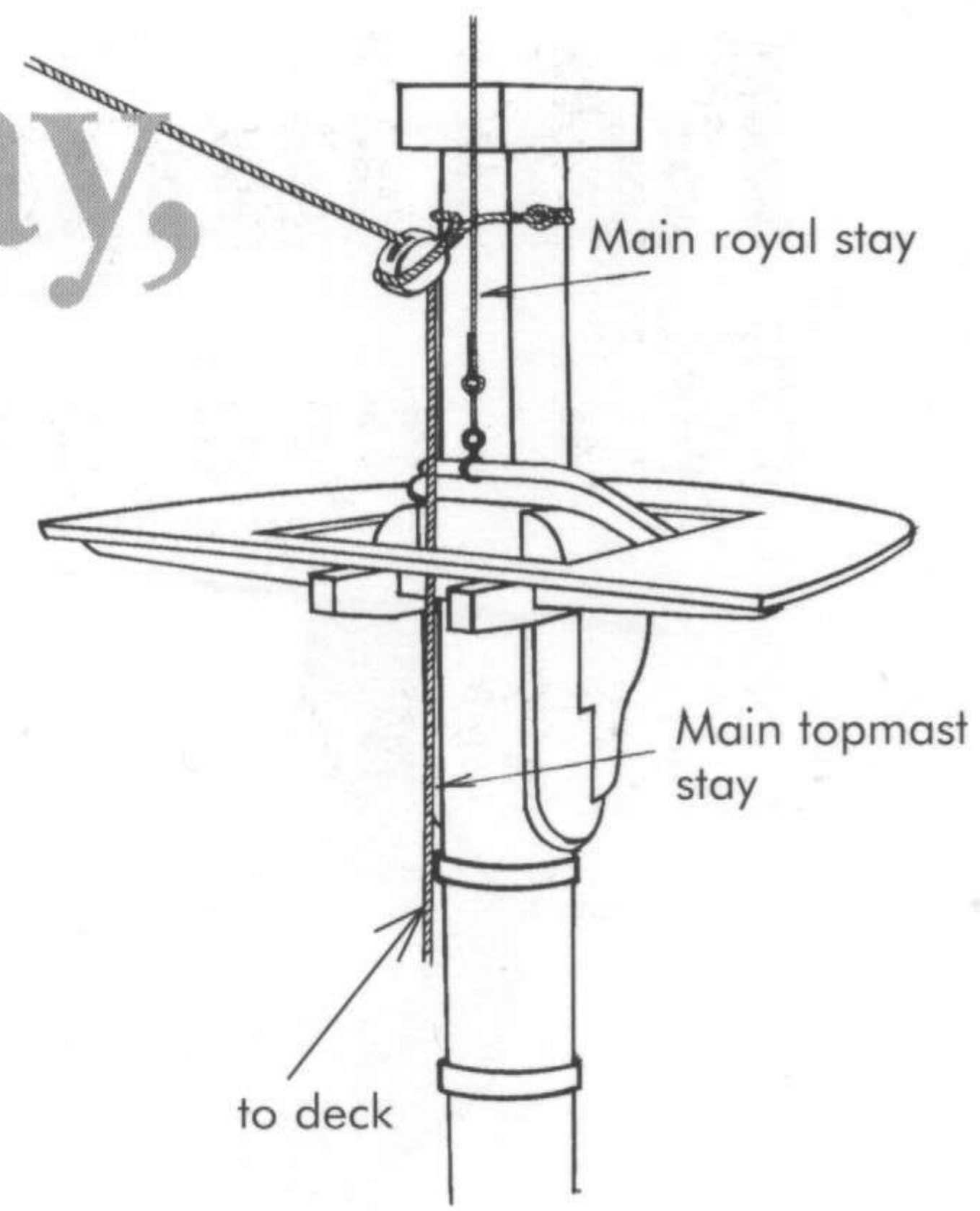
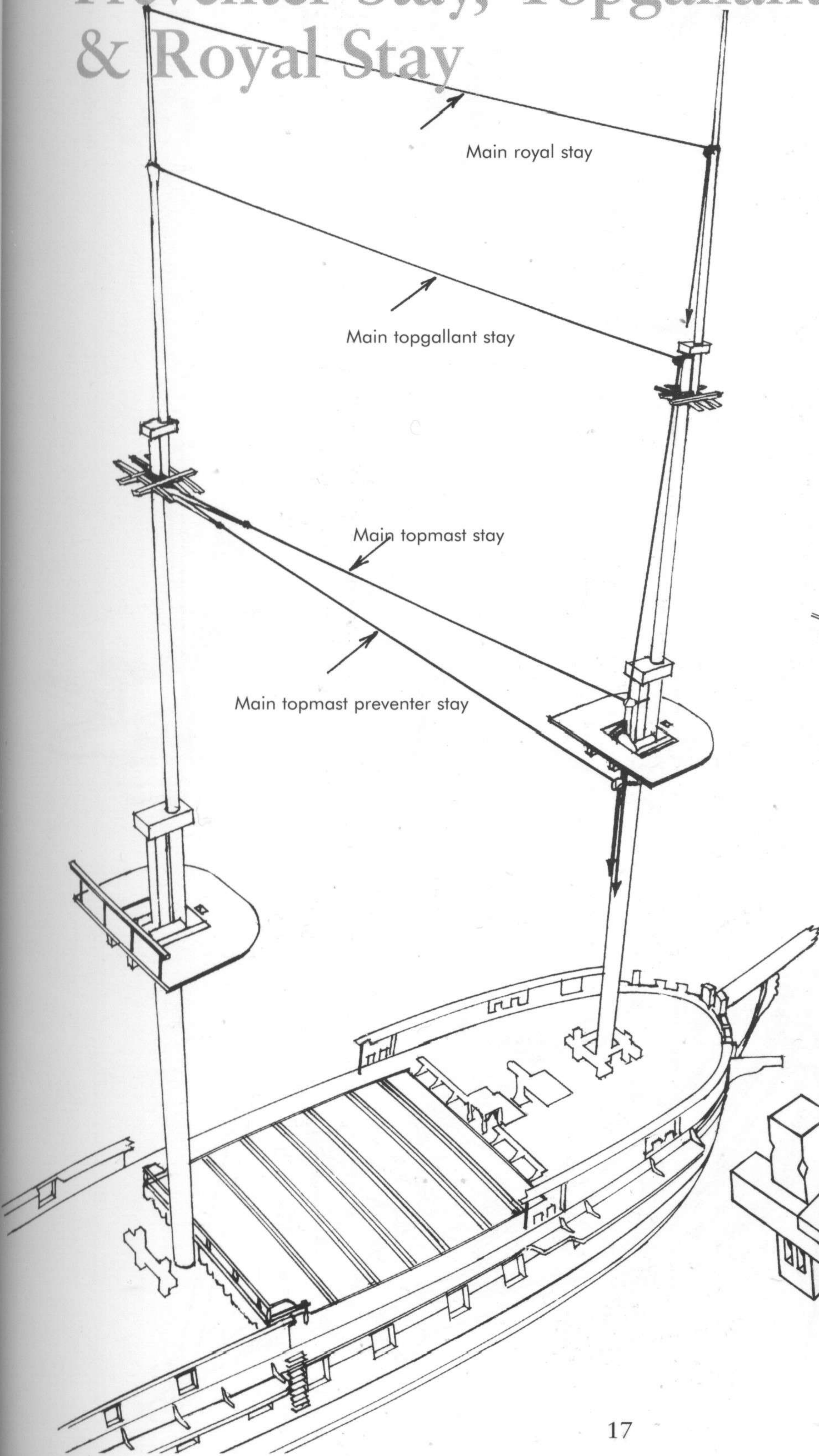

Fore Topmast & Preventer Stay

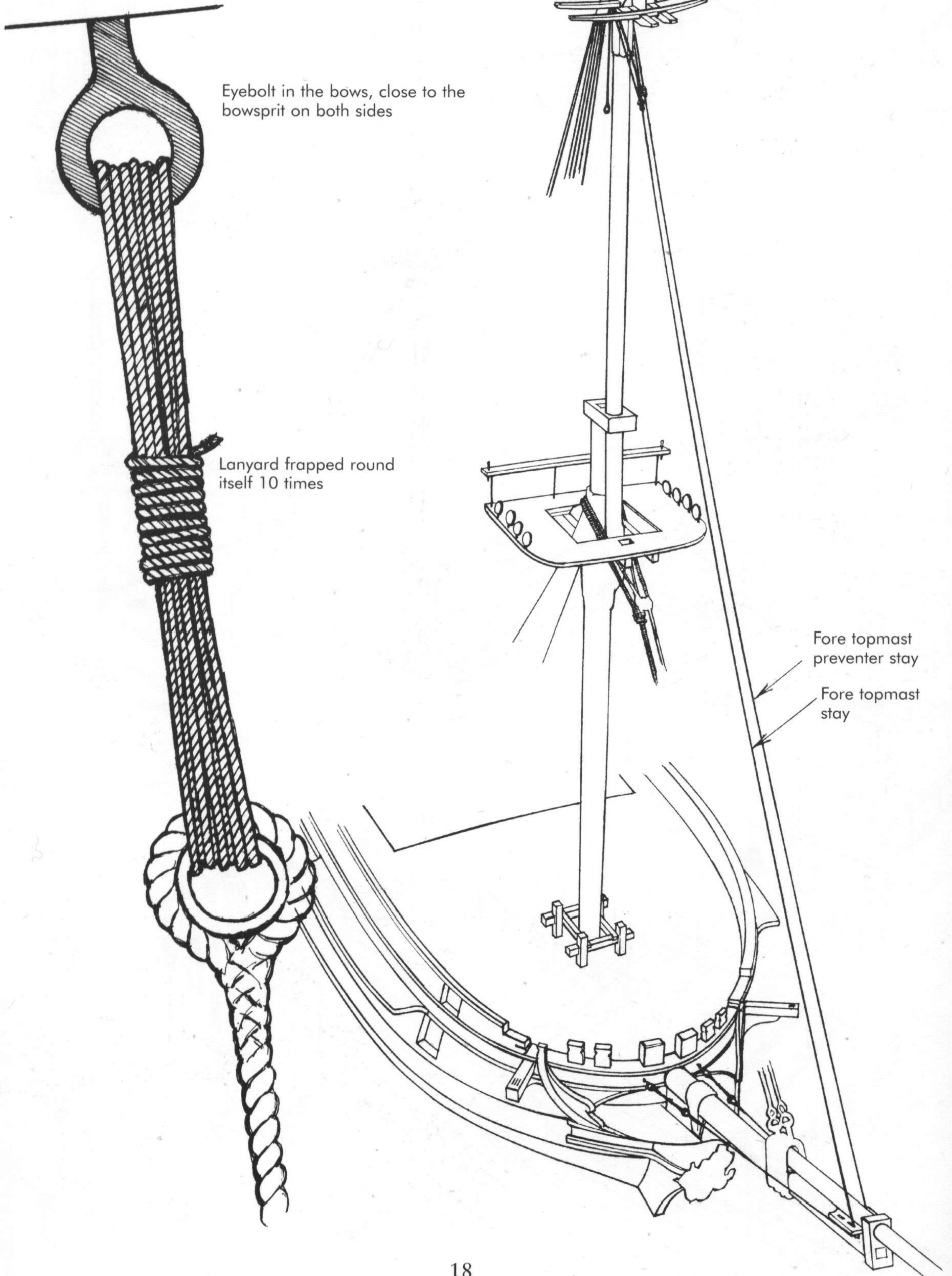

Jibstay, Fore Topgallant Flying Jib & Royal Stay

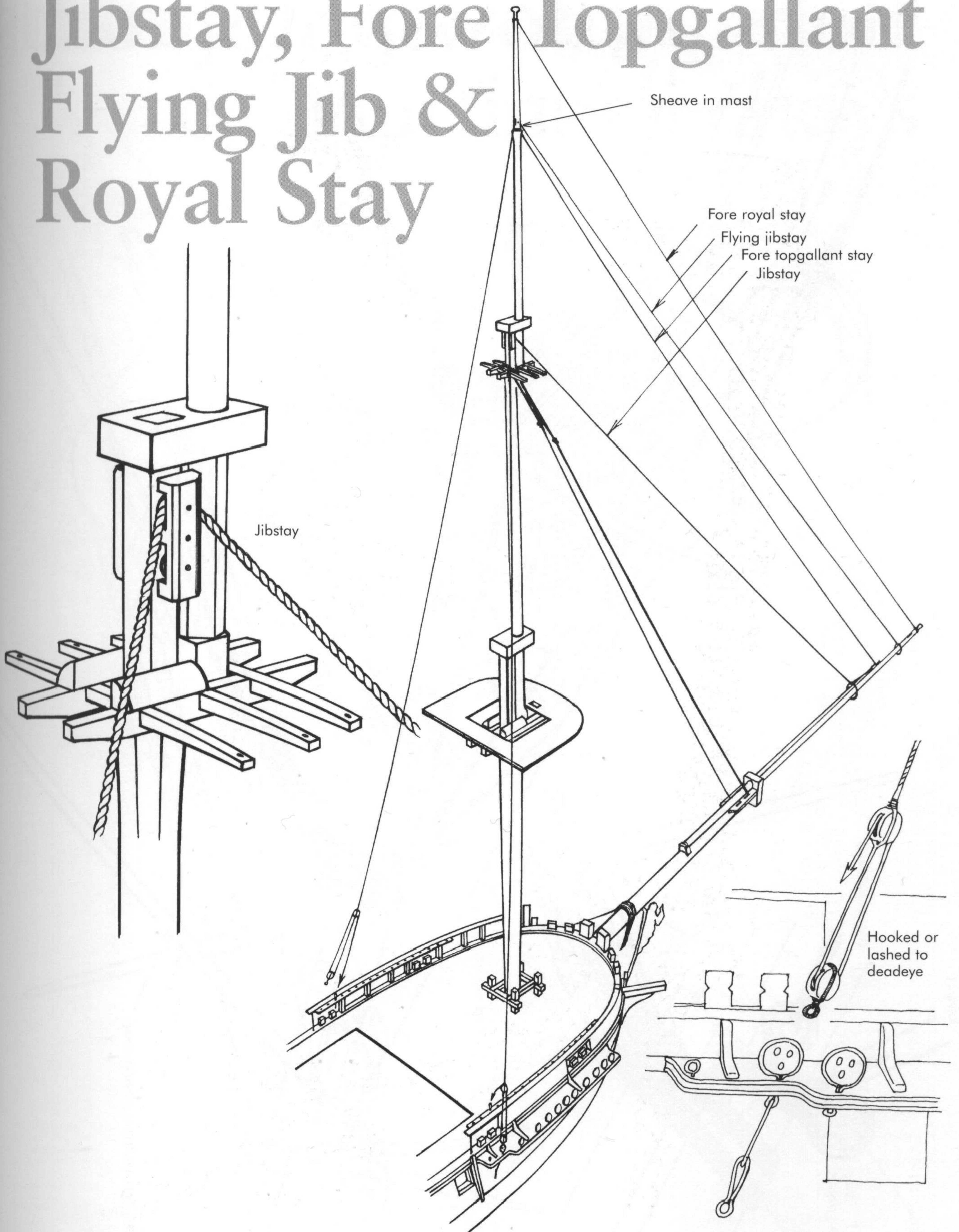

Bobstay, Bowsprit Shrouds

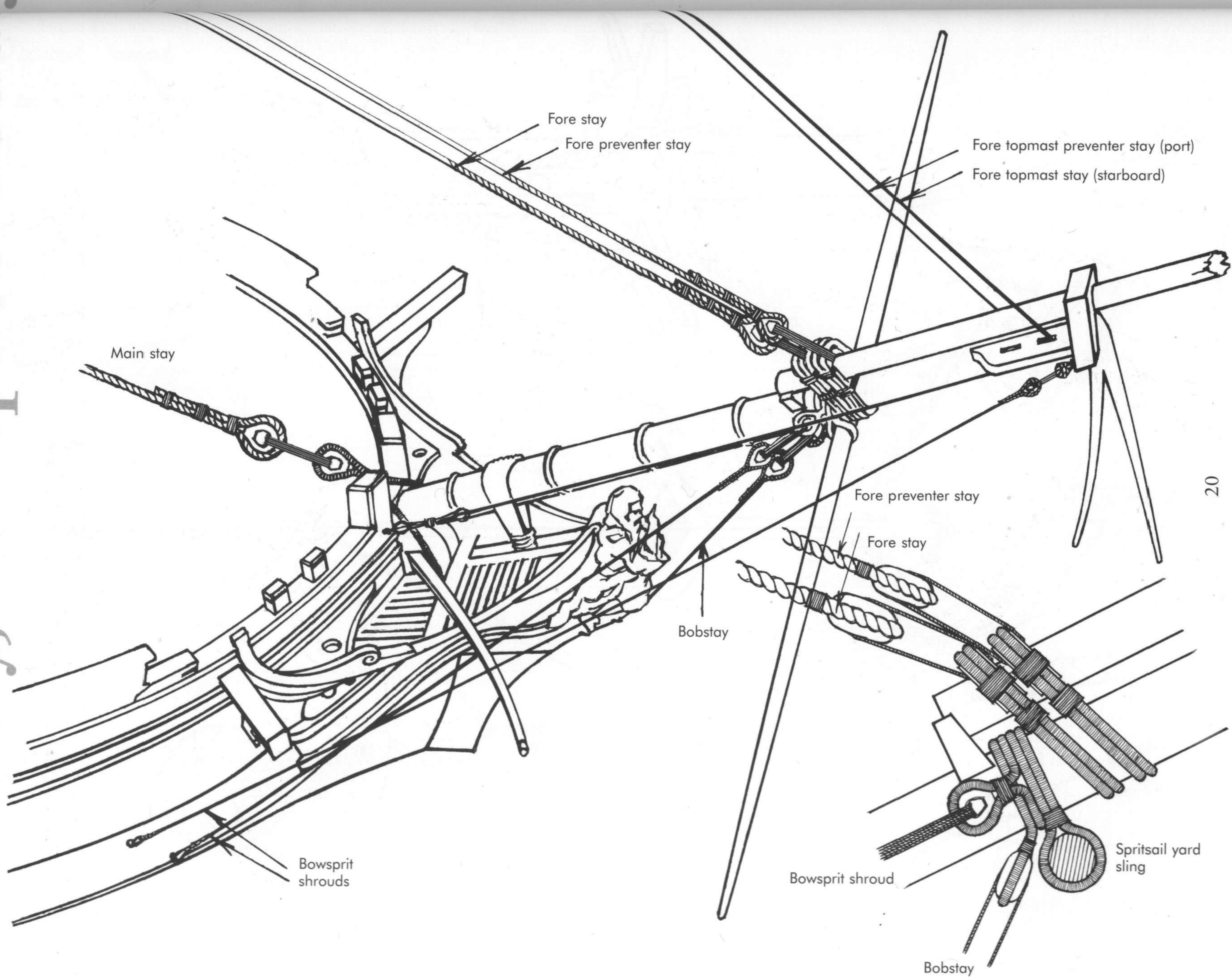

Jibstay & Martingale Stays

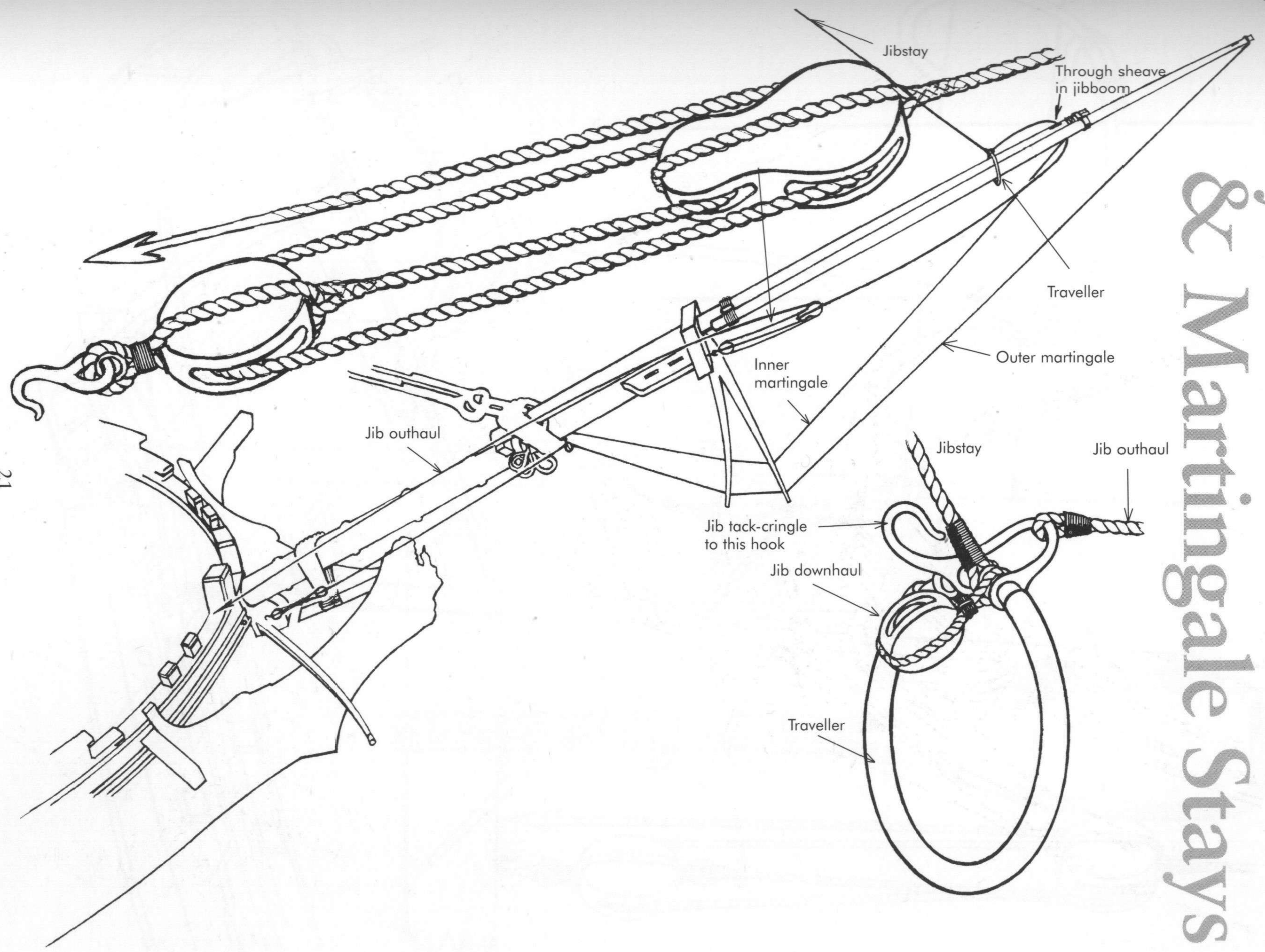

Cross Jack Truss Pendant

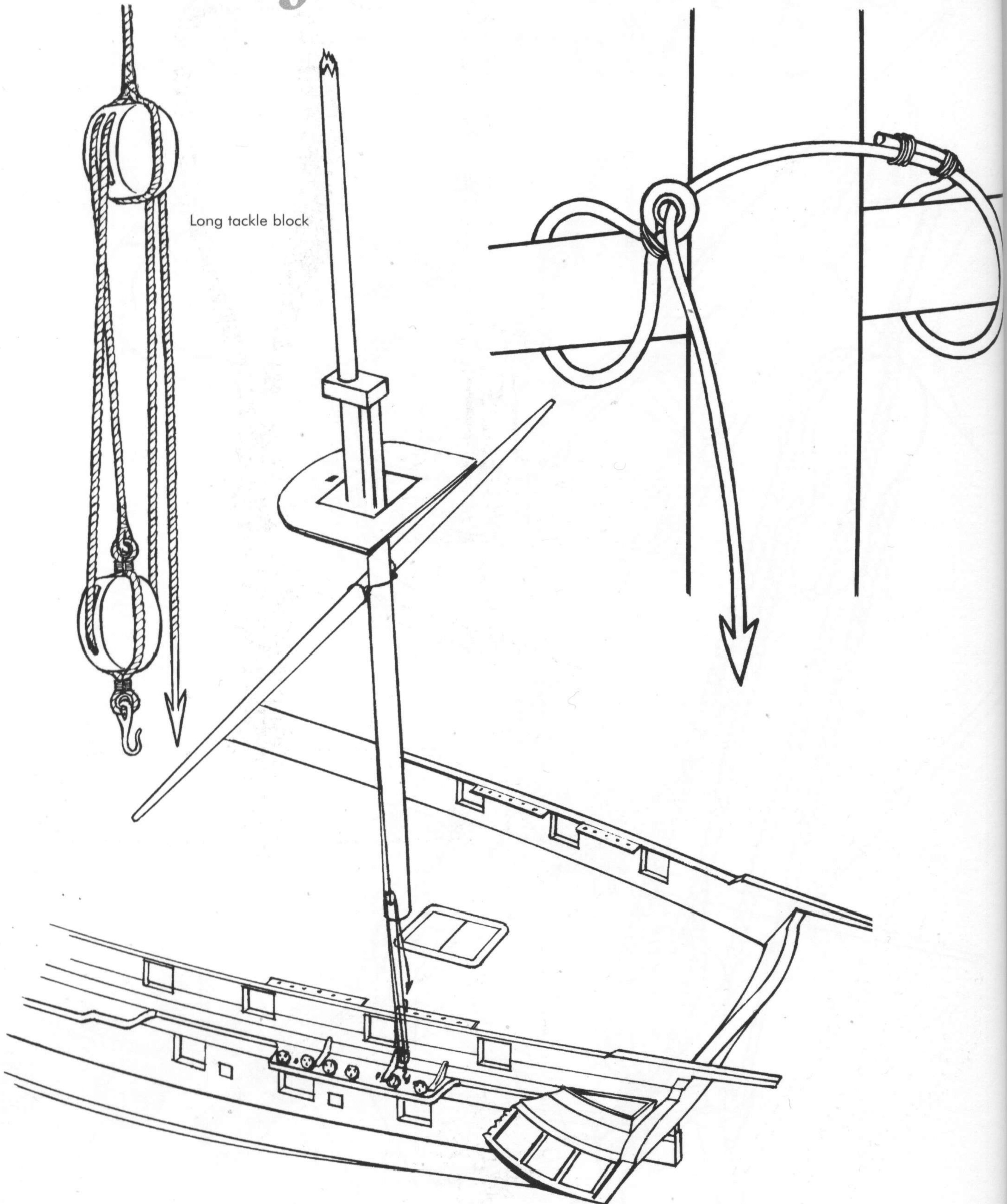

Cross Jack Sling

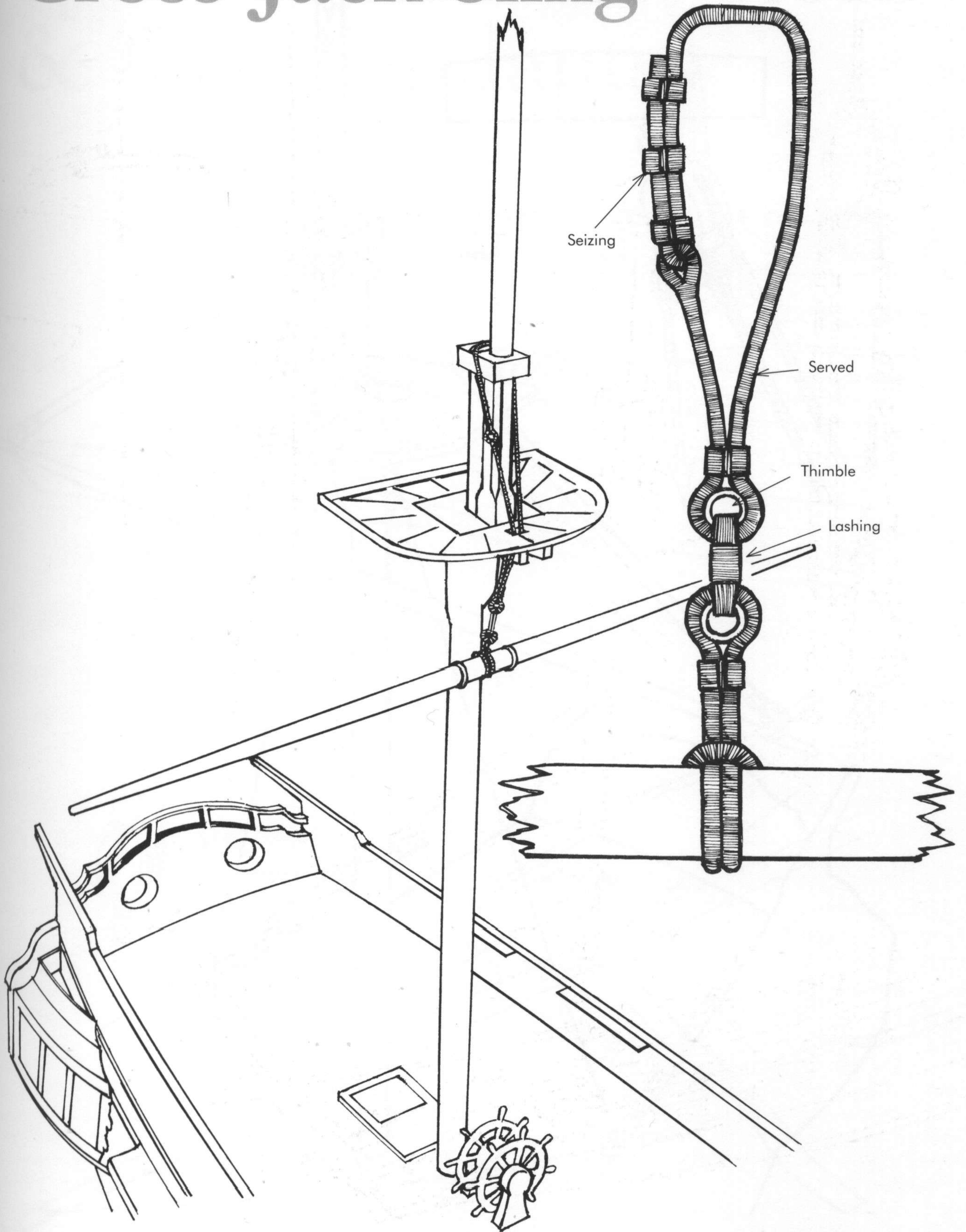

Cross Jack Lift

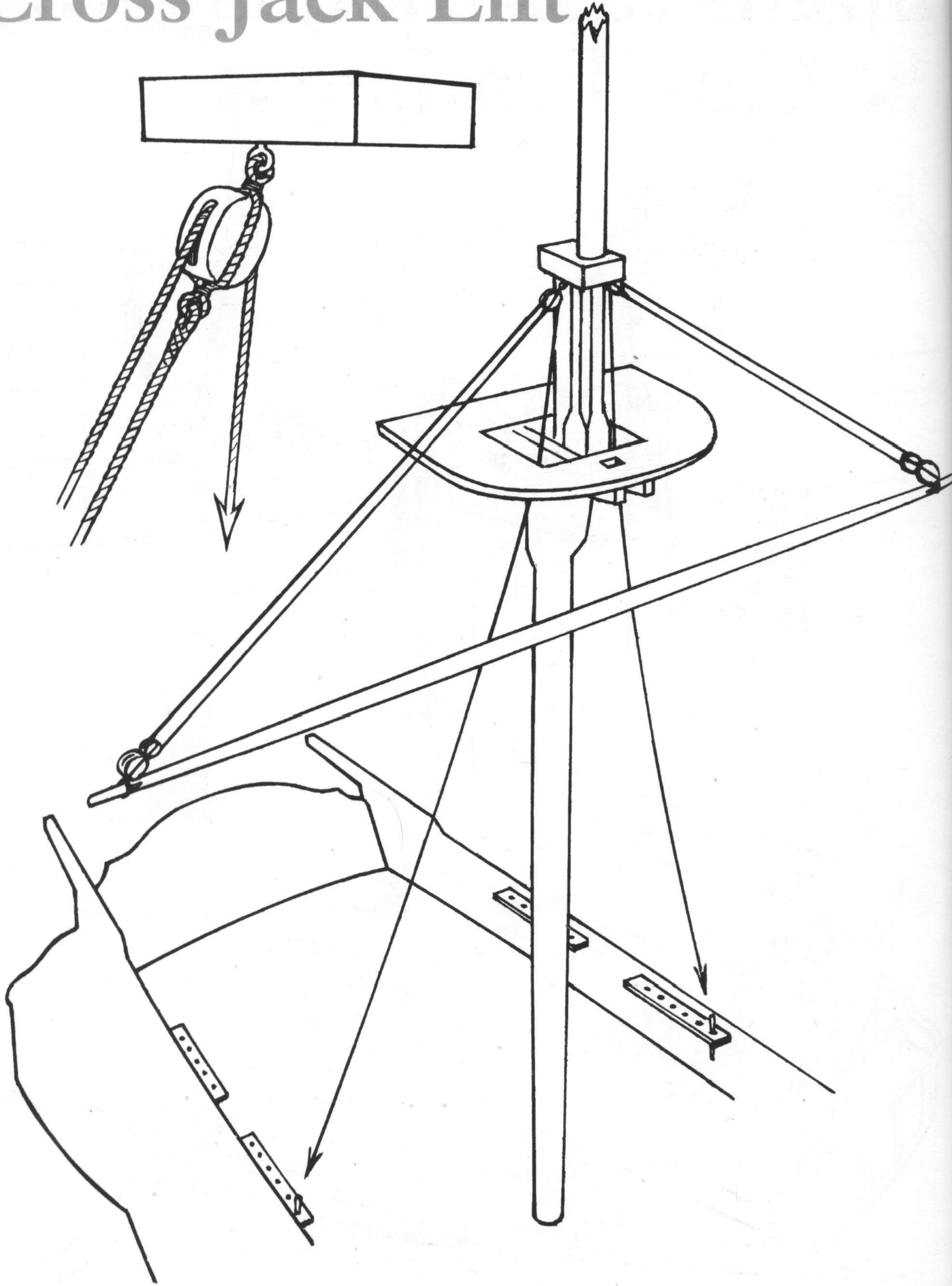

Spanker Boom Sheet & Guy Pendants

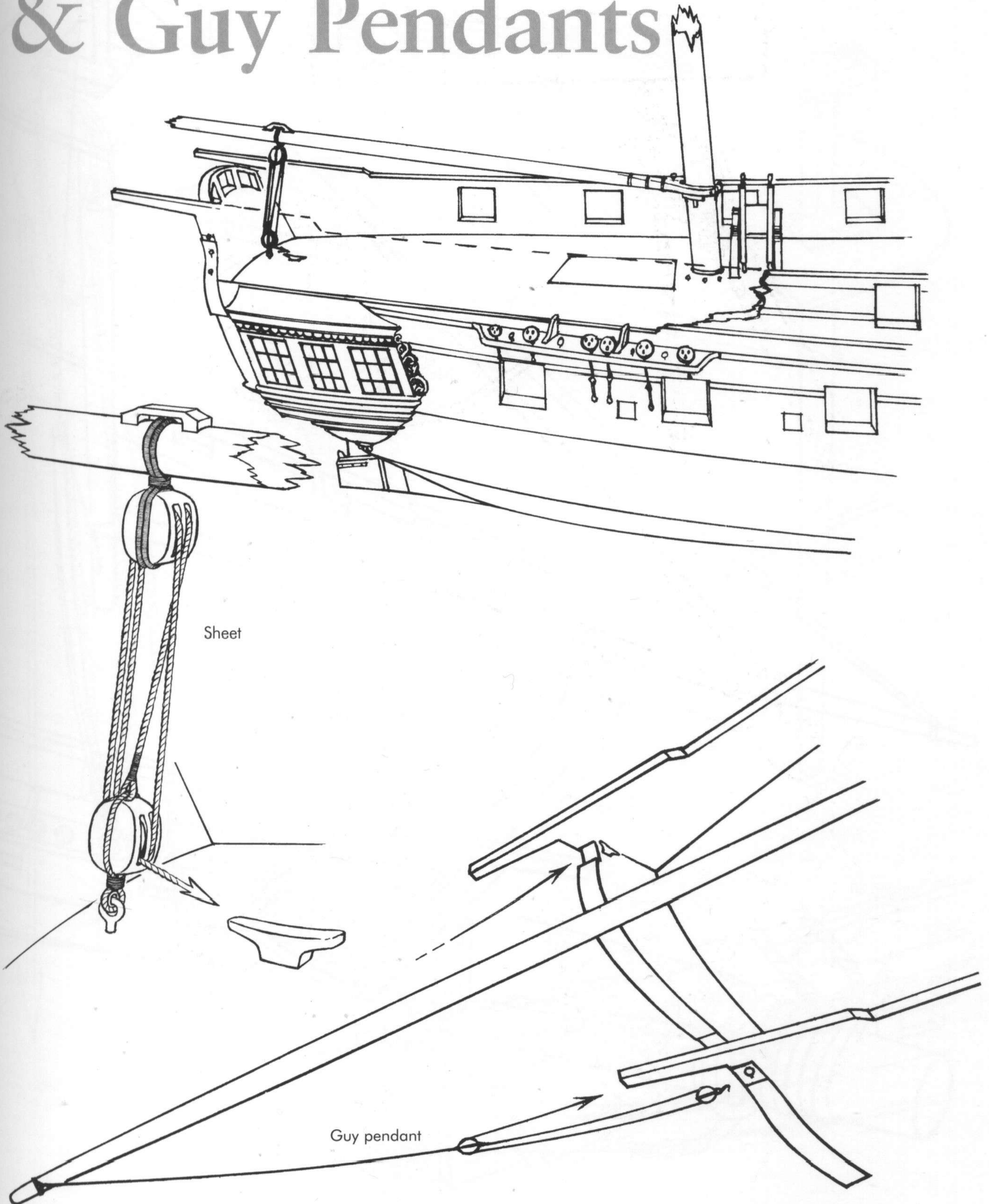

Boom Topping Lift

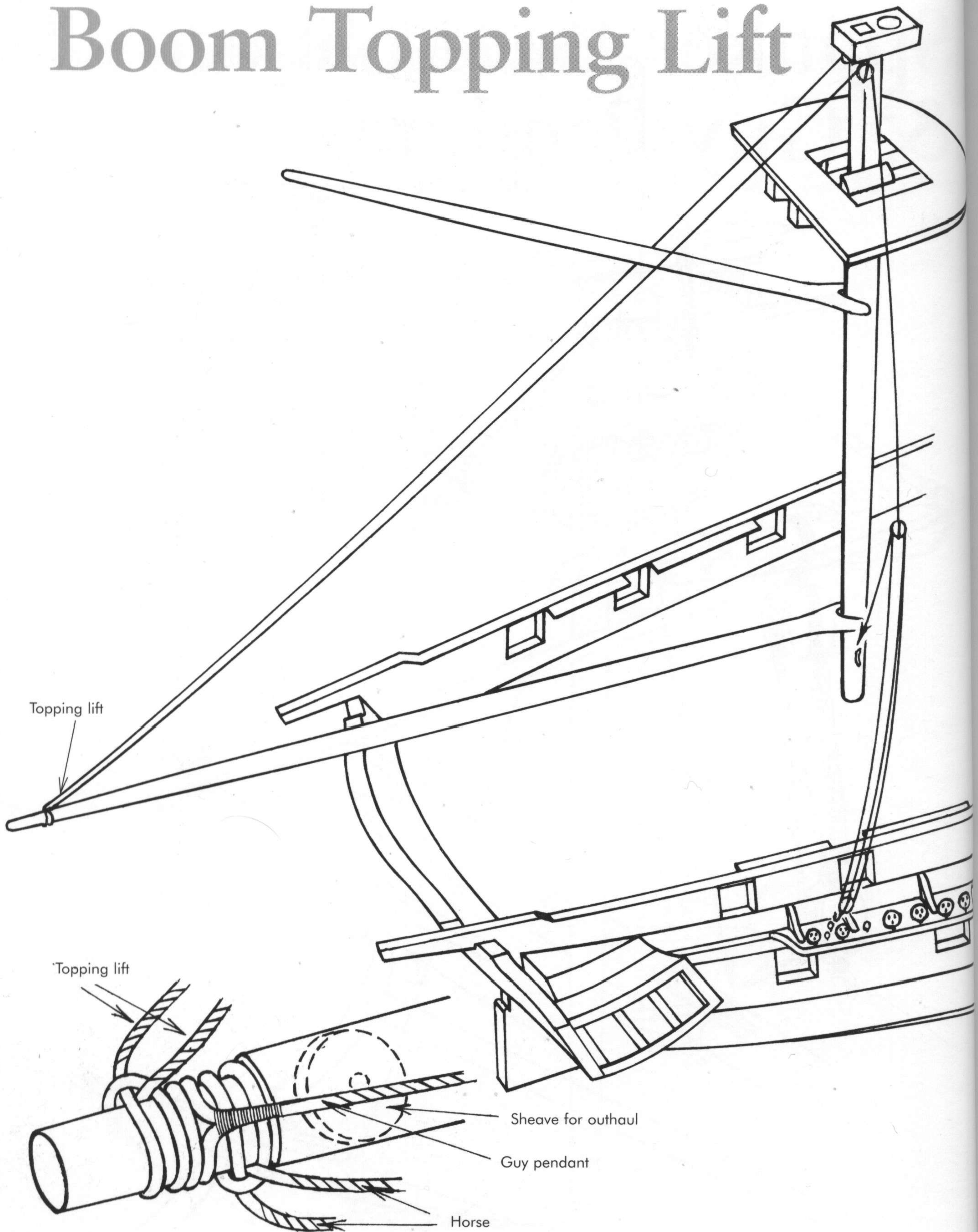

Vangs

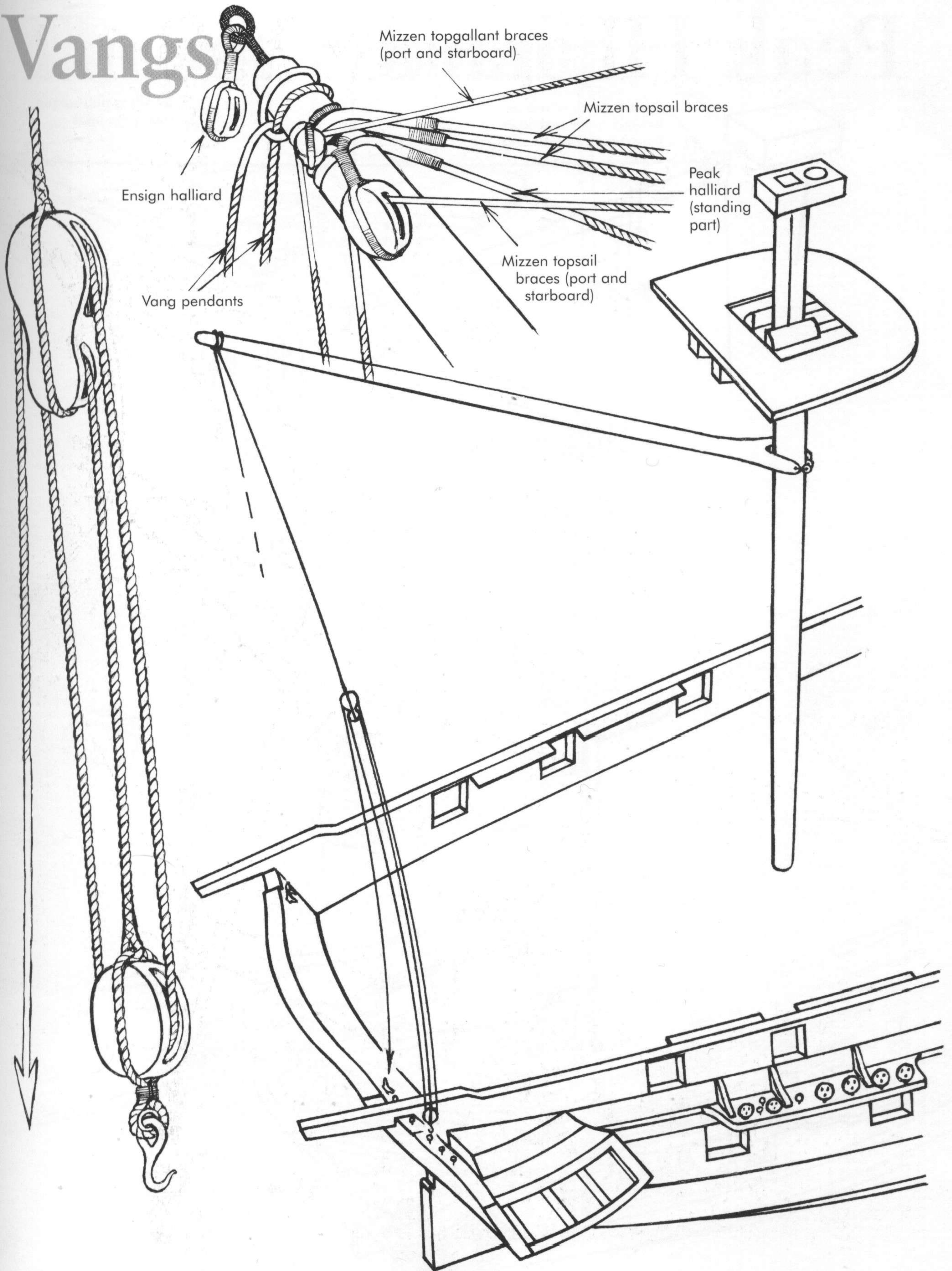

Peak Halliard

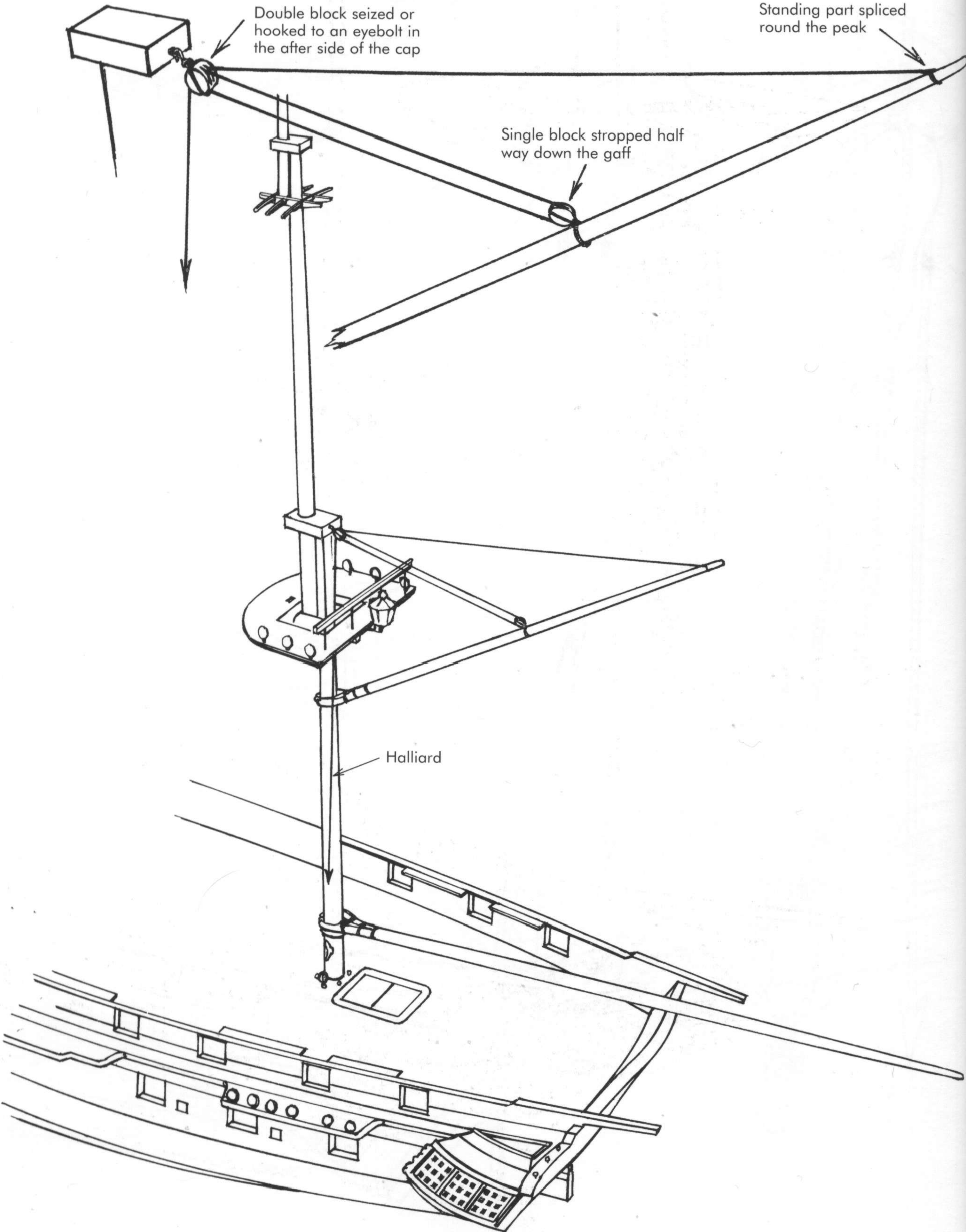

Throat Halliard

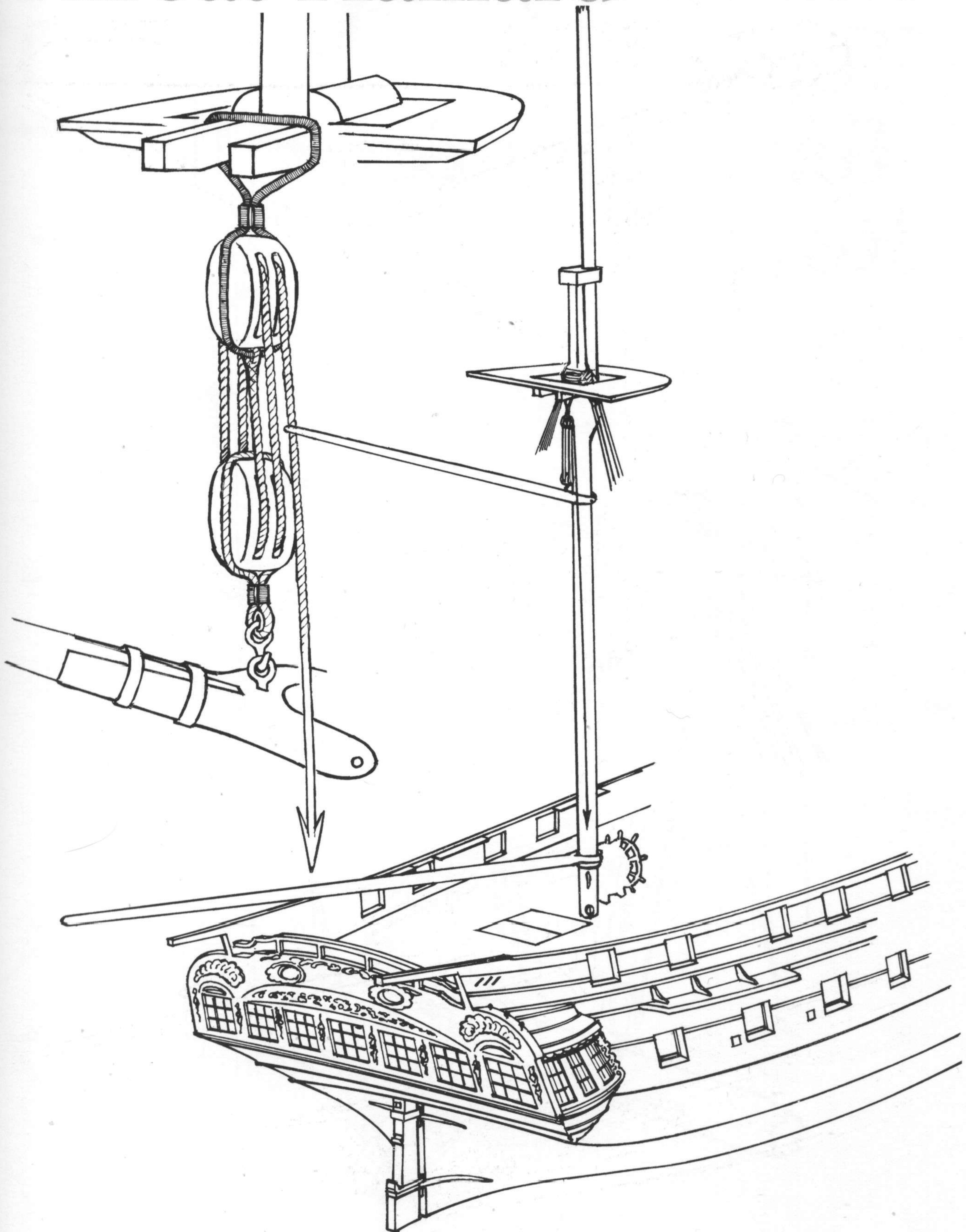

Mizzen Tye: Topsail, Topgallant & Royal Yard

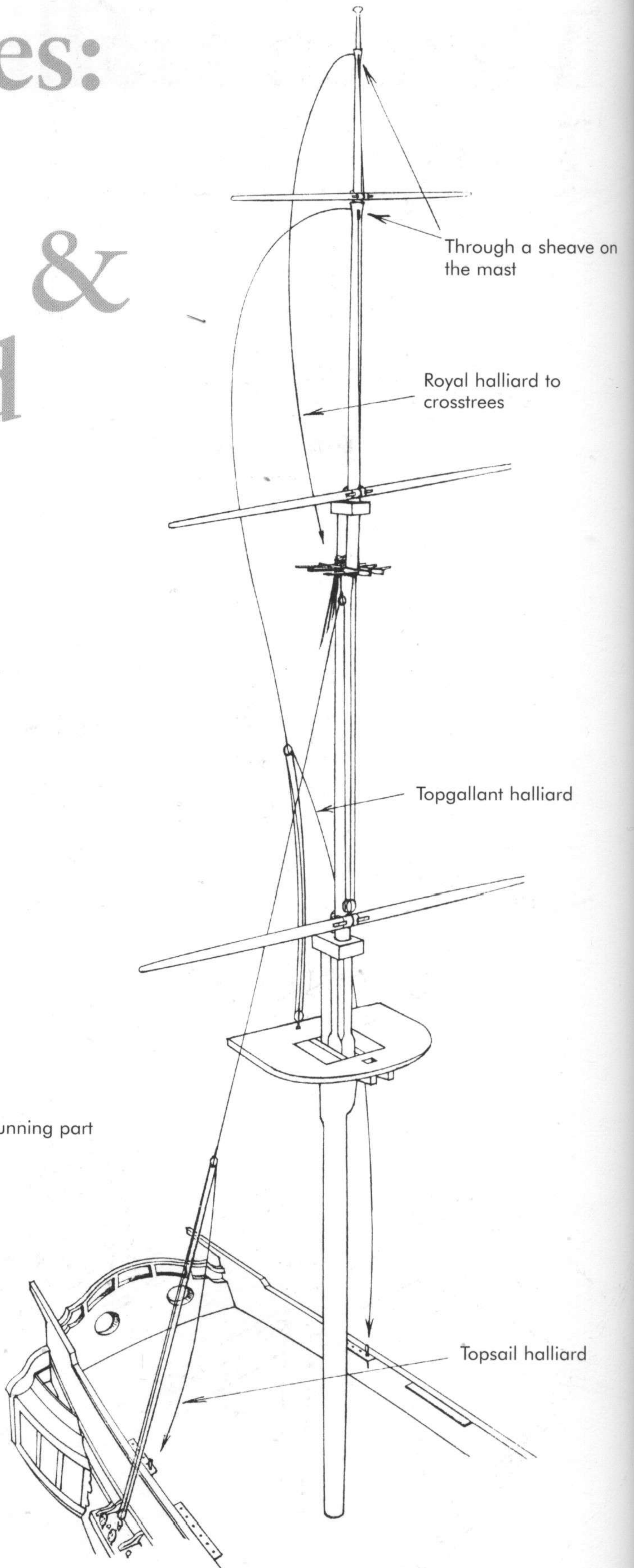
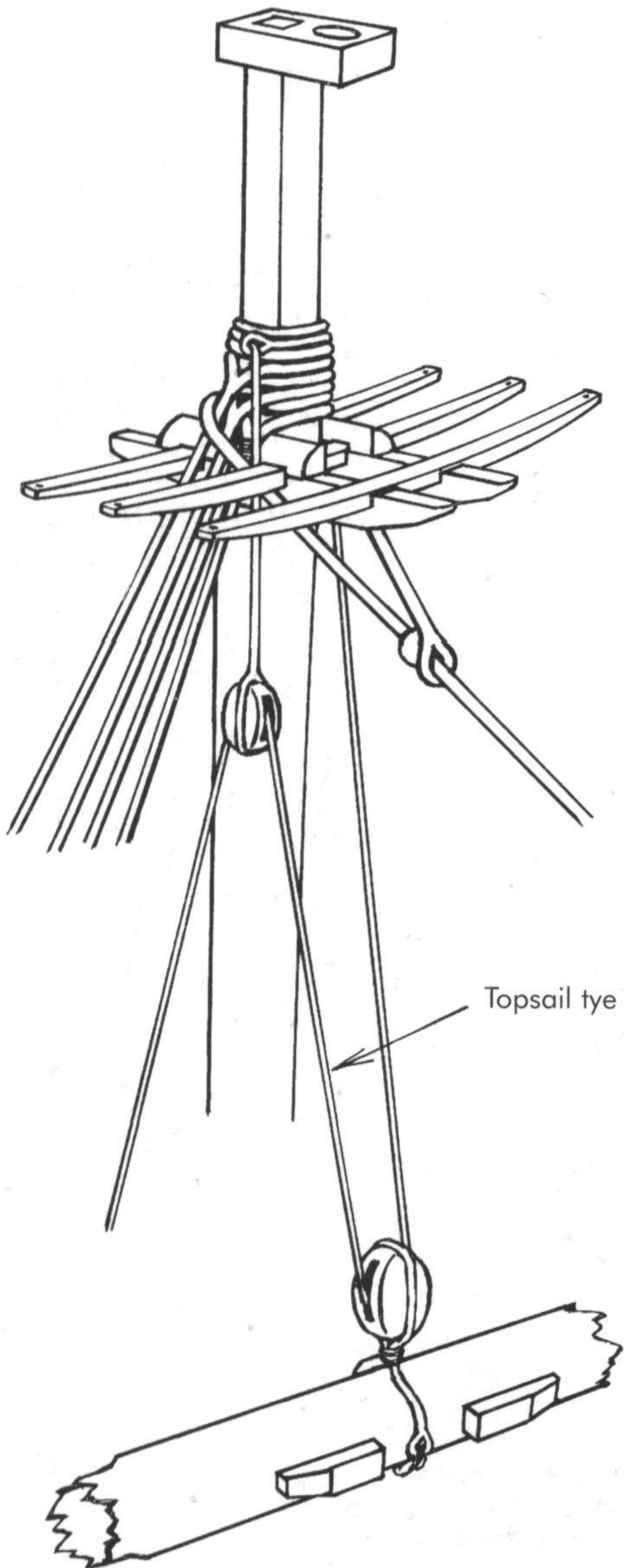

Mizzen Lifts: Topsail & Topgallant

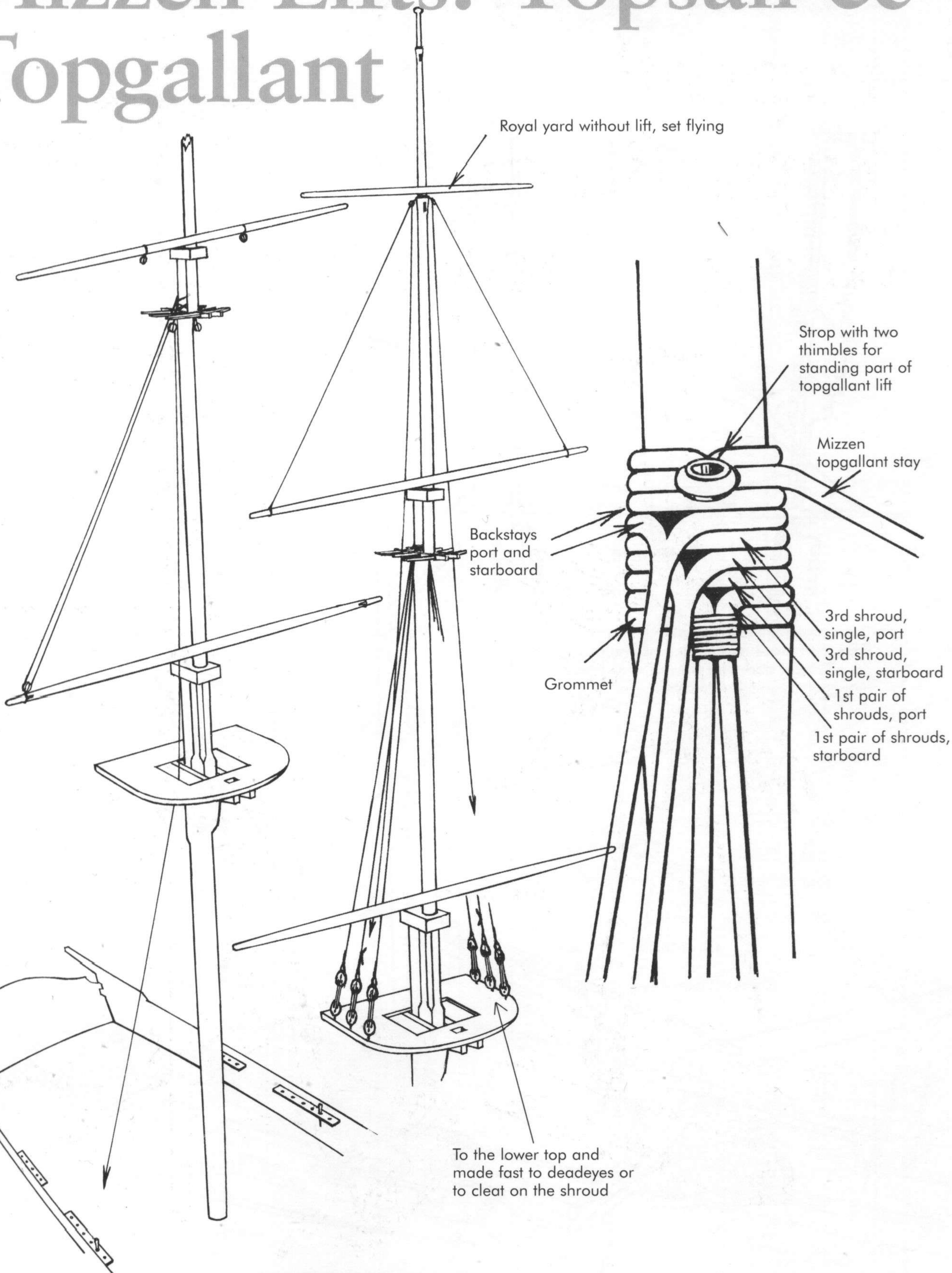

Cross Jack Braces

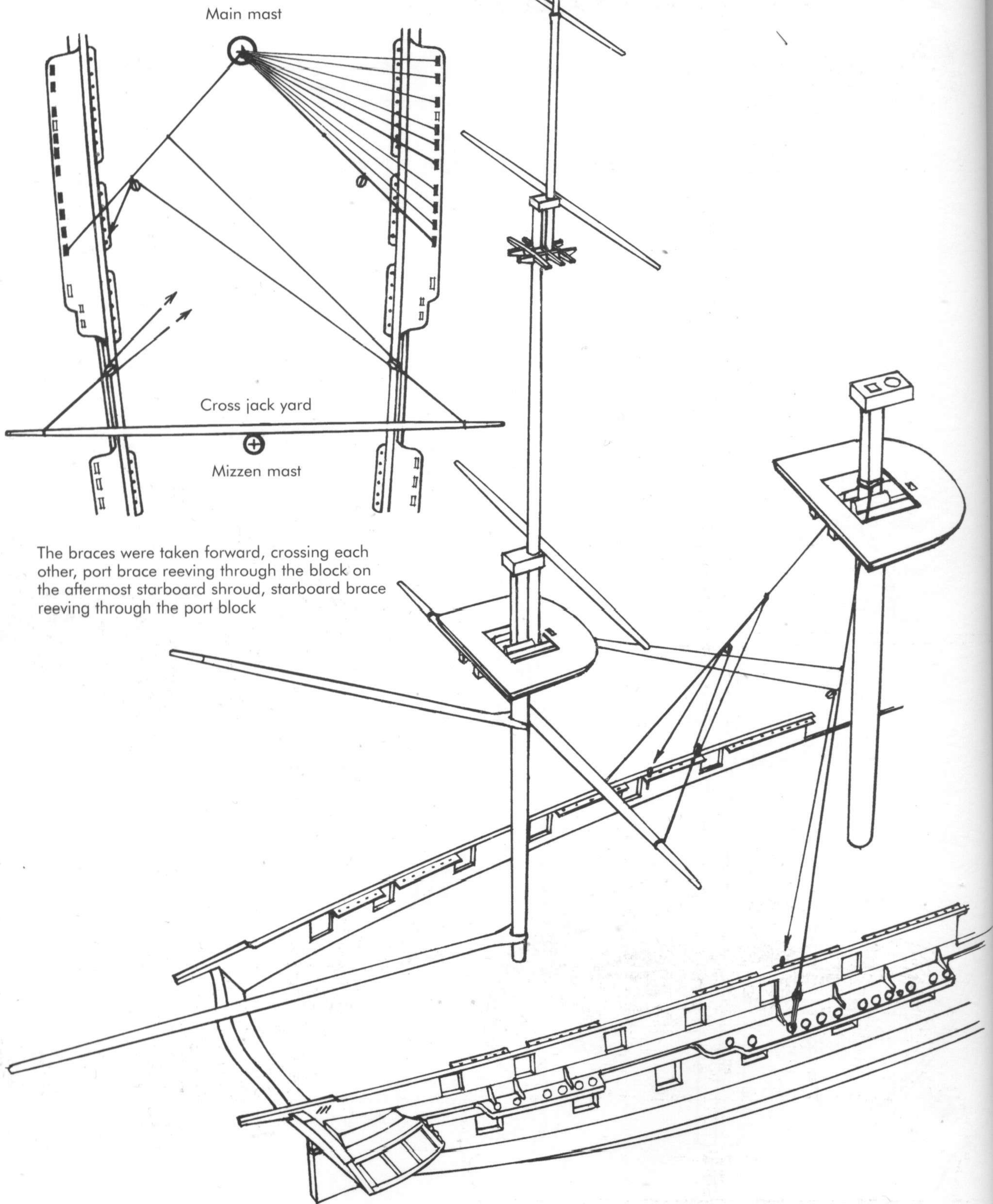

The braces were taken forward, crossing each other, port brace reeving through the block on the aftermost starboard shroud, starboard brace reeving through the port block

Mizzen Topsail & Topgallant Braces

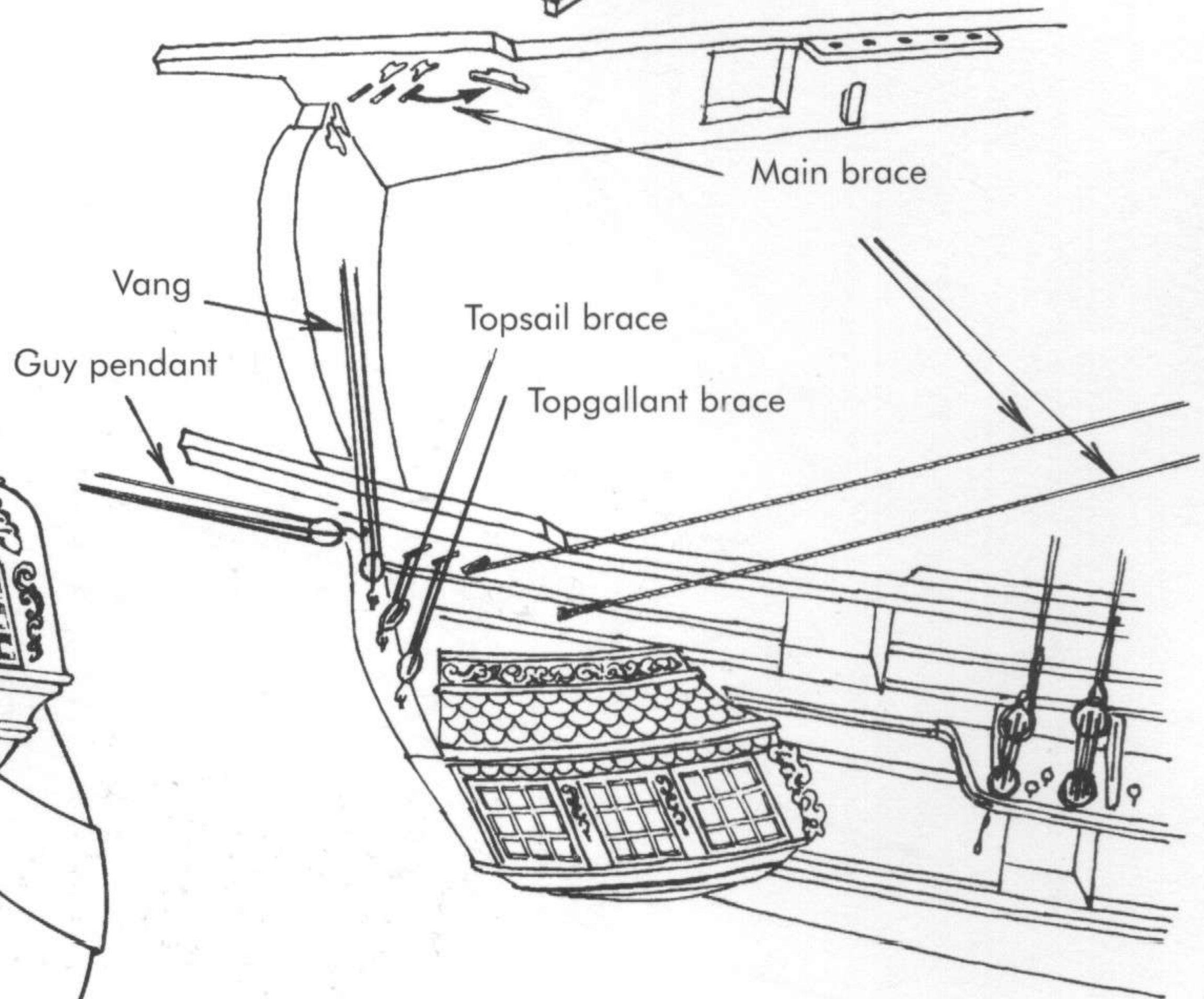
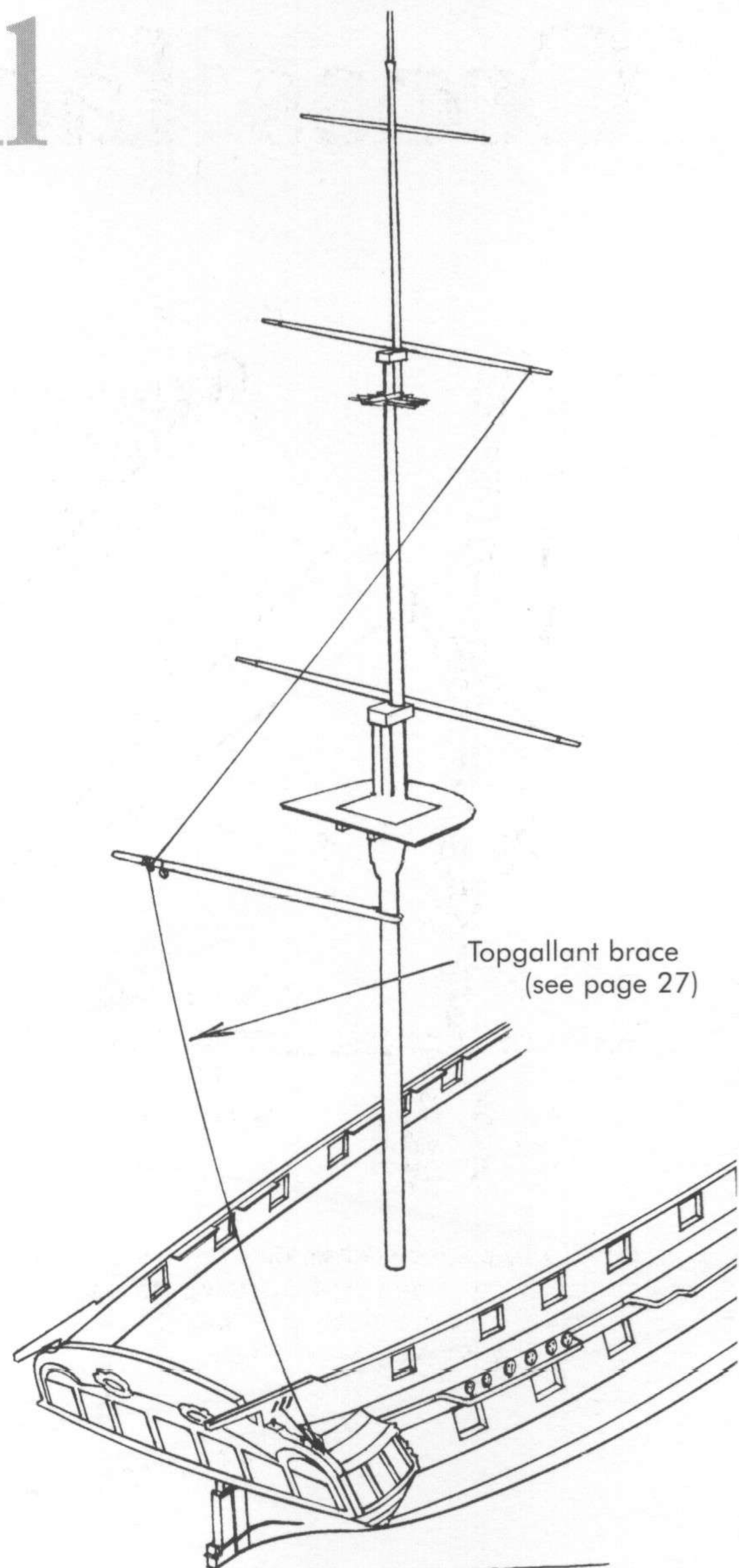
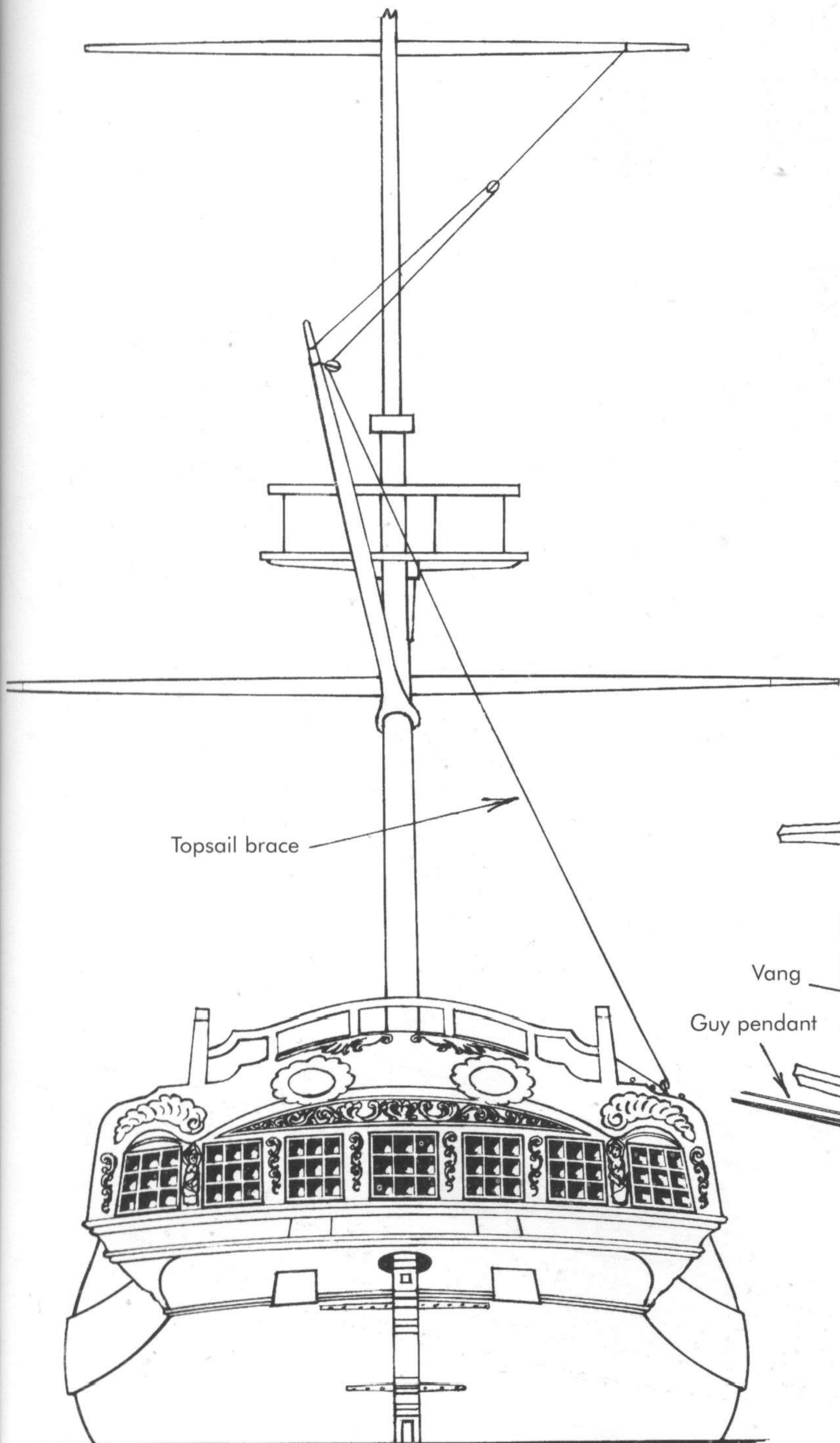

Fore & Main Slings

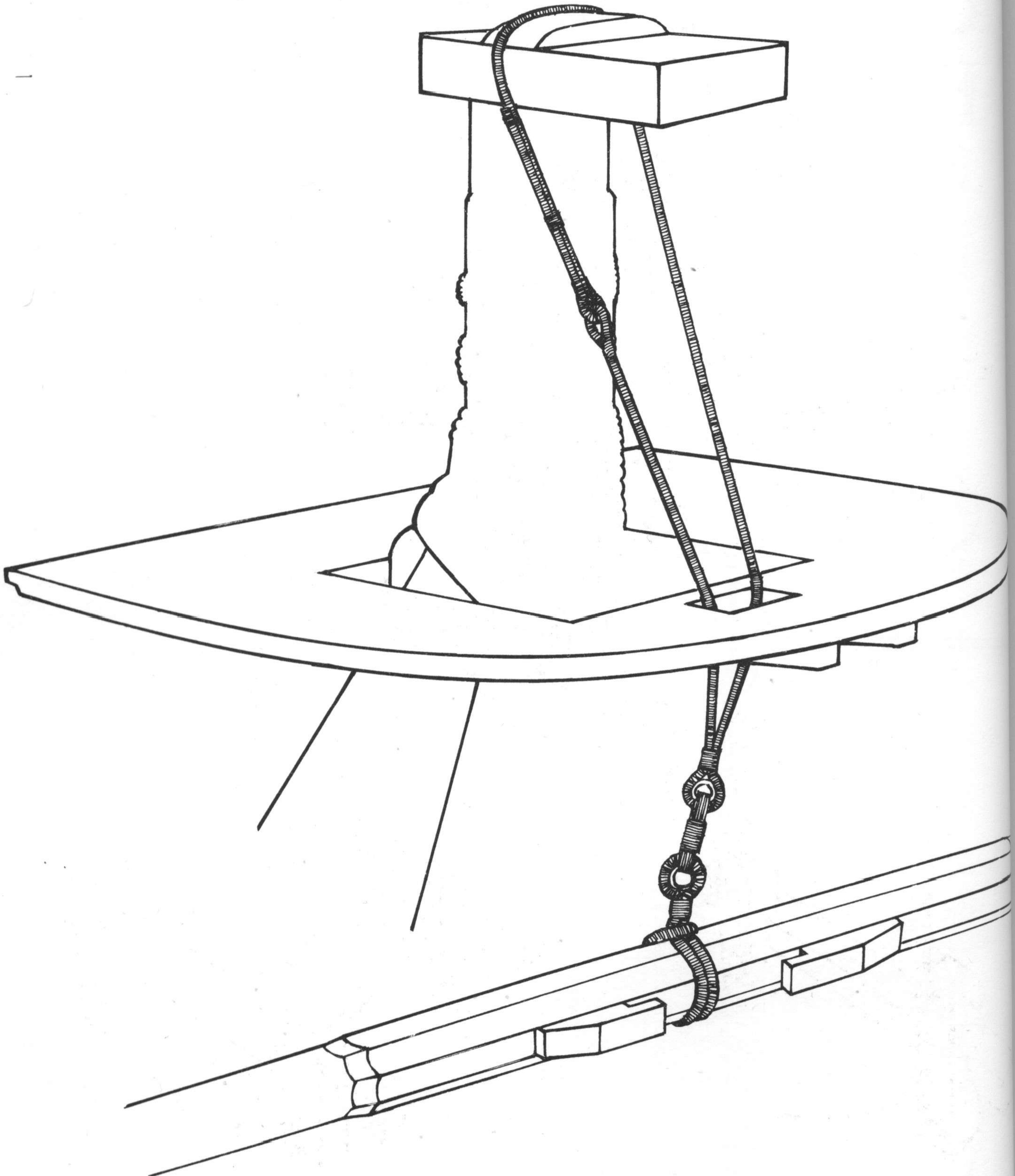

Fore & Main Jeers

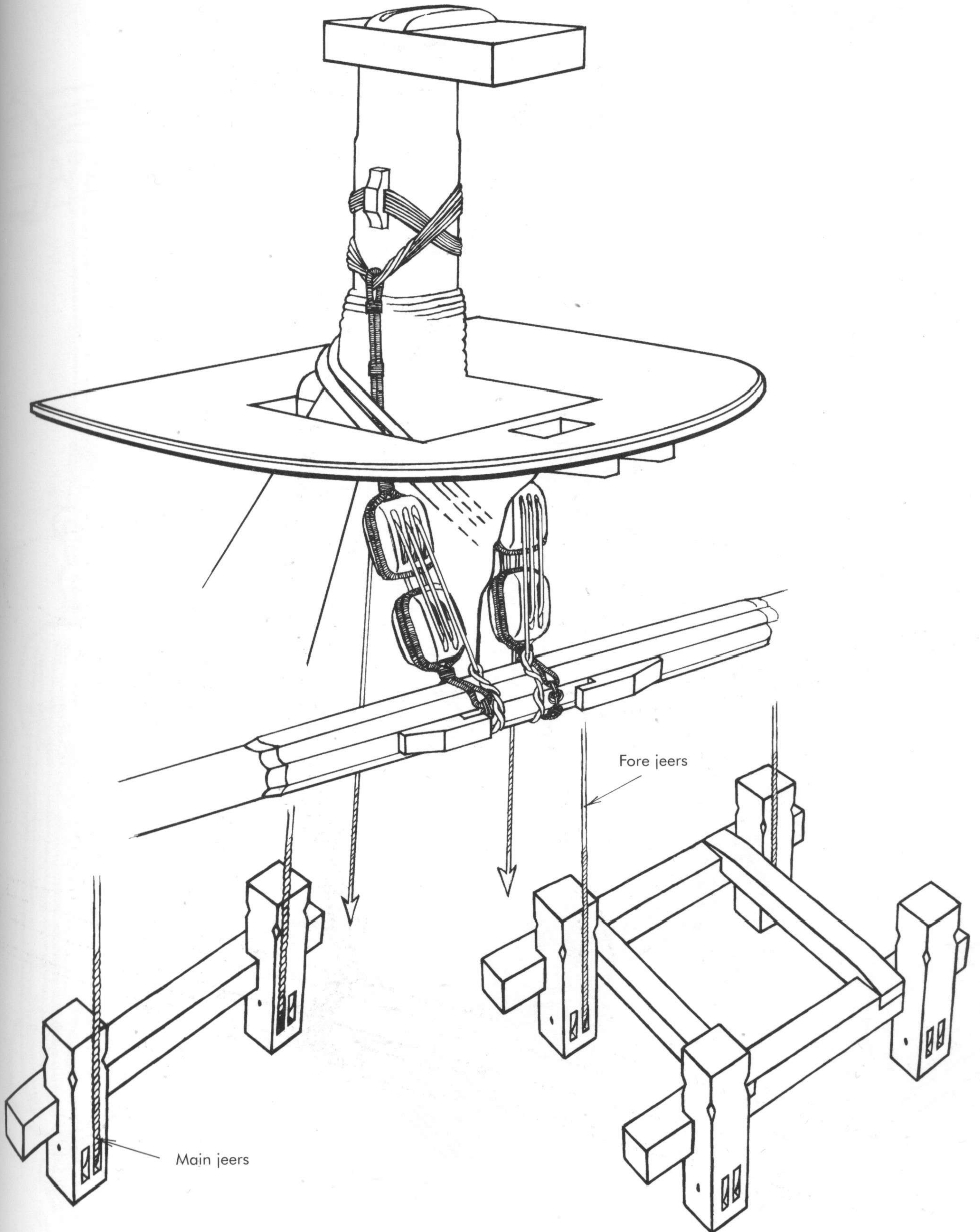

Truss Pendants & Nave Line

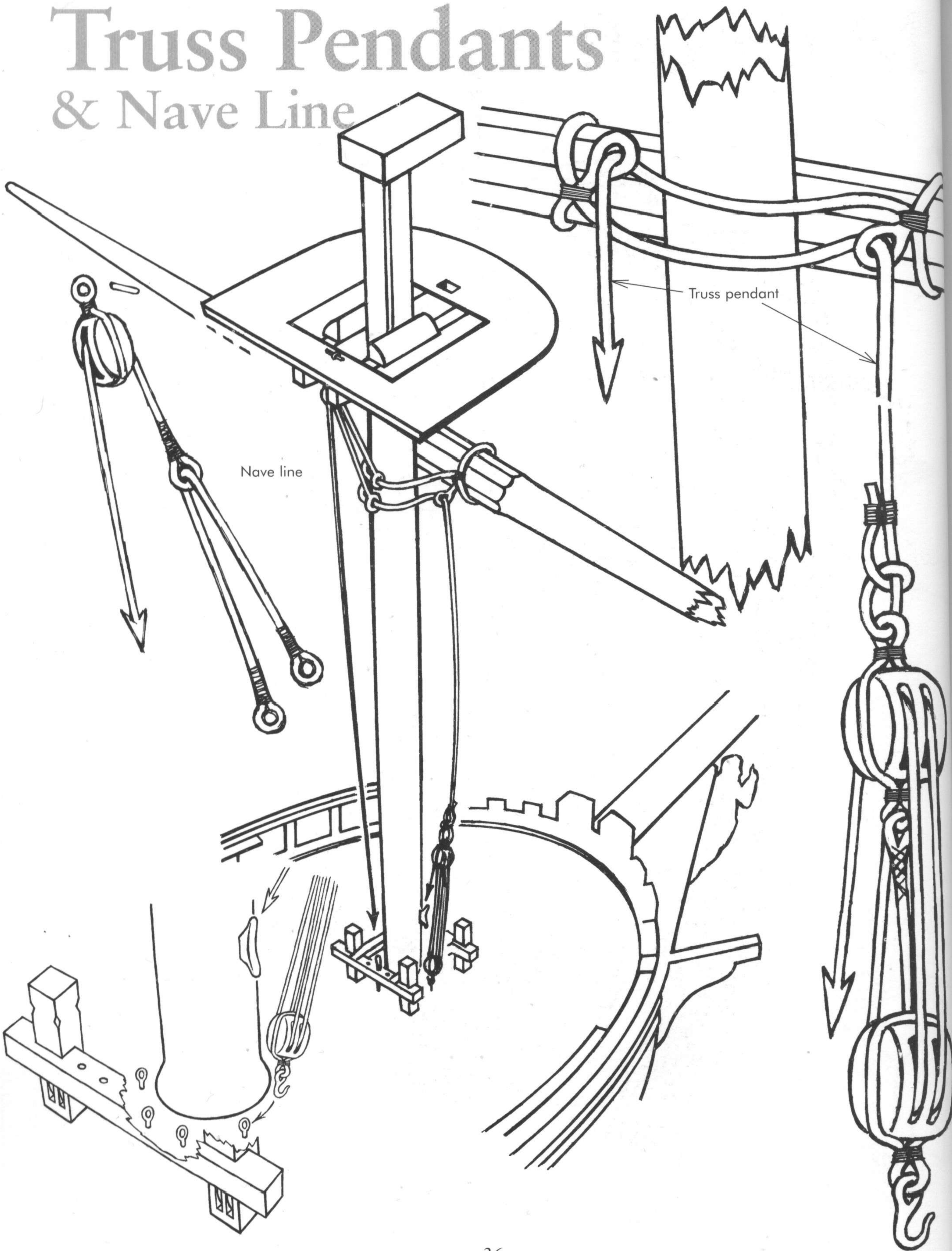

Main Lift

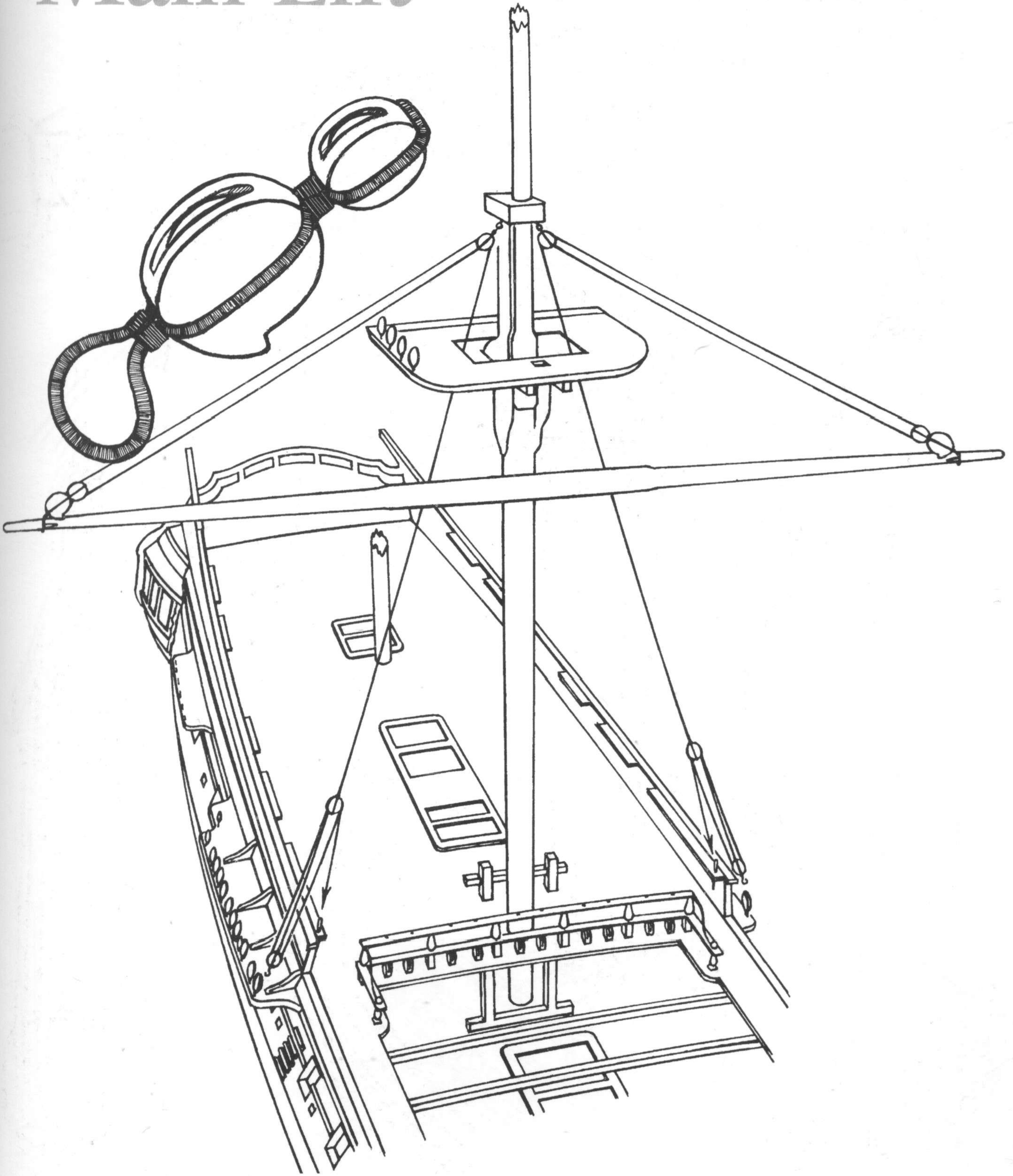

Fore Lift

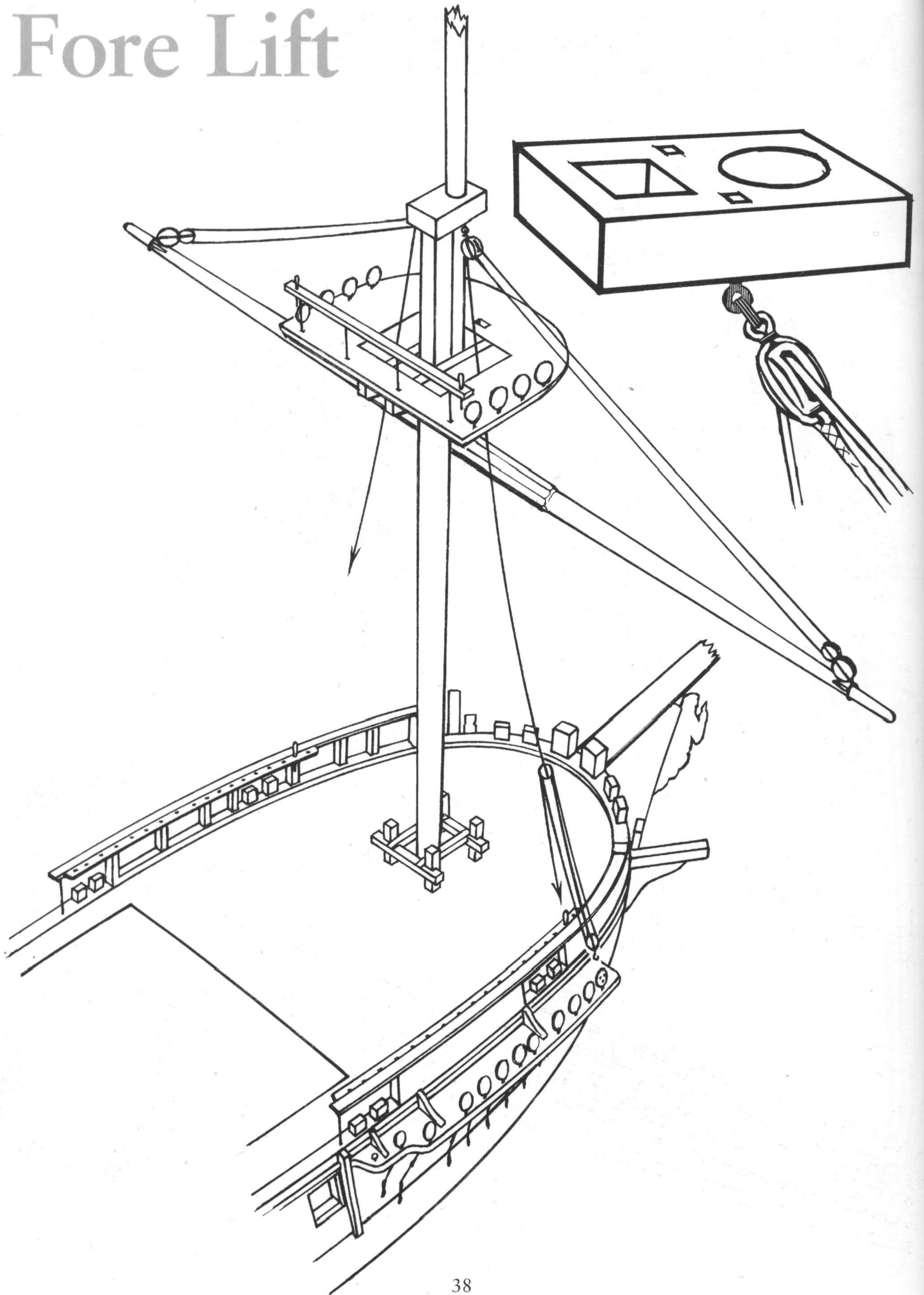

Fore Topsail Yard Tye & Halliard

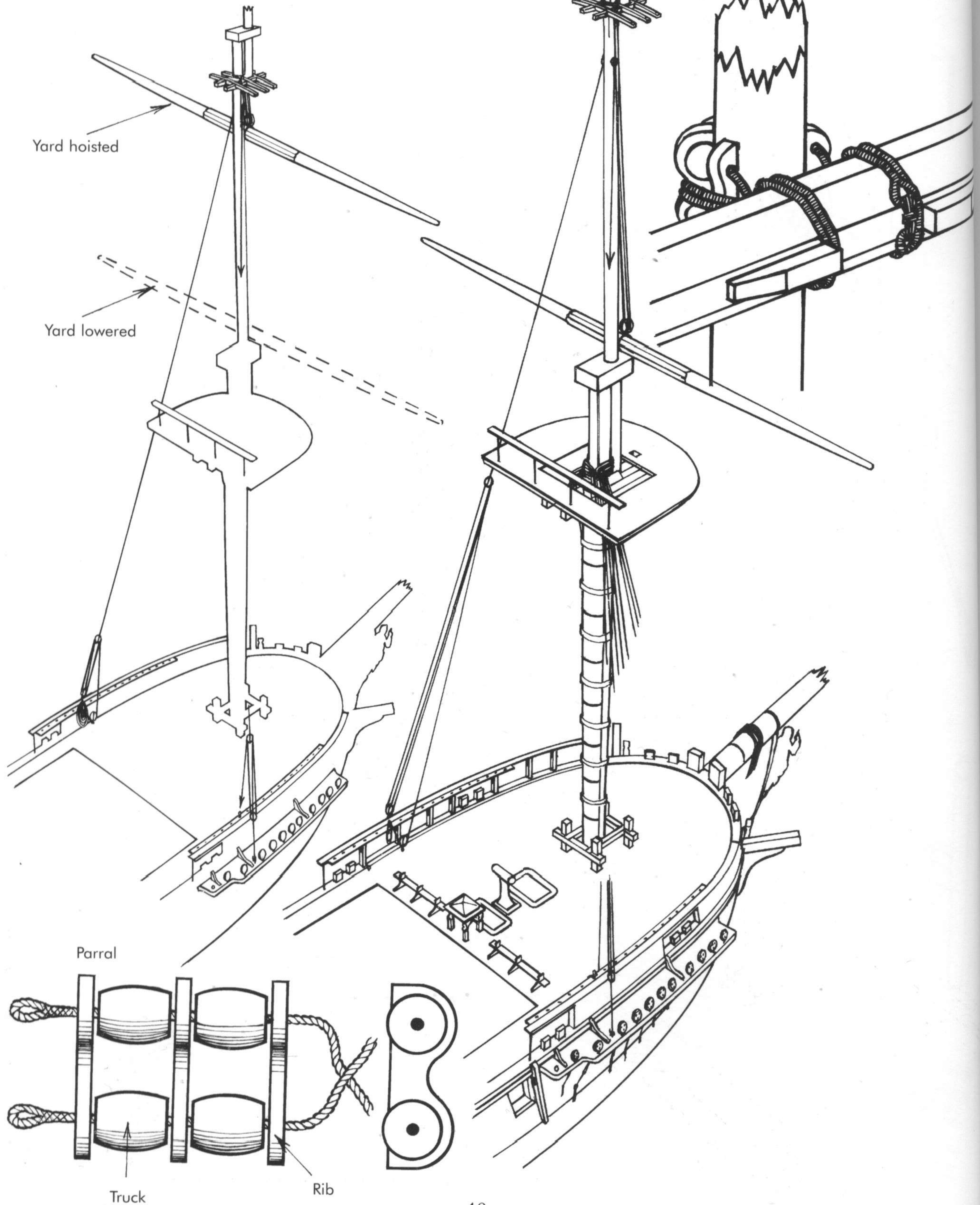

Fore Topgallant/ Royal Tye & Halliard

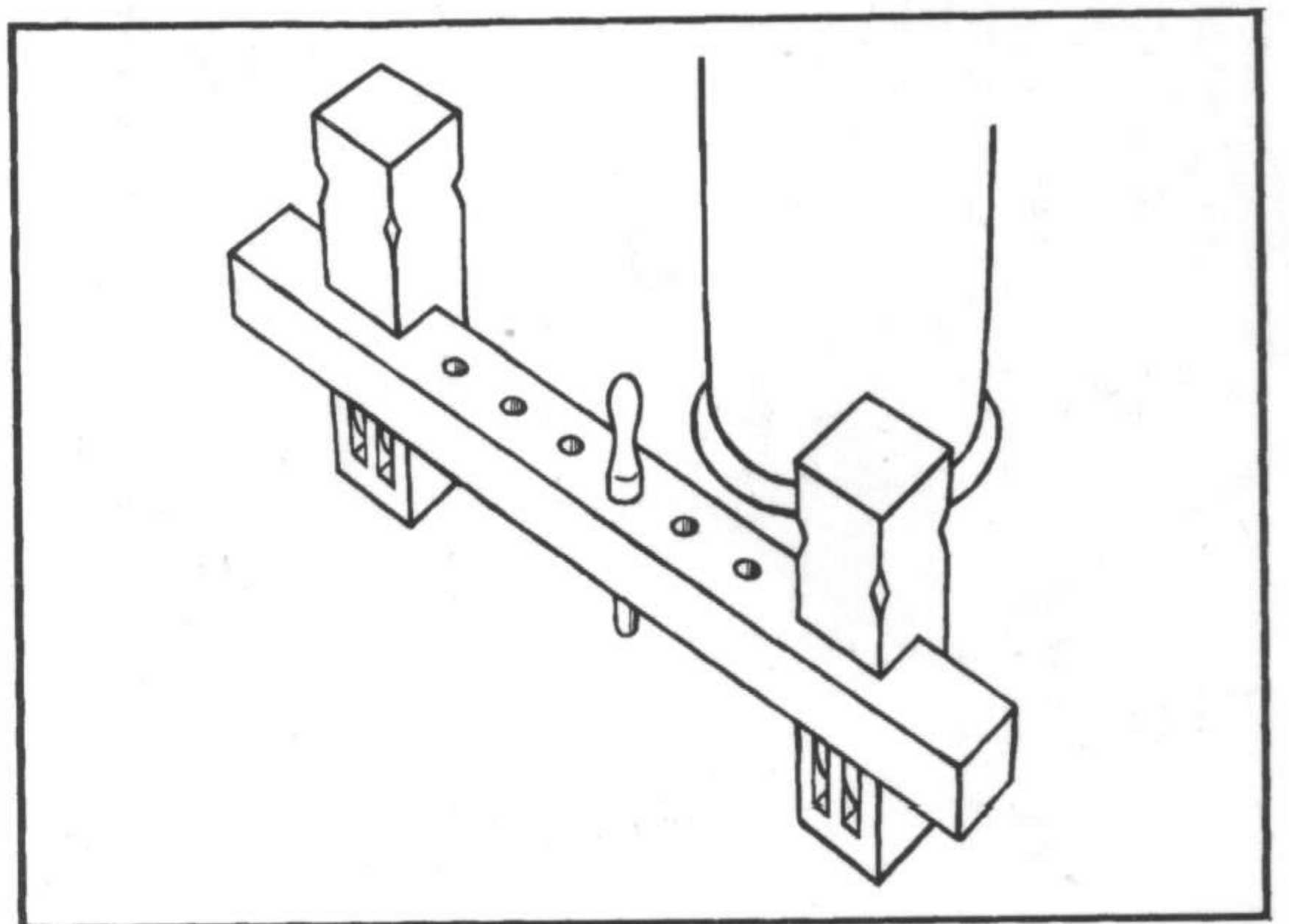
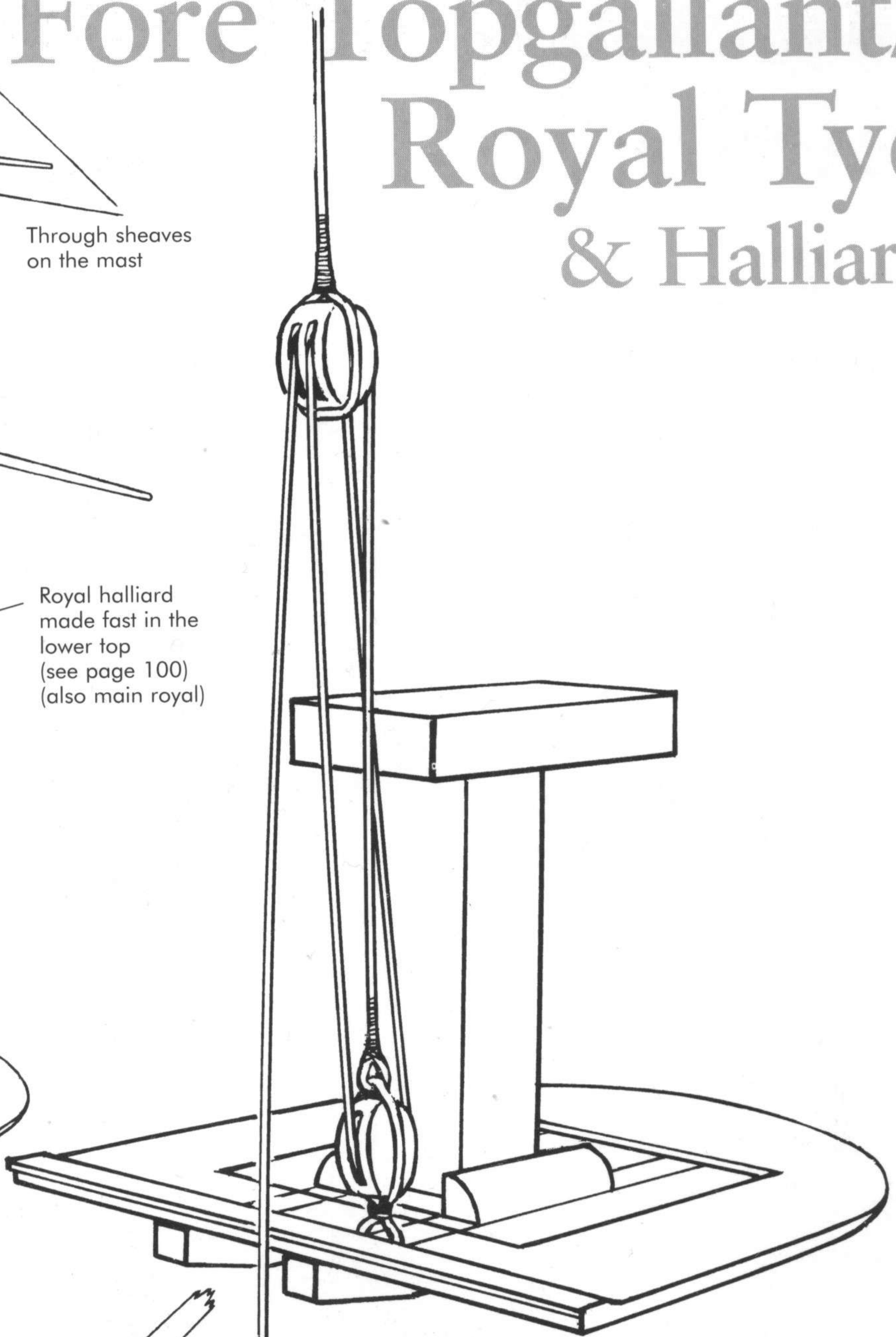
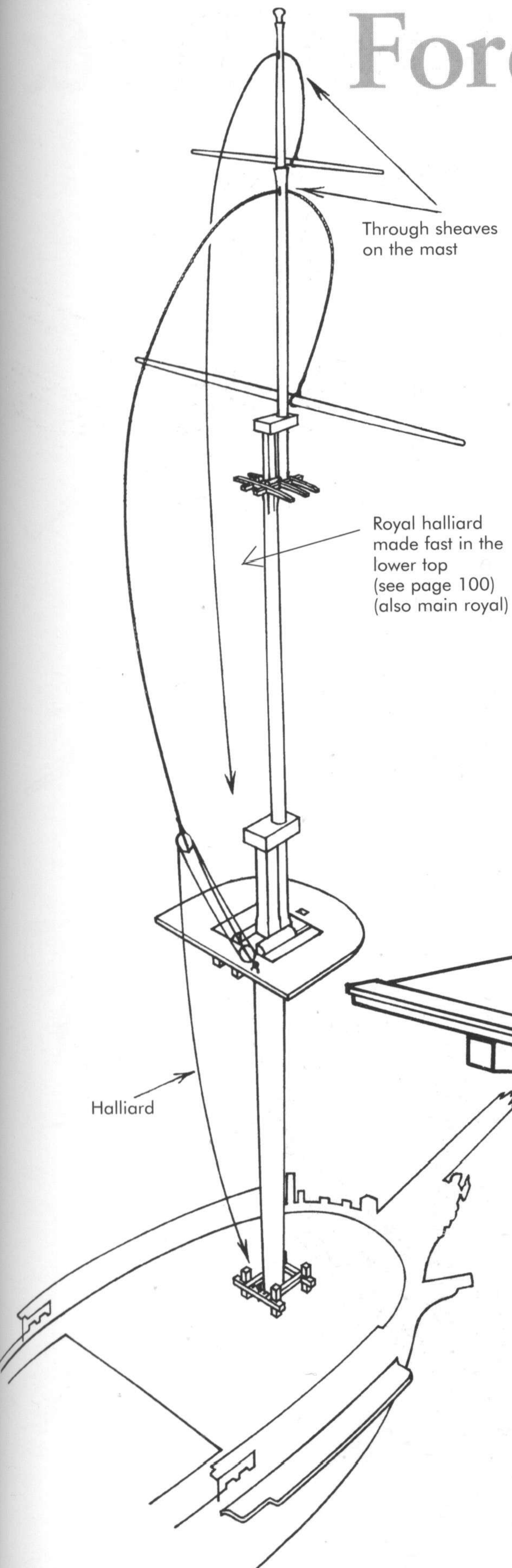

Fore Topsail, Topgallant & Royal Lifts

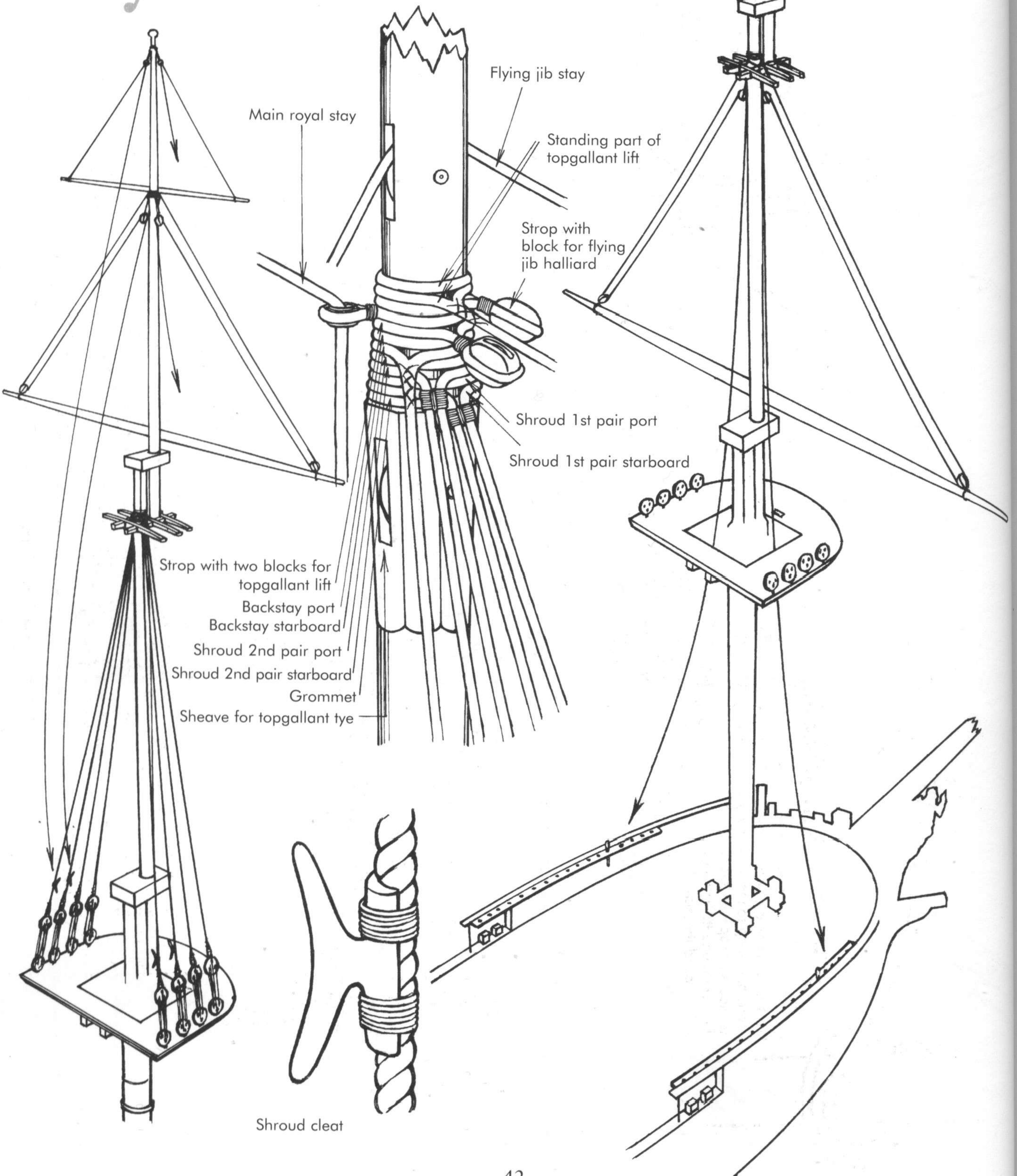

Main & Main Topsail Braces

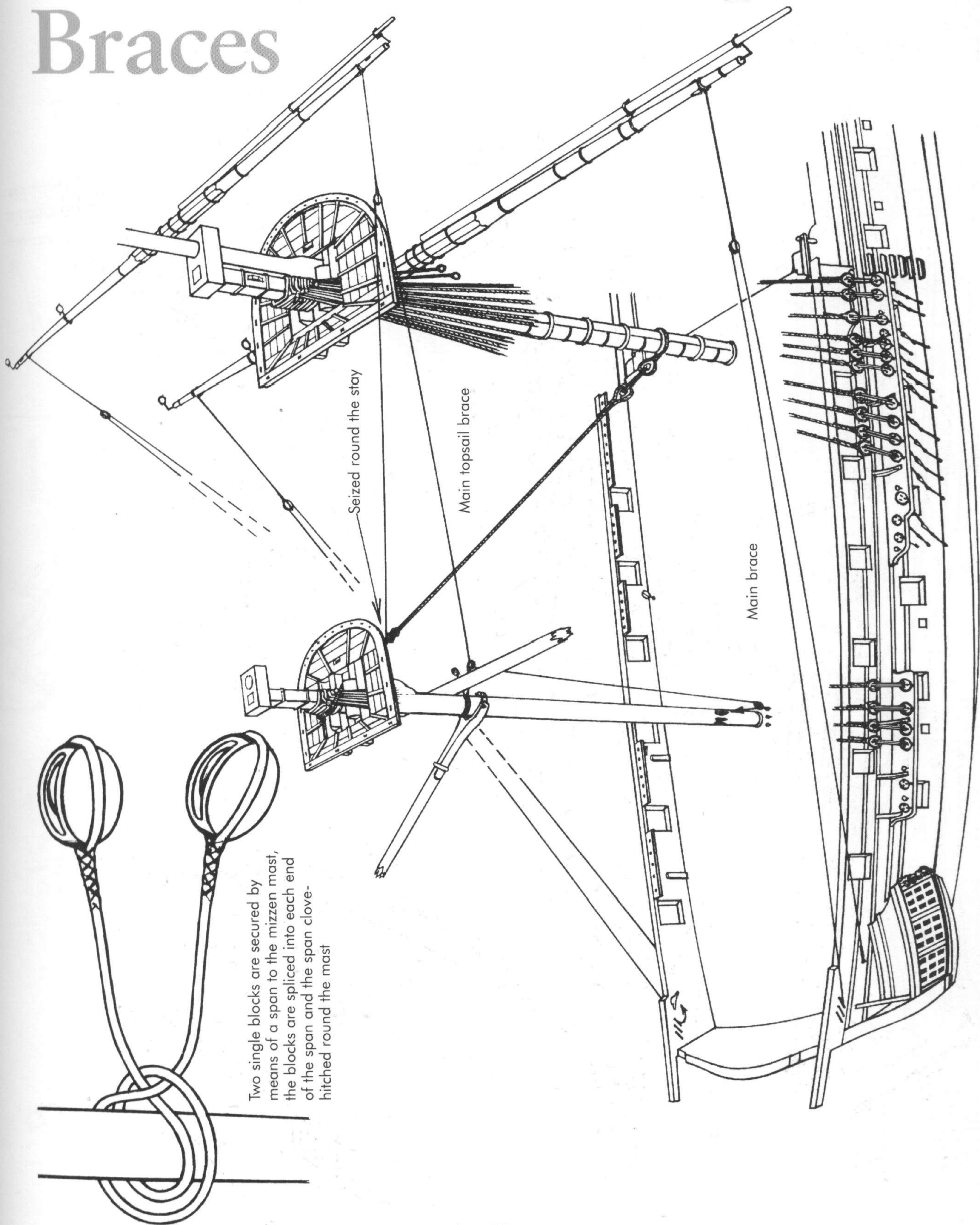

Fore & Fore Topsail Braces

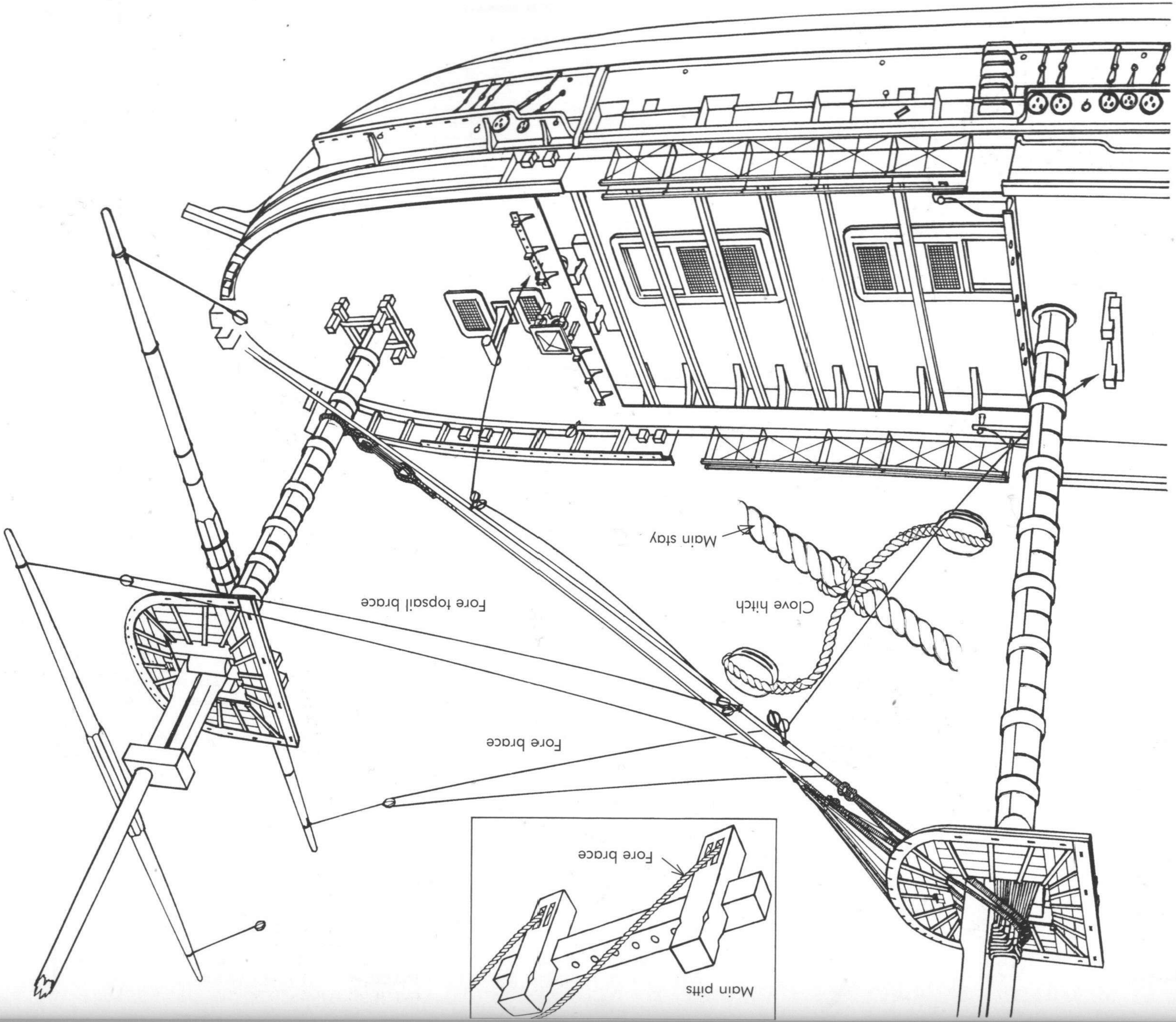

Fore & Main Topgallant Braces

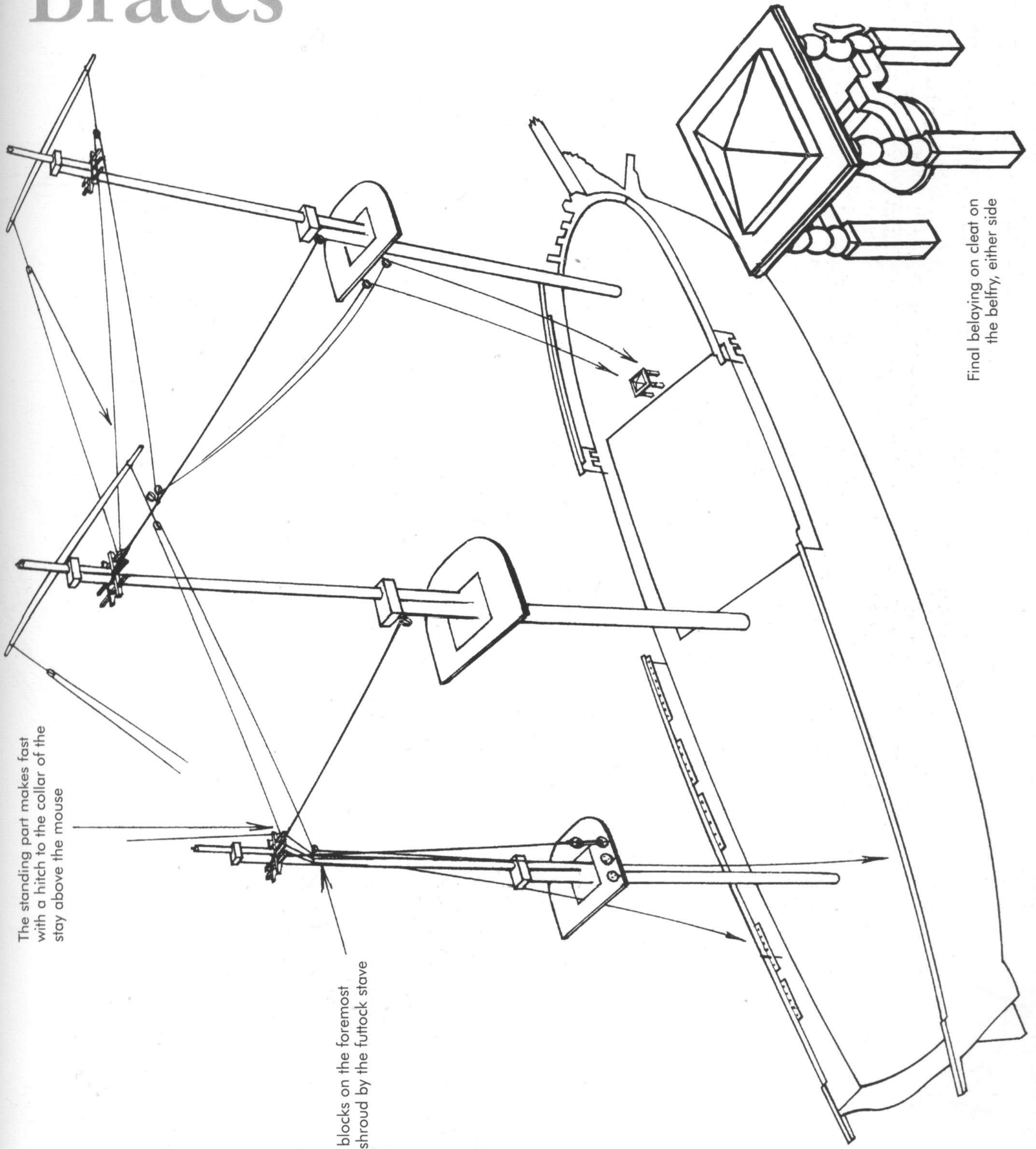

The standing part makes fast with a hitch to the collar of the stay above the mouse

Through blocks on the foremost topmast shroud by the futtock stave

Final belaying on cleat on the belfry, either side

Fore & Main Royal Braces

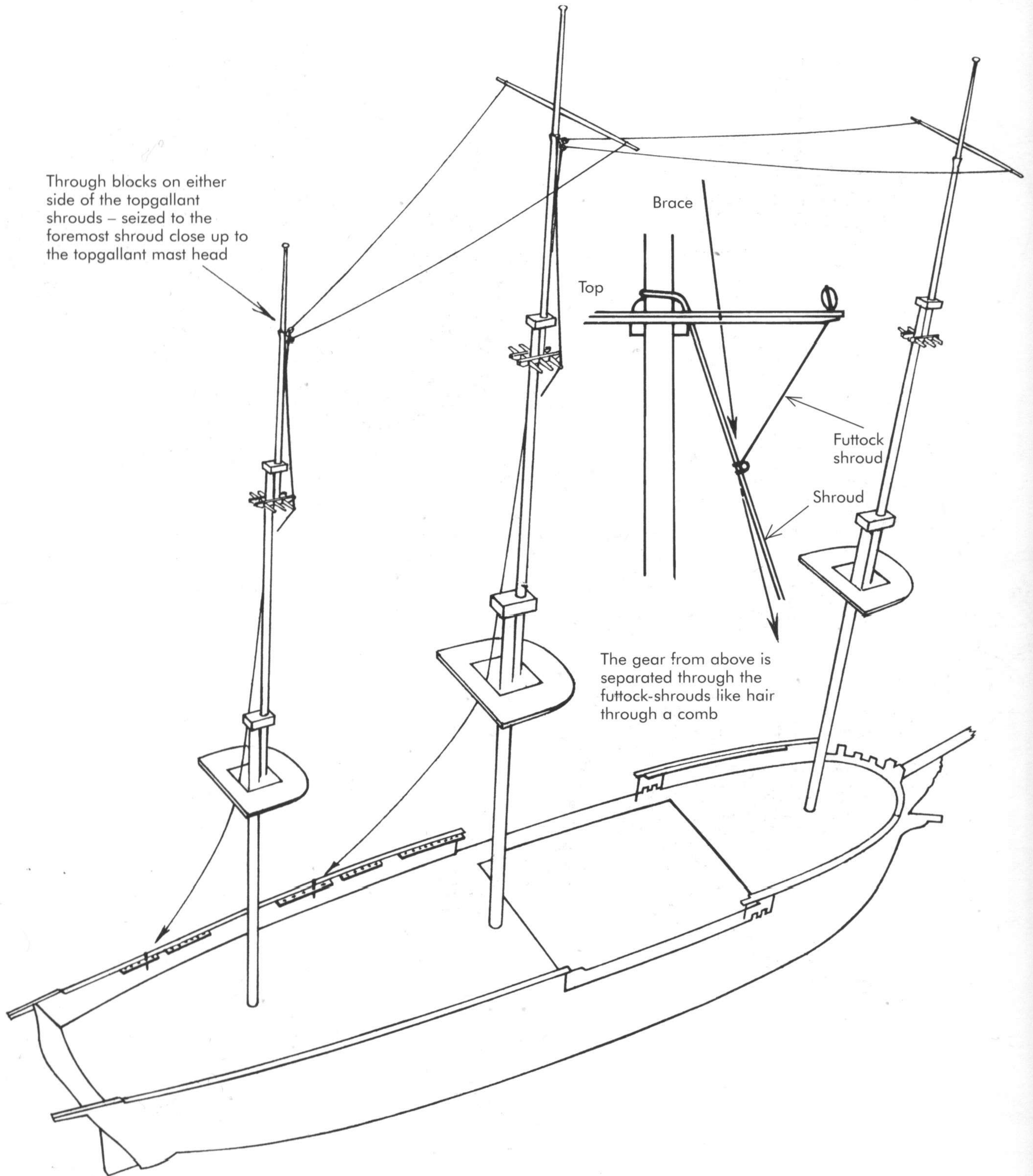

Spritsail & Spritsail Topsail Braces

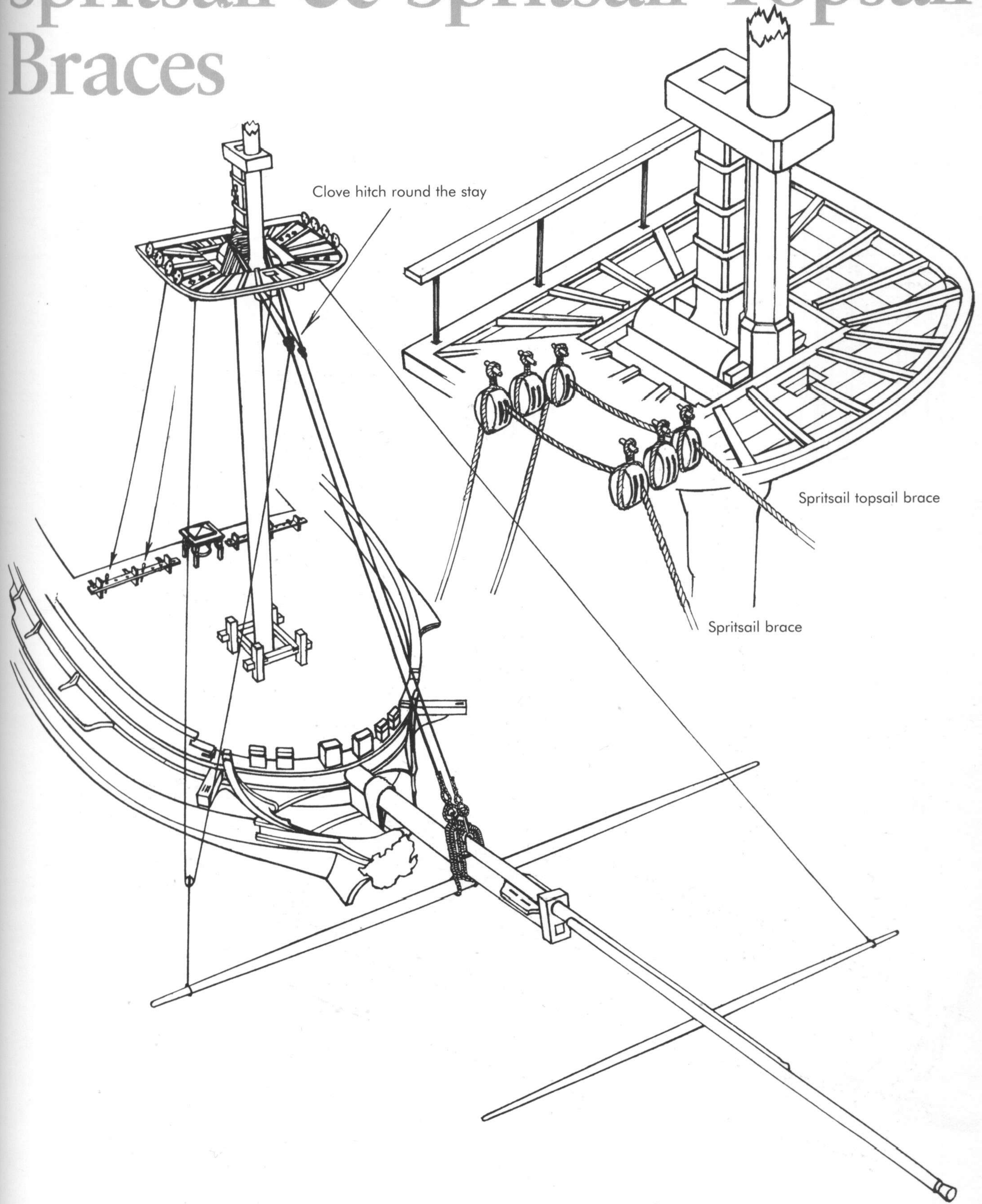

Fore Sheet, Tack & Clueline

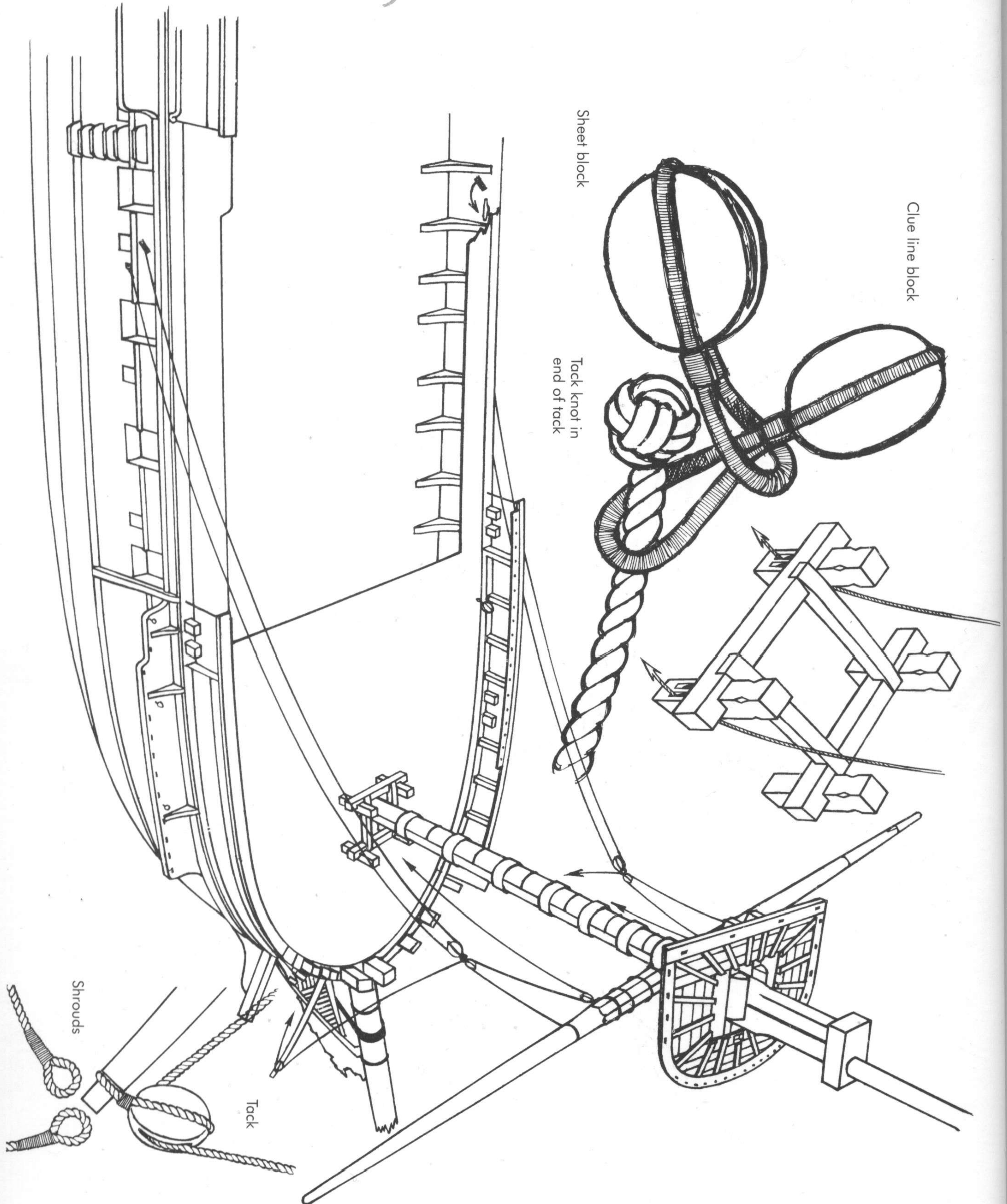

Fore Topsail Sheet & Clueline

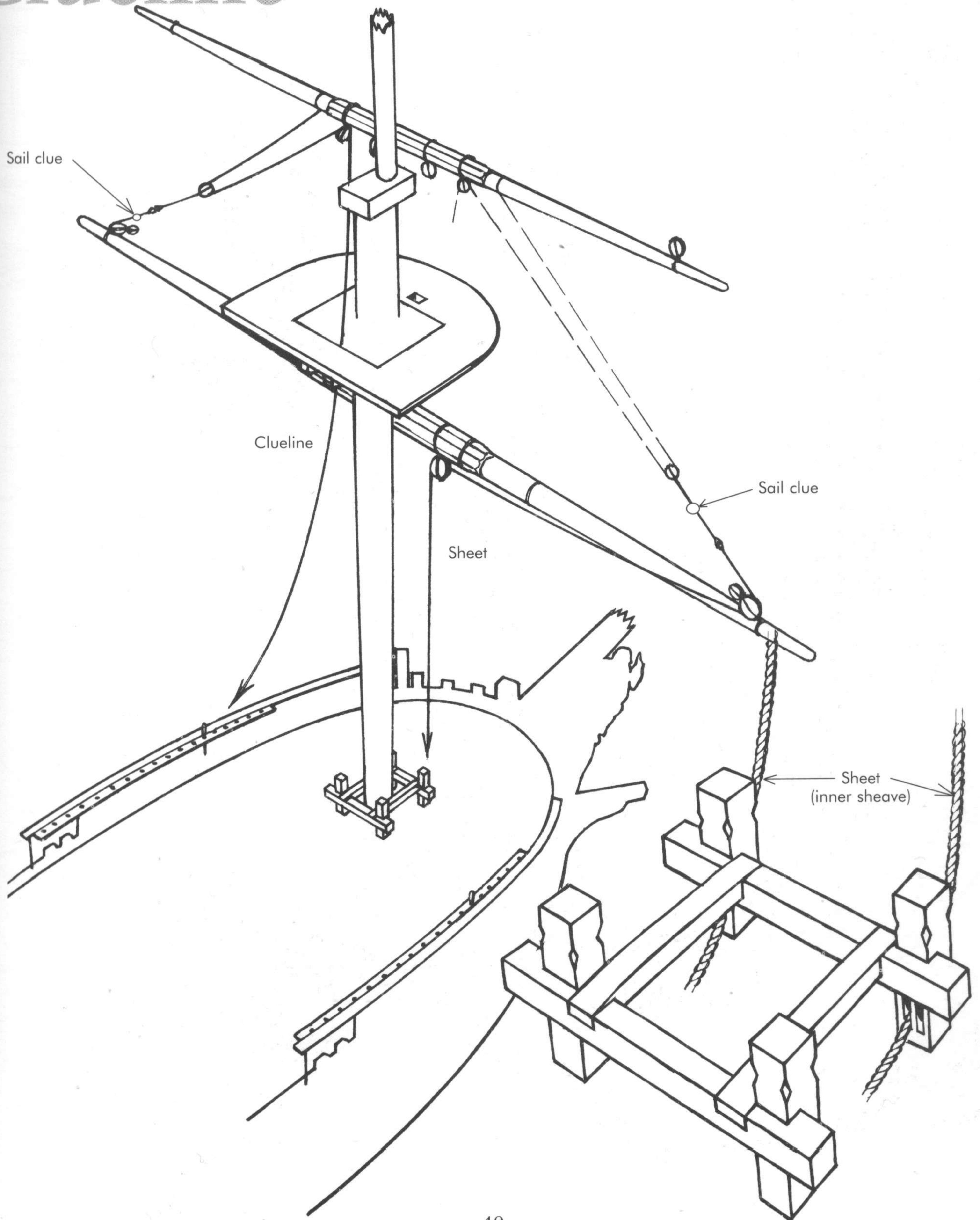

Fore Topgallant & Royal Sheet, Fore Topgallant Clueline

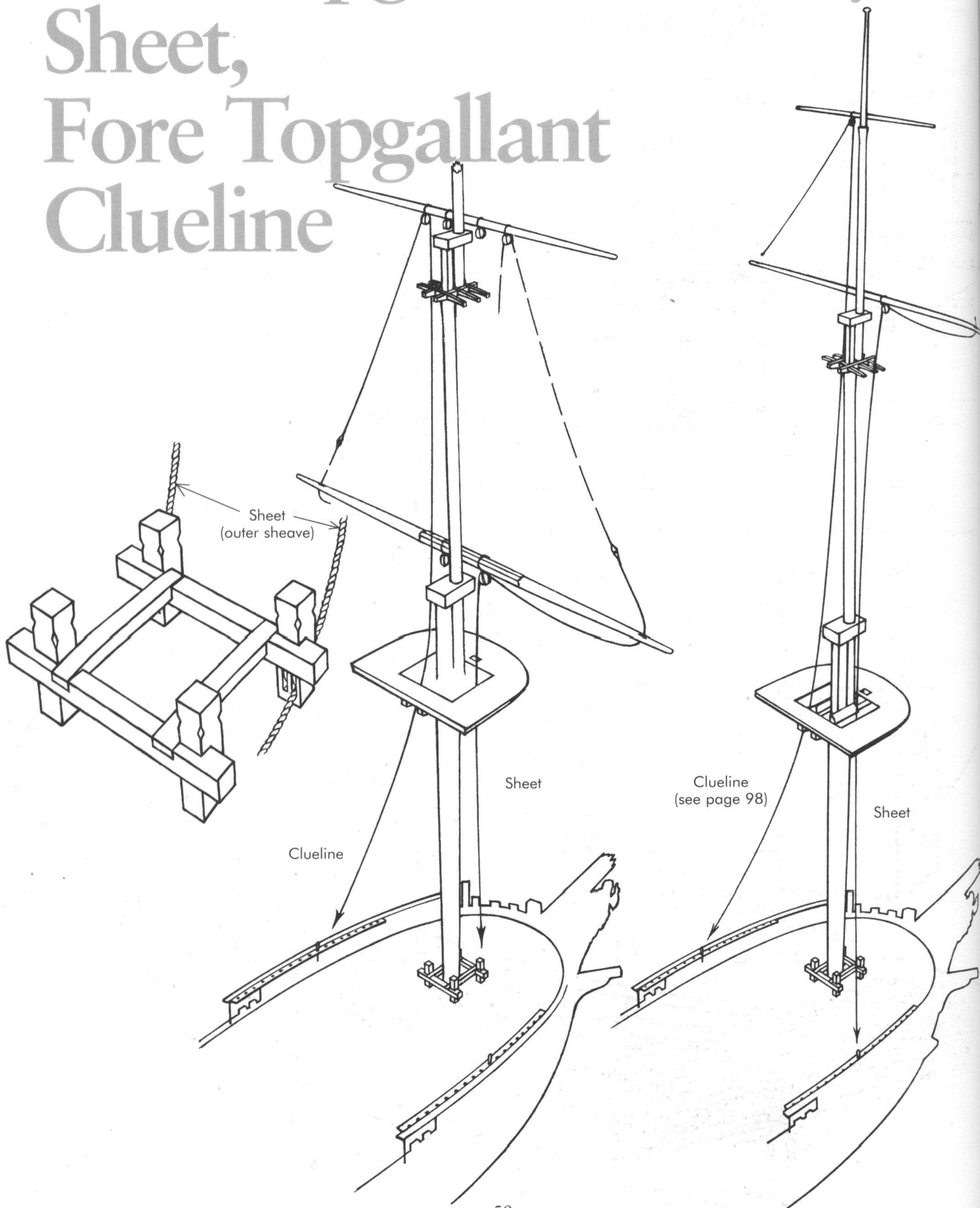

Main Sheet, Clueline & Tack

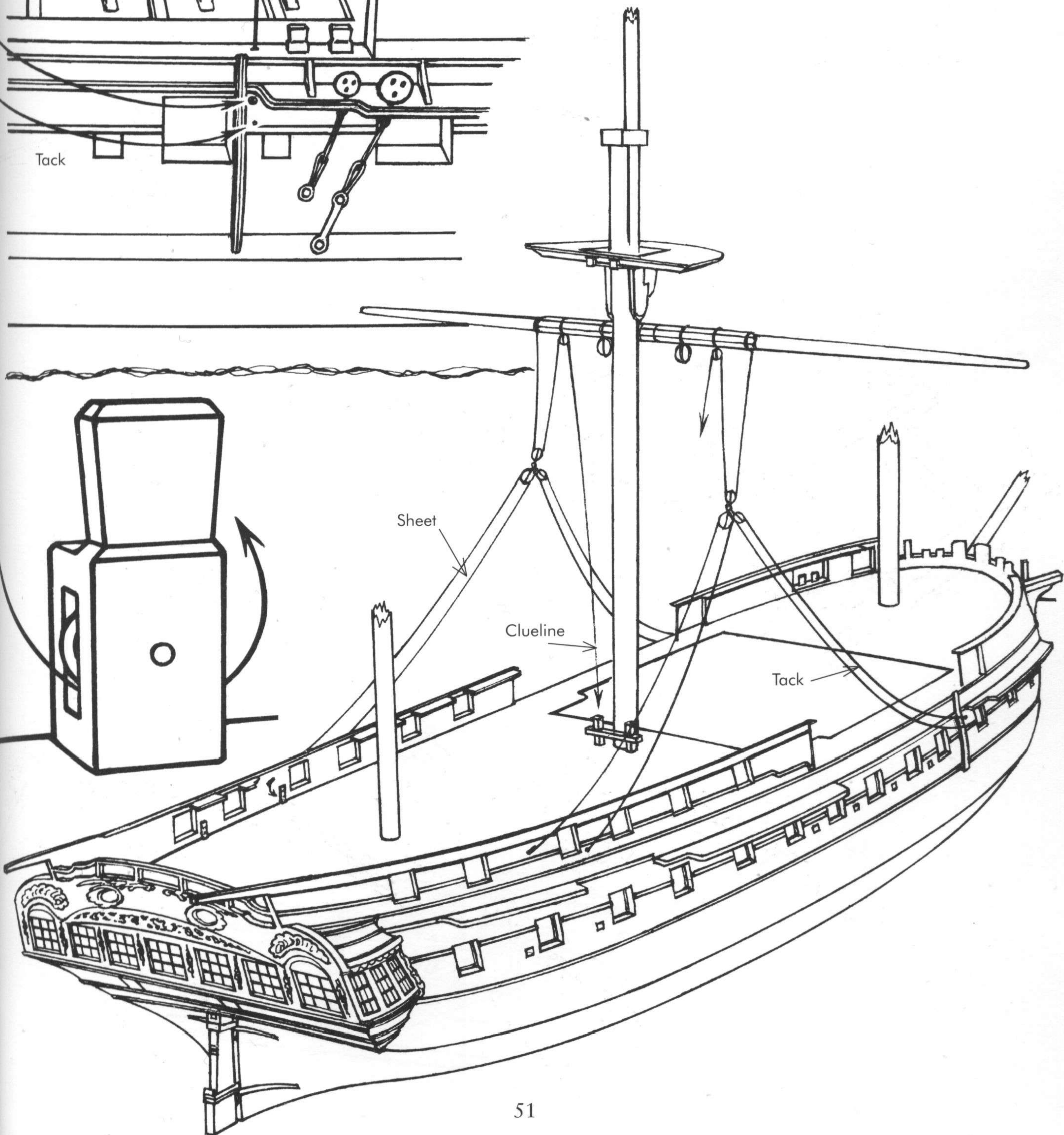
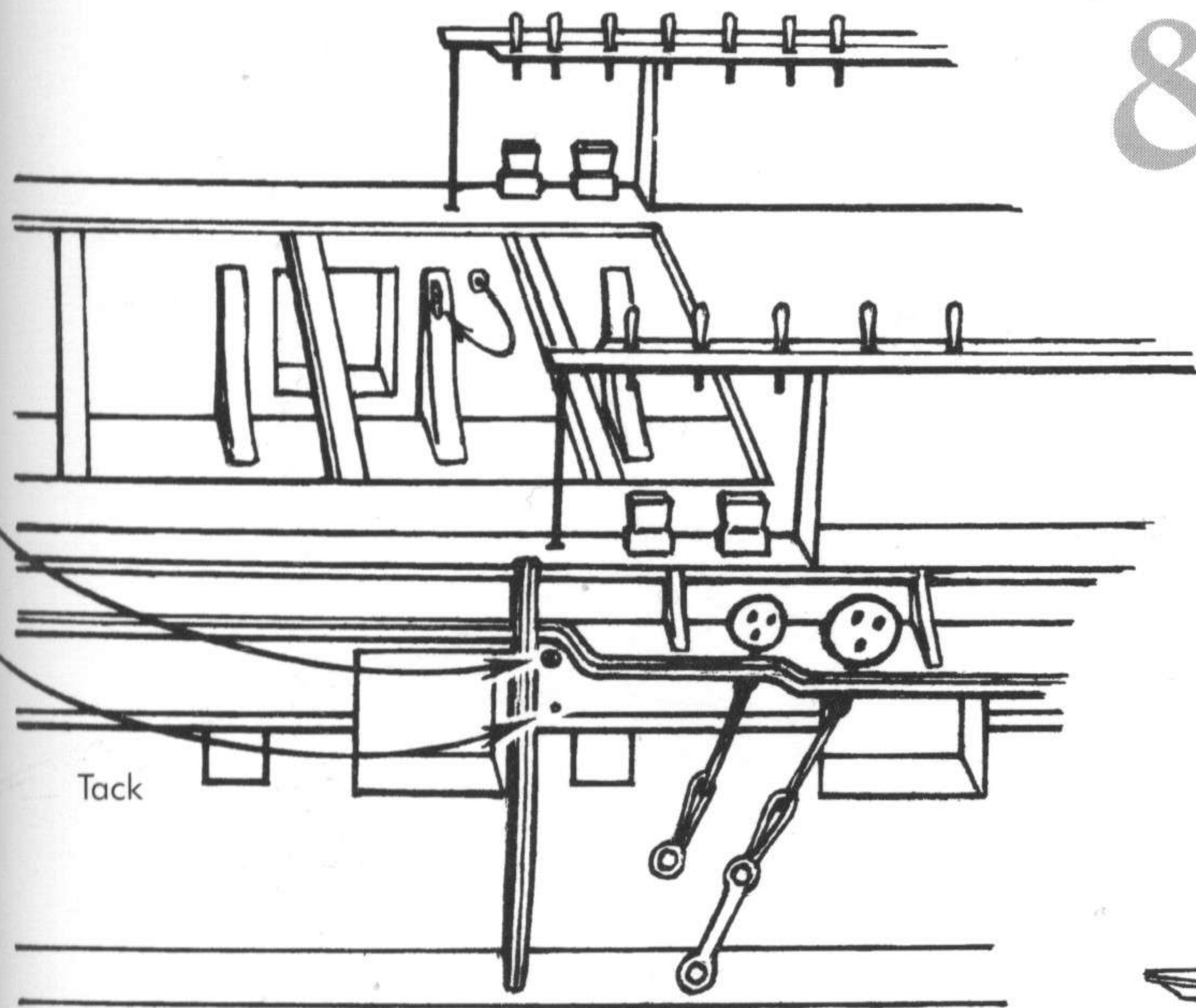

Main Topsail Sheet

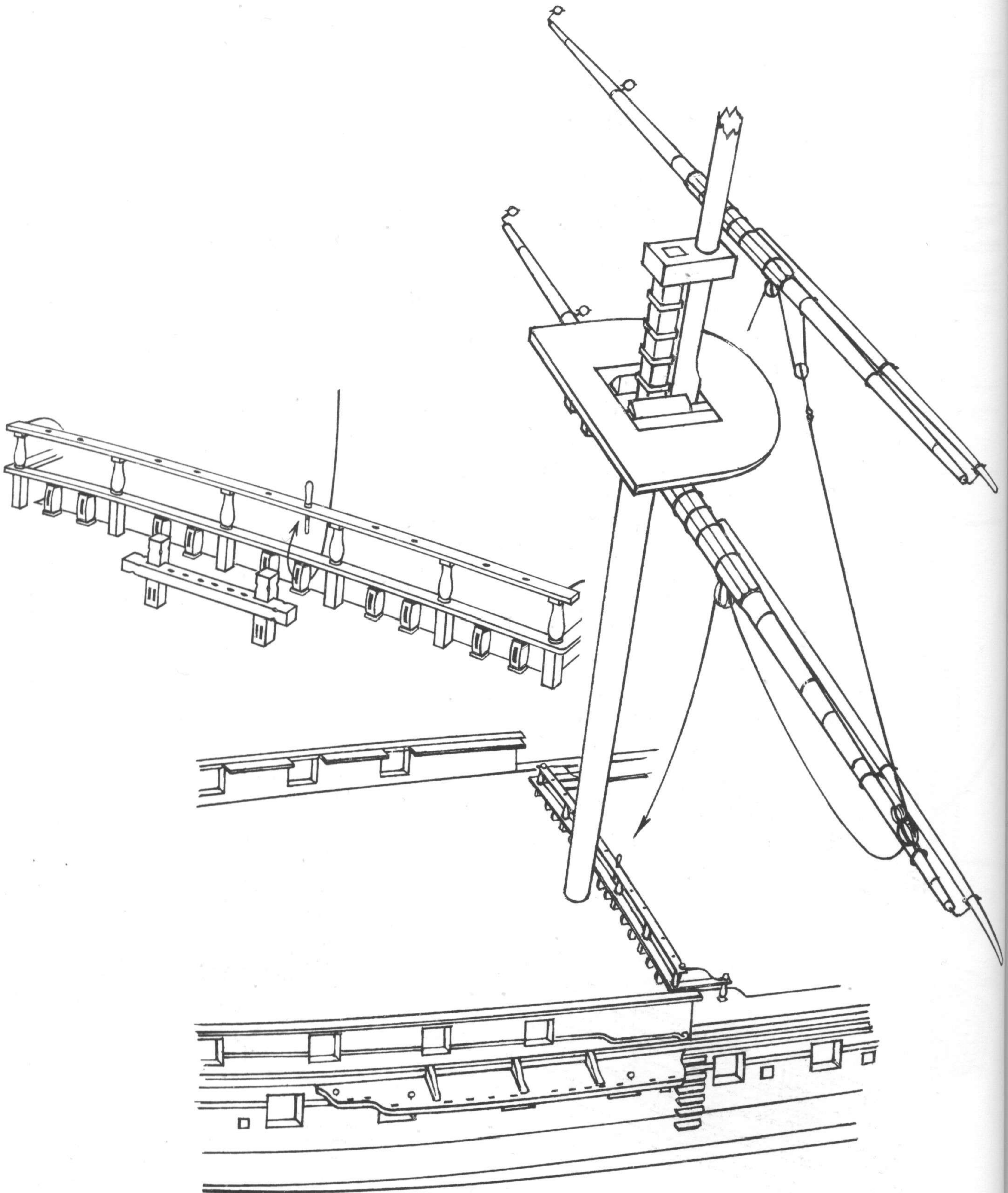

Main Topsail Lift

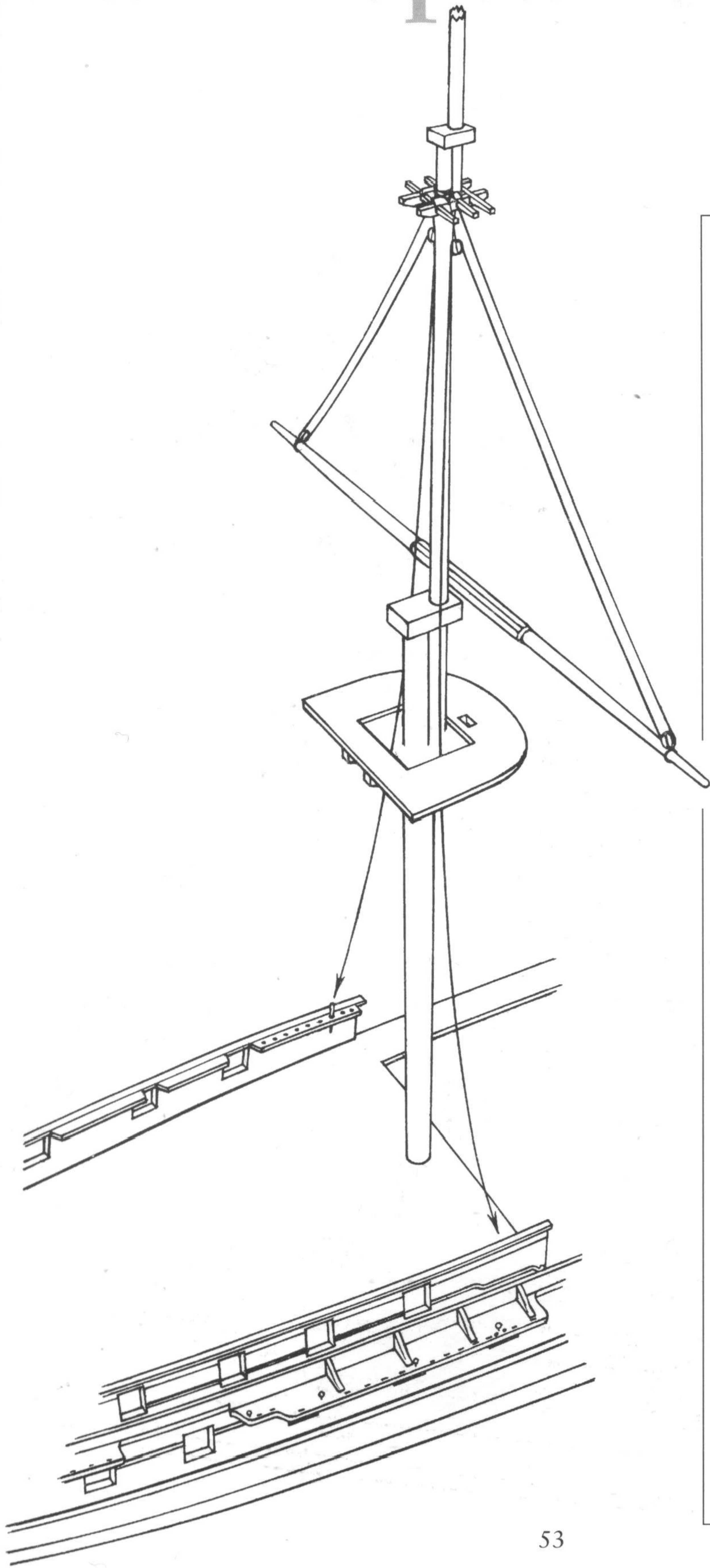

Topgallant & Royal Lifts

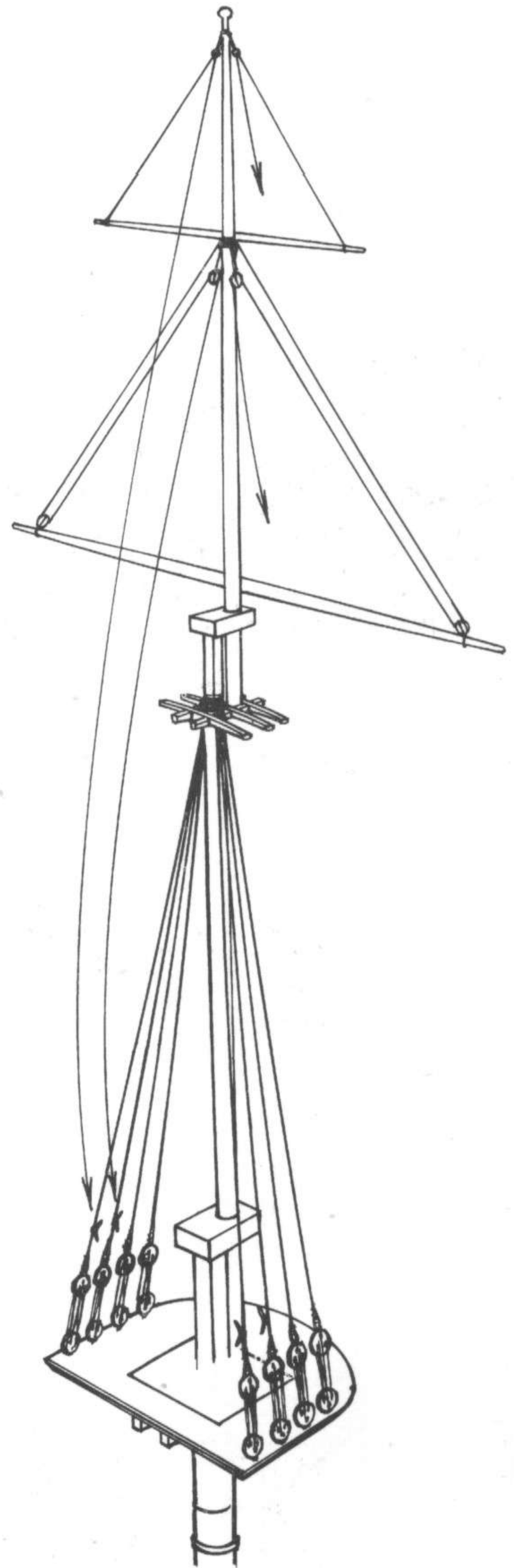

These were rigged in the same way as those on the fore topgallant and royal yard. See page 41.

Main Topsail Clueline

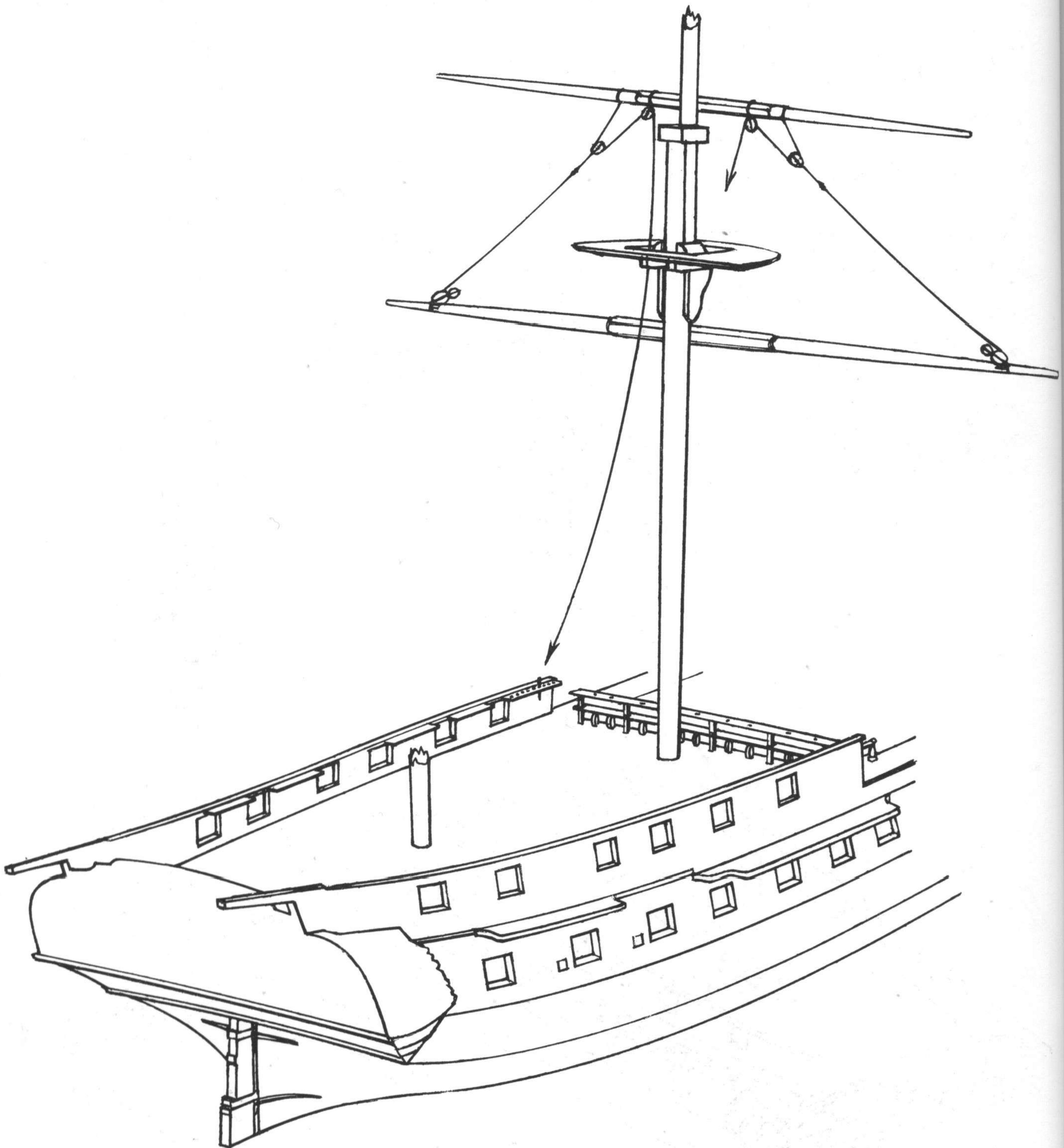

Main Topgallant Sheet & Clueline, Main Royal Sheet

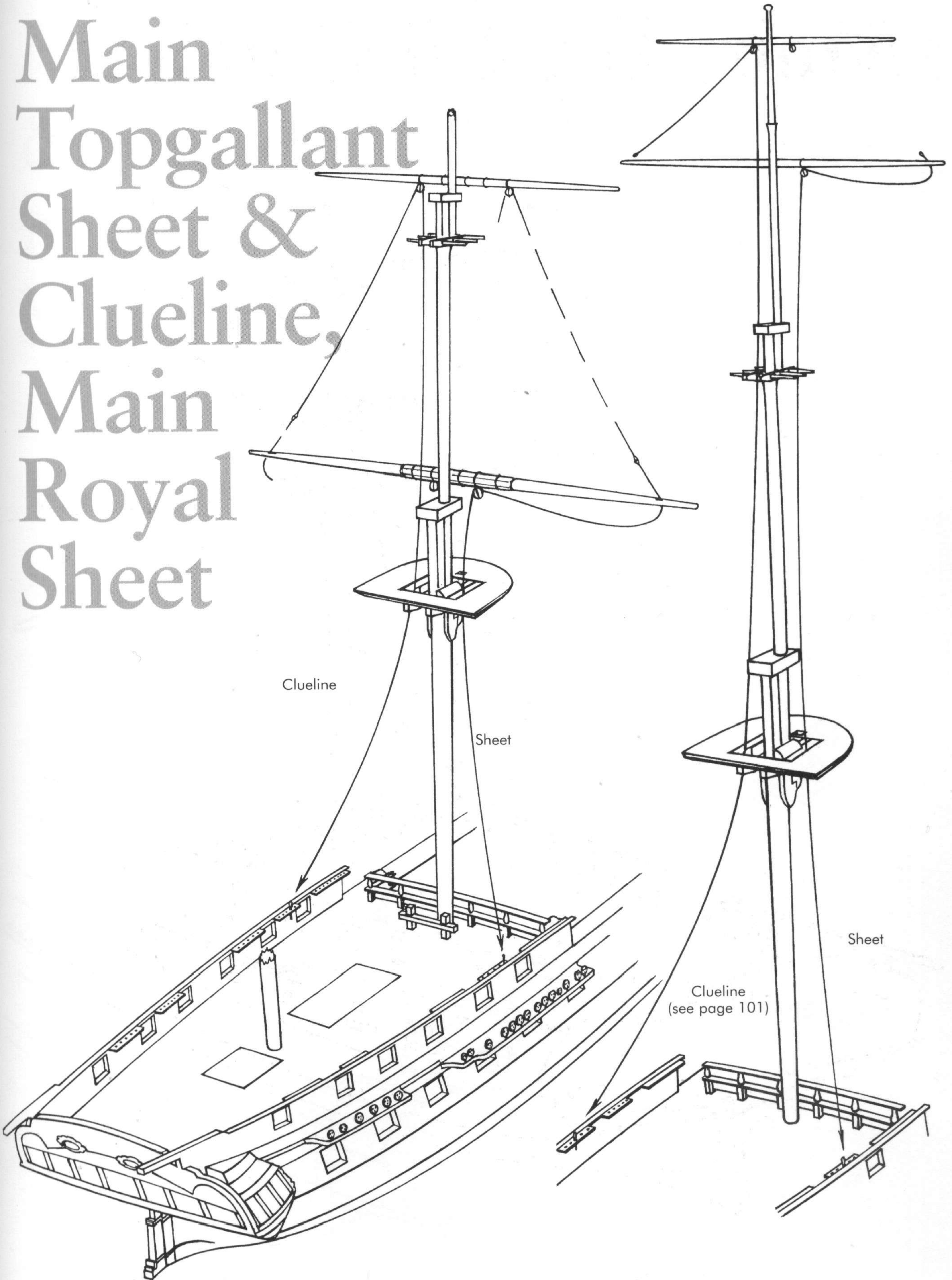

Mizzen Topsail Sheet & Clueline

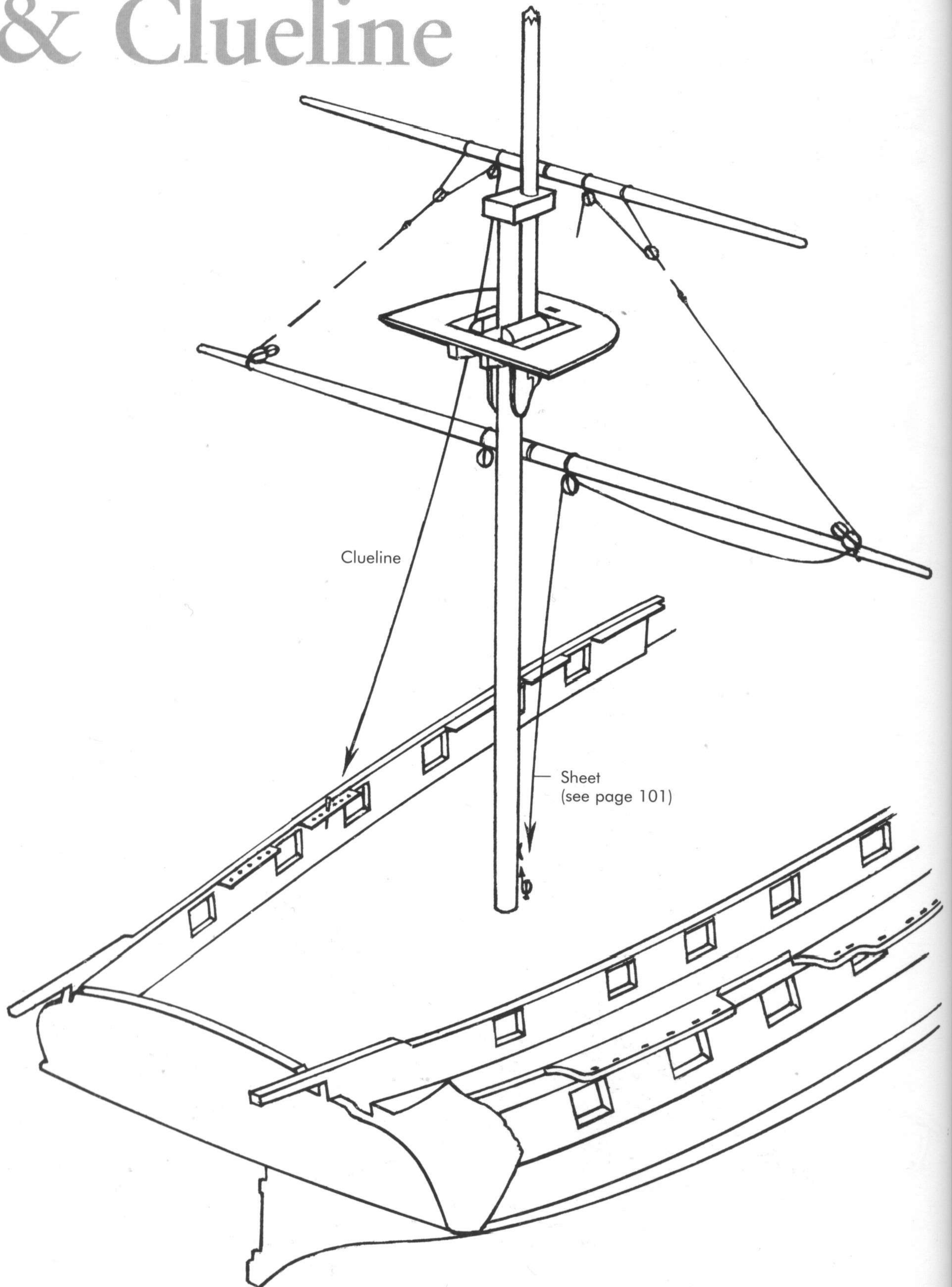

Mizzen Topgallant Sheet & Clueline, Mizzen Royal Sheet

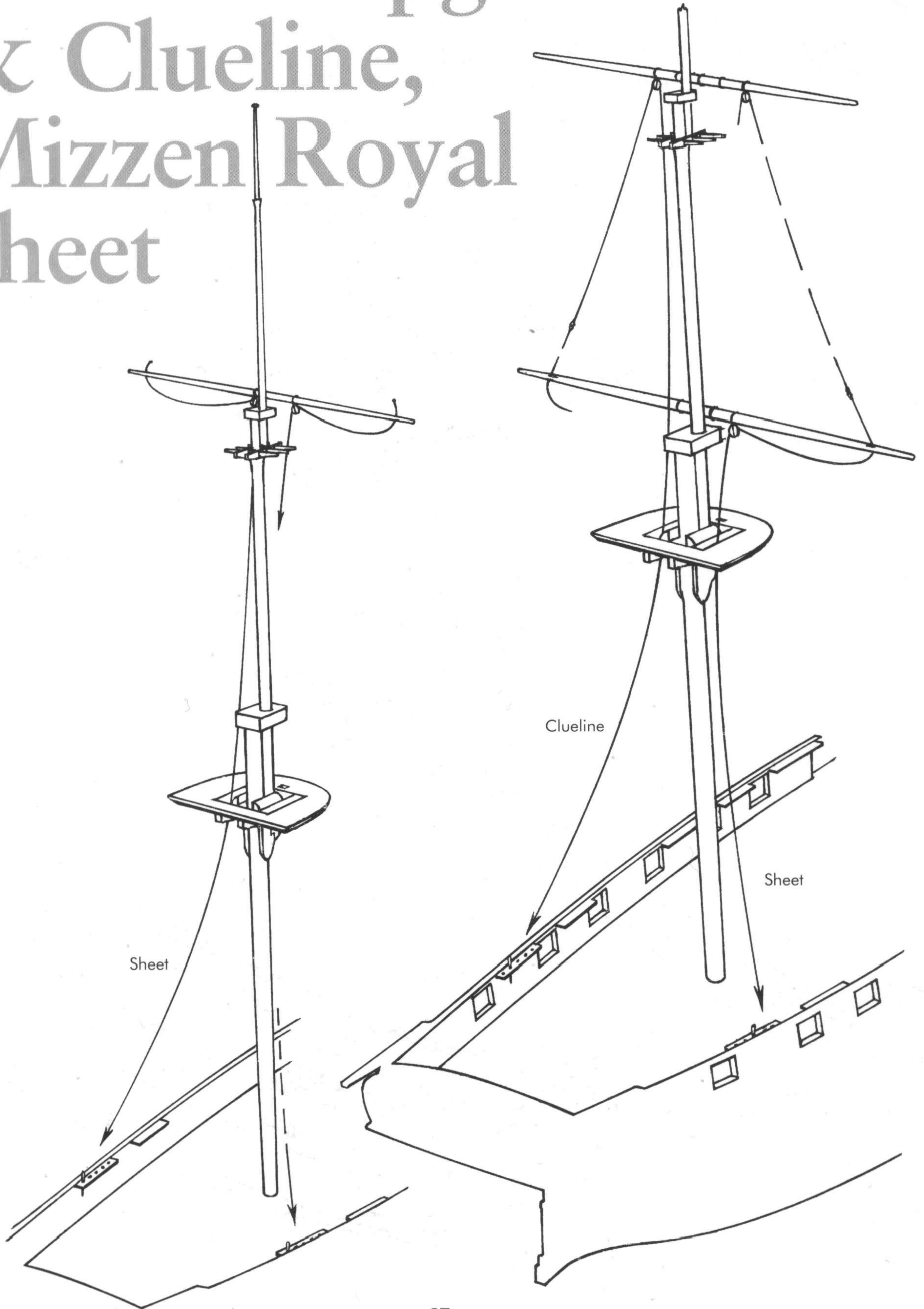

Jibboom & Flying Jibboom Guys

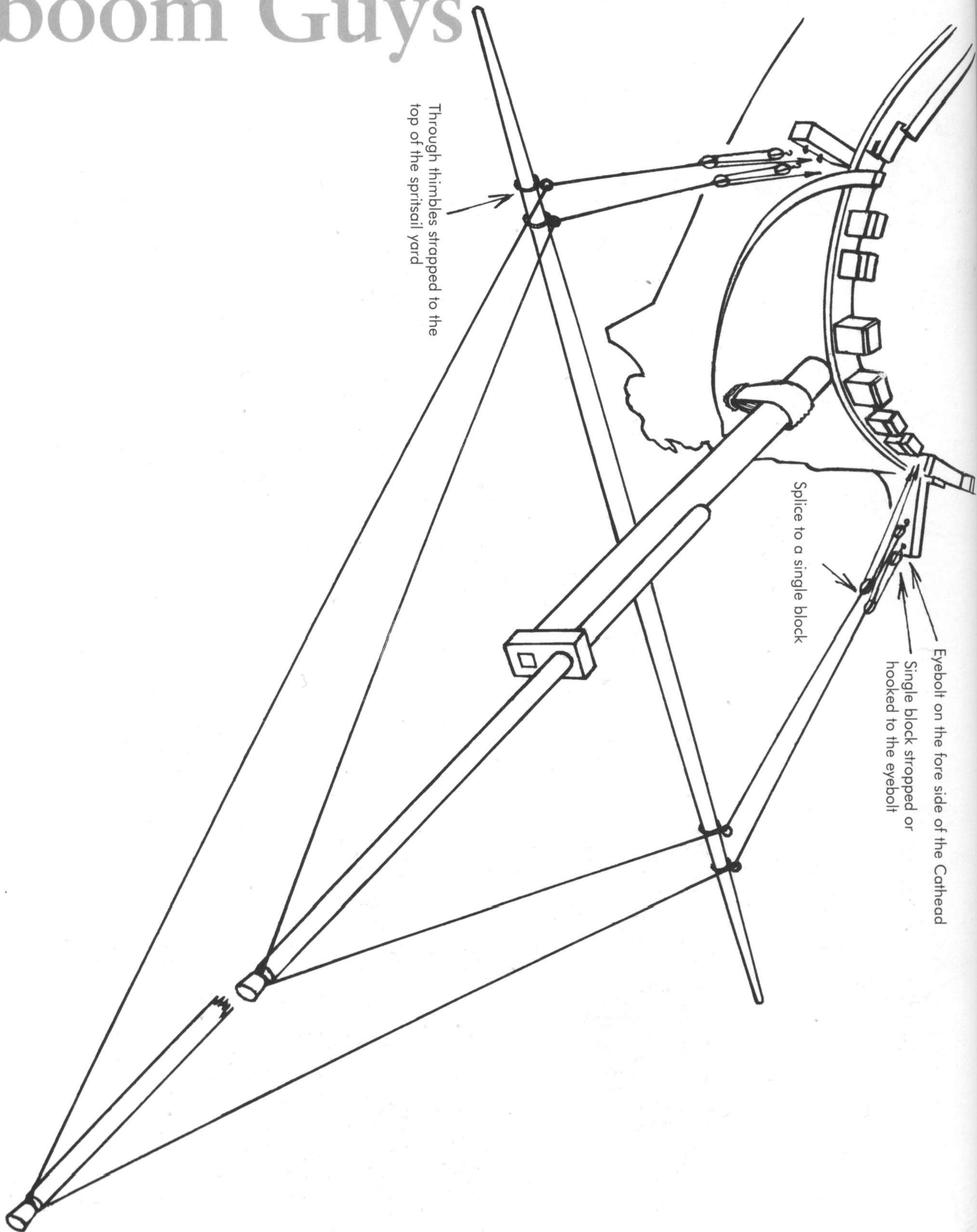

Spritsail Sling, Spritsail Yard & Spritsail Topsail Yard Halliards

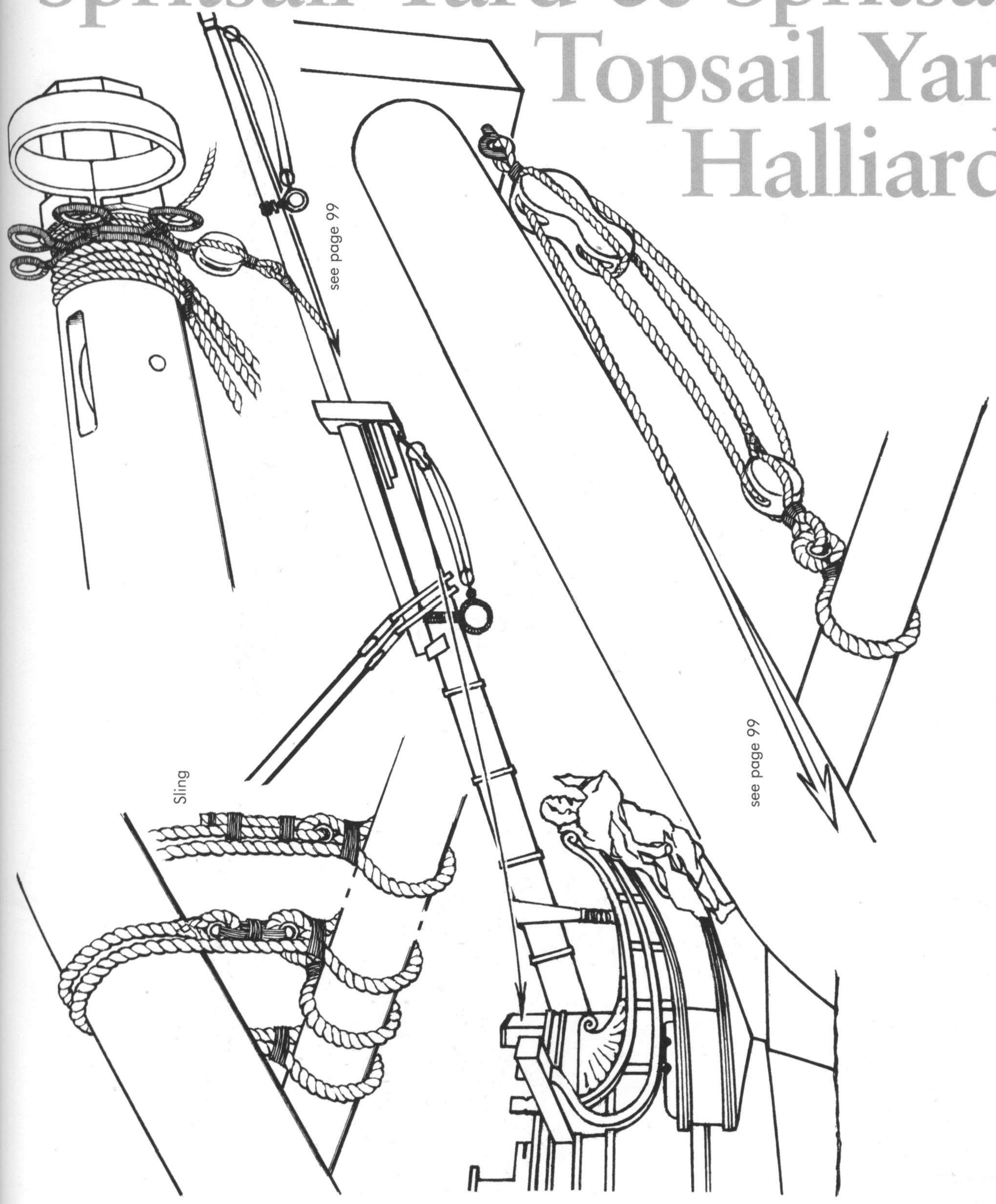

Royal Stay

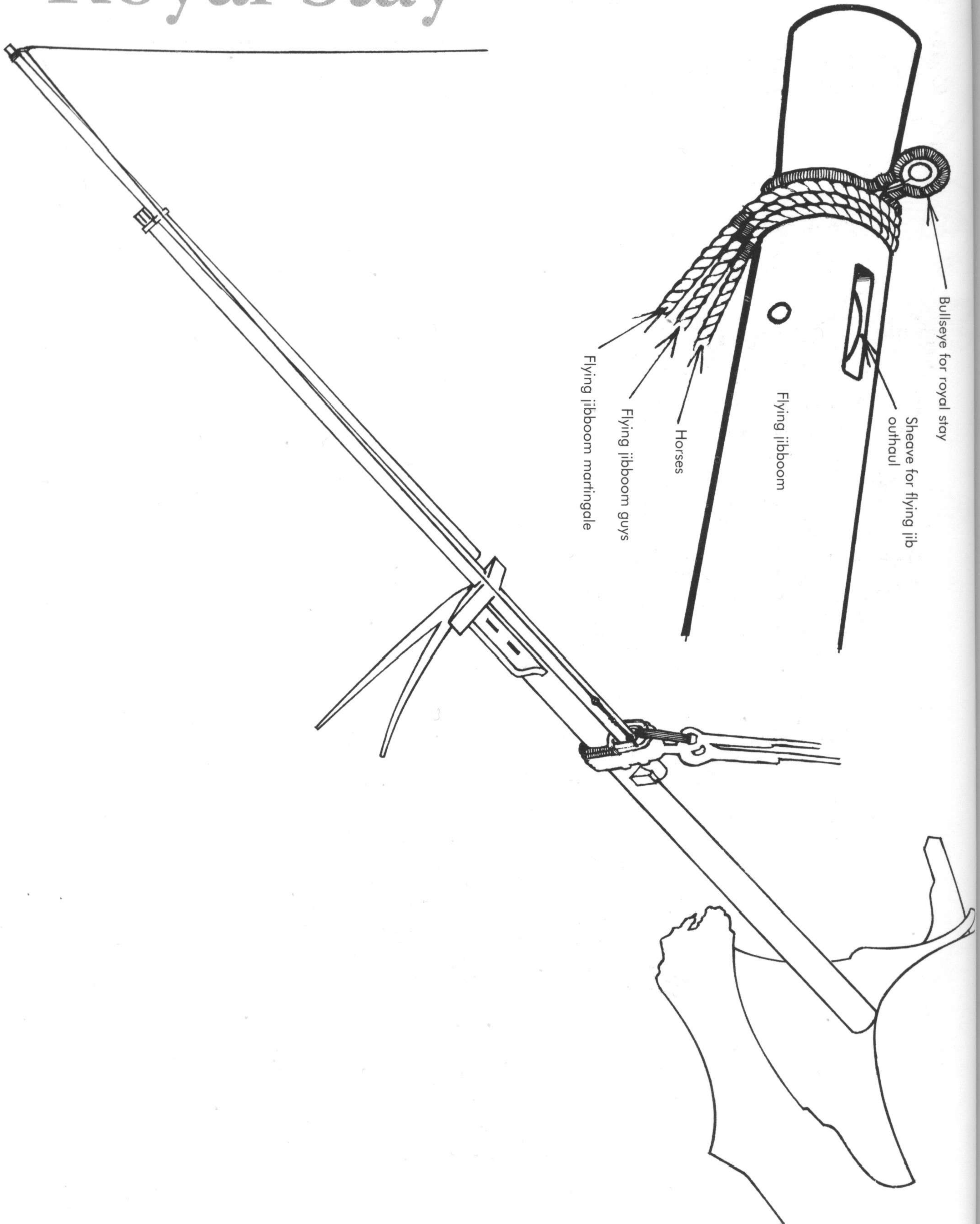

Fore Topgallant Stay & Bumpkin Shrouds

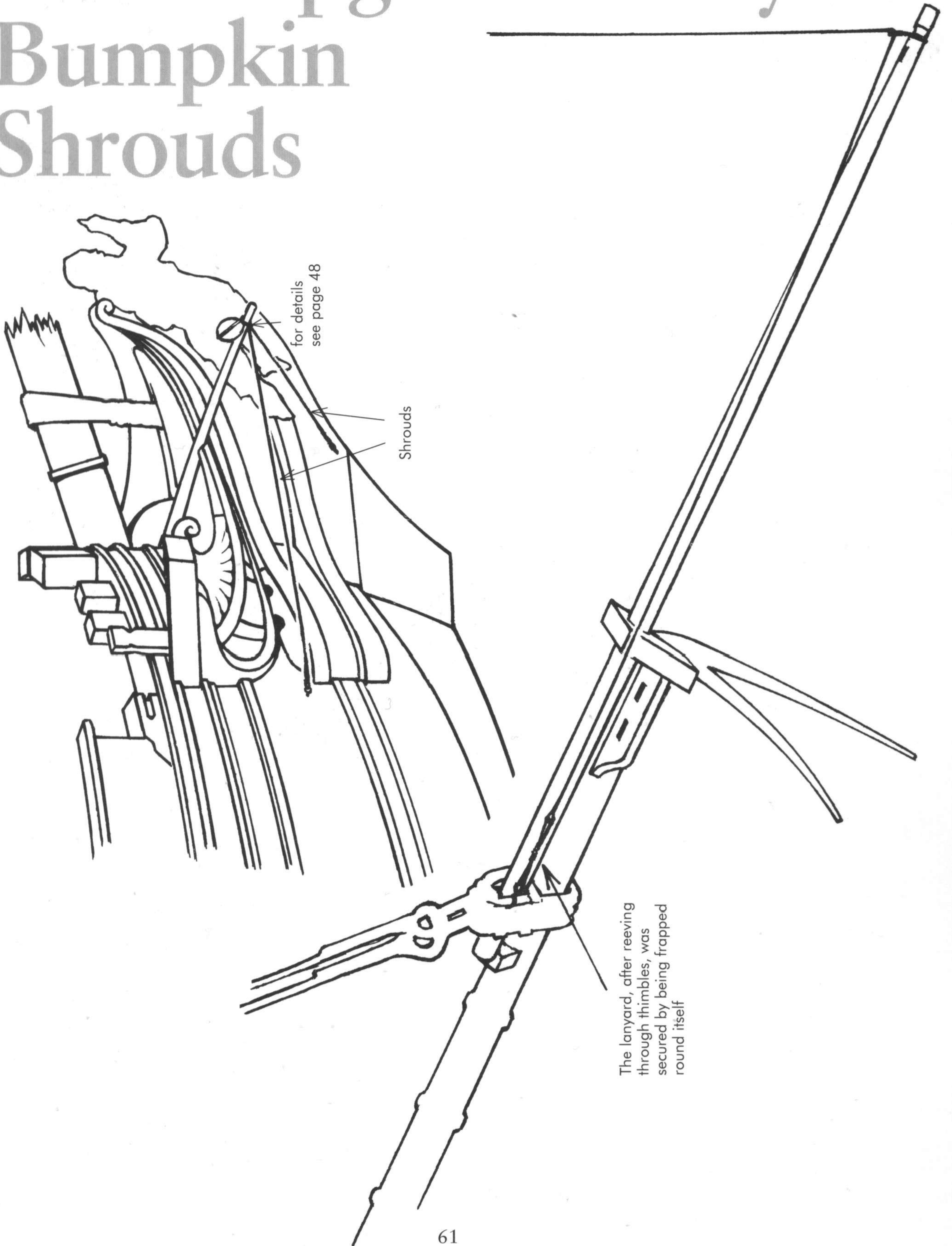

Jib Outhaul

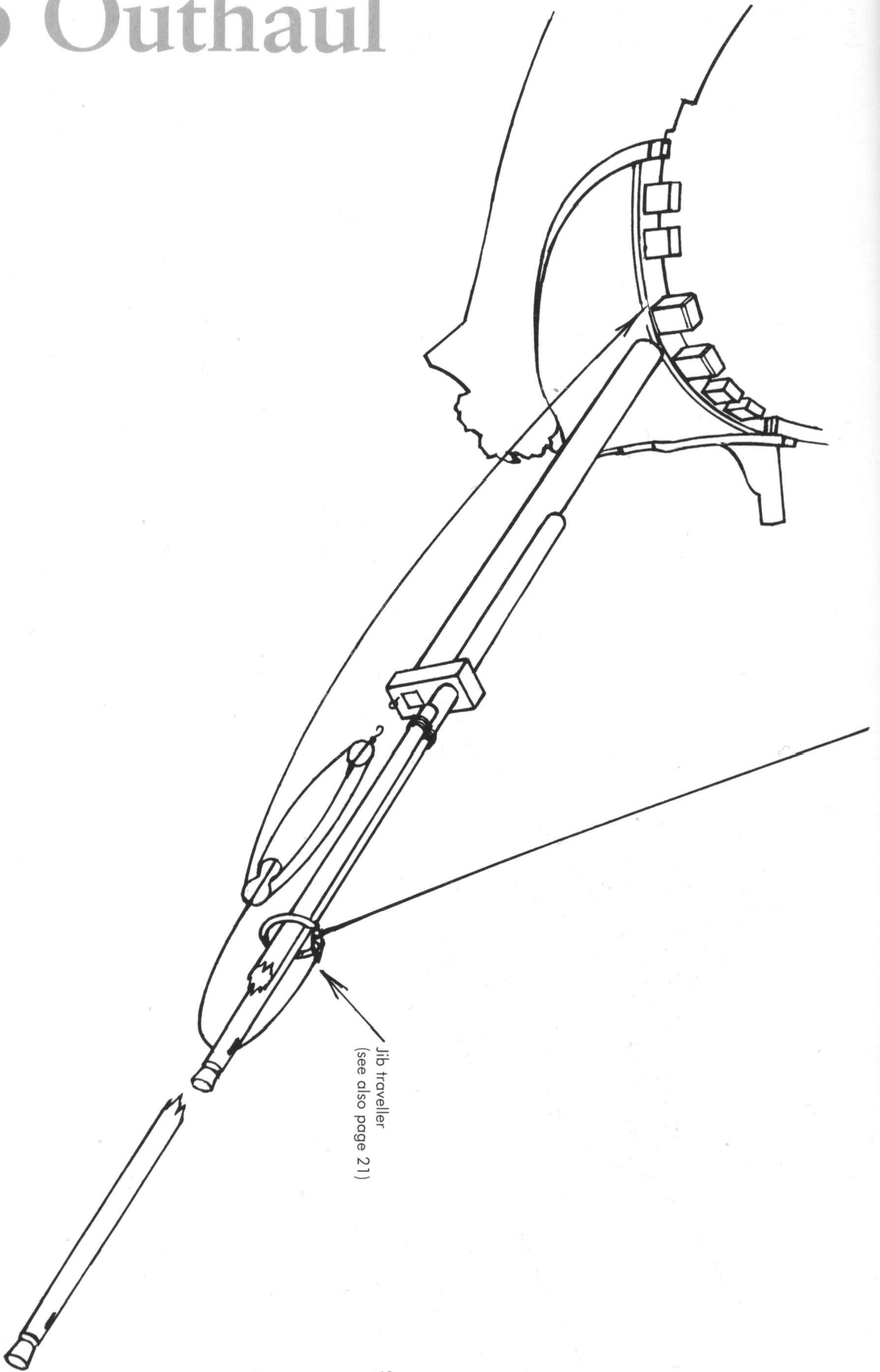

Flying Jib Outhaul

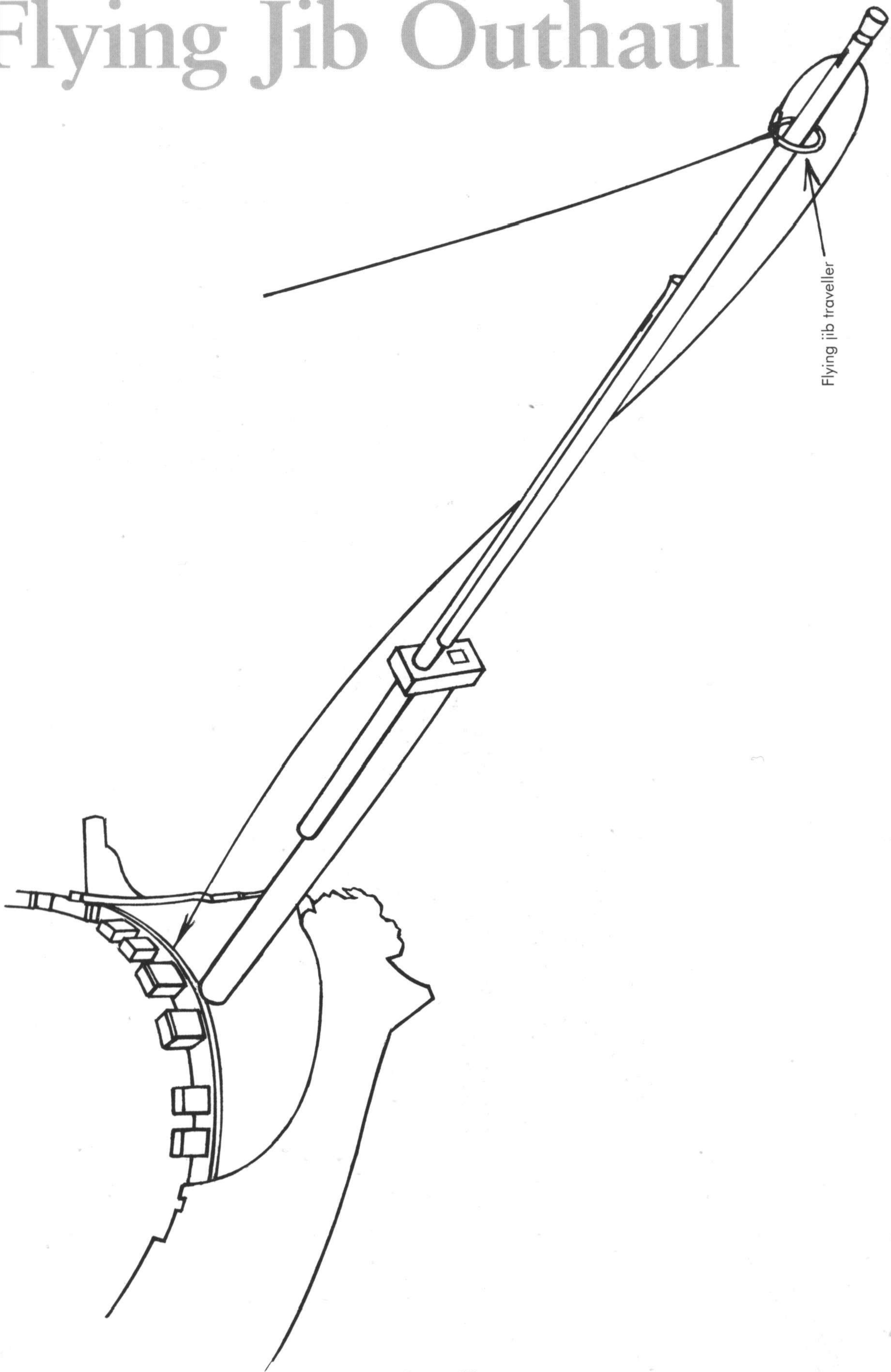

Spritsail Lift, Spritsail Topsail Clueline & Sheet

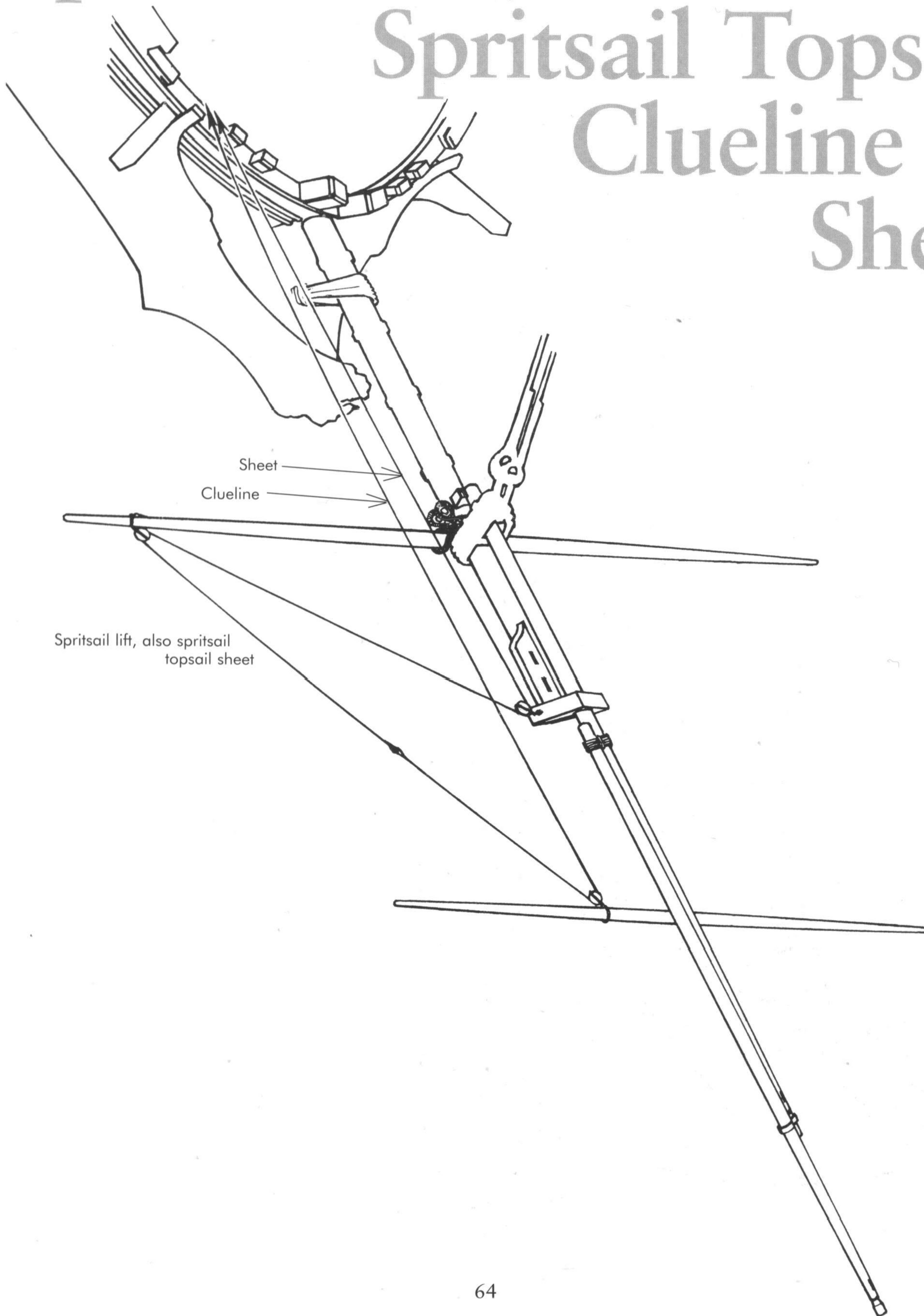

Spritsail Clueline & Sheet

Spritsail Topsail Lift

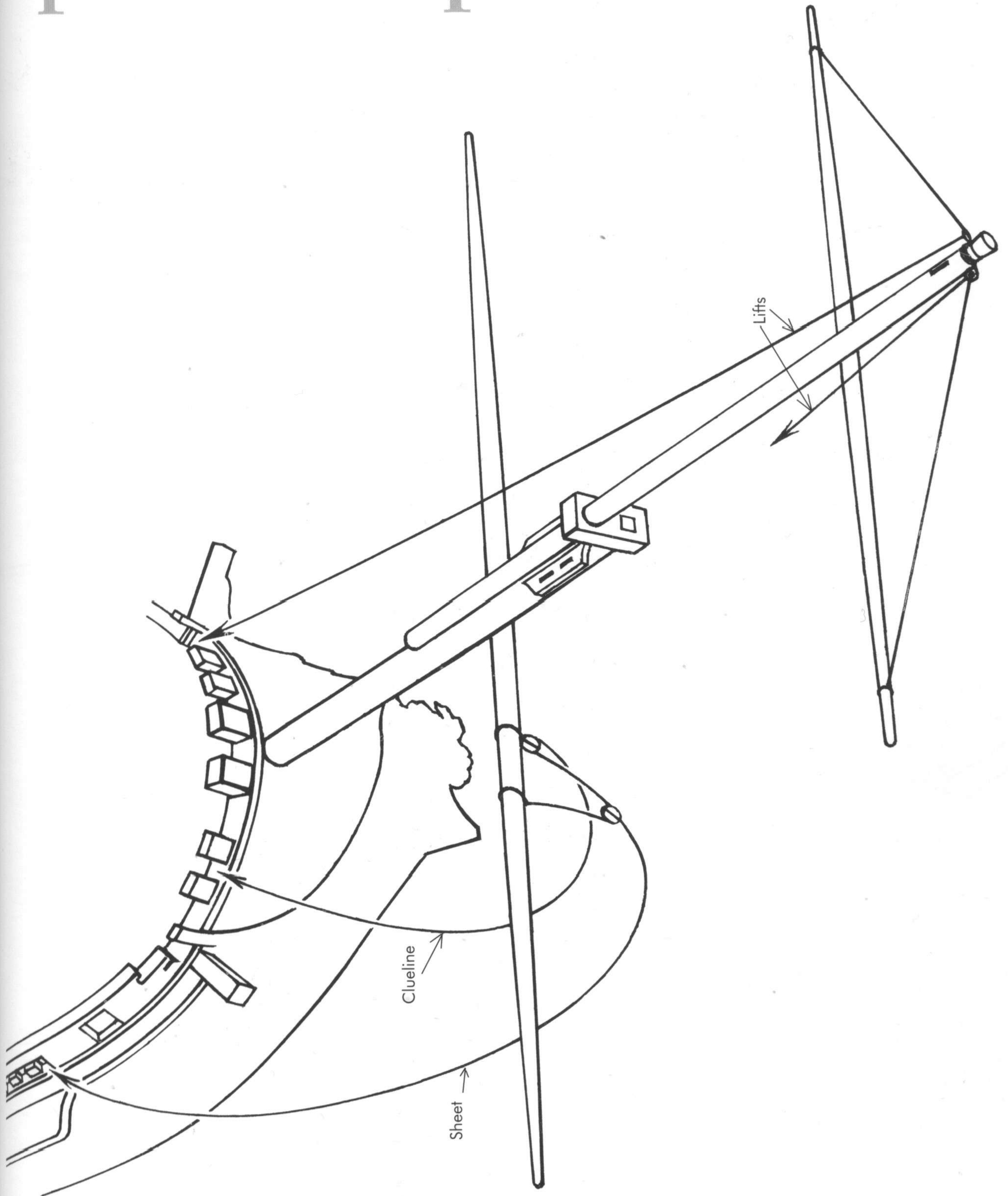

Fore Topsail Reef Tackle

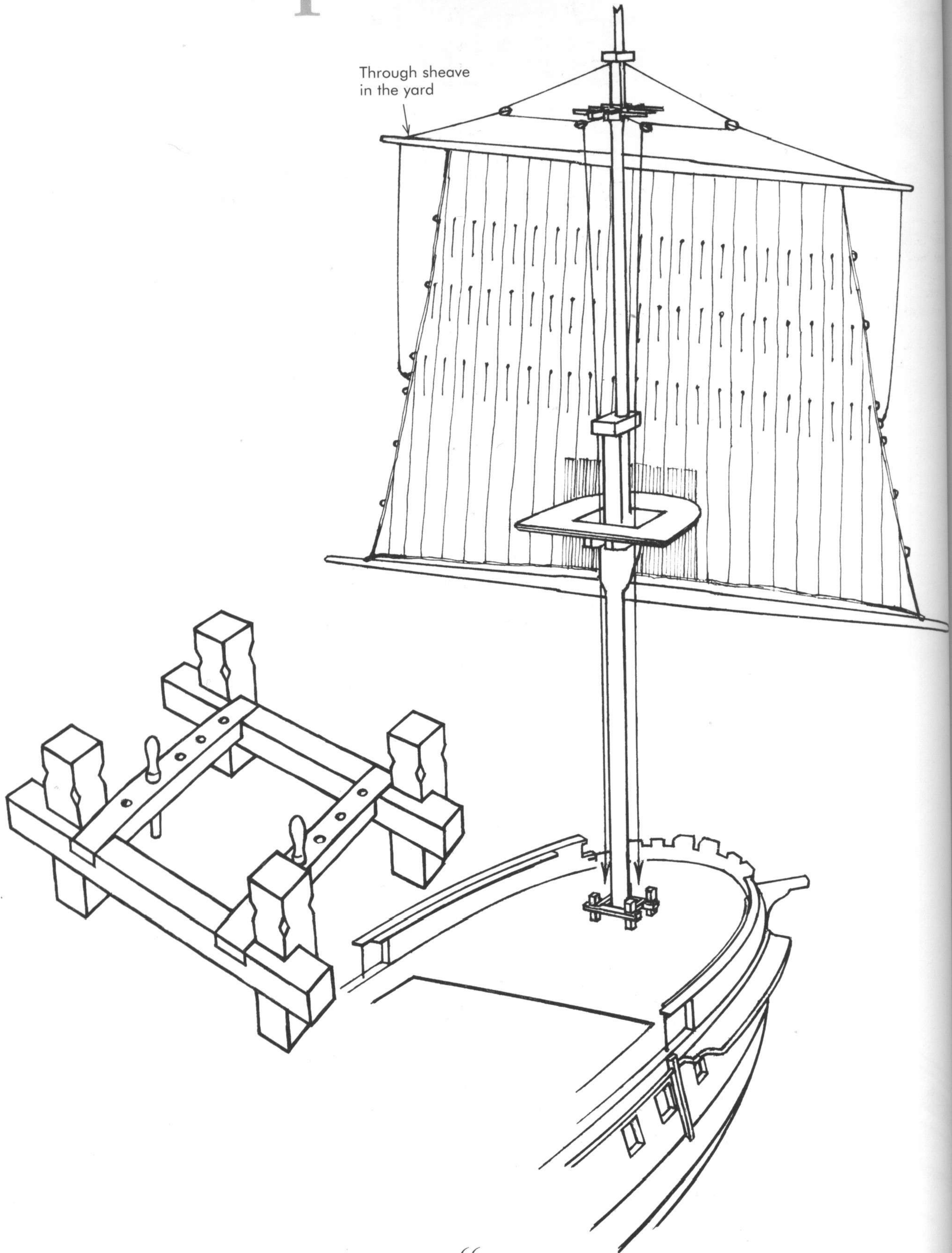

Main Topsail Reef Tackle

Through sheave
in the yard

Note:
Reef tackles and pendants were
not carried on the lower yards
until the early nineteenth
century. The courses were reefed
by hauling the sail manually up
to the yard, possibly assisted by
hauling on the leechlines.

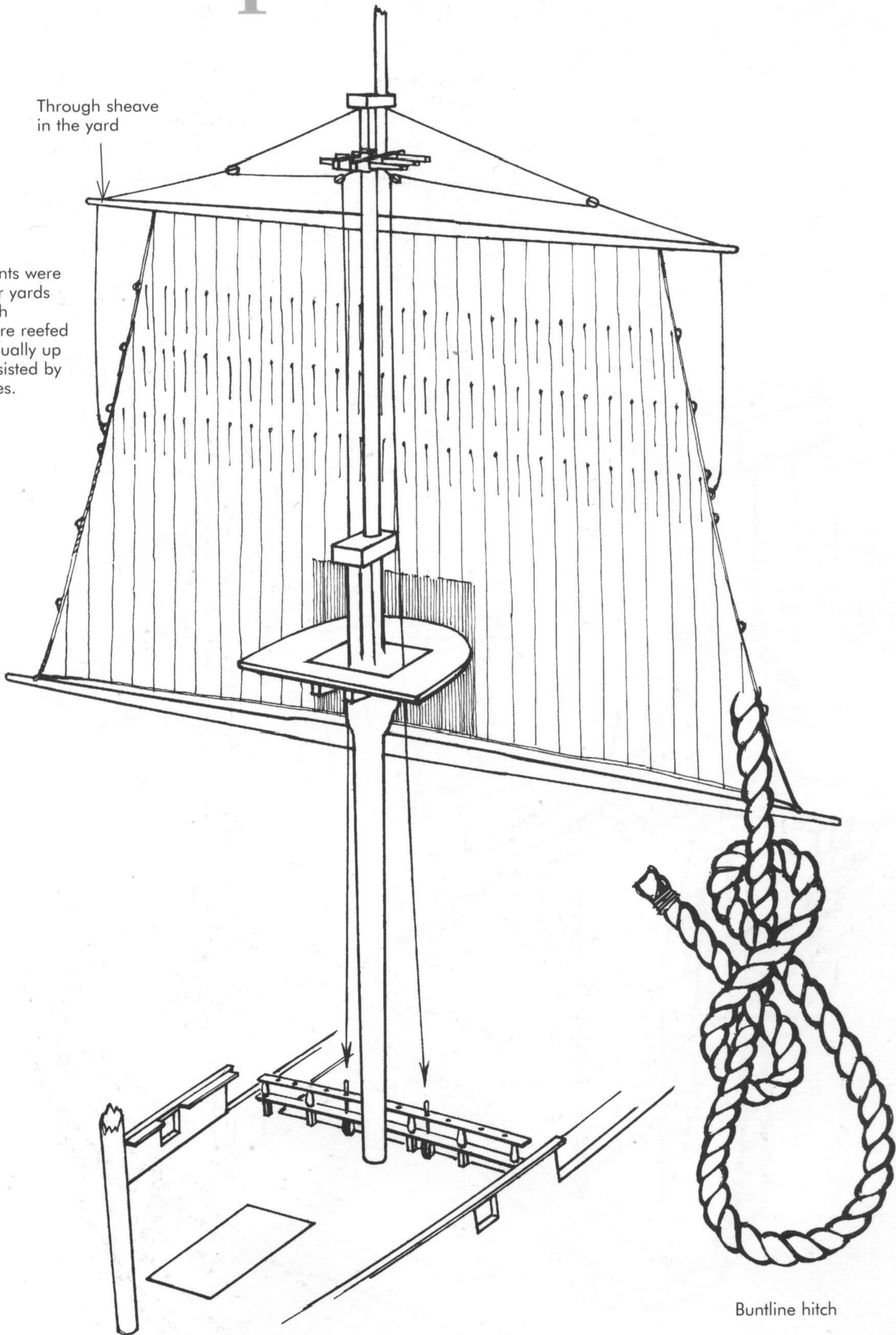

Buntline hitch

Mizzen Topsail Reef Tackle

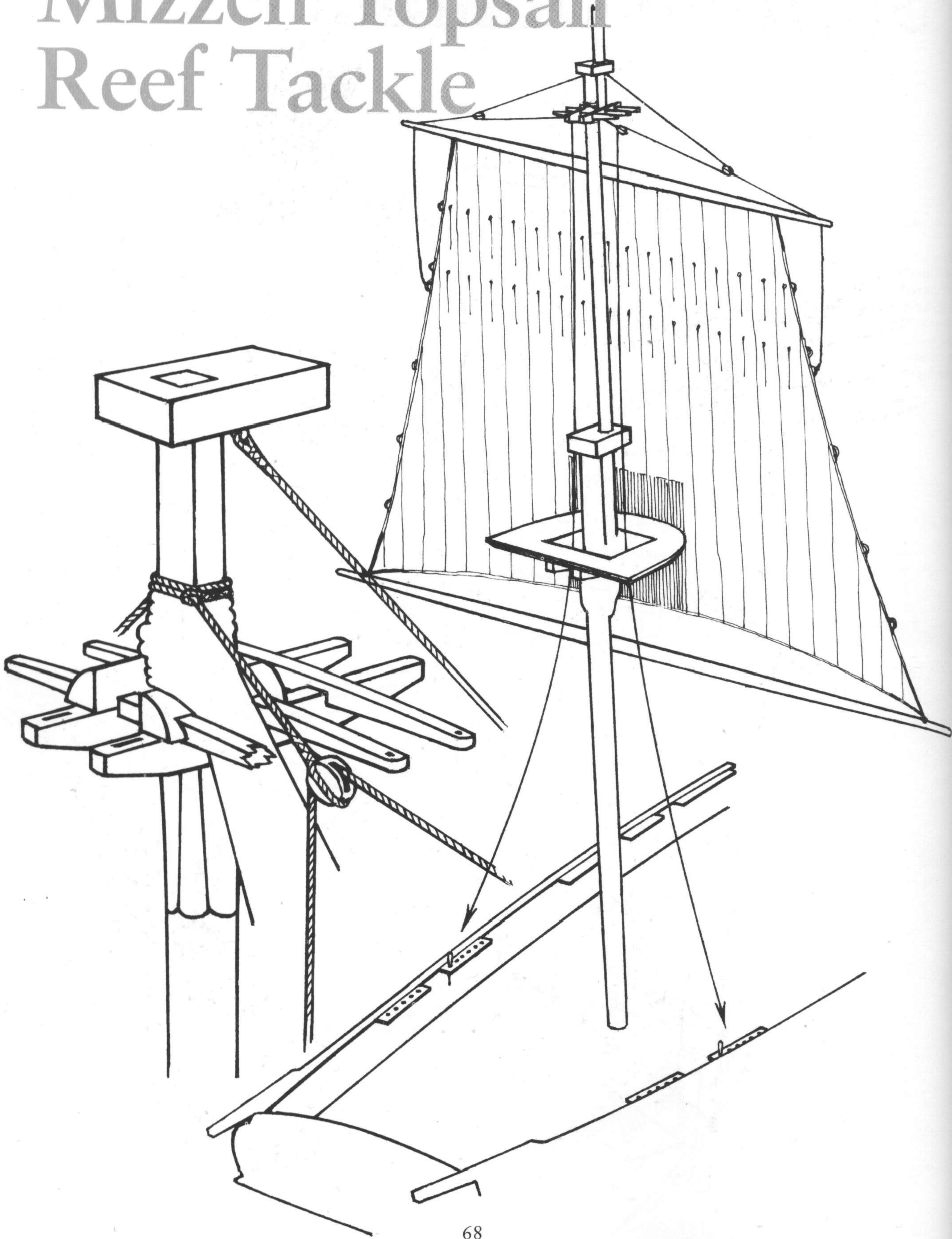

Spritsail Buntlines

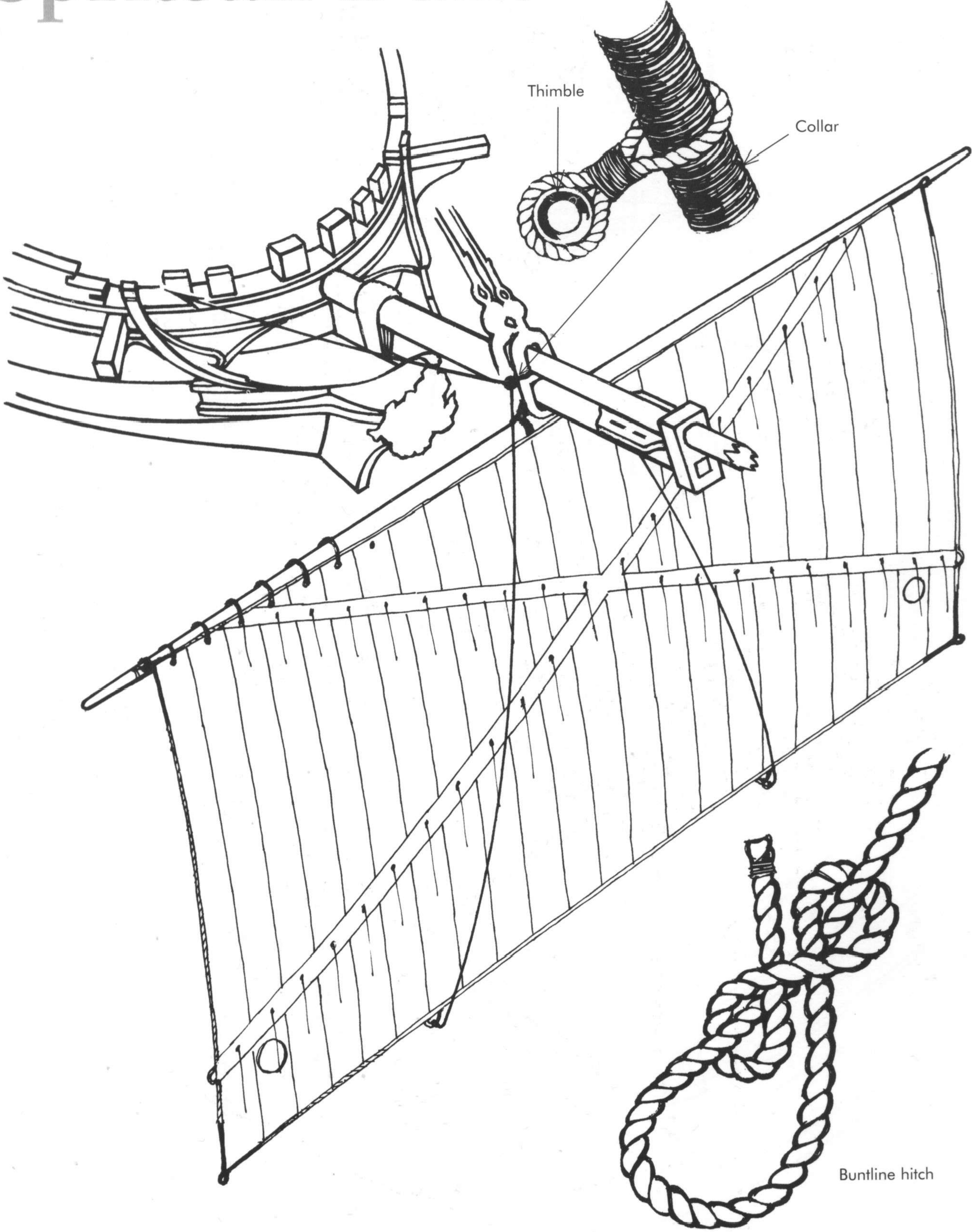

Fore Course Buntlines & Leechlines

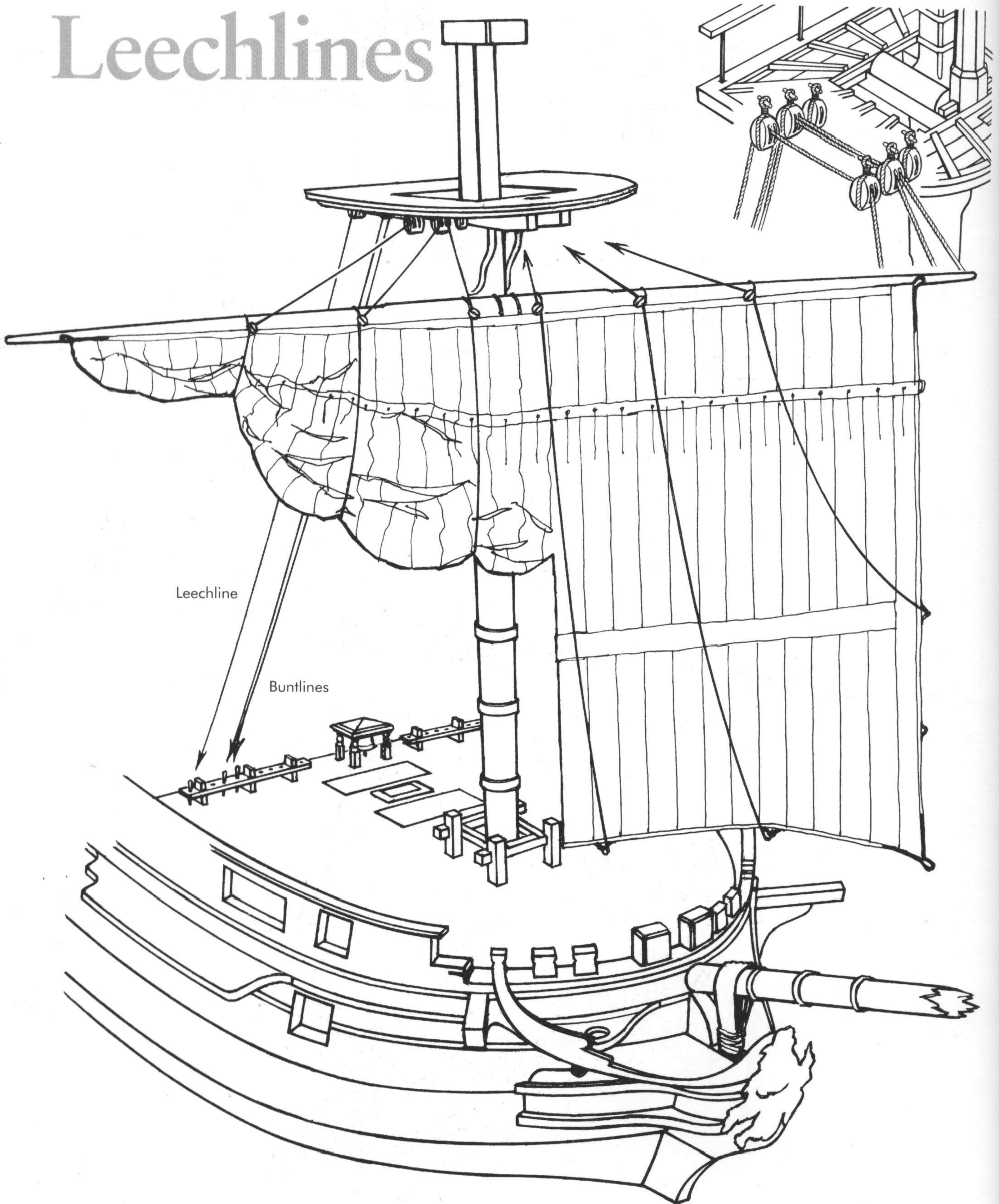

Fore Topsail Buntlines

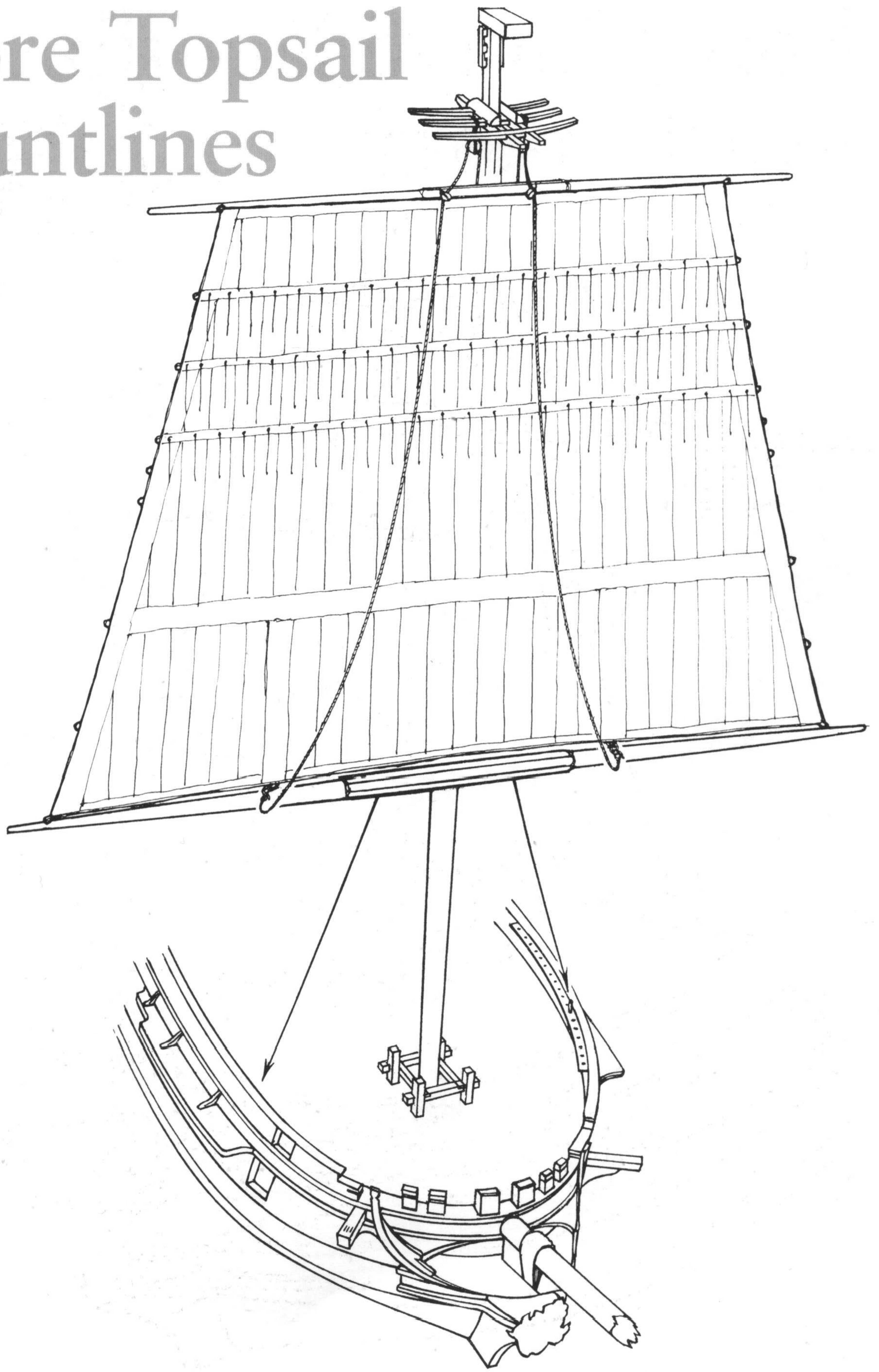

Main Course Buntlines & Leechlines

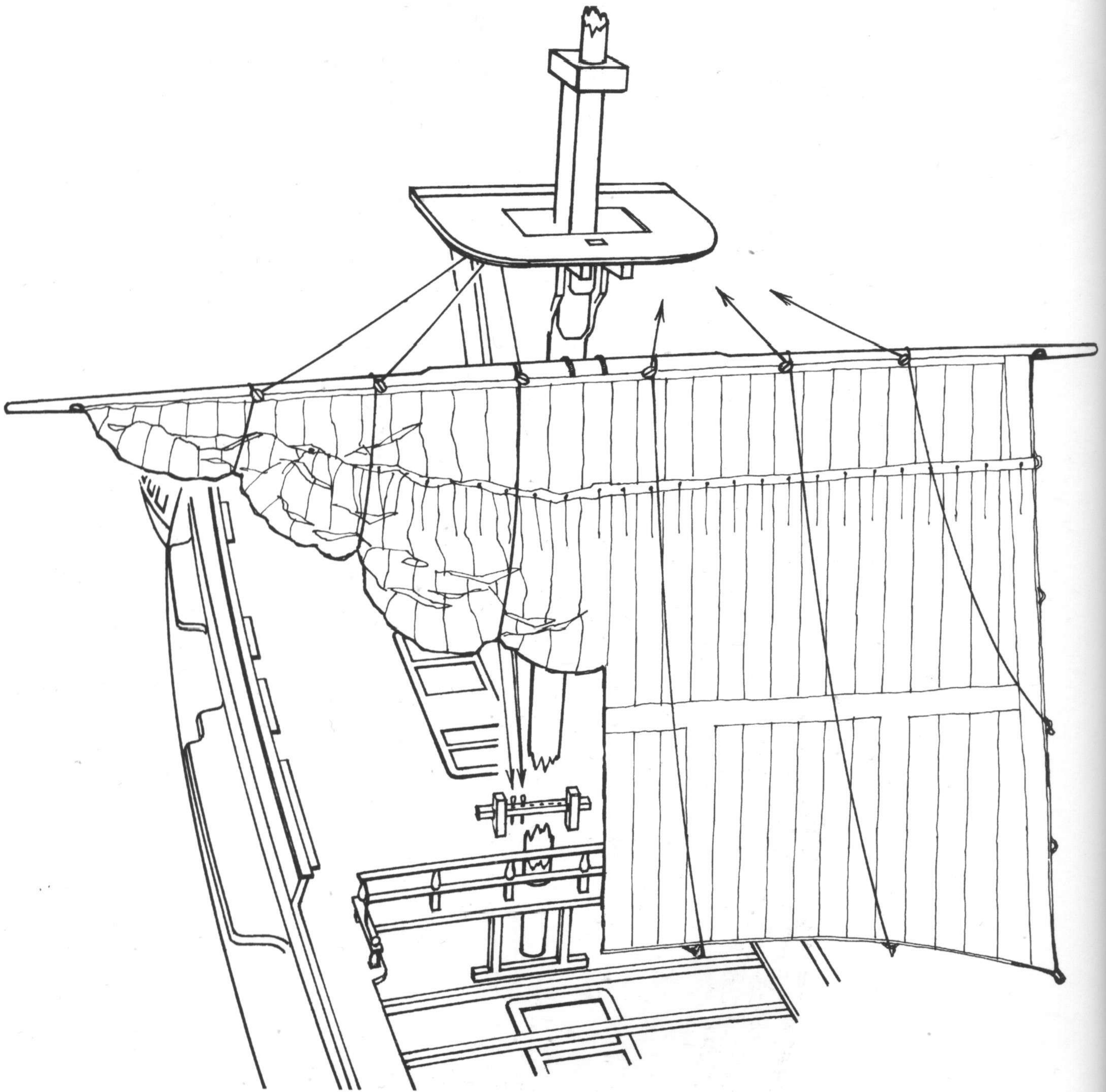

Main Topsail Buntlines

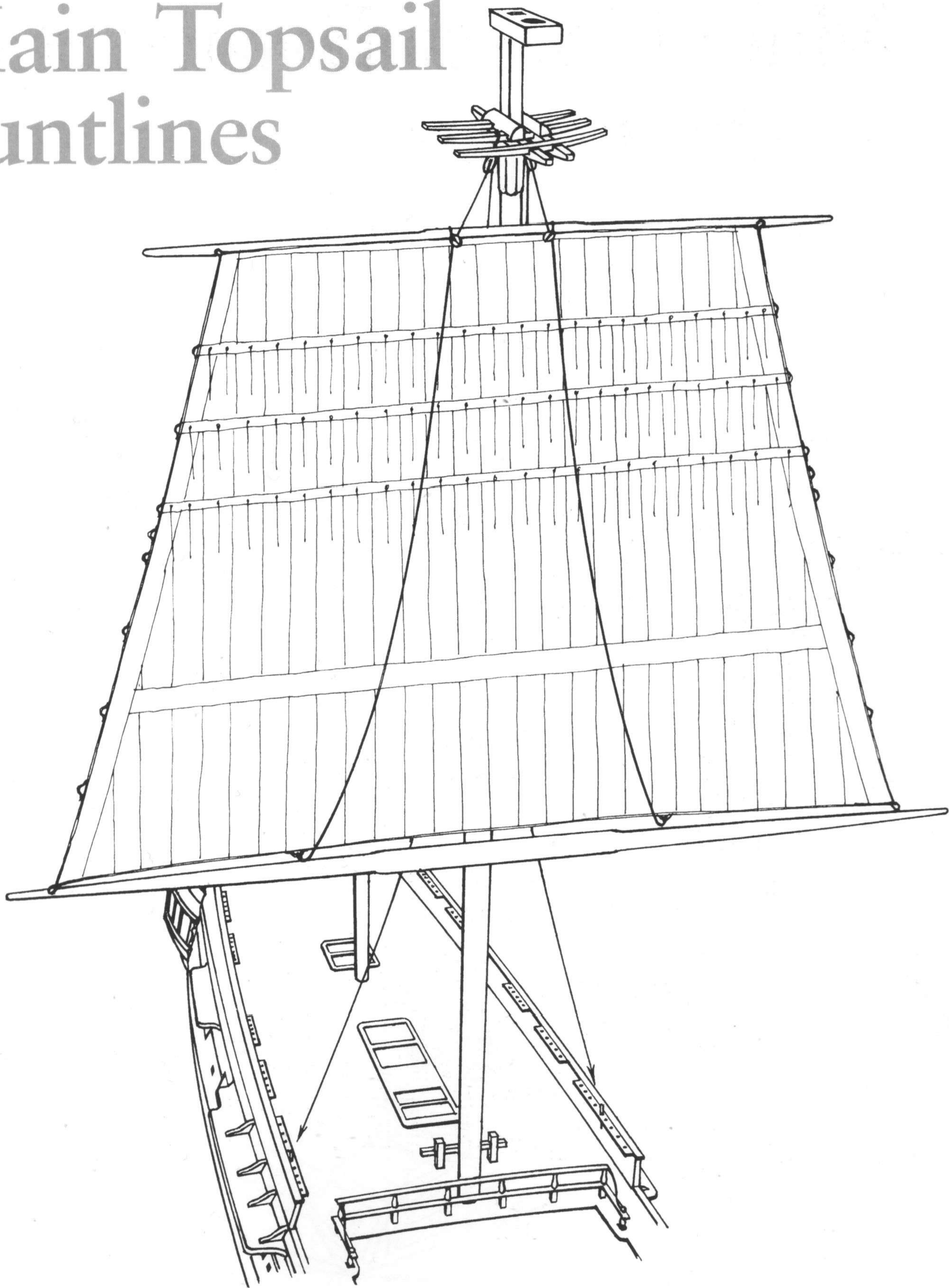

Mizzen Topsail Buntlines

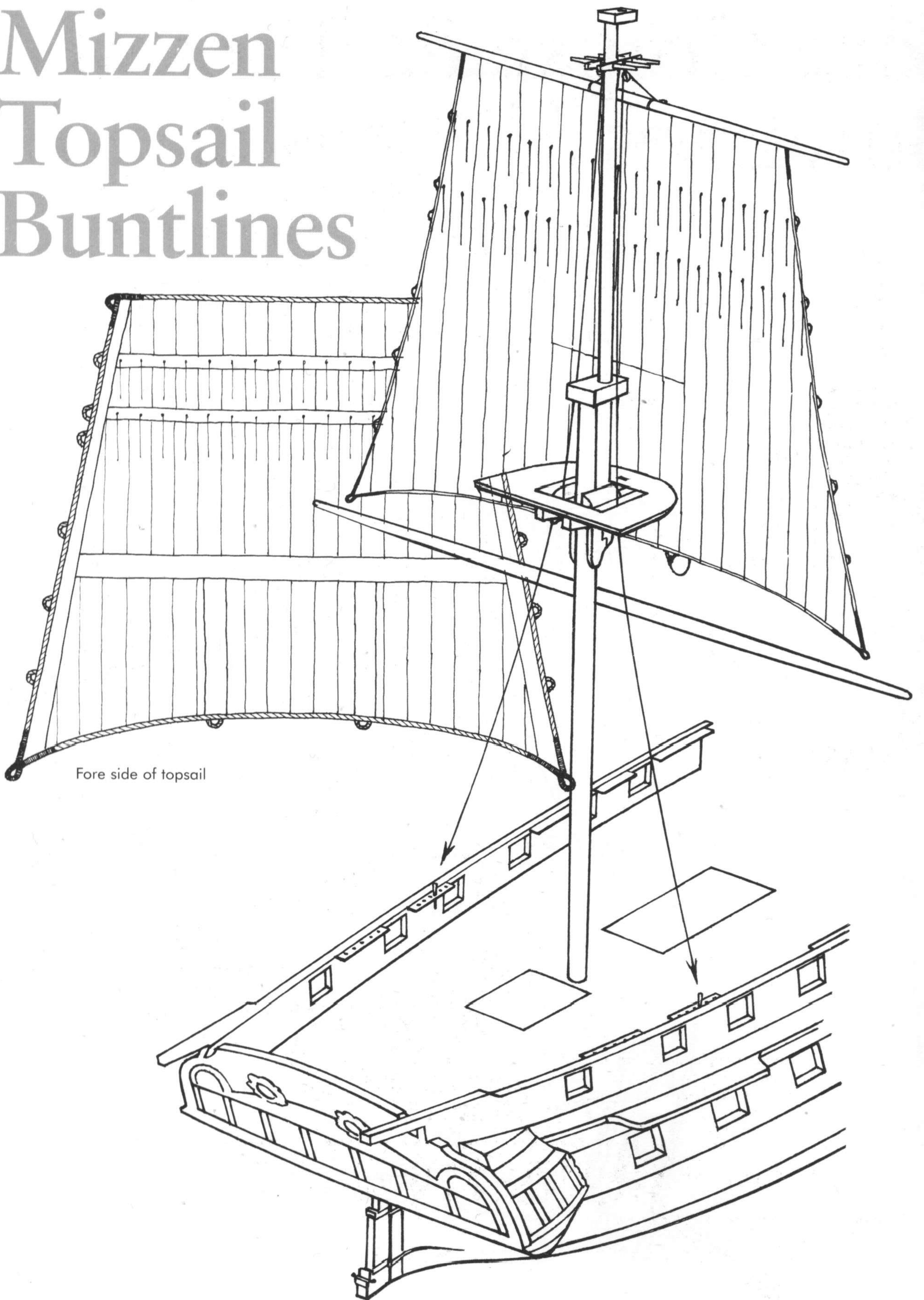

Fore side of topsail

Fore Course & Topsail Bowlines

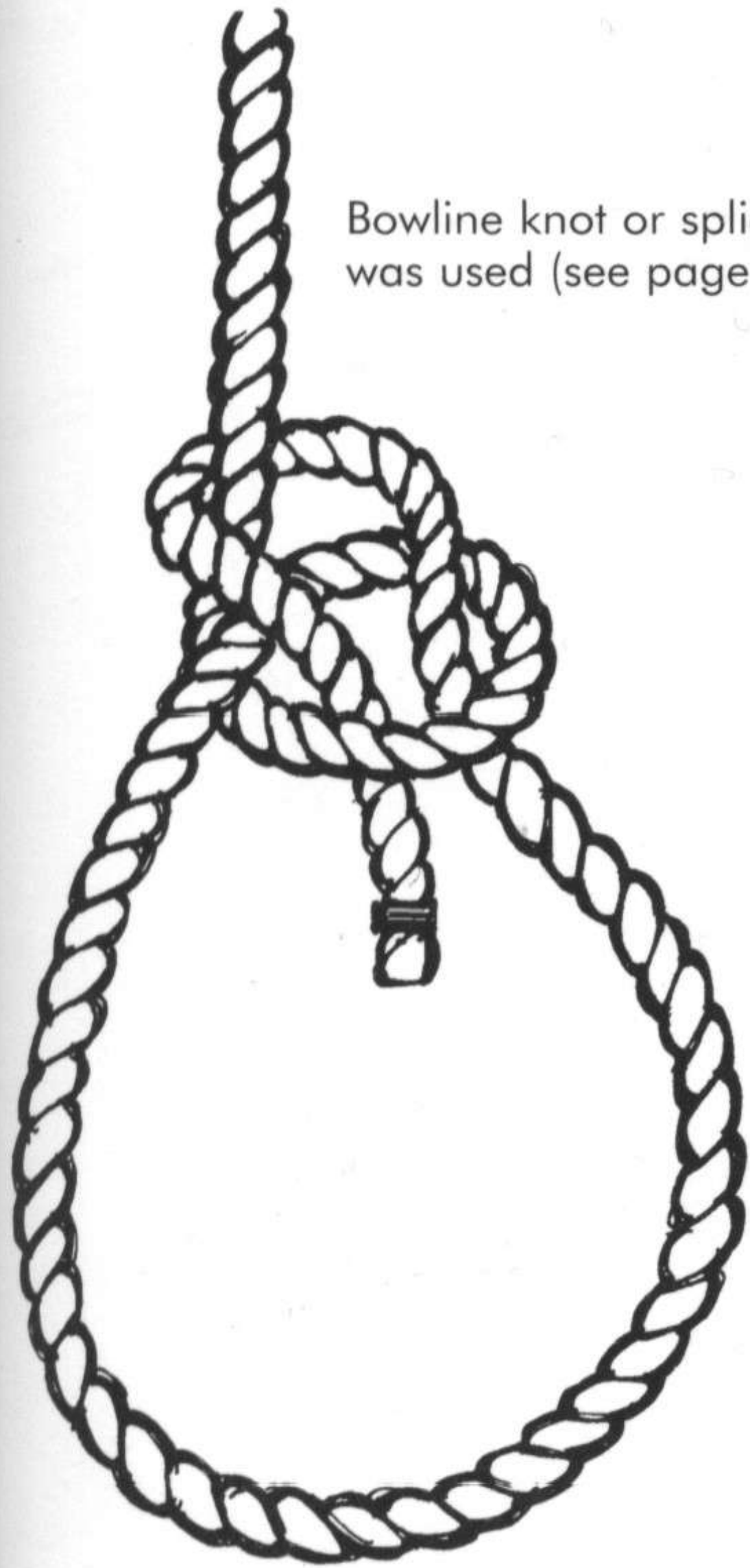

Bowline knot or splice
was used (see page 76)

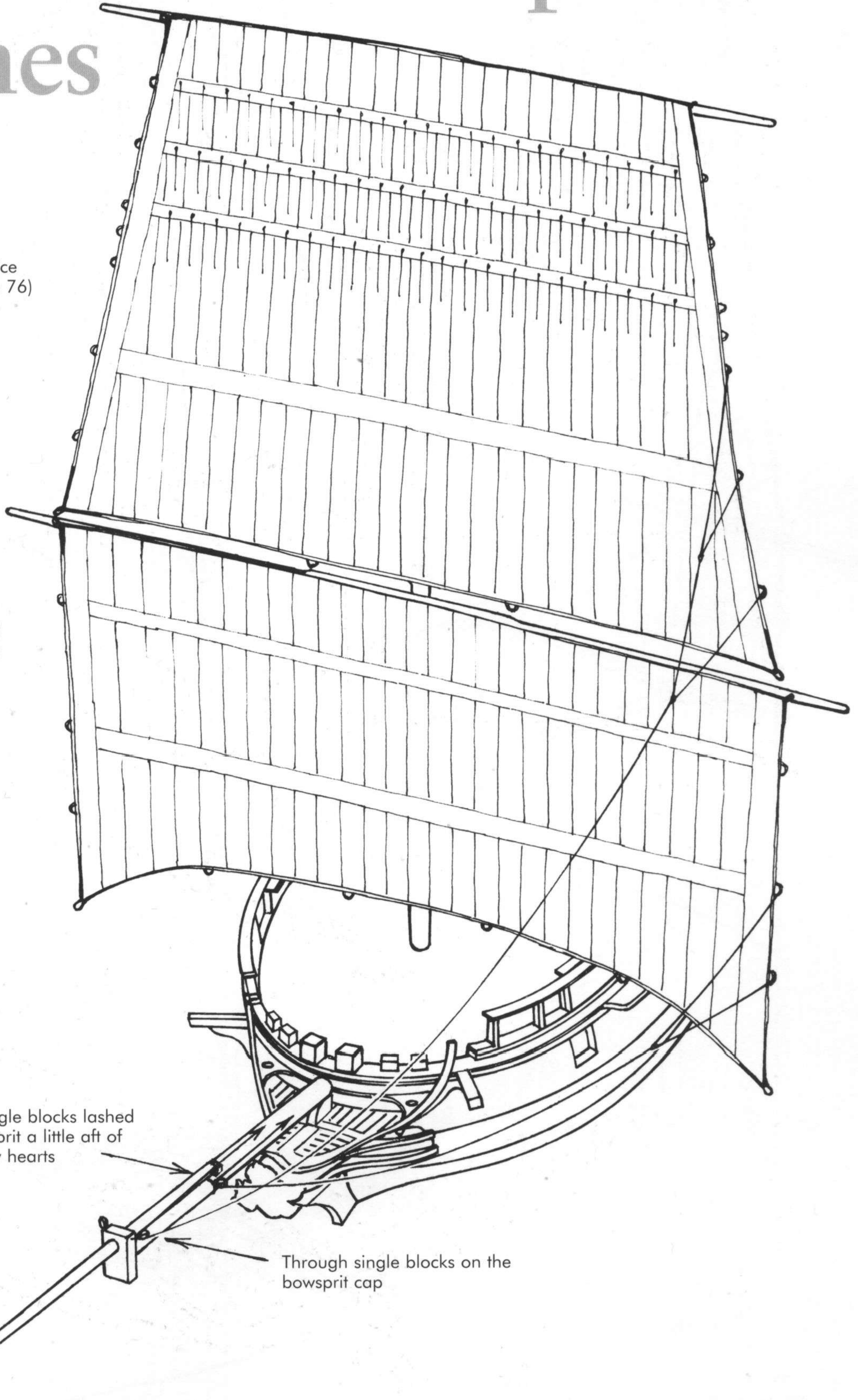

Through single blocks lashed
to the bowsprit a little aft of
the fore stay hearts

Through single blocks on the
bowsprit cap

Fore Topgallant Bowlines

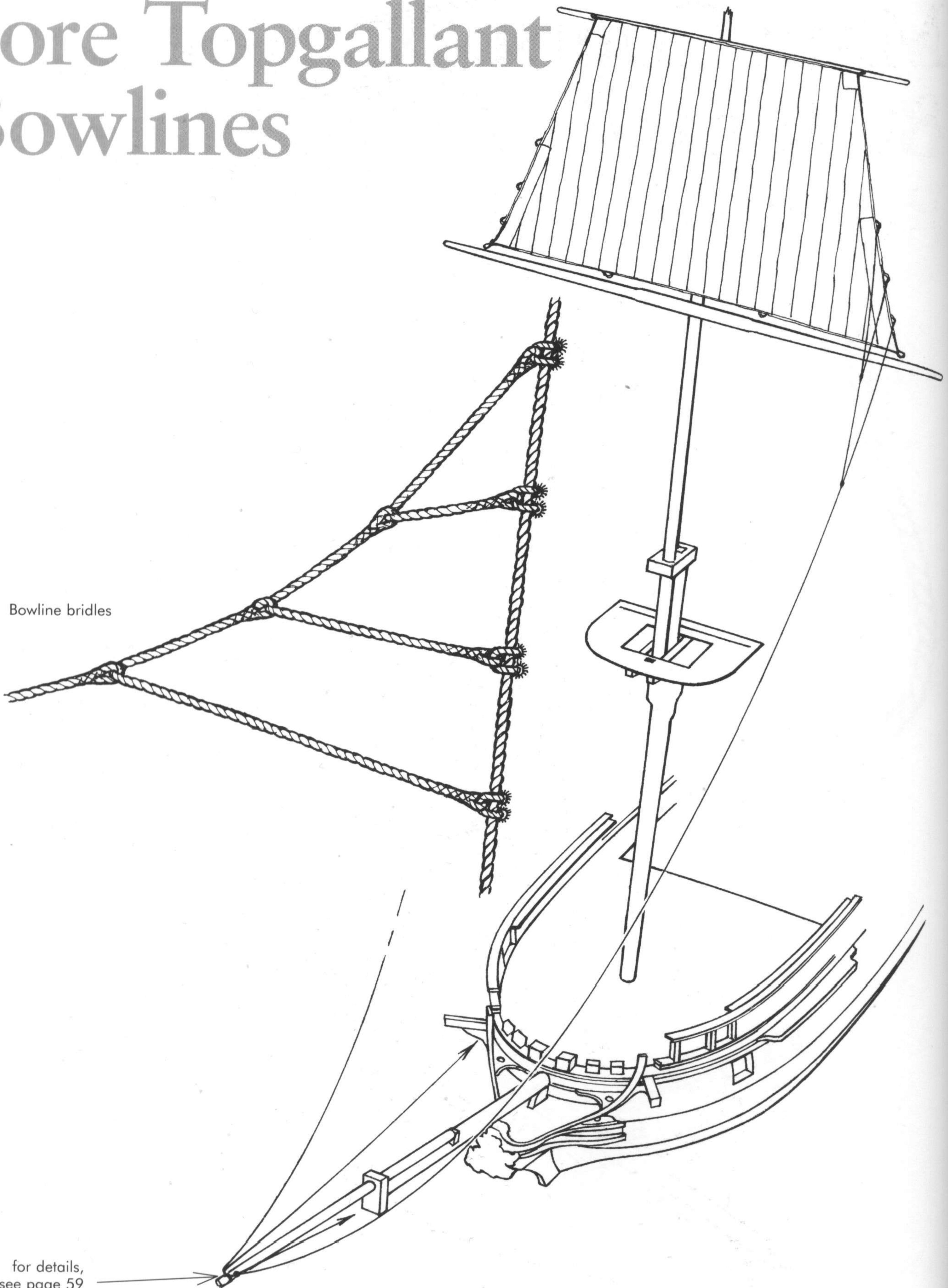

Main Course & Topsail Bowlines

The lead blocks are carried on the
aftermost fore shroud – about
6 feet below the futtock stave

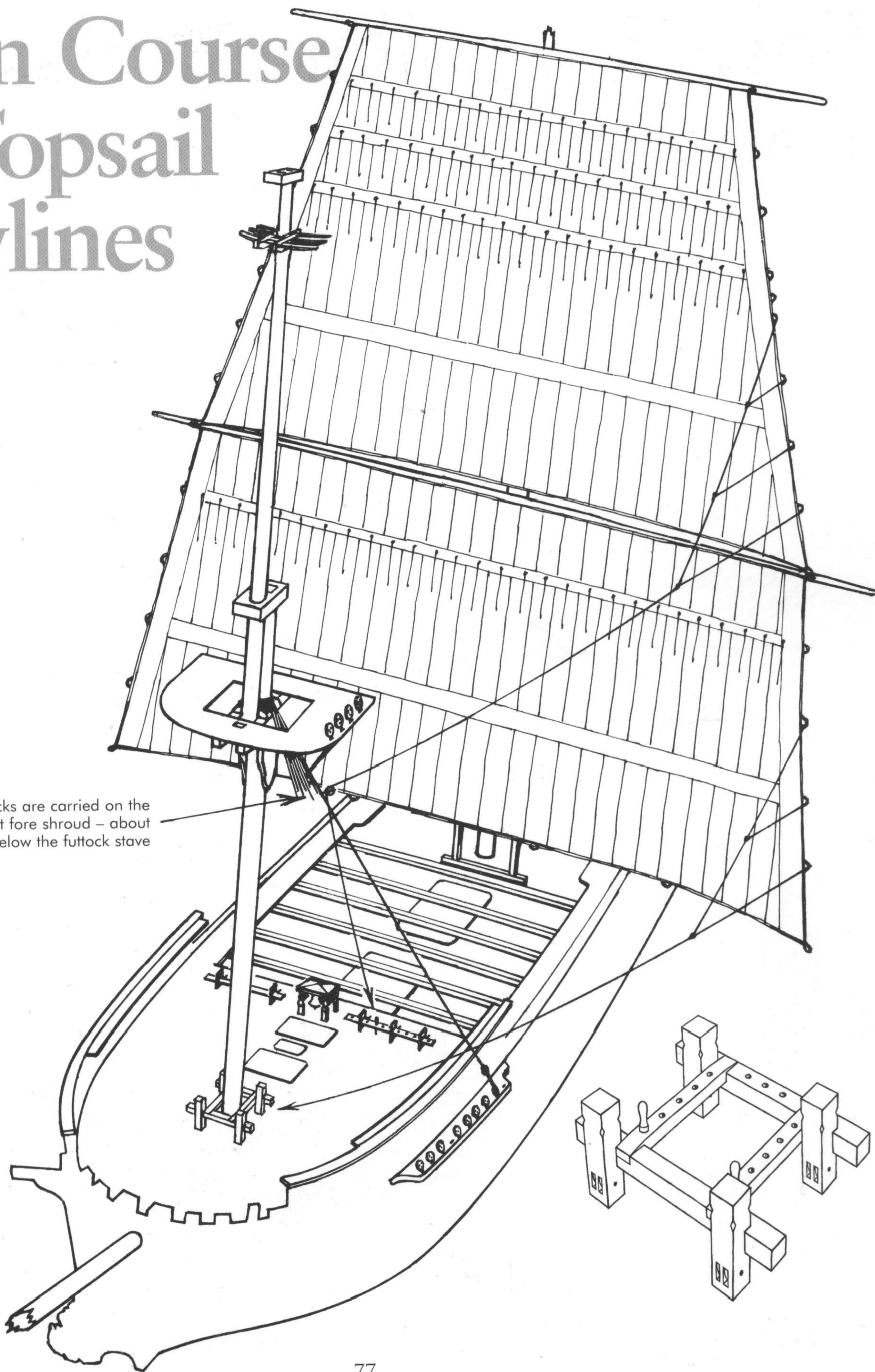

Main Topgallant Bowlines

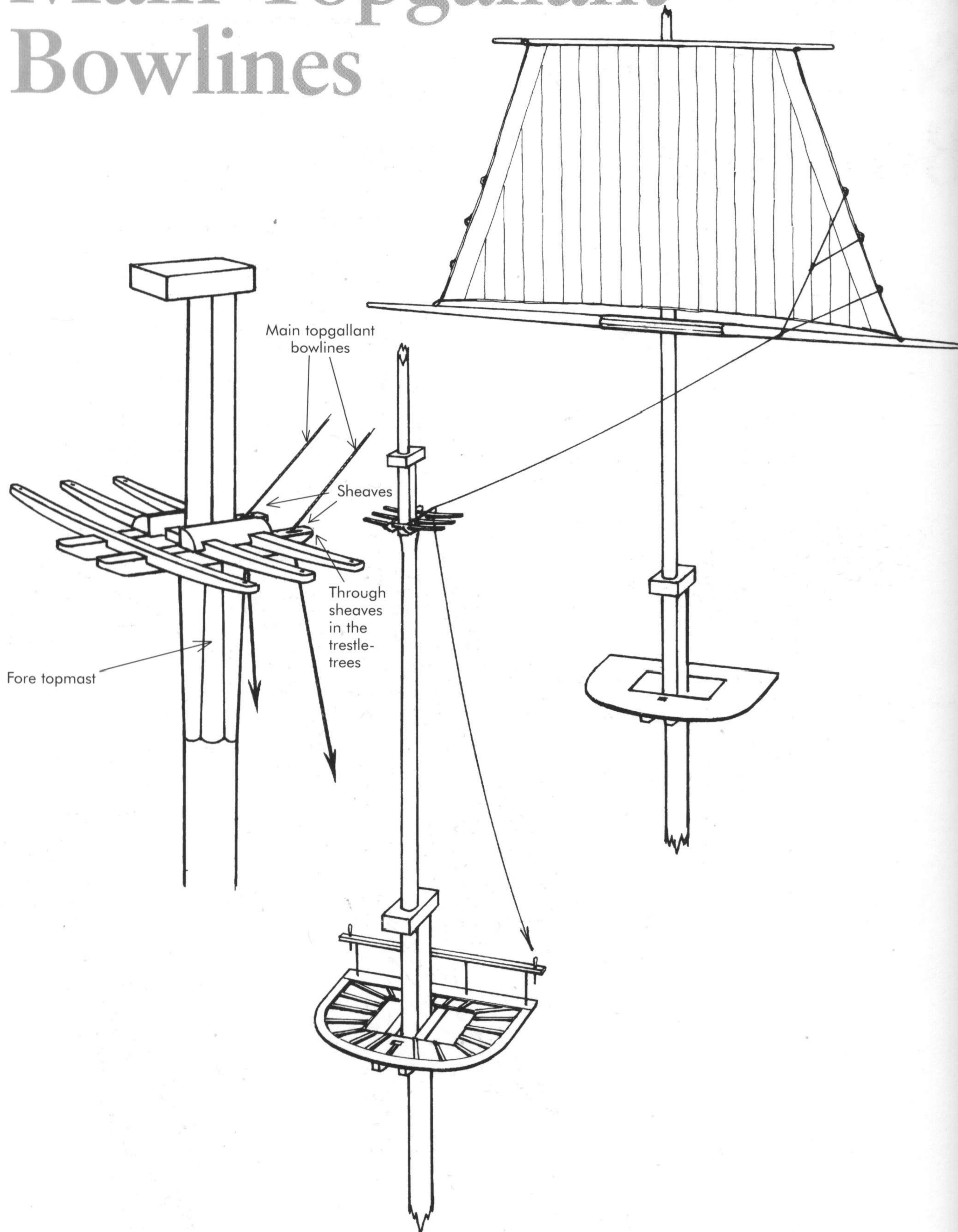

Mizzen Topsail & Topgallant Bowlines

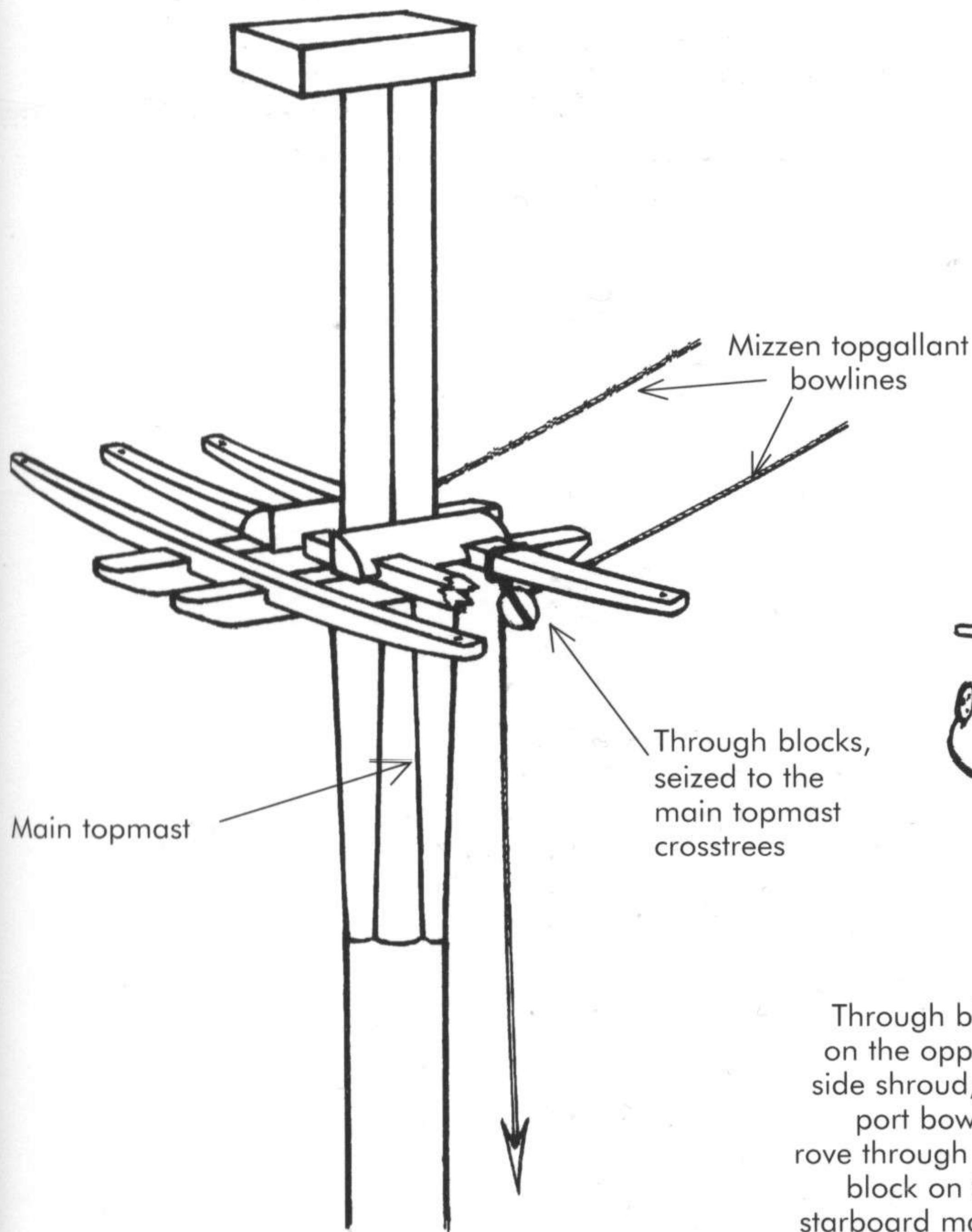

Through blocks on the opposite side shroud; the port bowline rove through the block on the starboard main shroud and vice versa

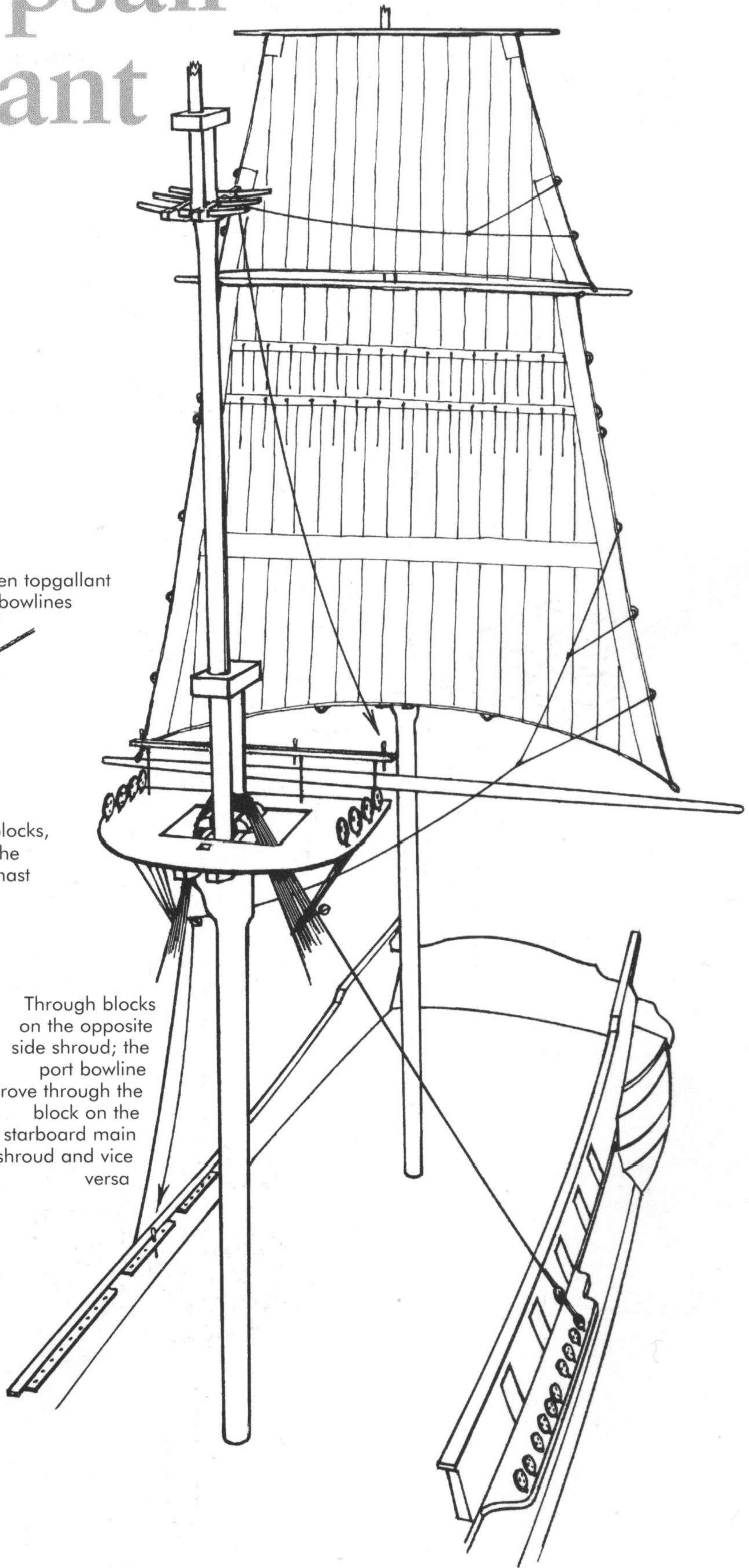

Mizzen Mast Square Sails

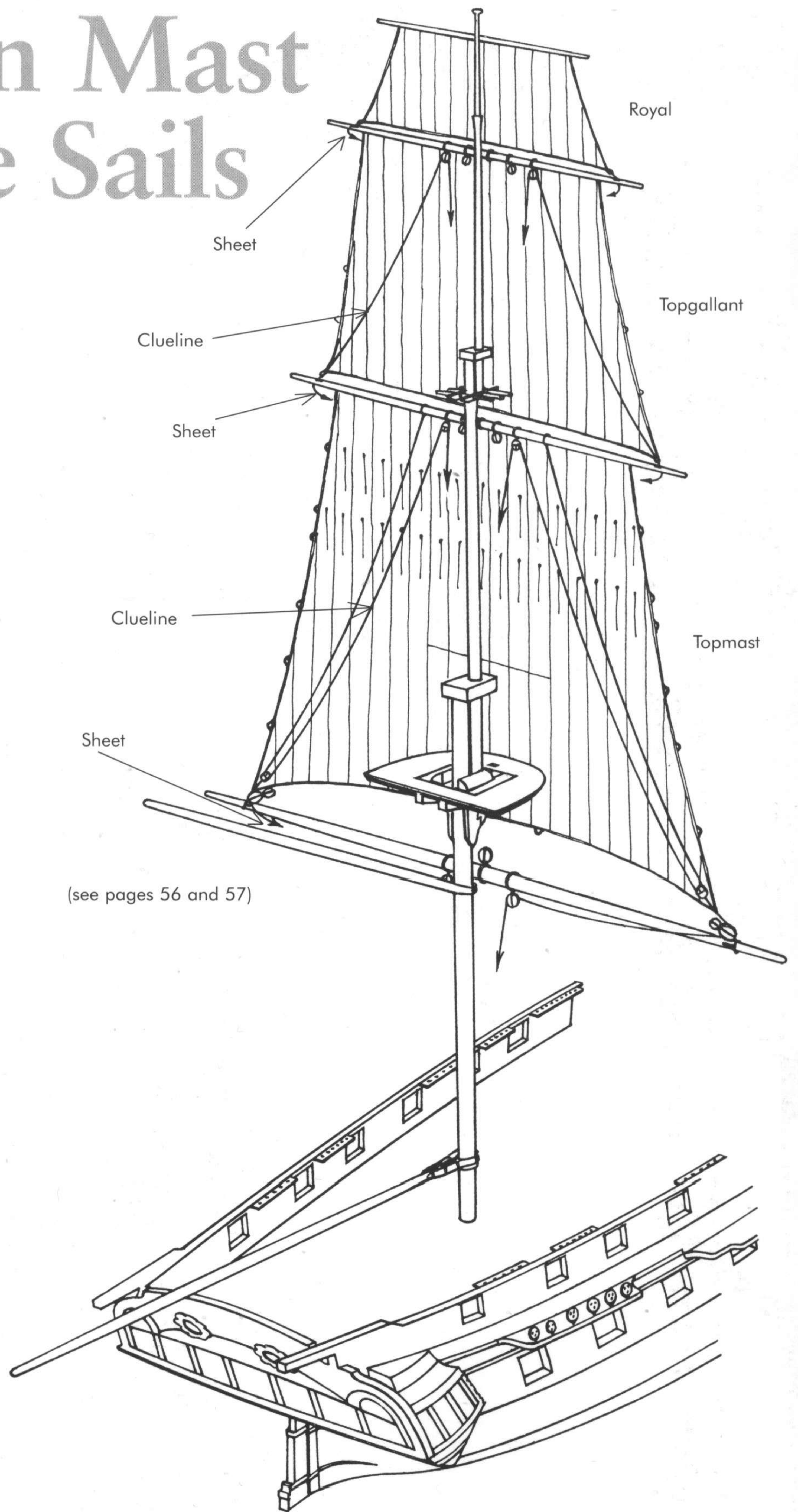

Spanker

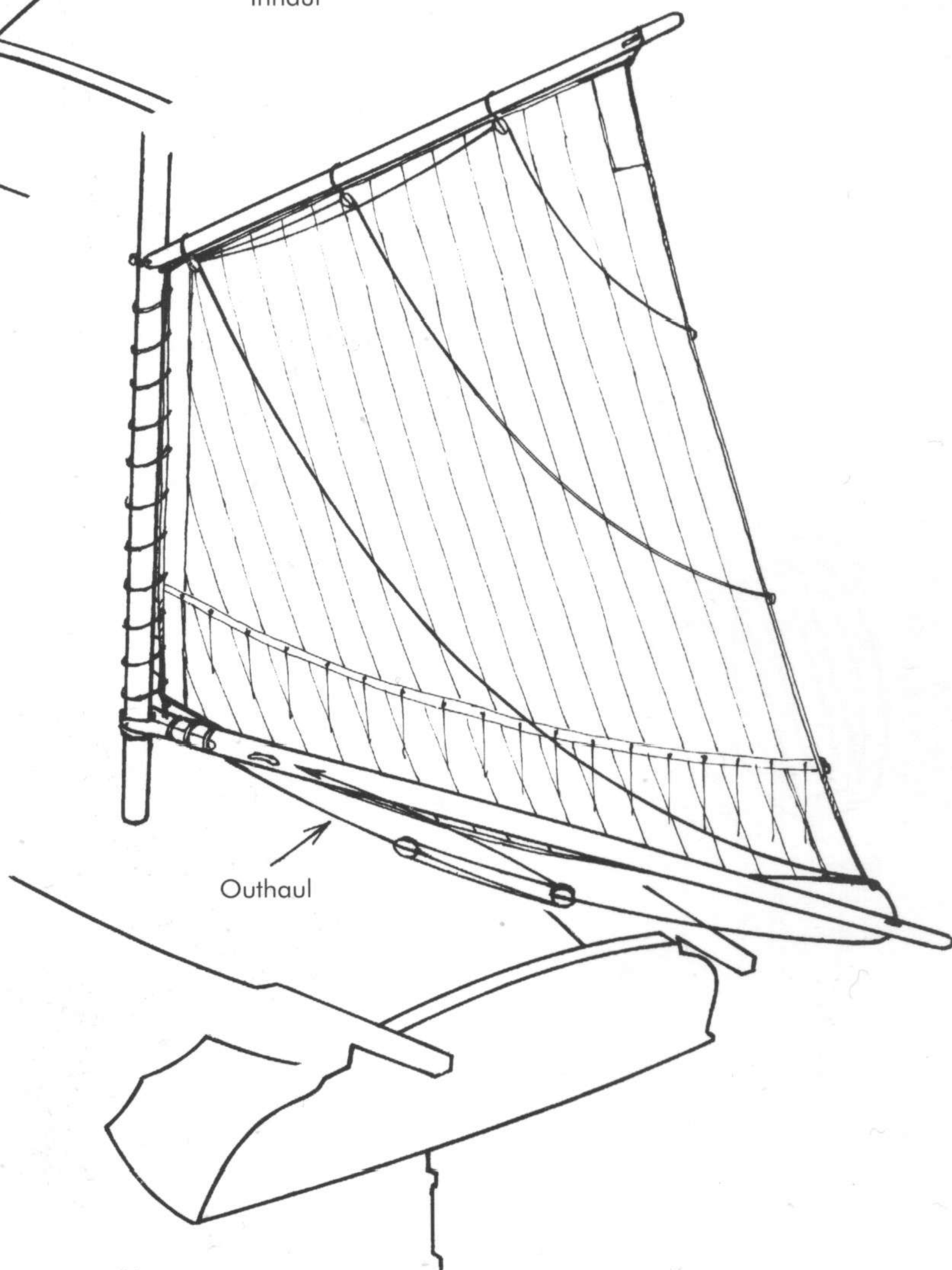
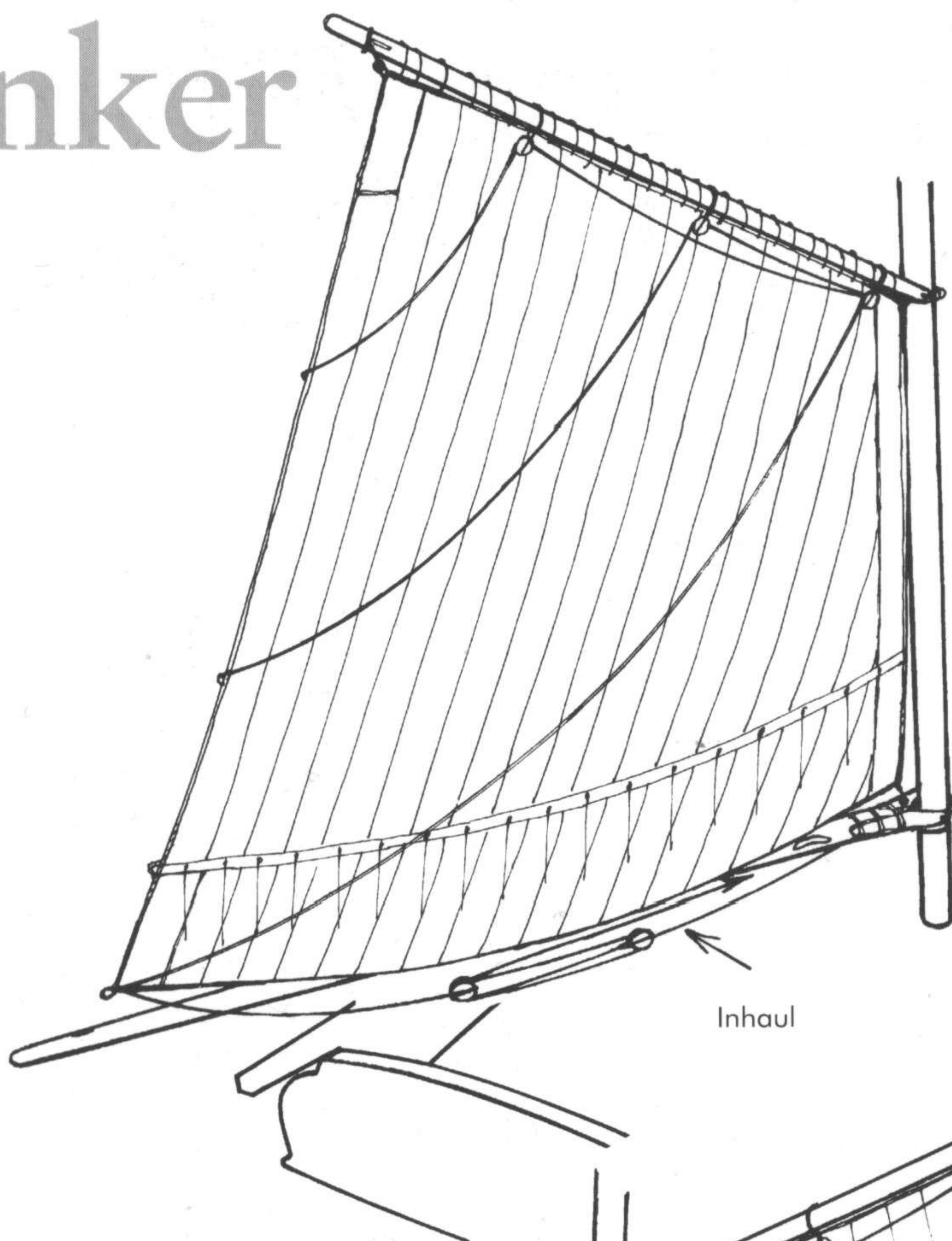
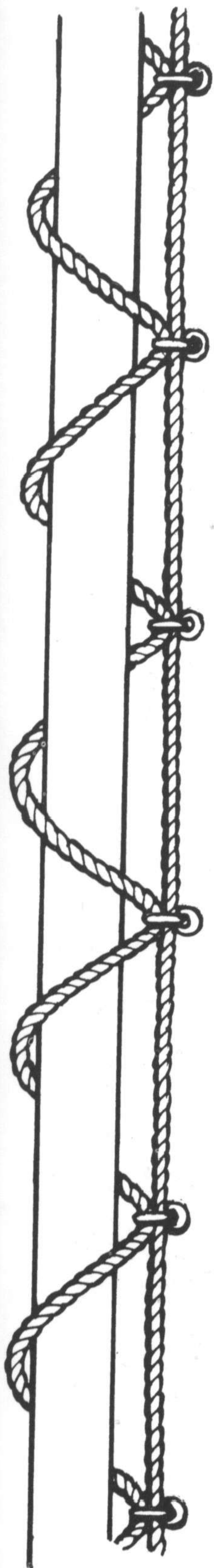

Mainmast Square Sails

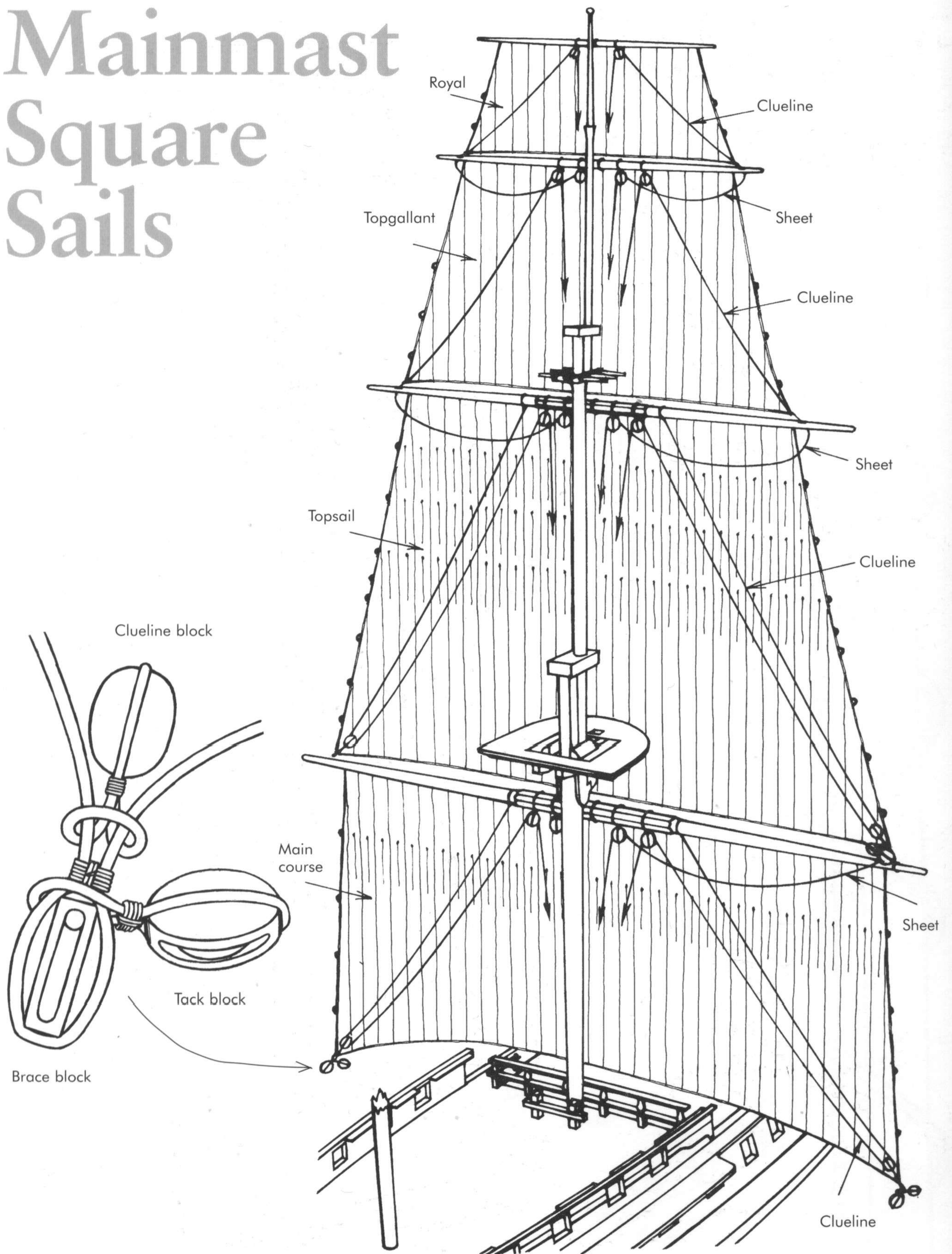

Fore Mast Square Sails

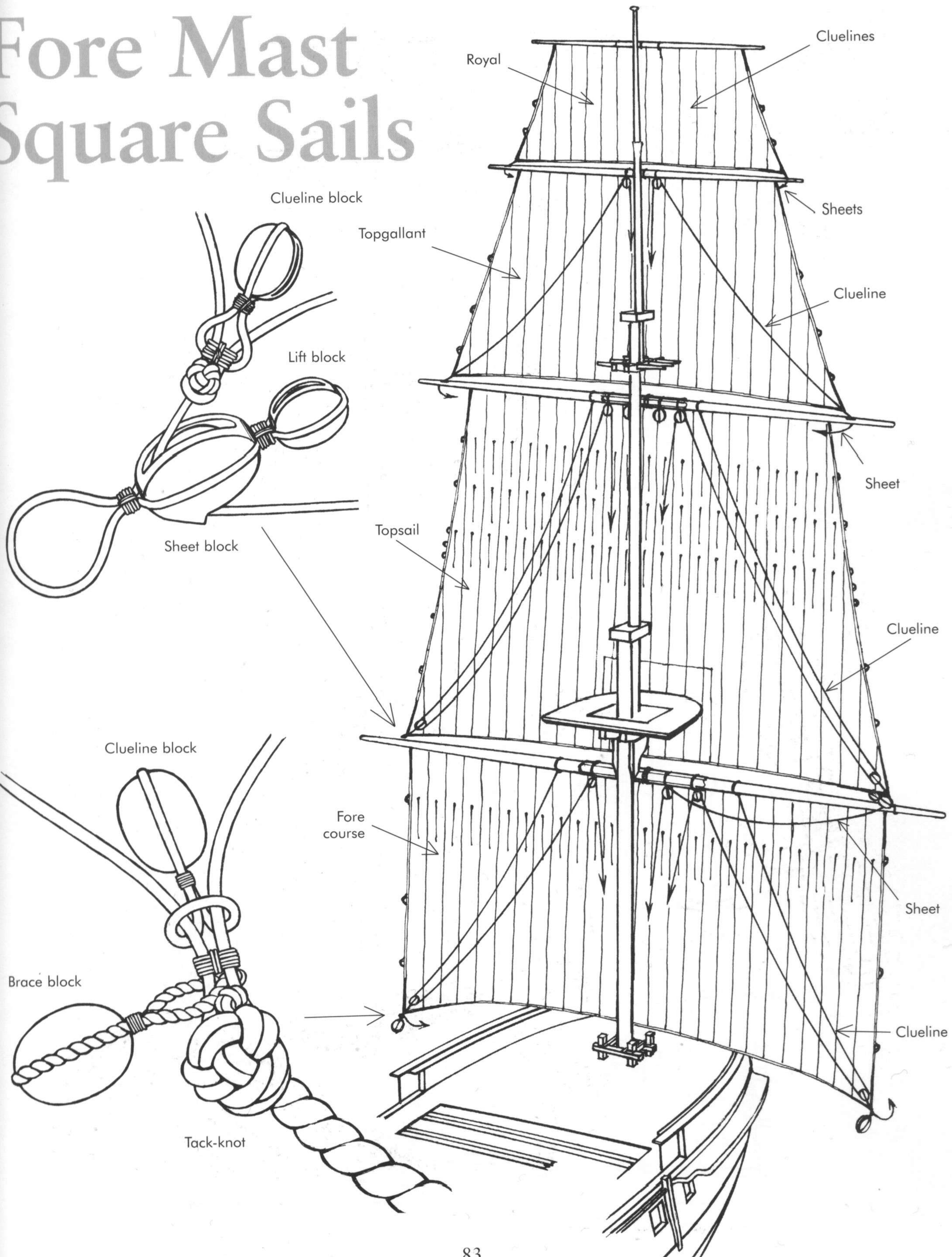

Yard Tackle & Tricing Lines

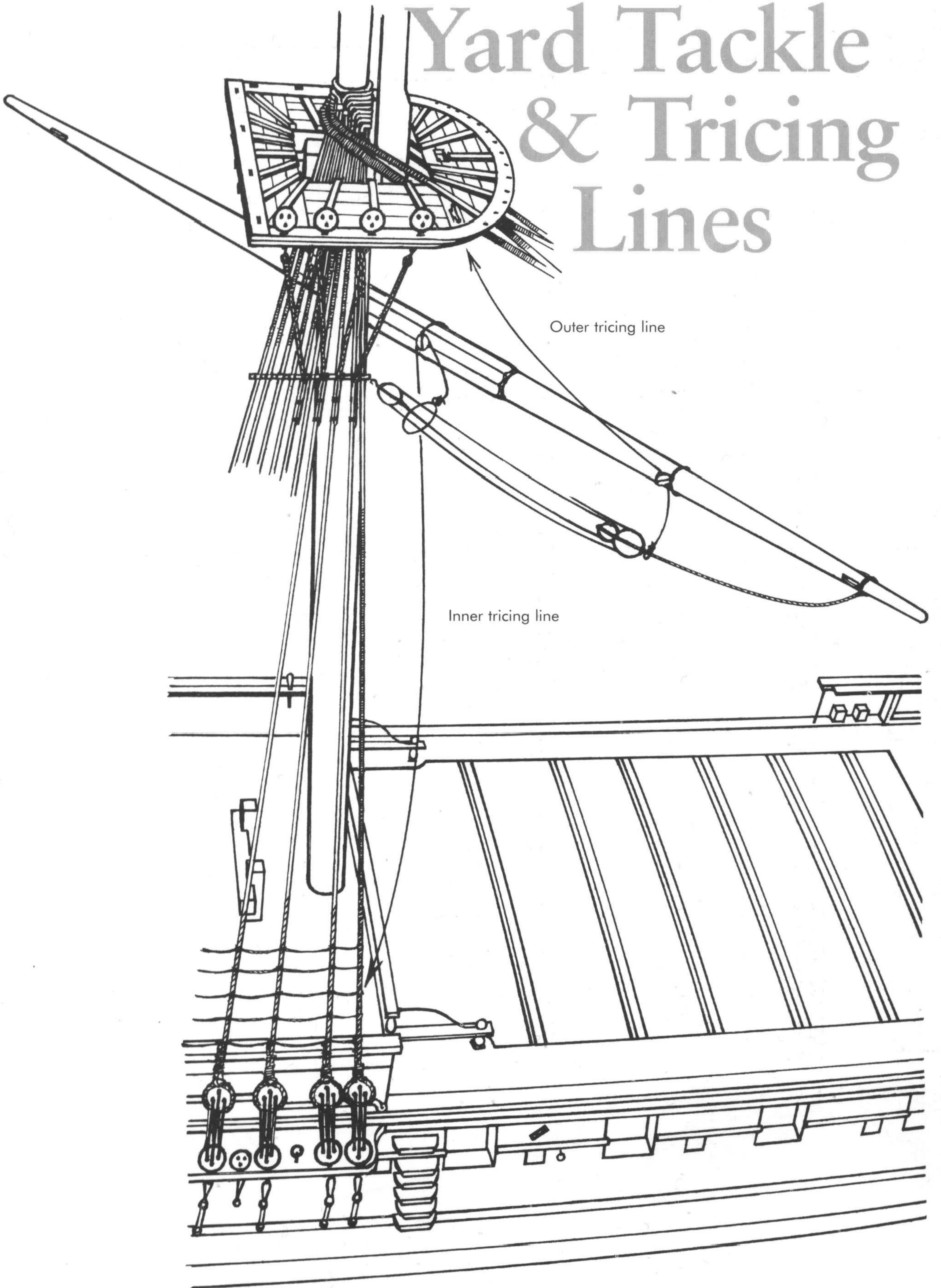

Outer tricing line

Inner tricing line

Yards

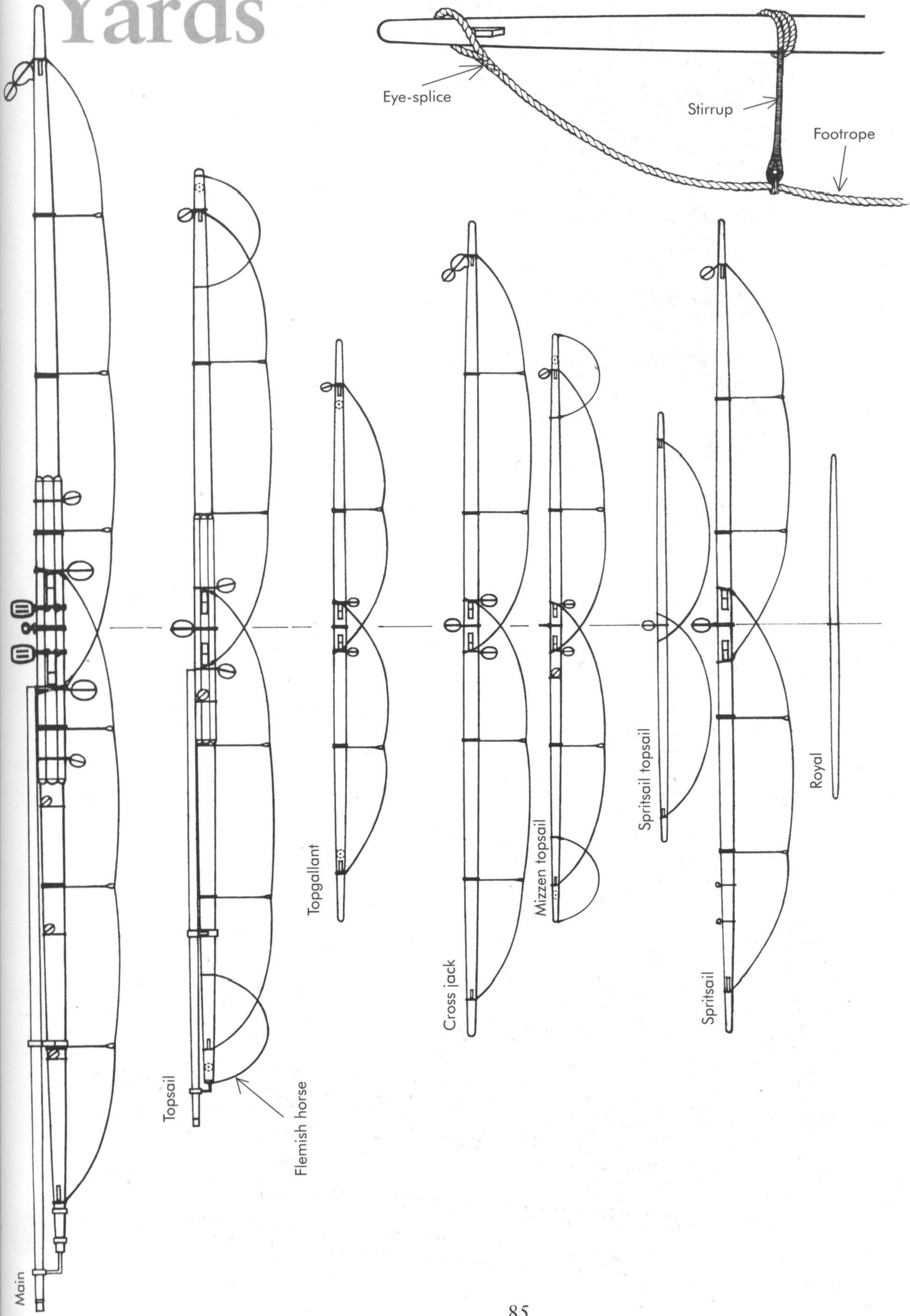

Main Yard with Stun- Sail Boom & Stunsail Boom Irons

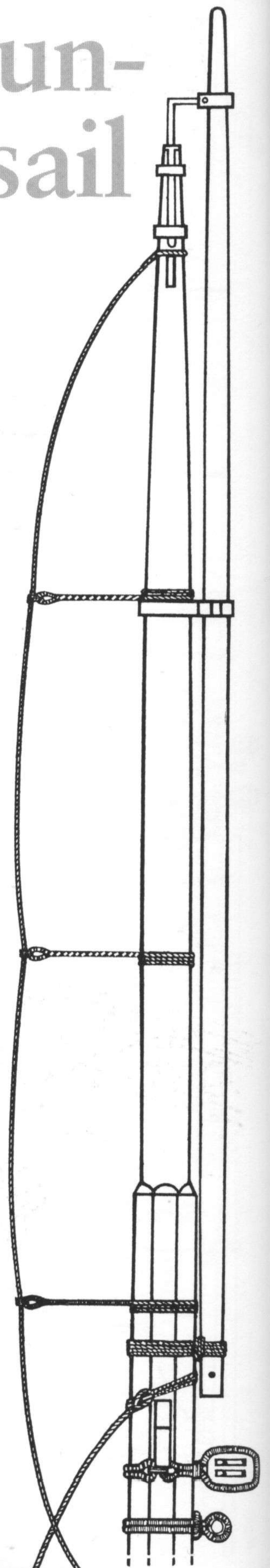
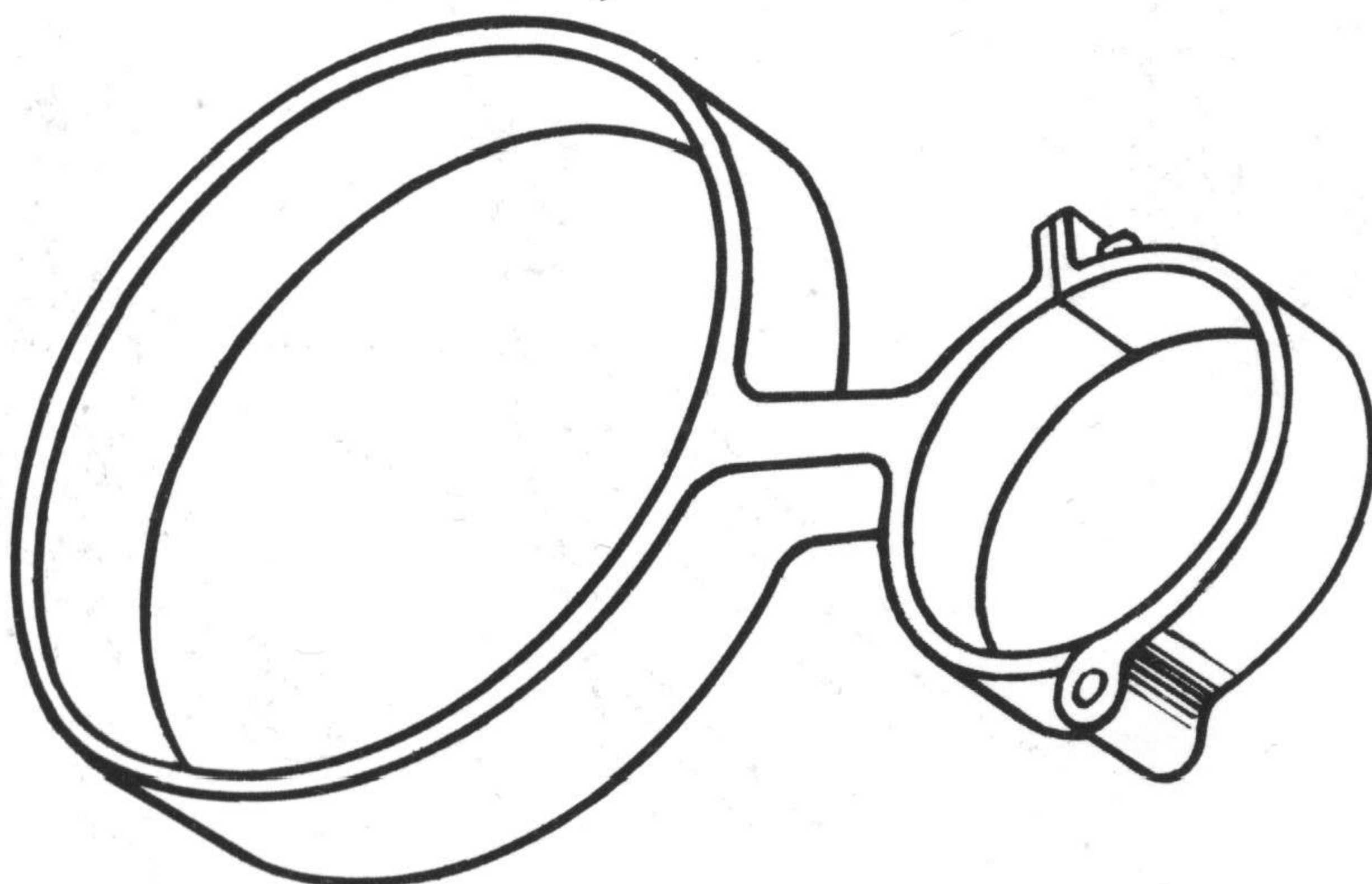
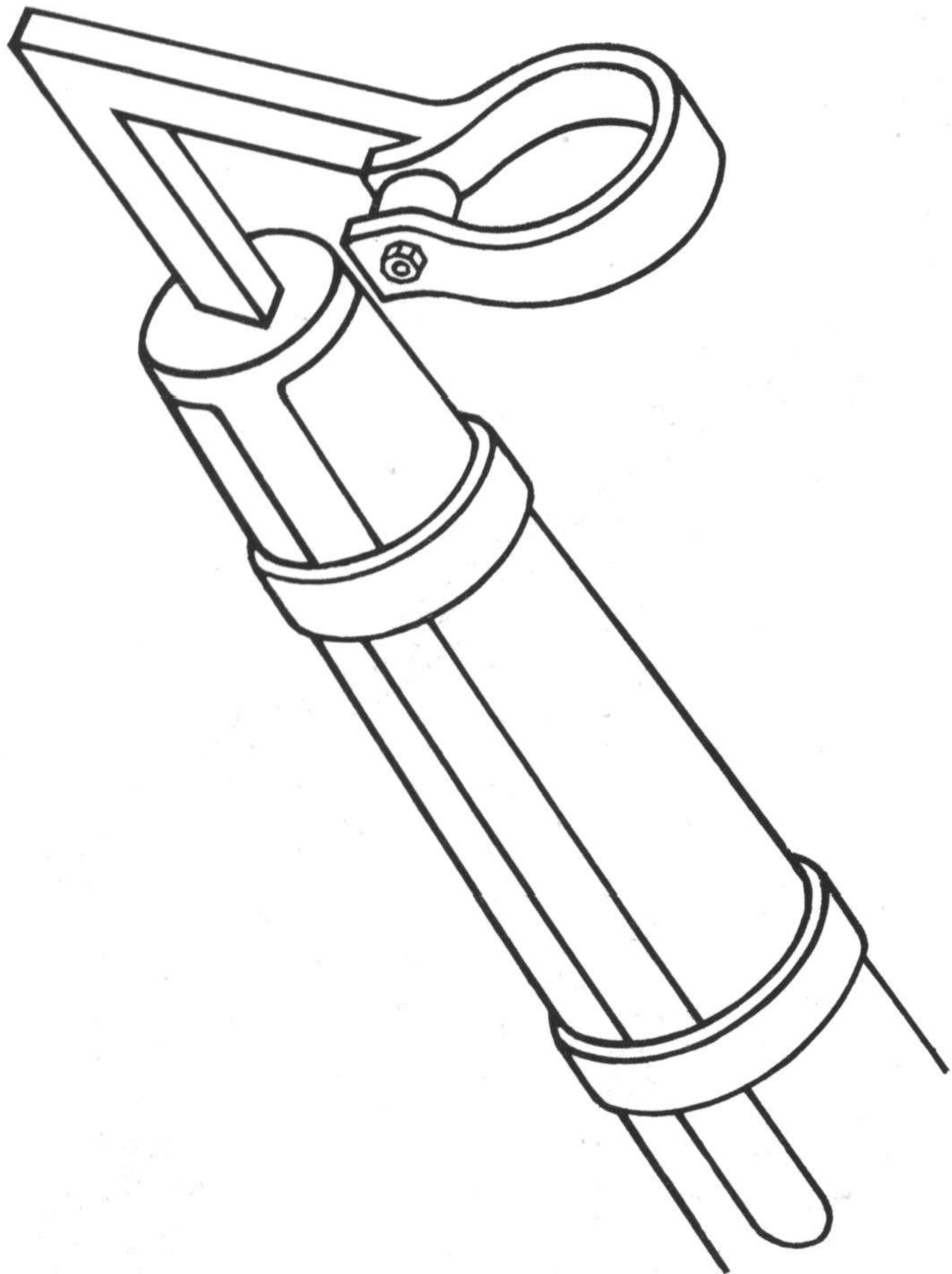

Fore Staysail

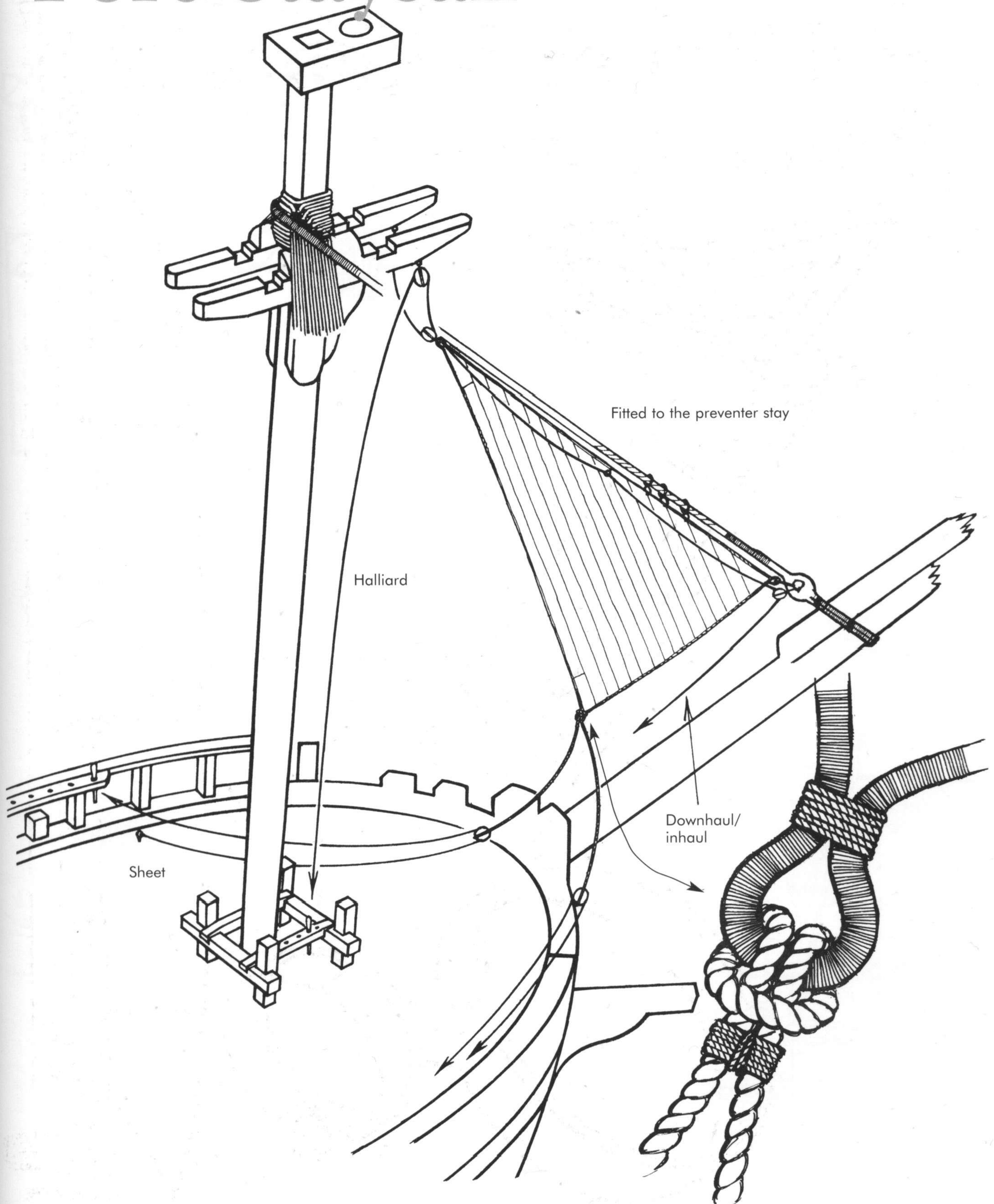

Main Staysail

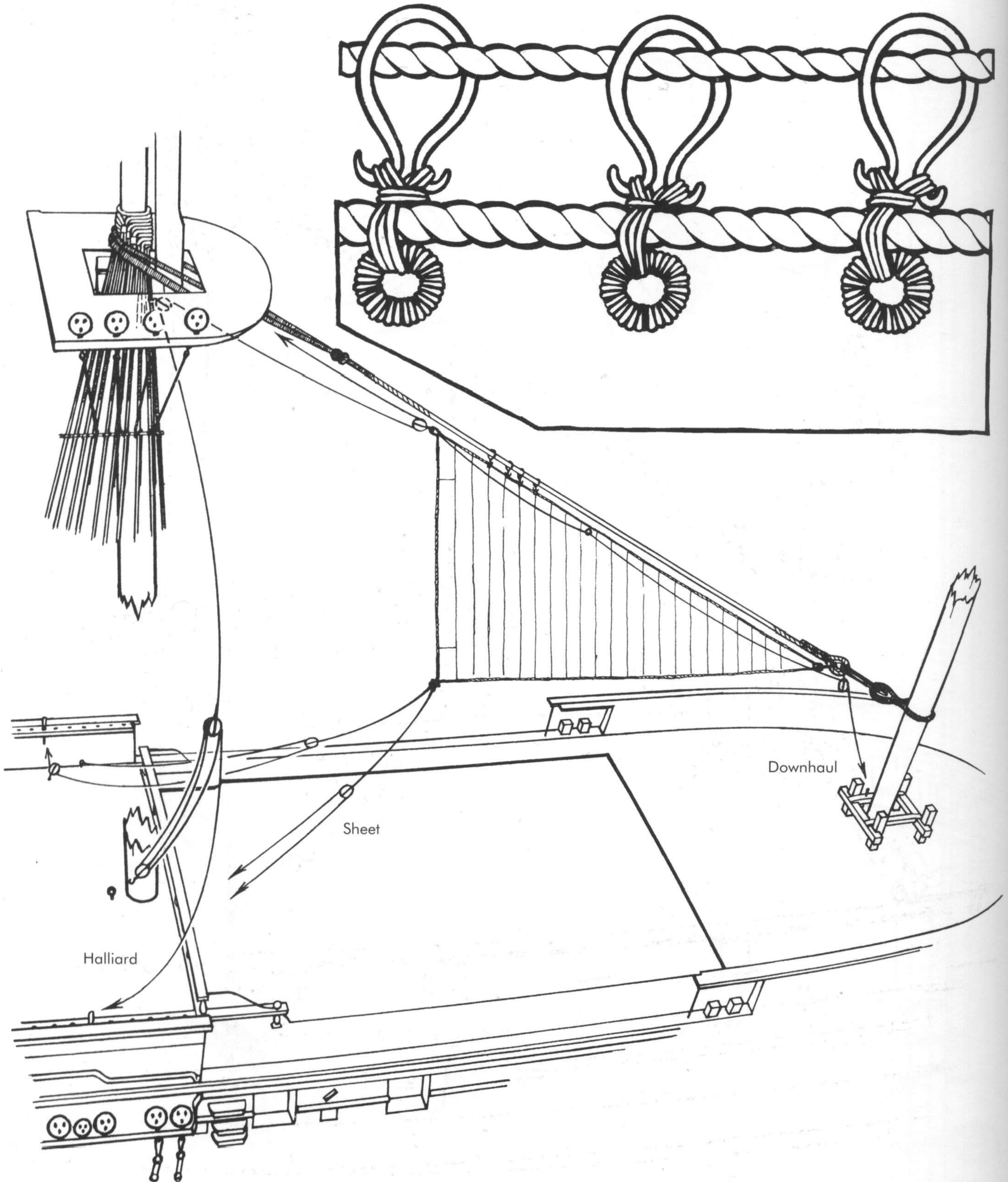

Mizzen Staysail

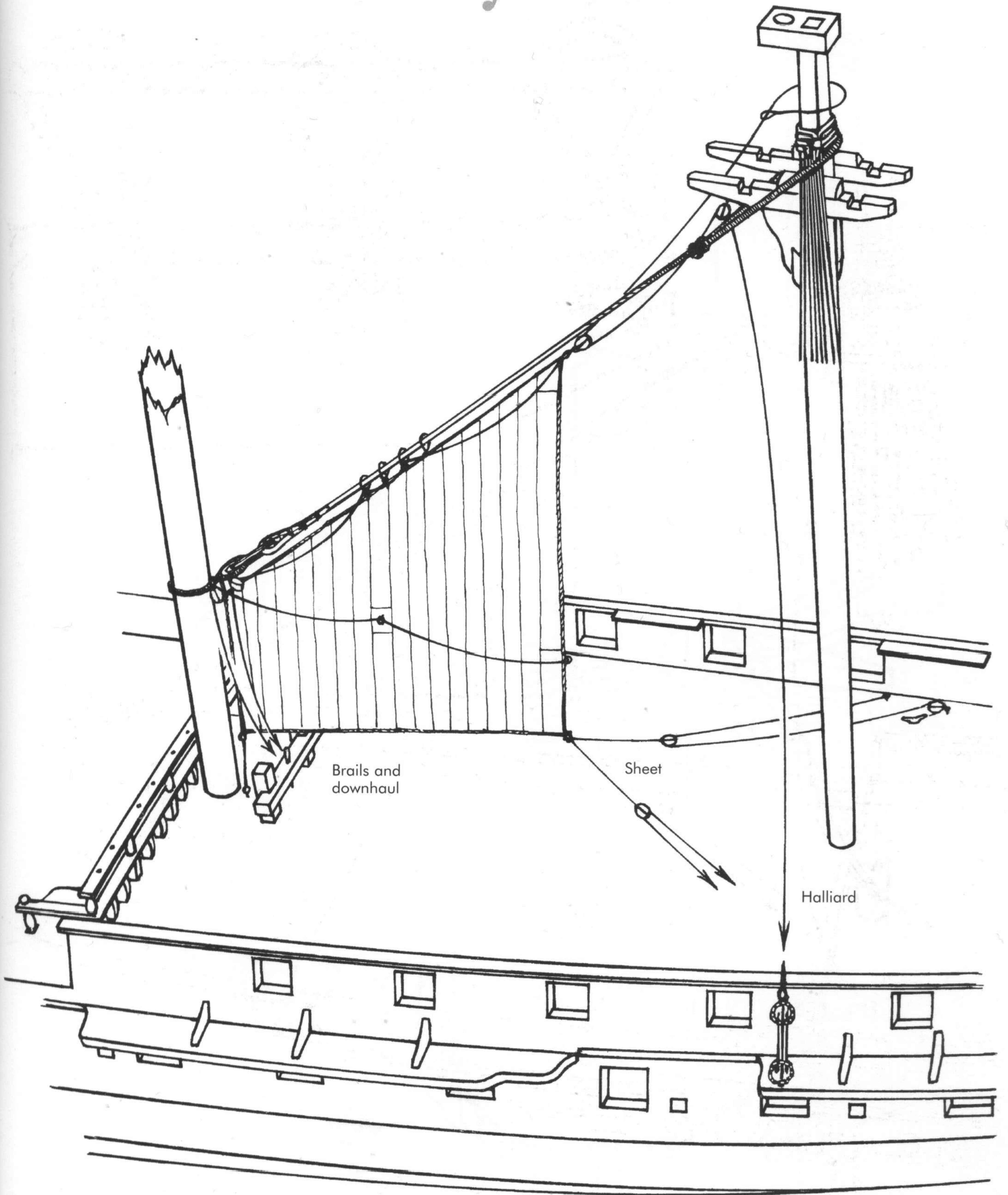

Fore Topmast Staysail Stay

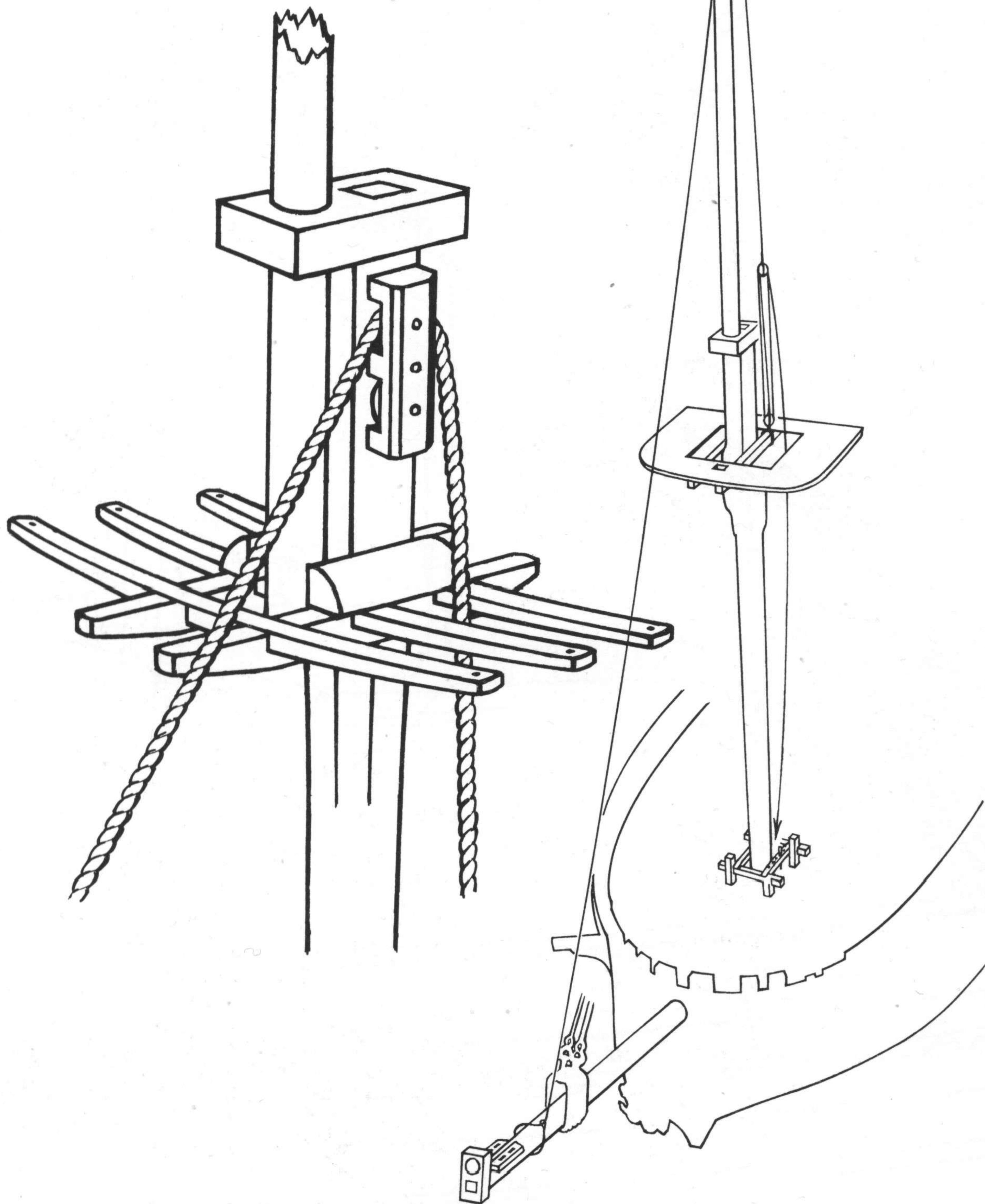

Fore Topmast Staysail

Bowsprit netting
A netting was required to keep the sail clear of the bowsprit when furled

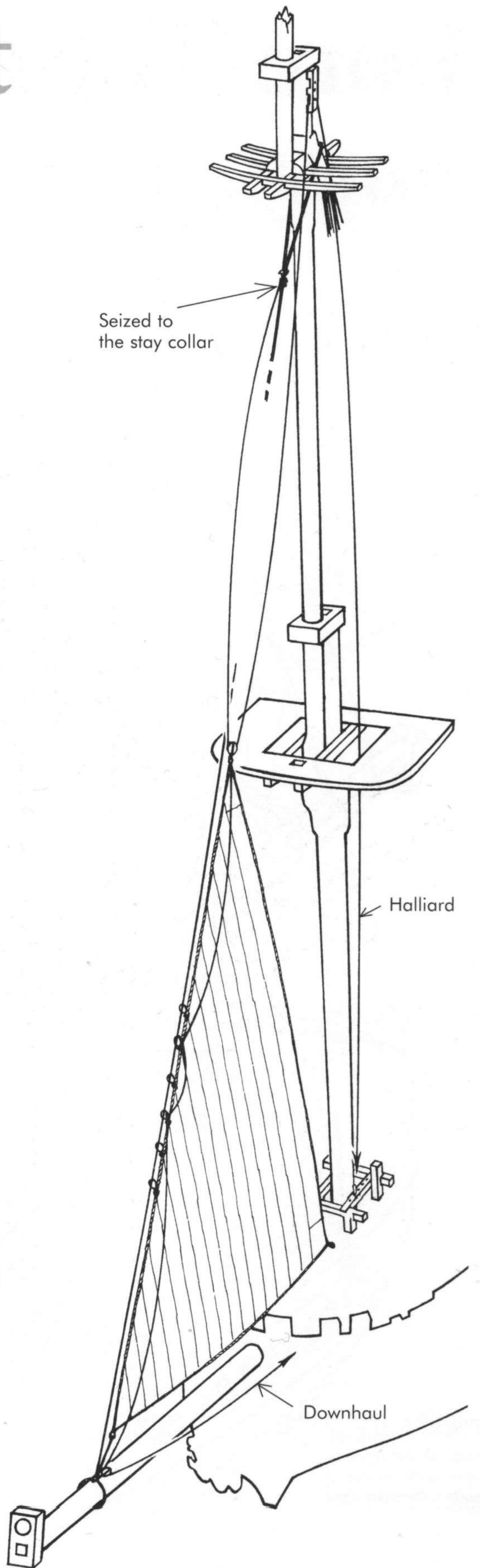
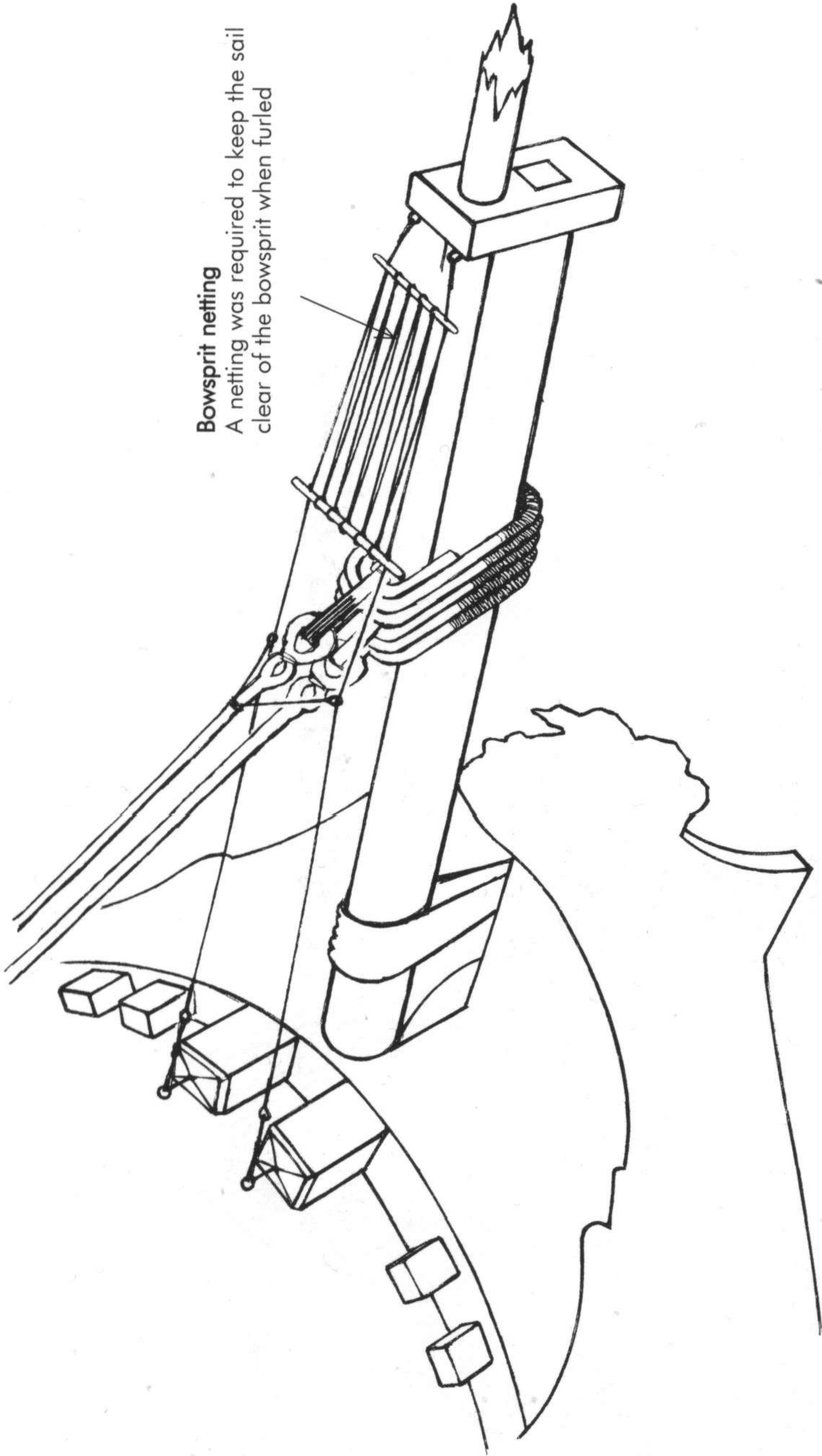

Fore Topmast Staysail

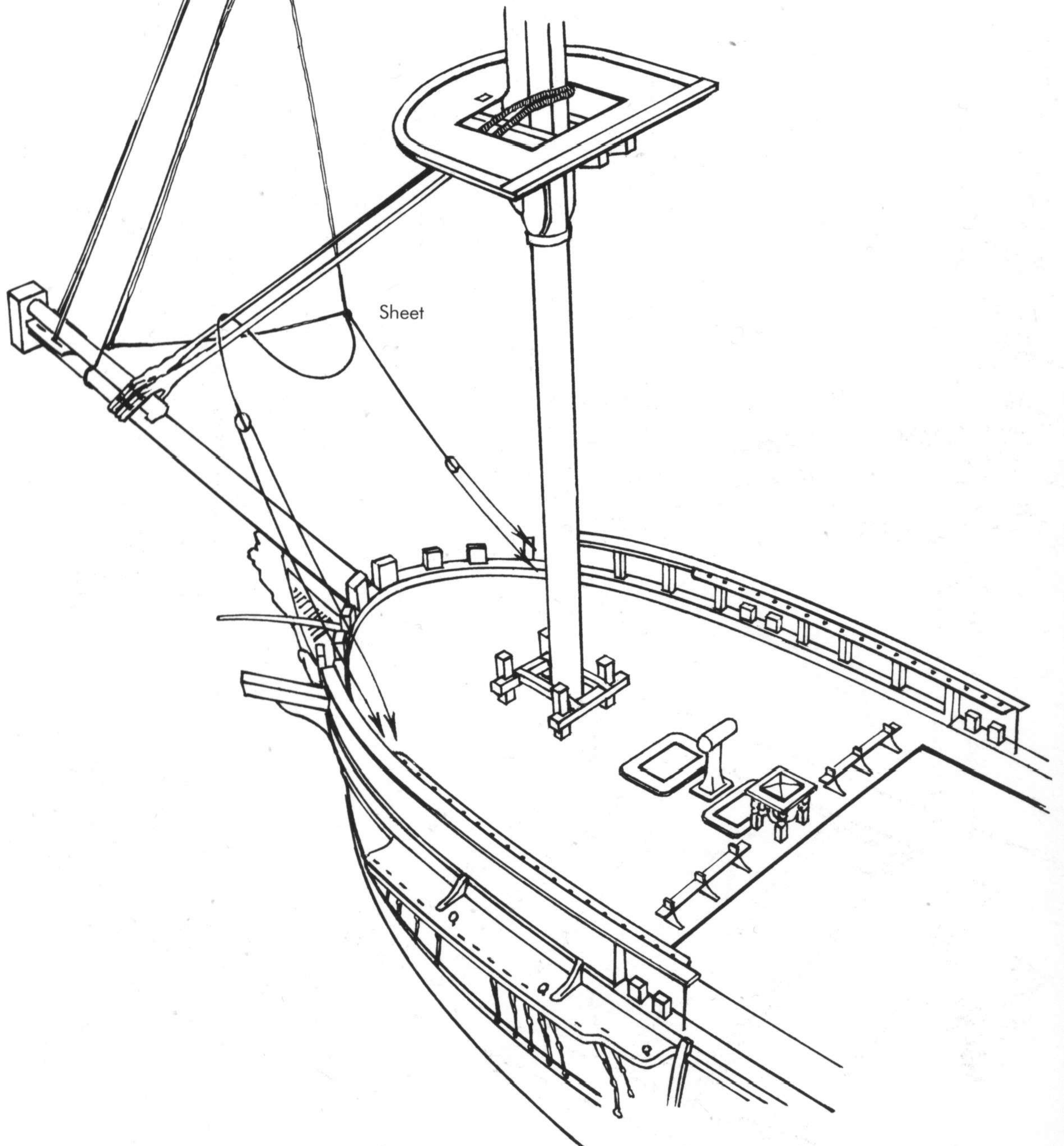

Main Topmast Staysail

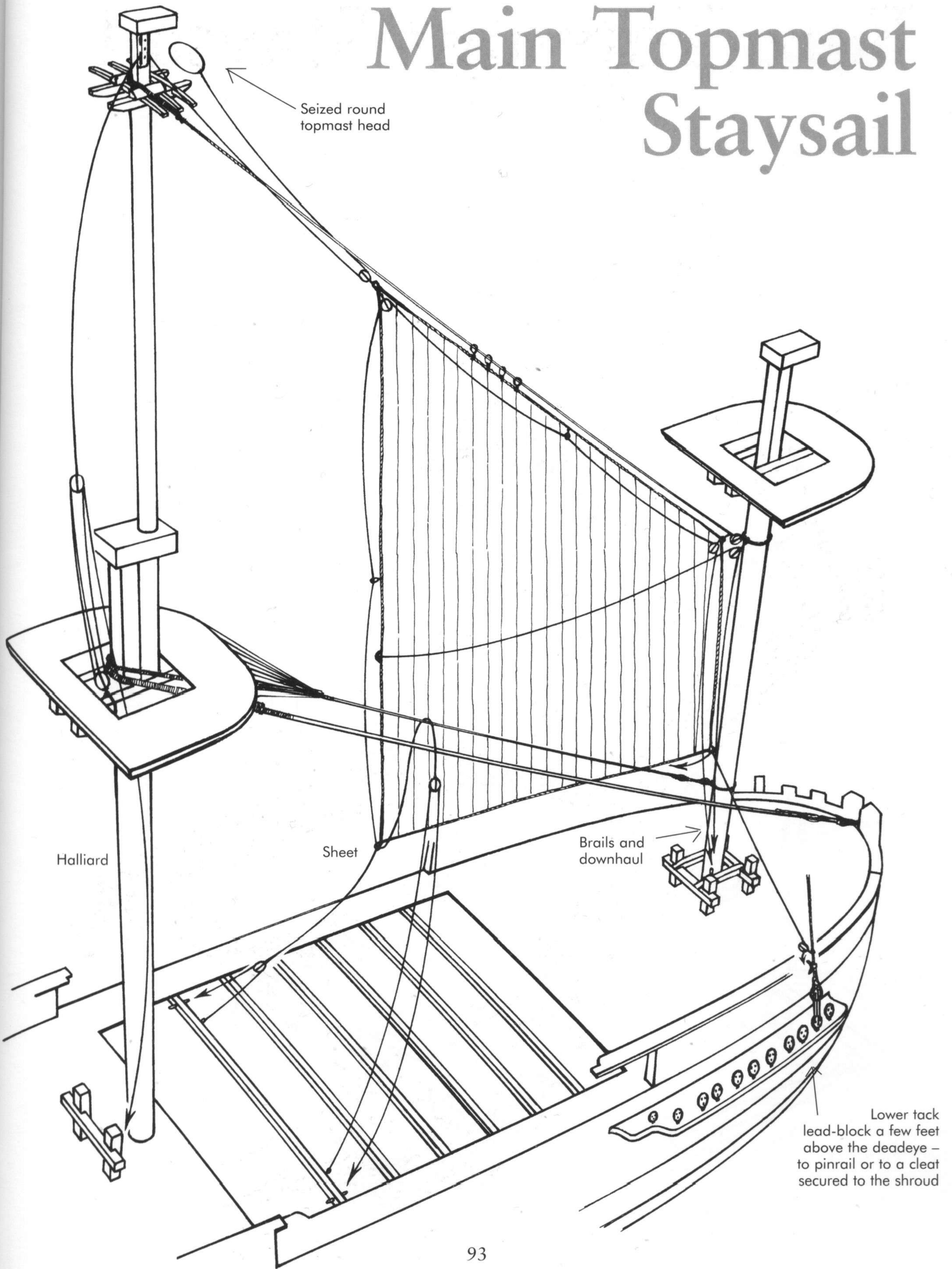

Mizzen Topmast Staysail

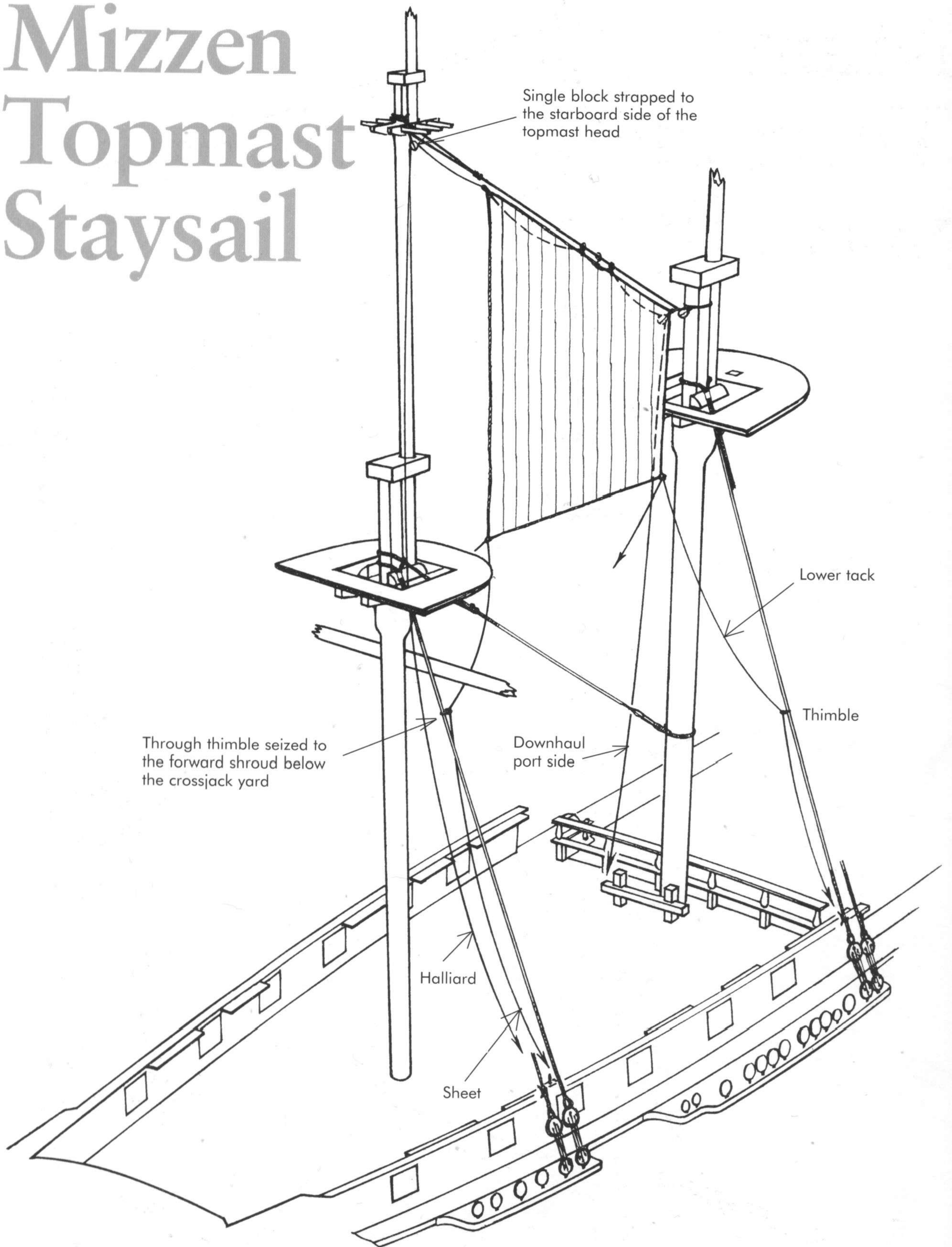

Main Topgallant Staysail

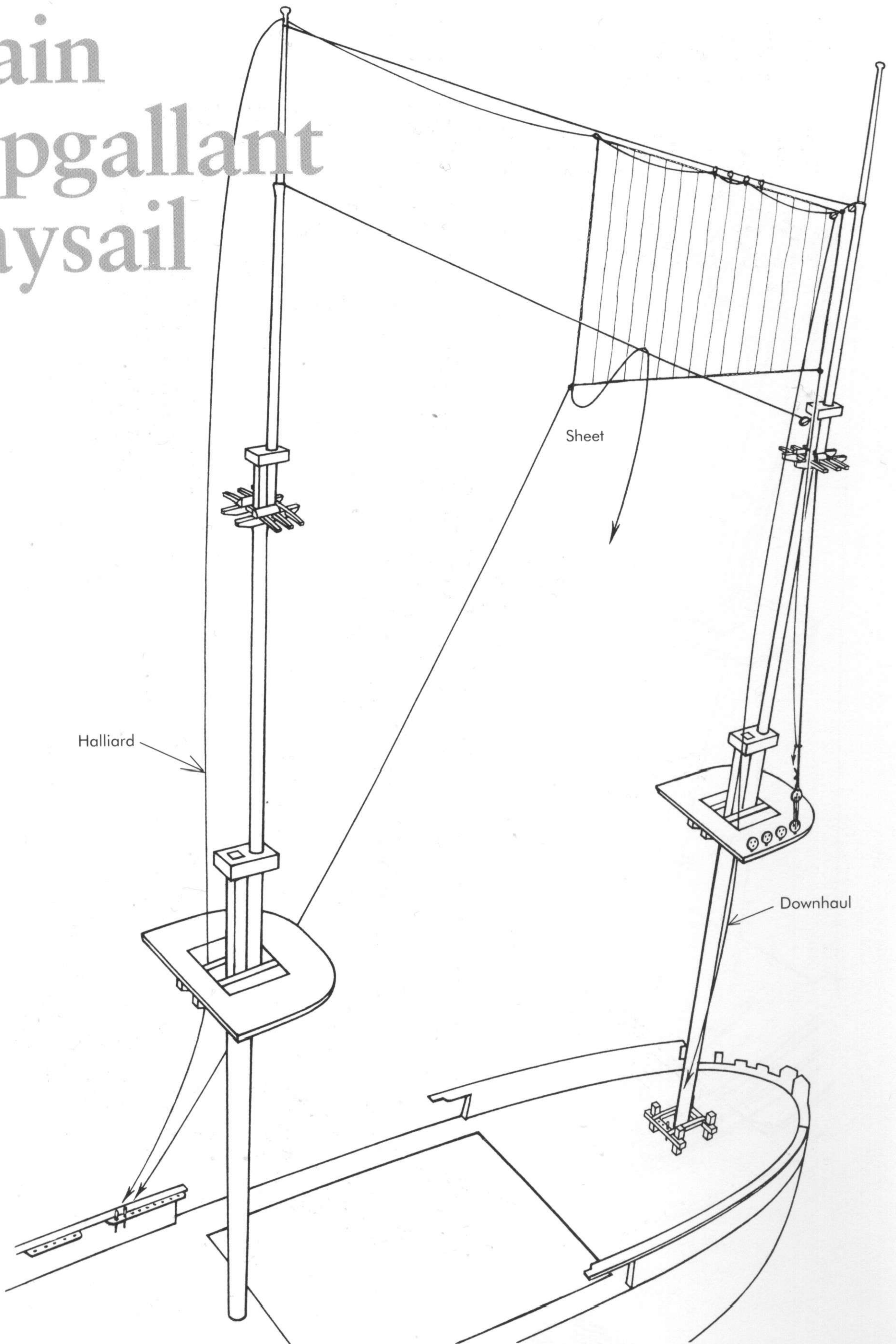

Jib

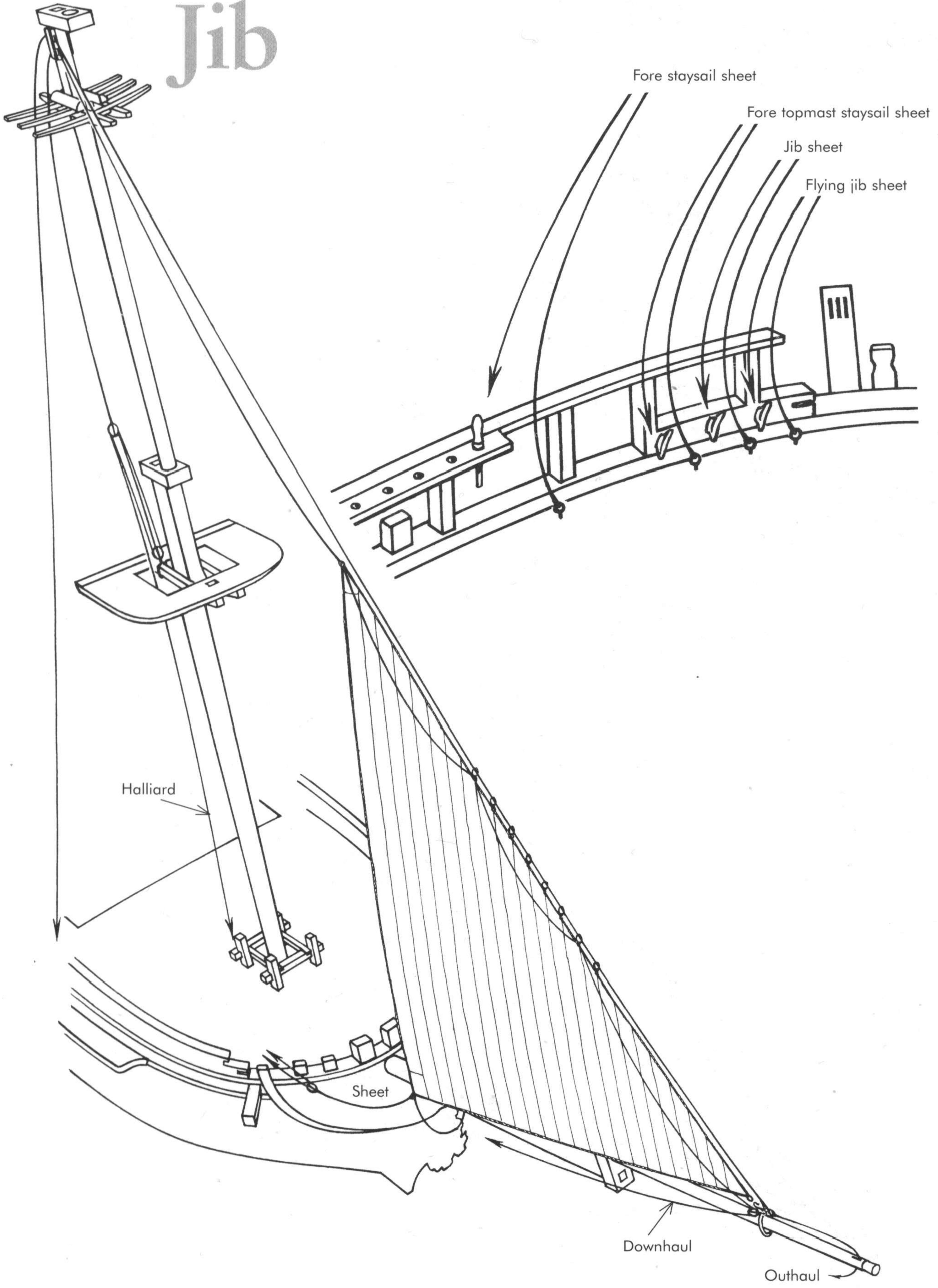

Flying Jib

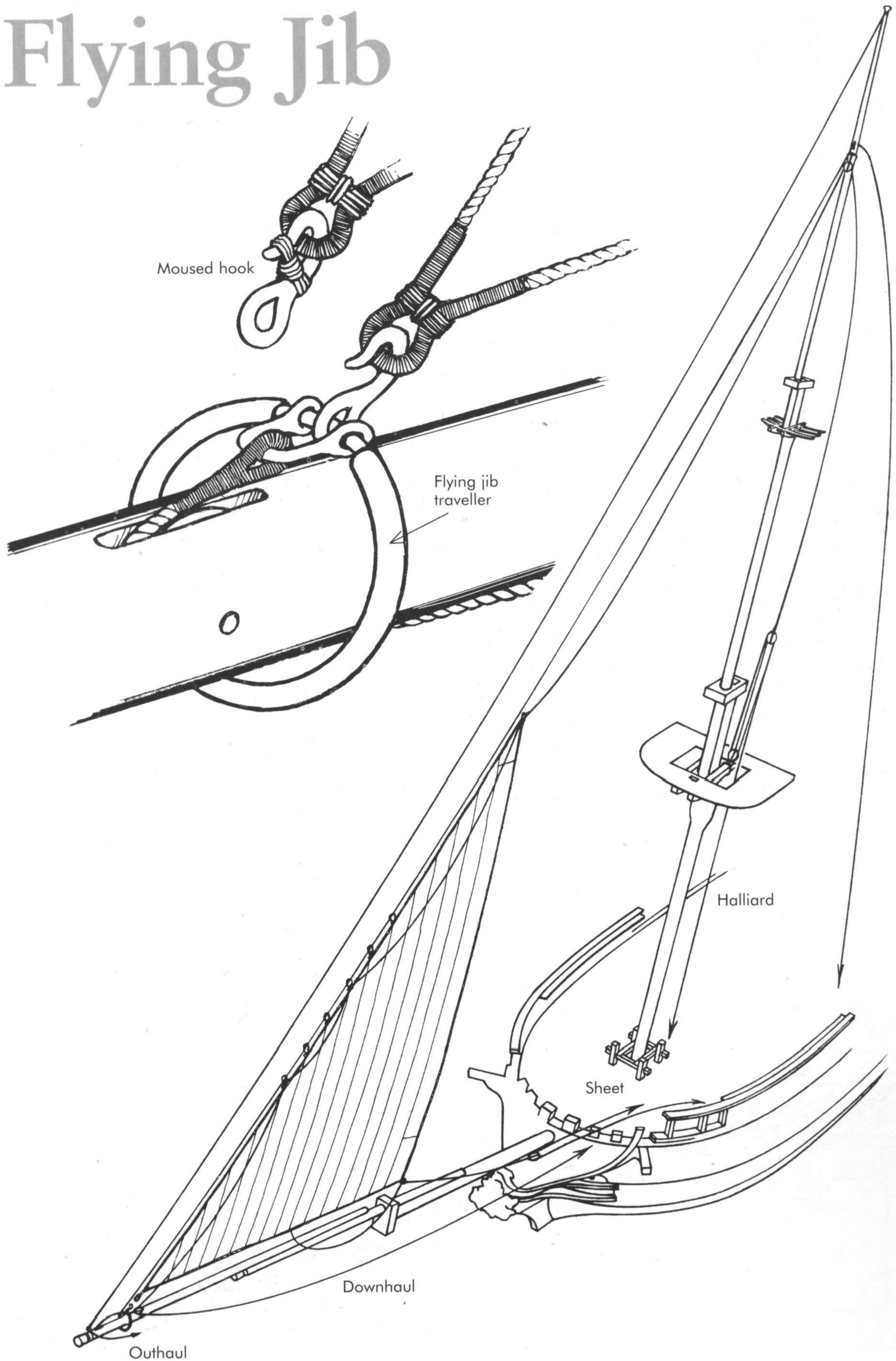

Belaying Plan A

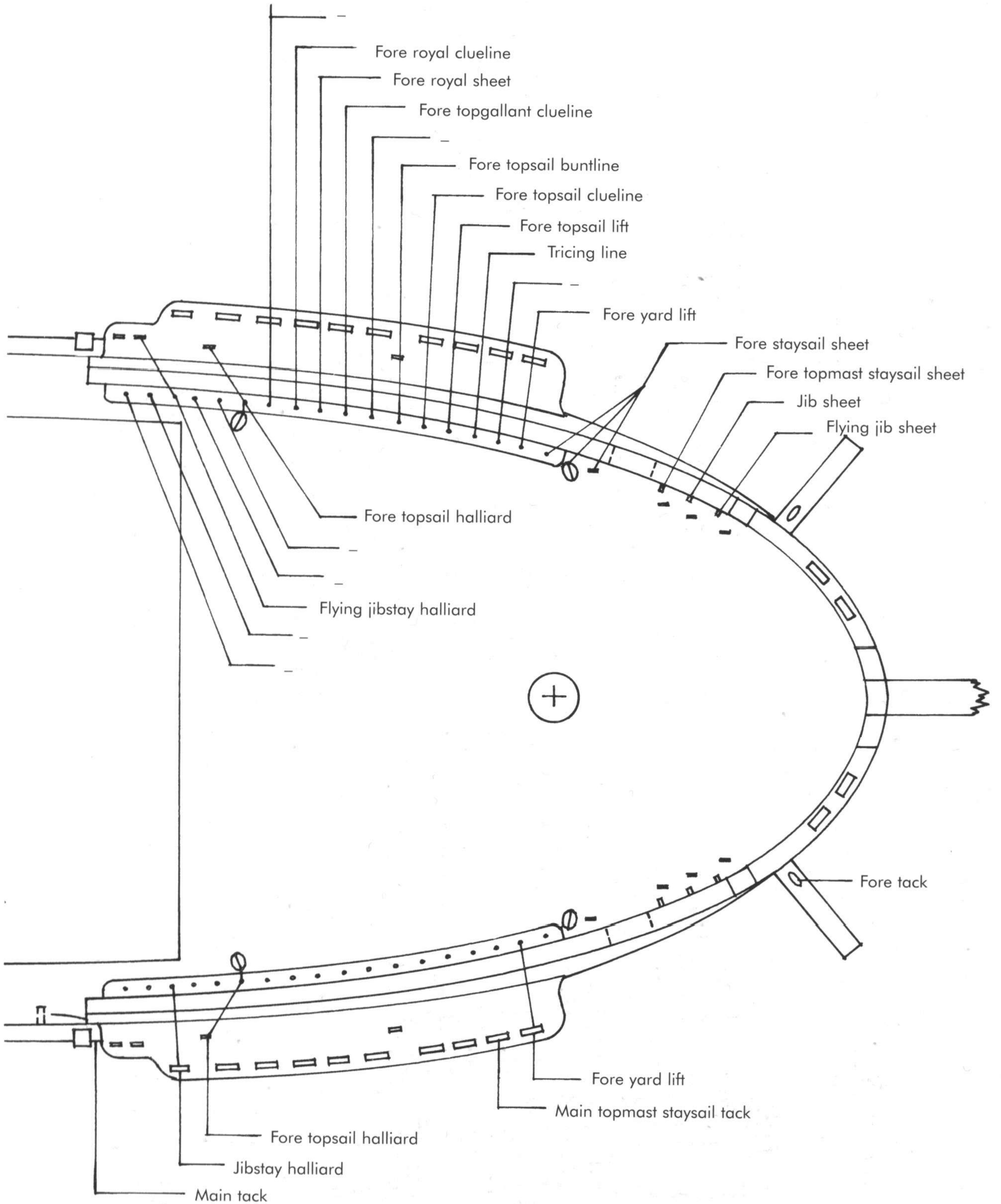

Belaying Plan B

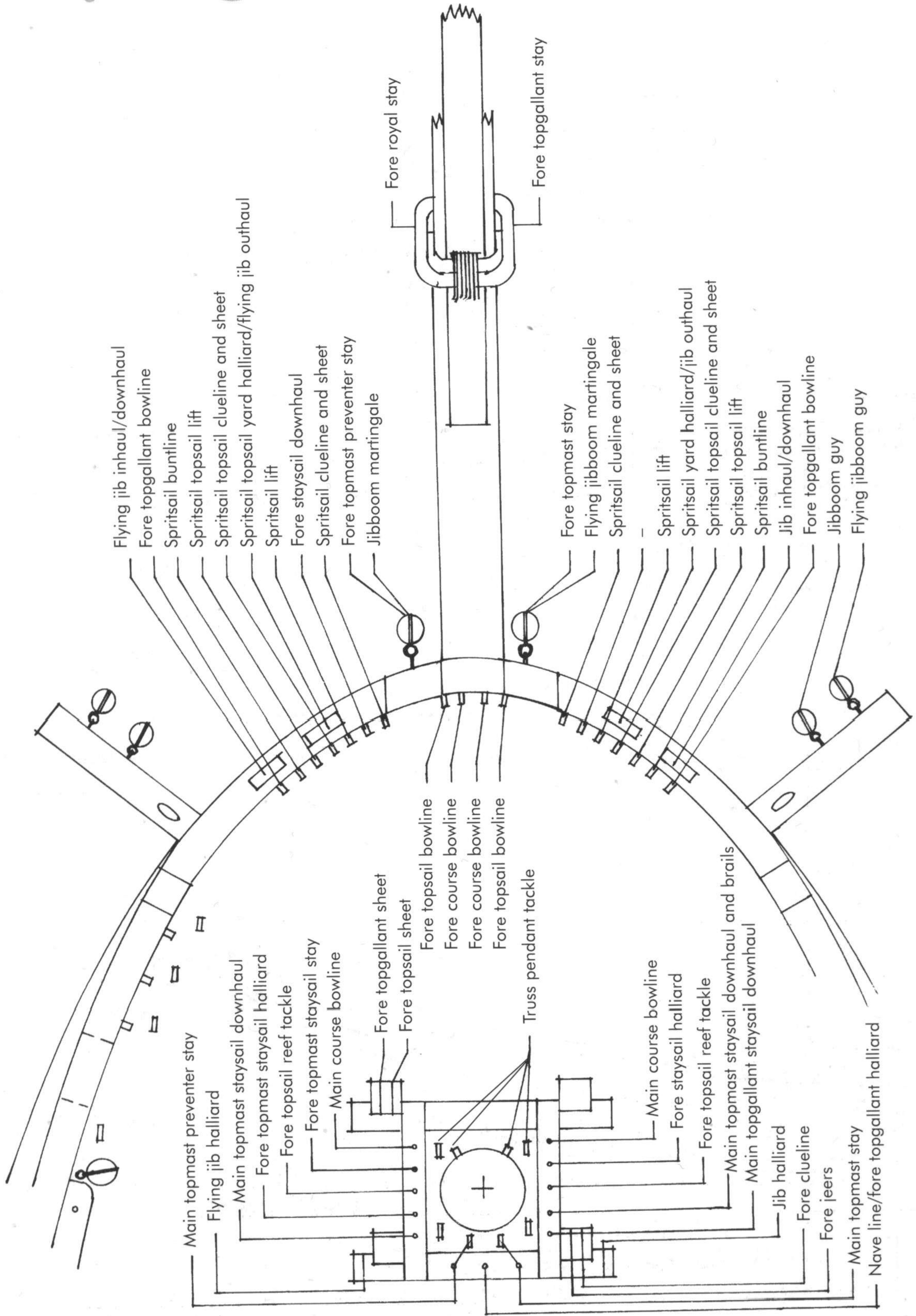

Belaying Plan C

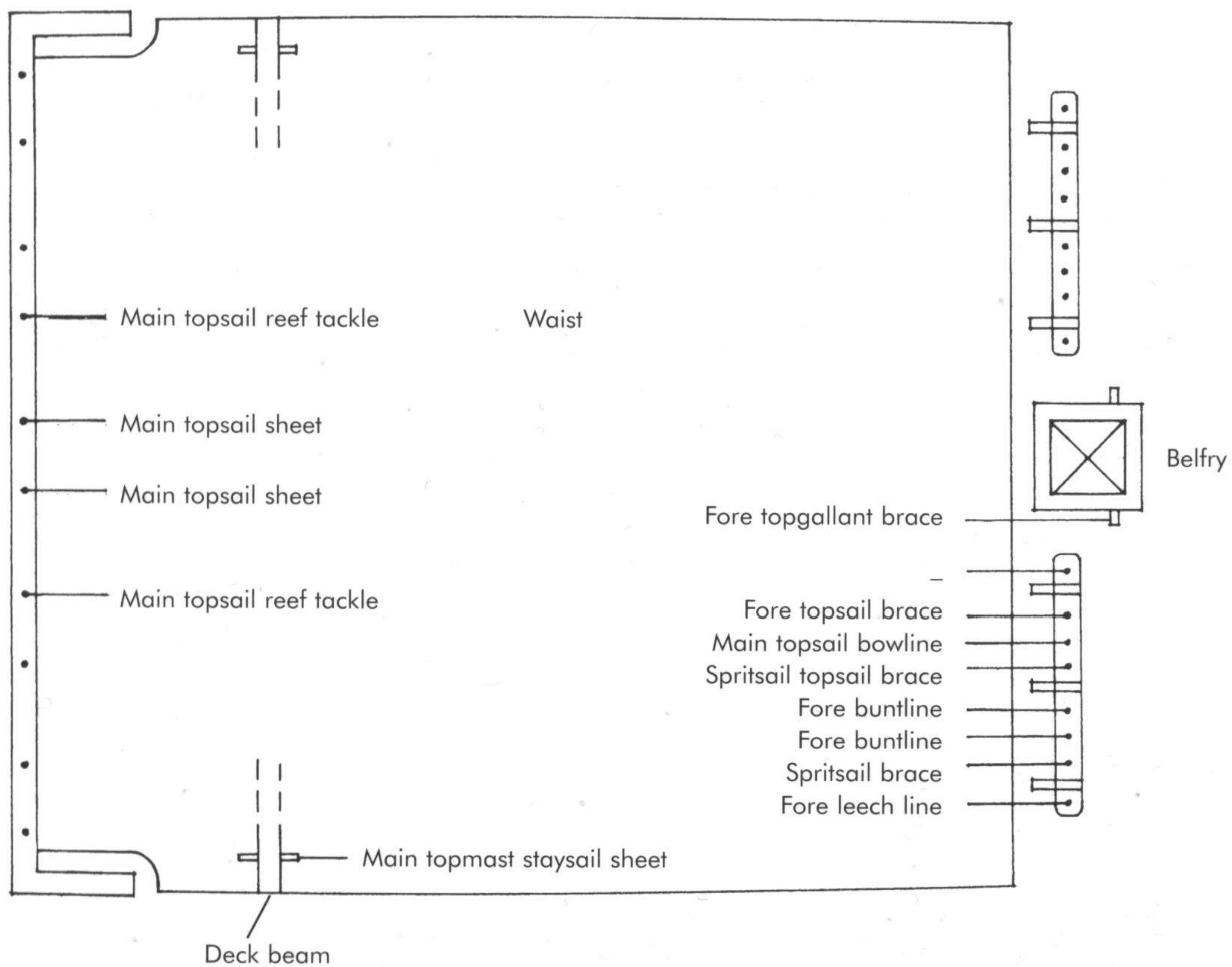
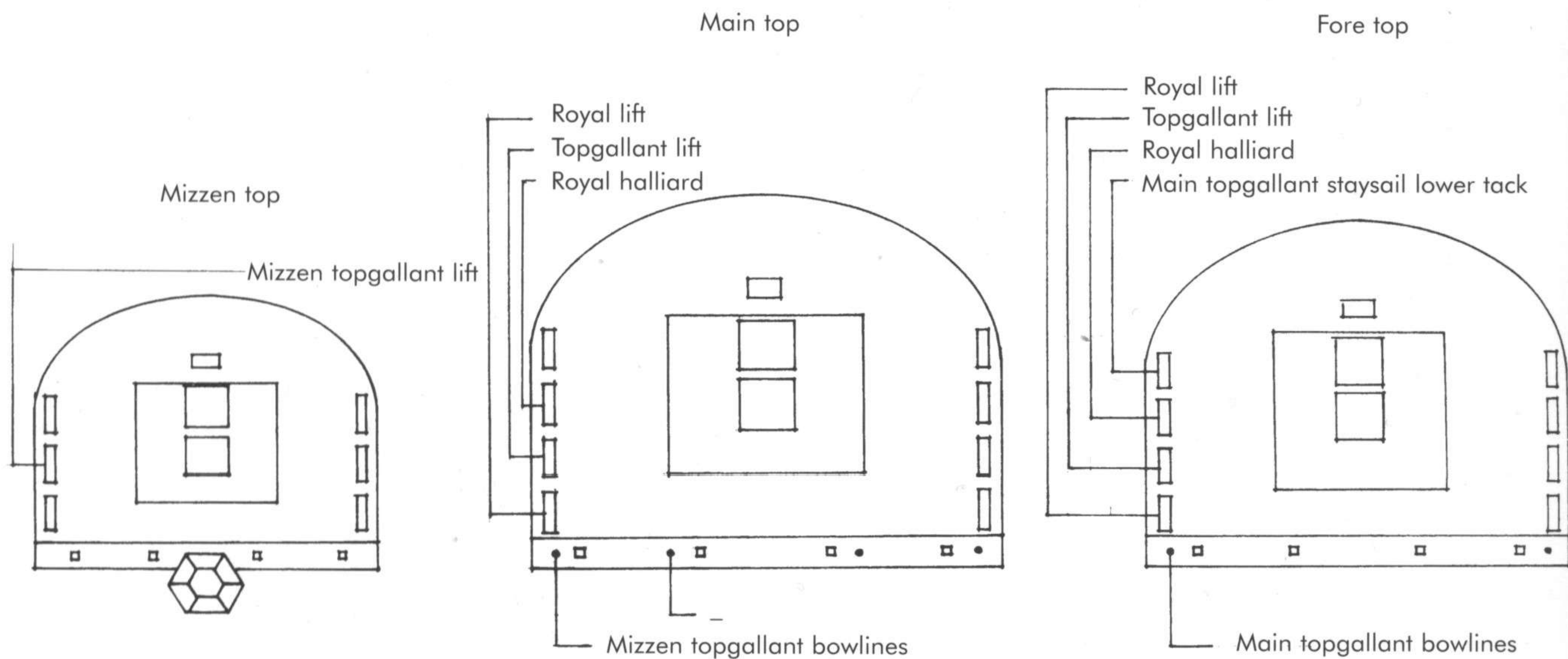

Cross-section

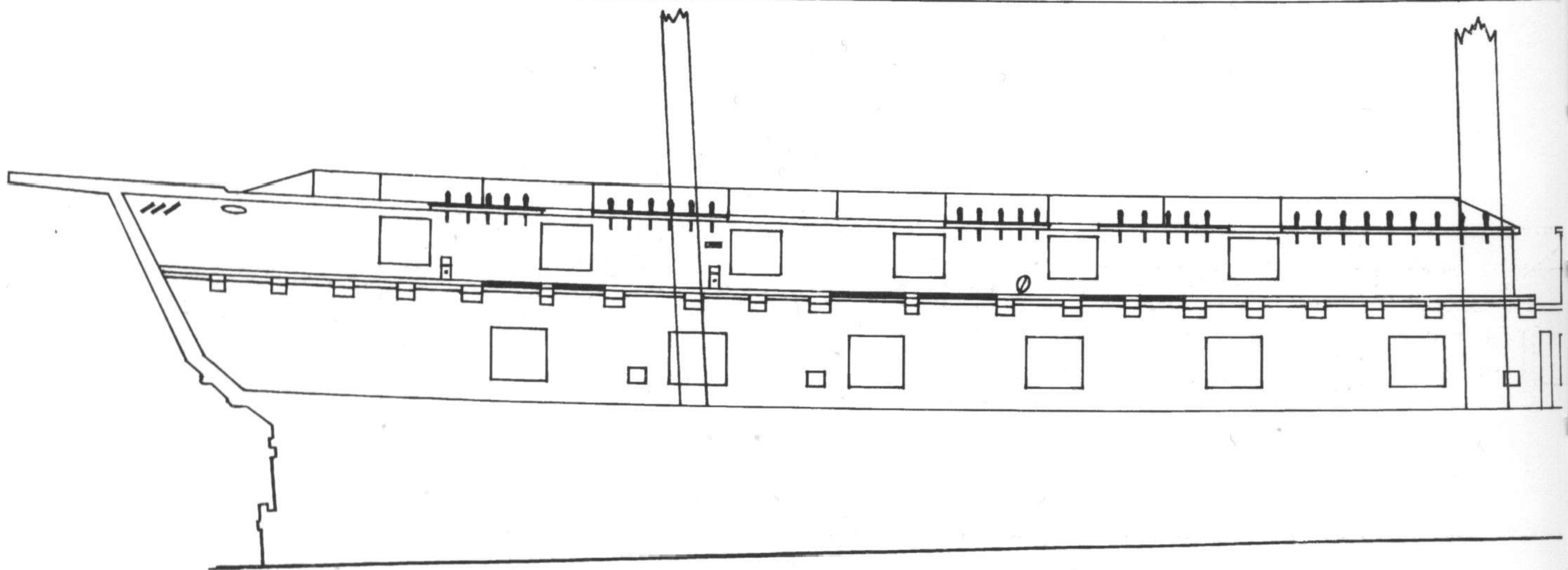
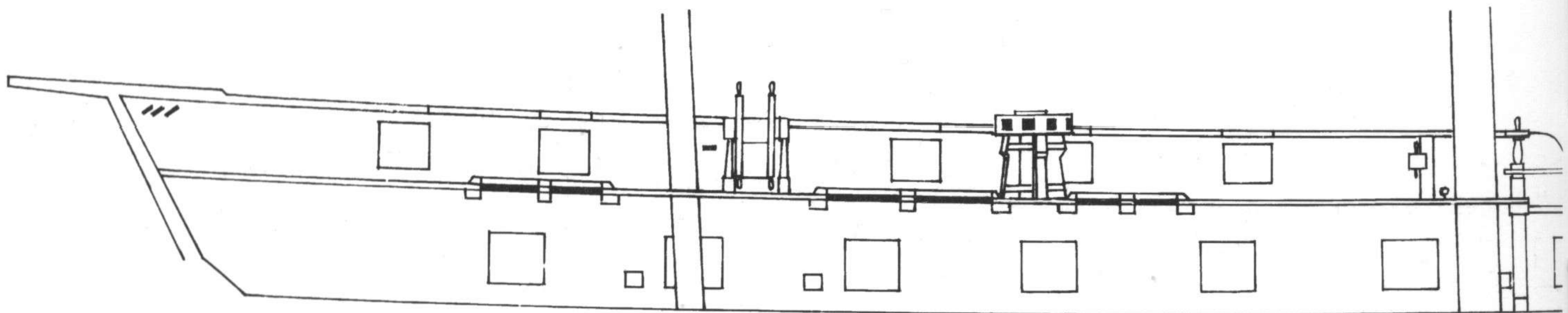
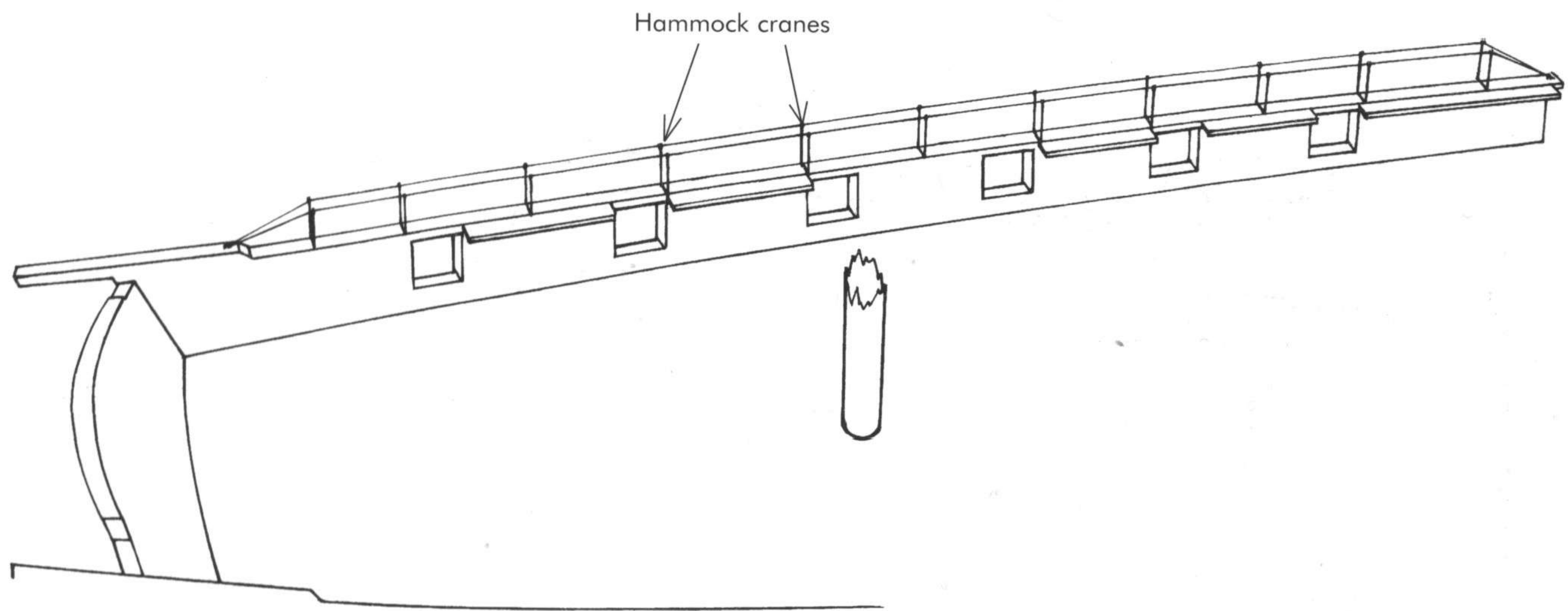

Hammock cranes

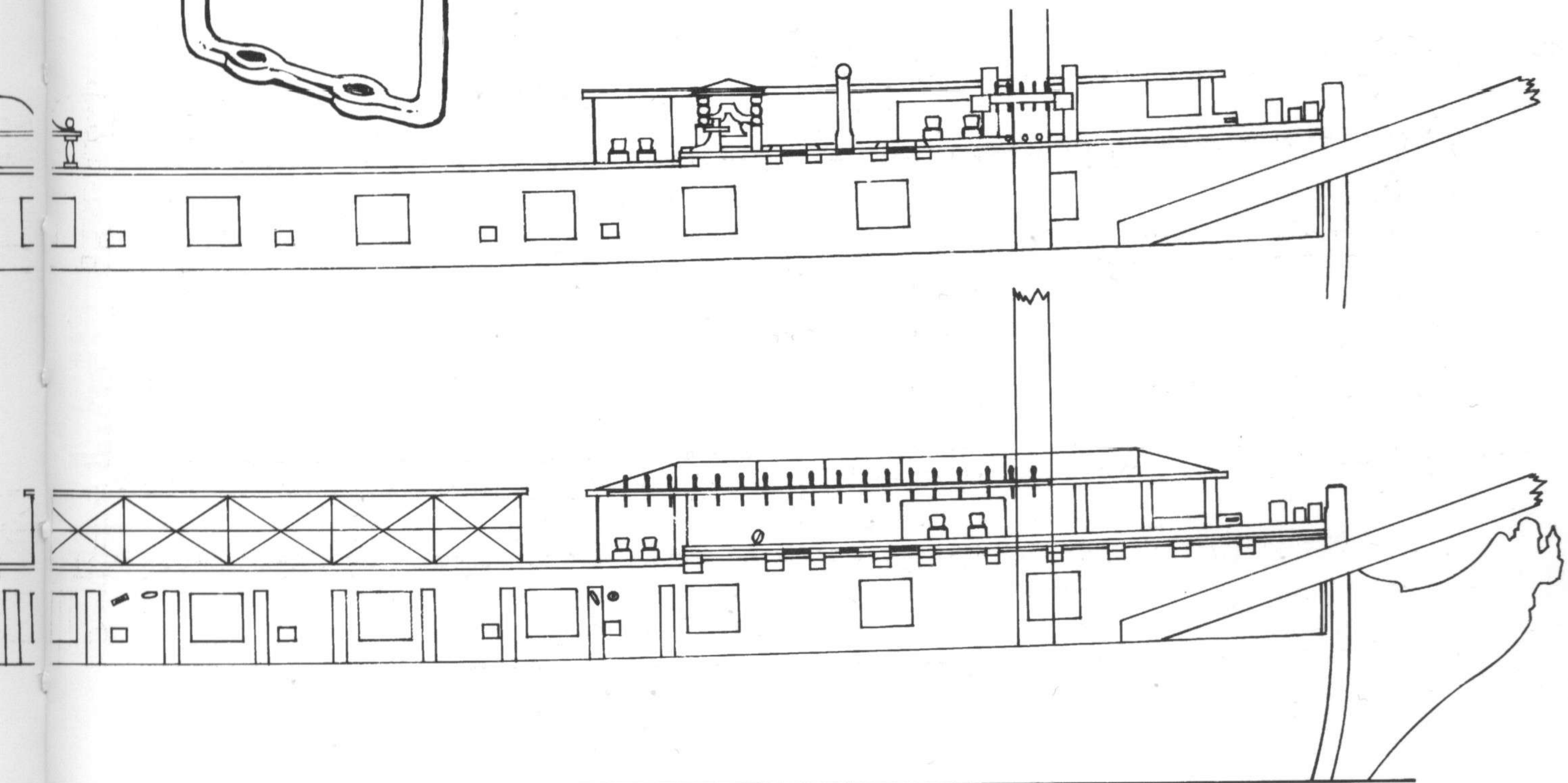
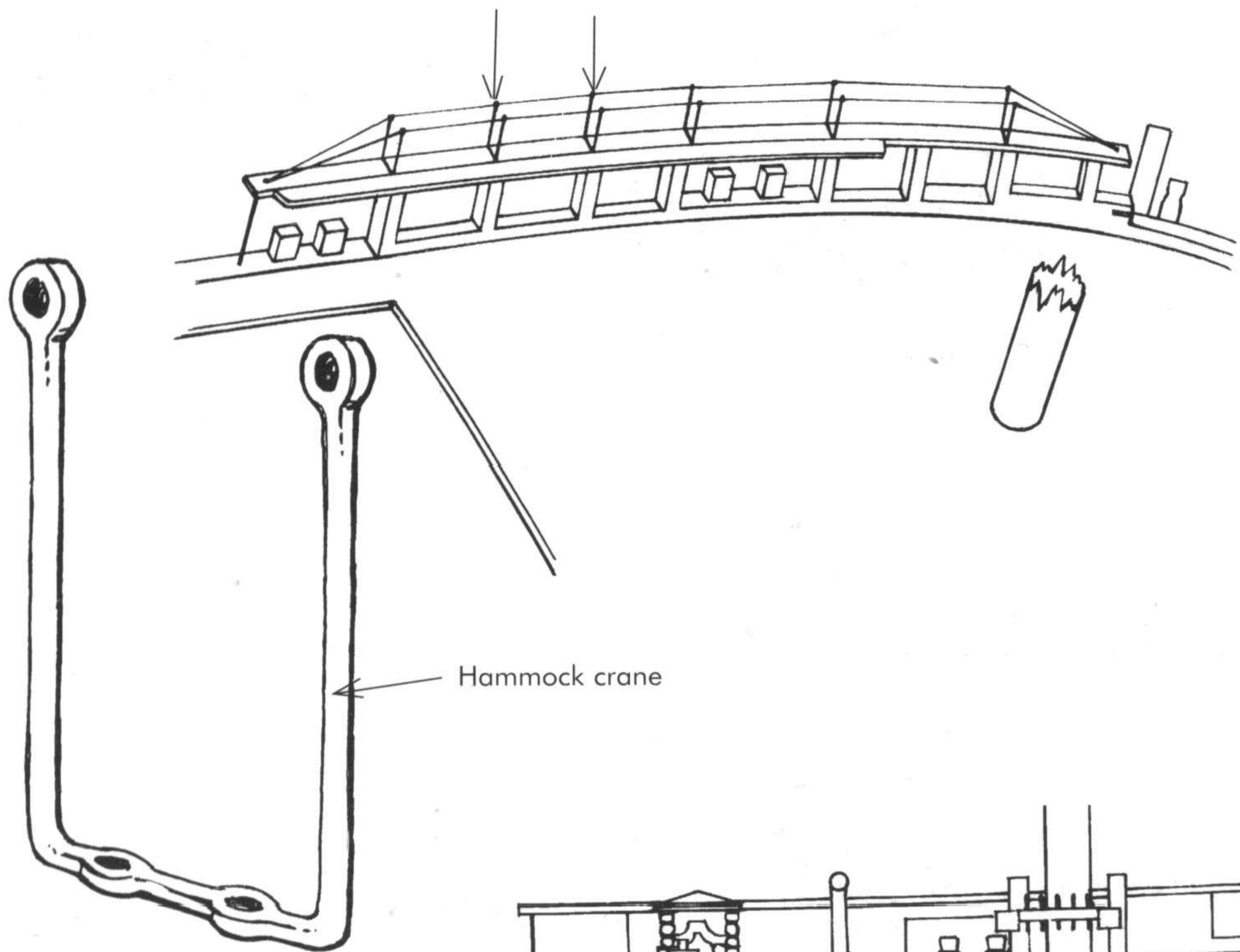

External Hull

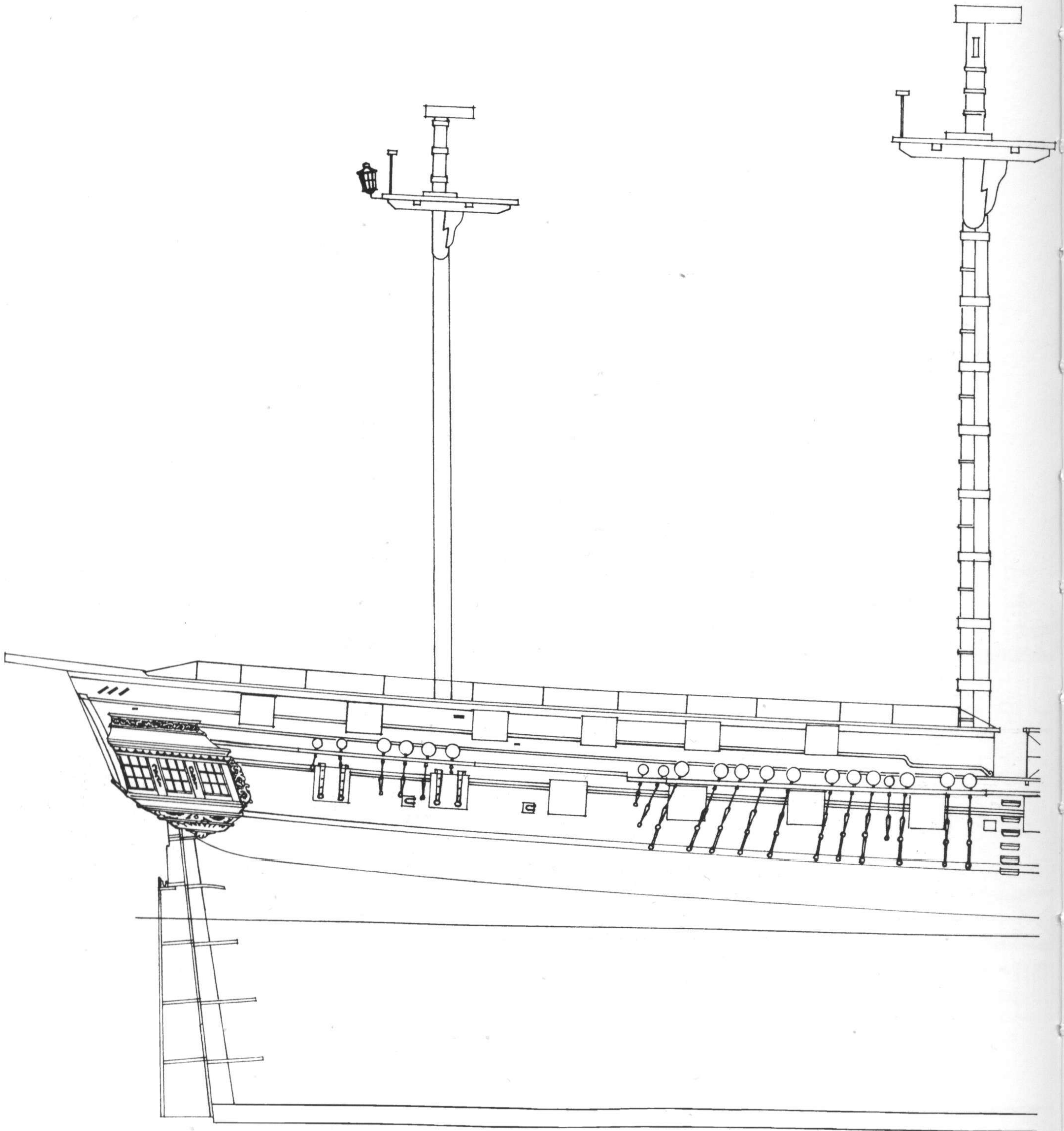

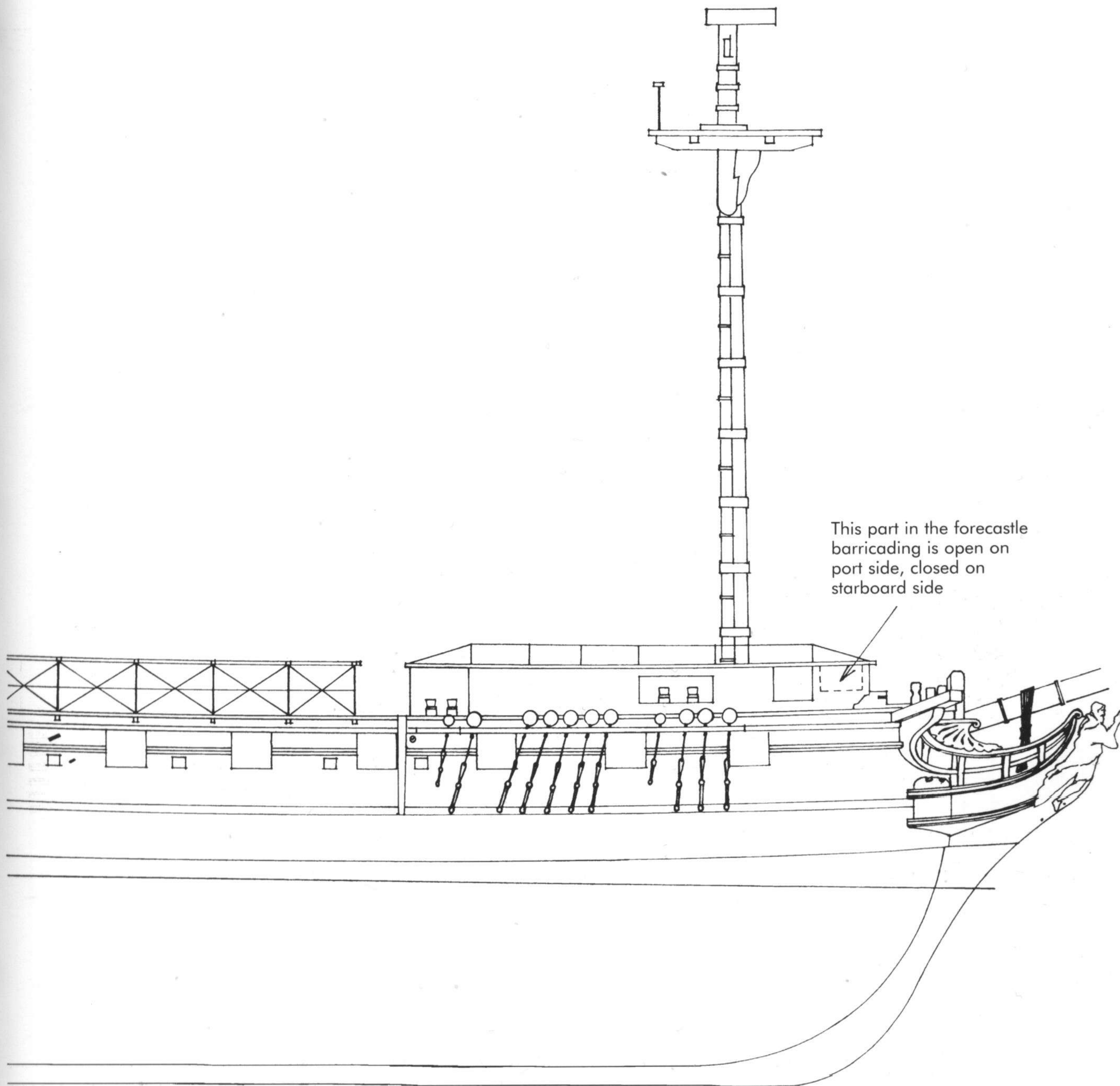

Square Sails

see studding sails page 108

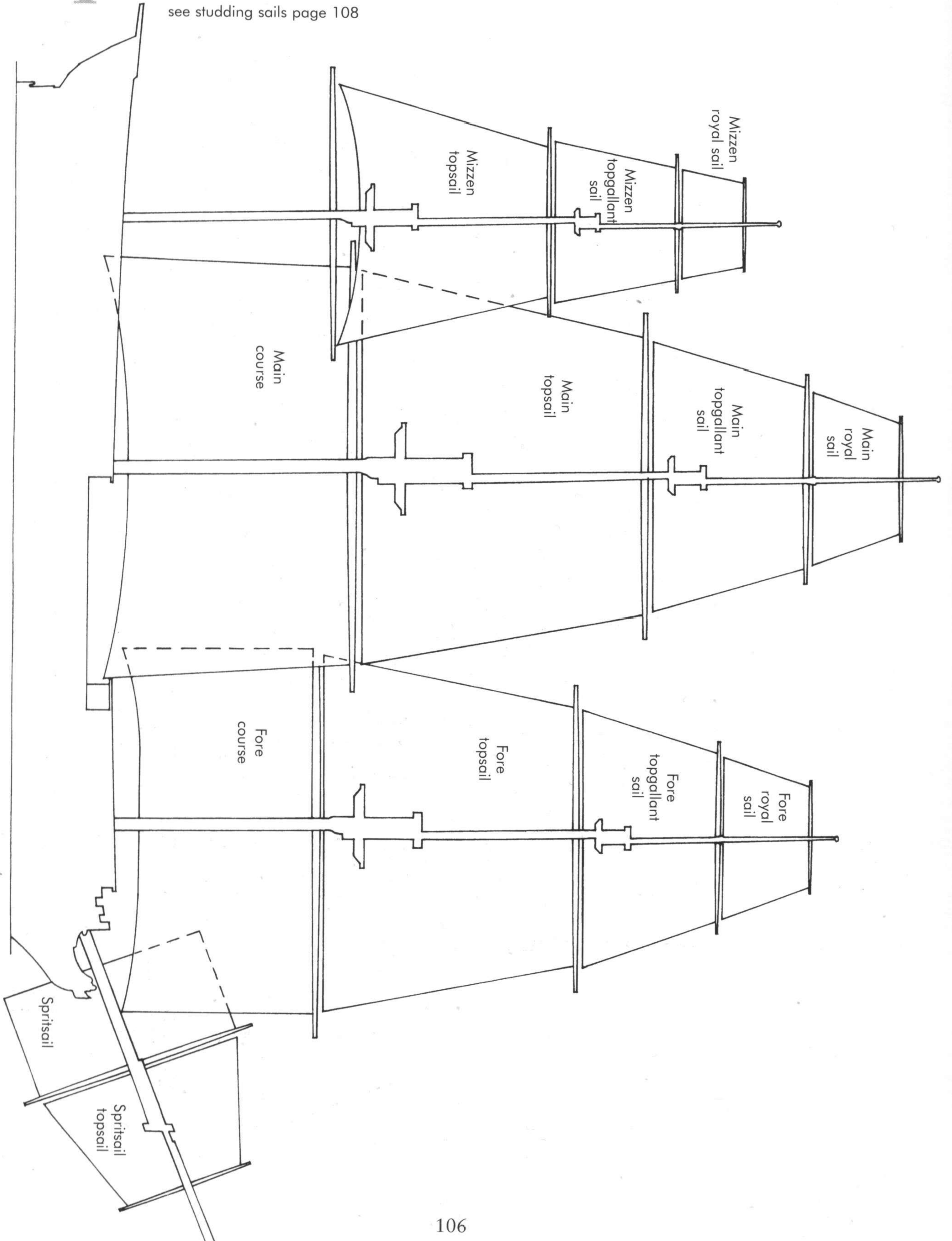

Fore and aft Sails

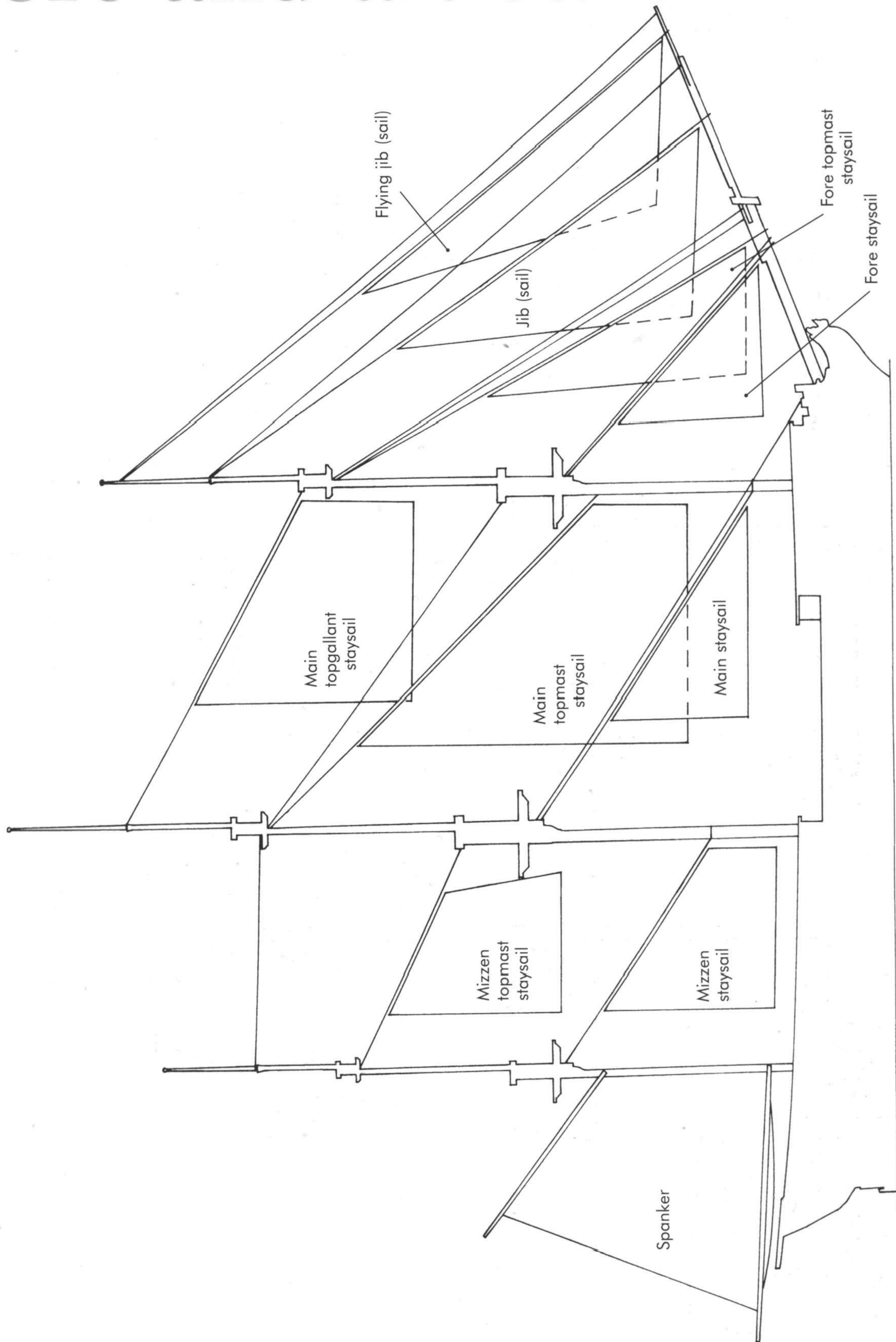

Studding Sails

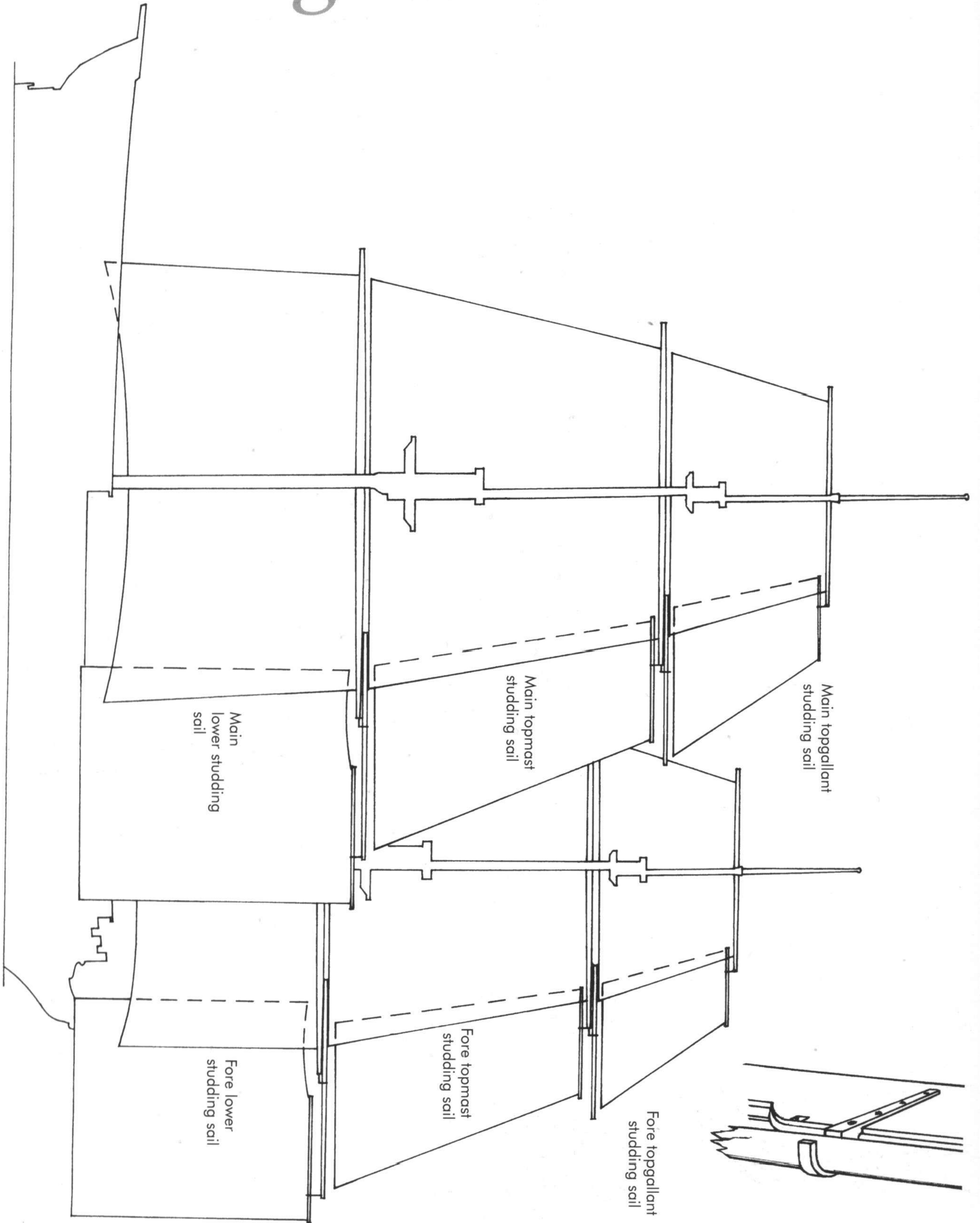

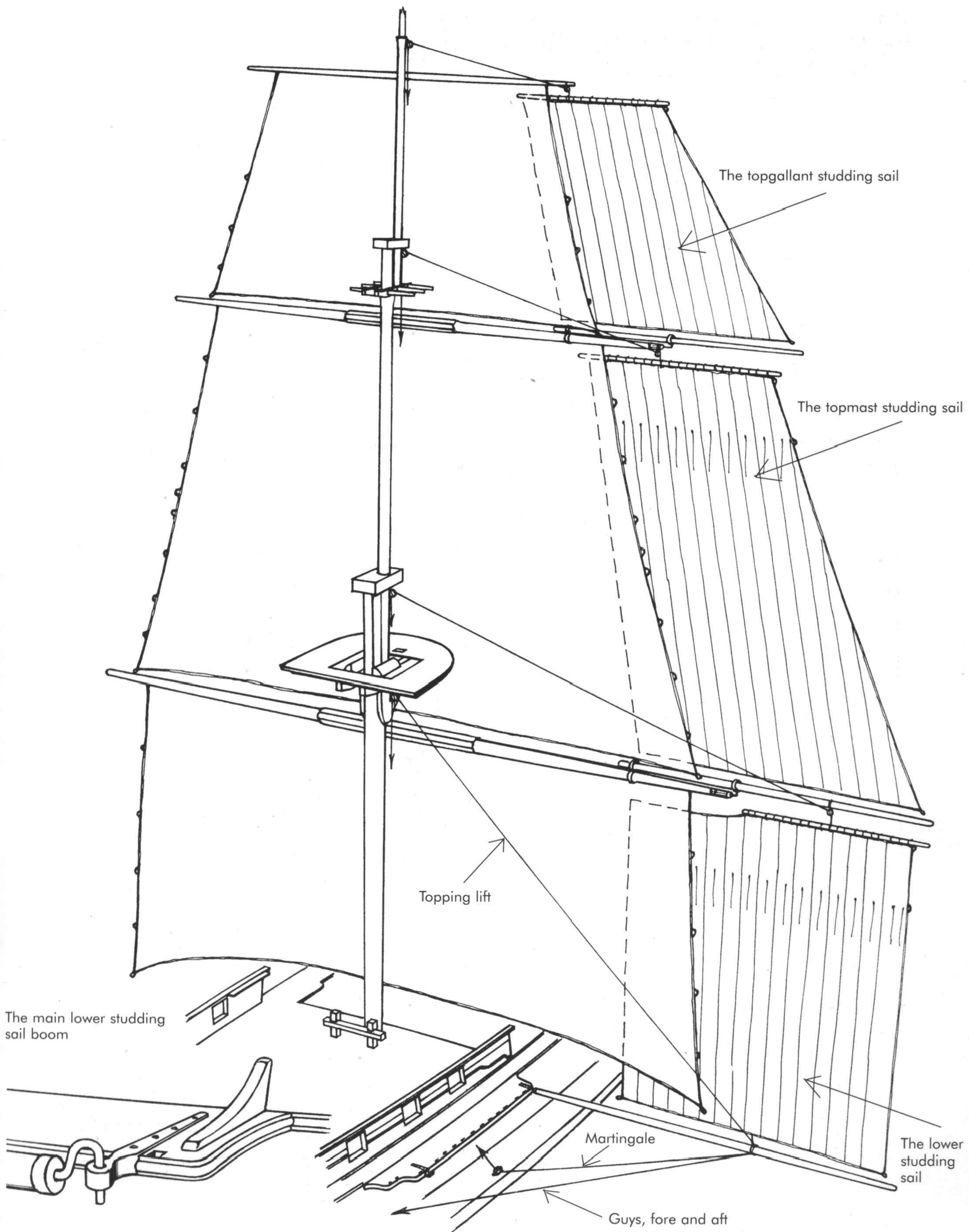

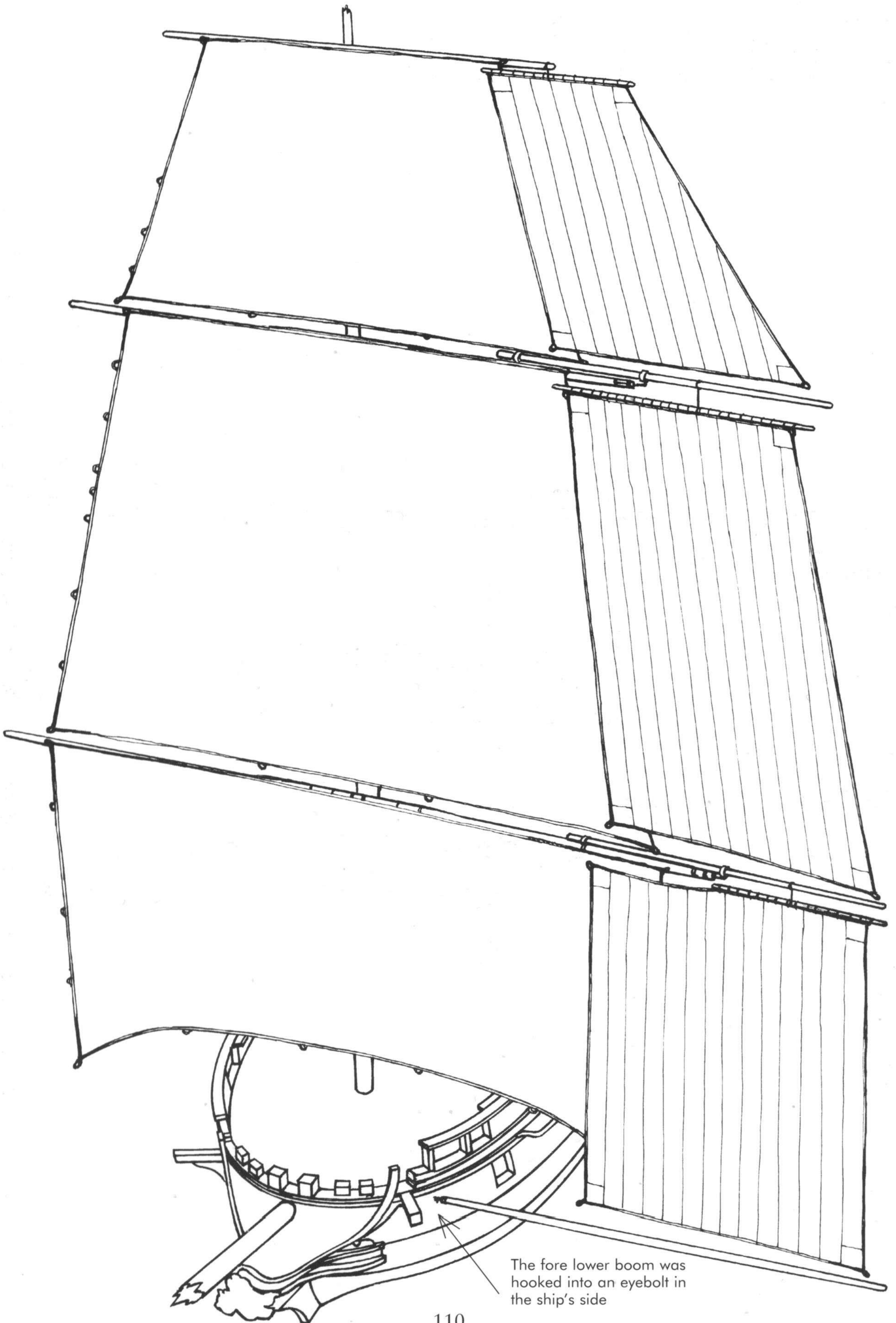

Quarter Deck

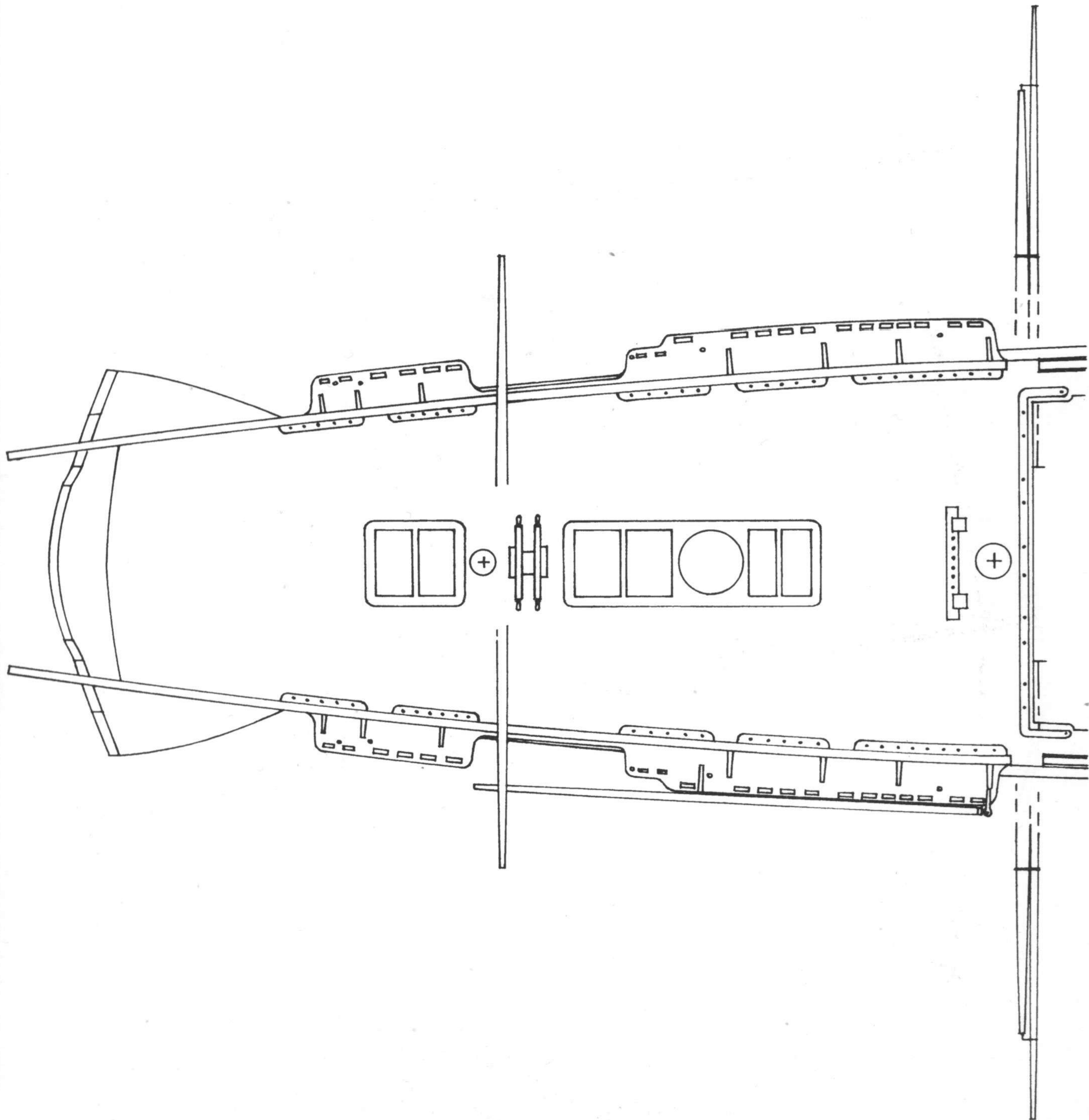

The Bow

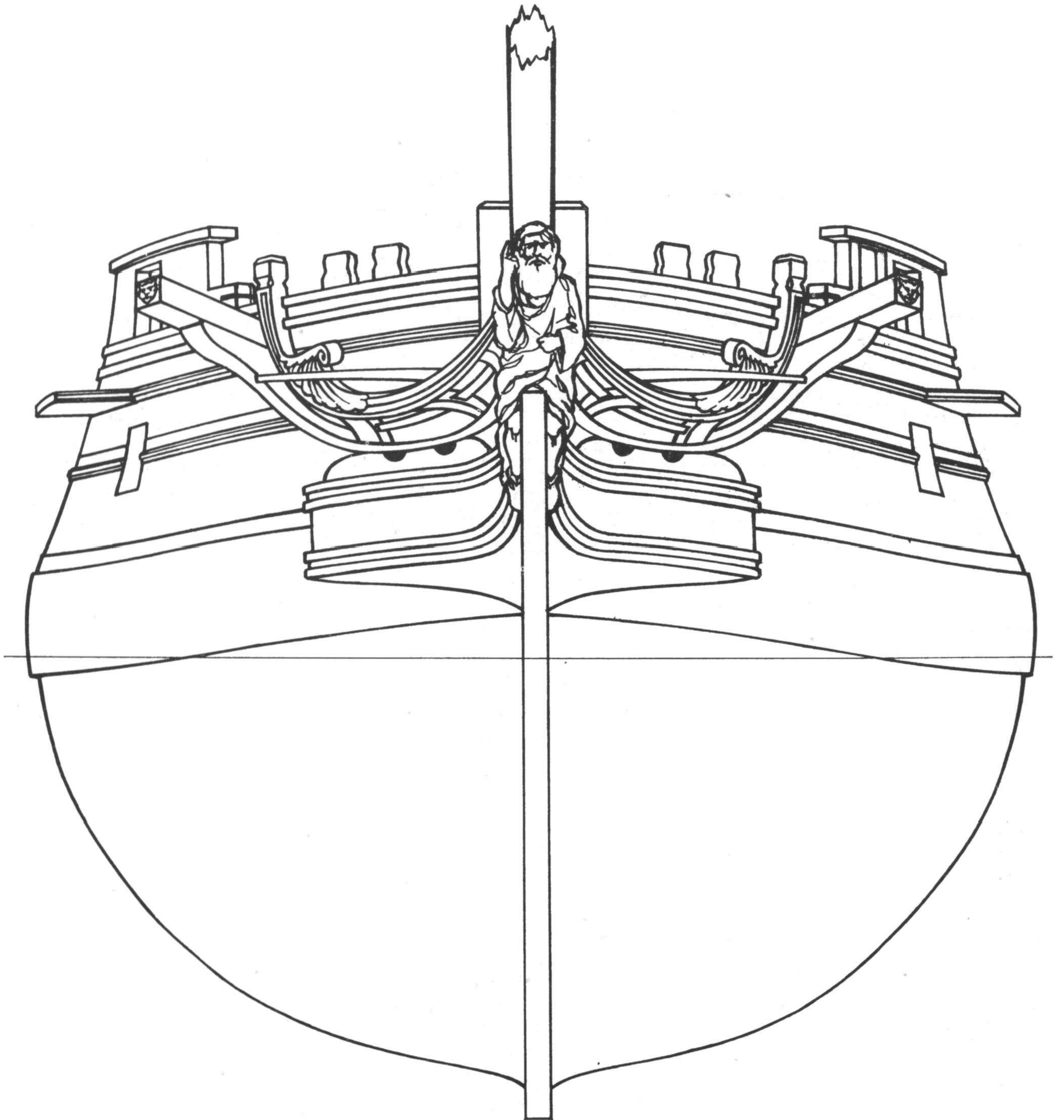

The Stern

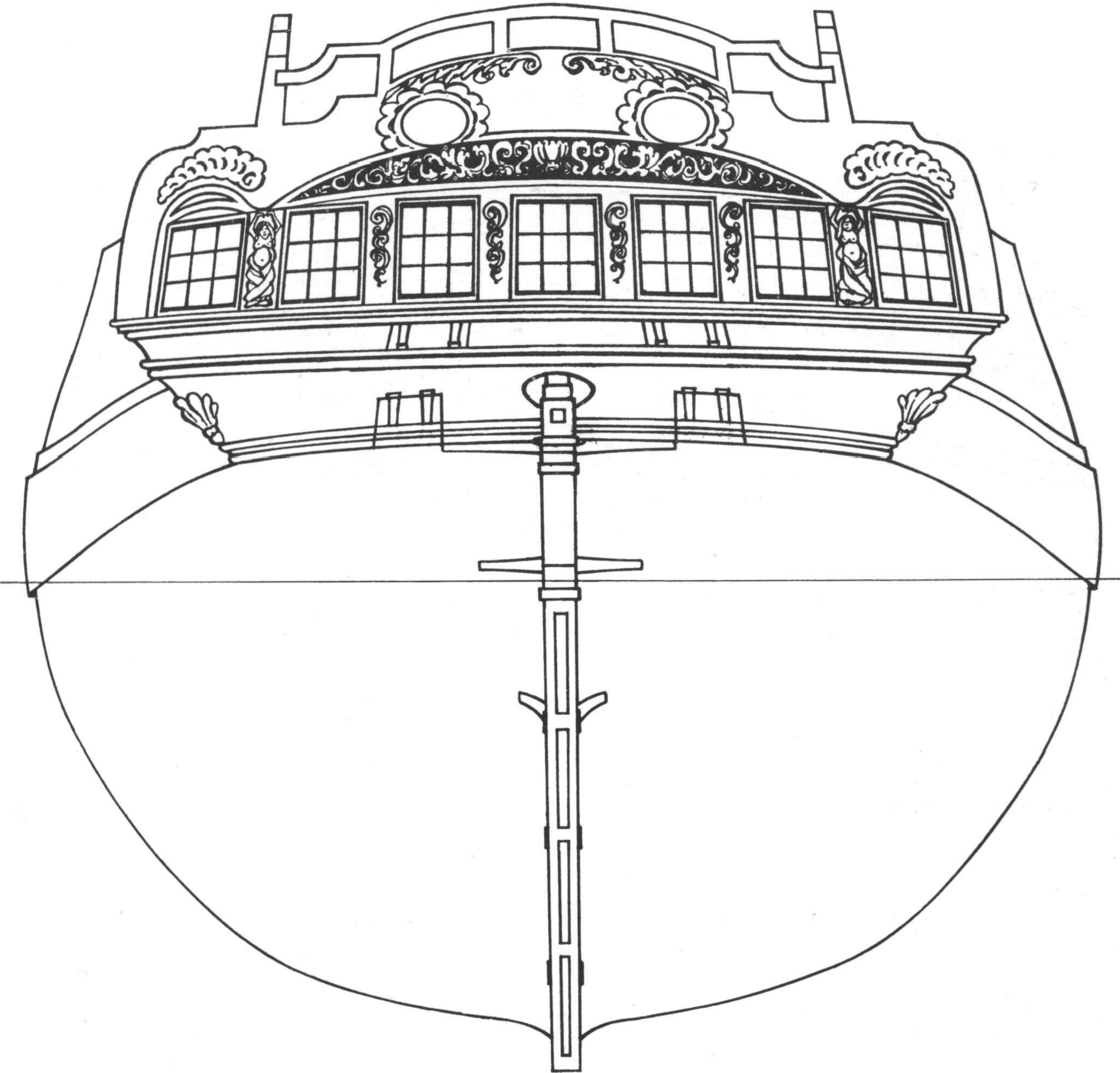

Waist & Forecastle

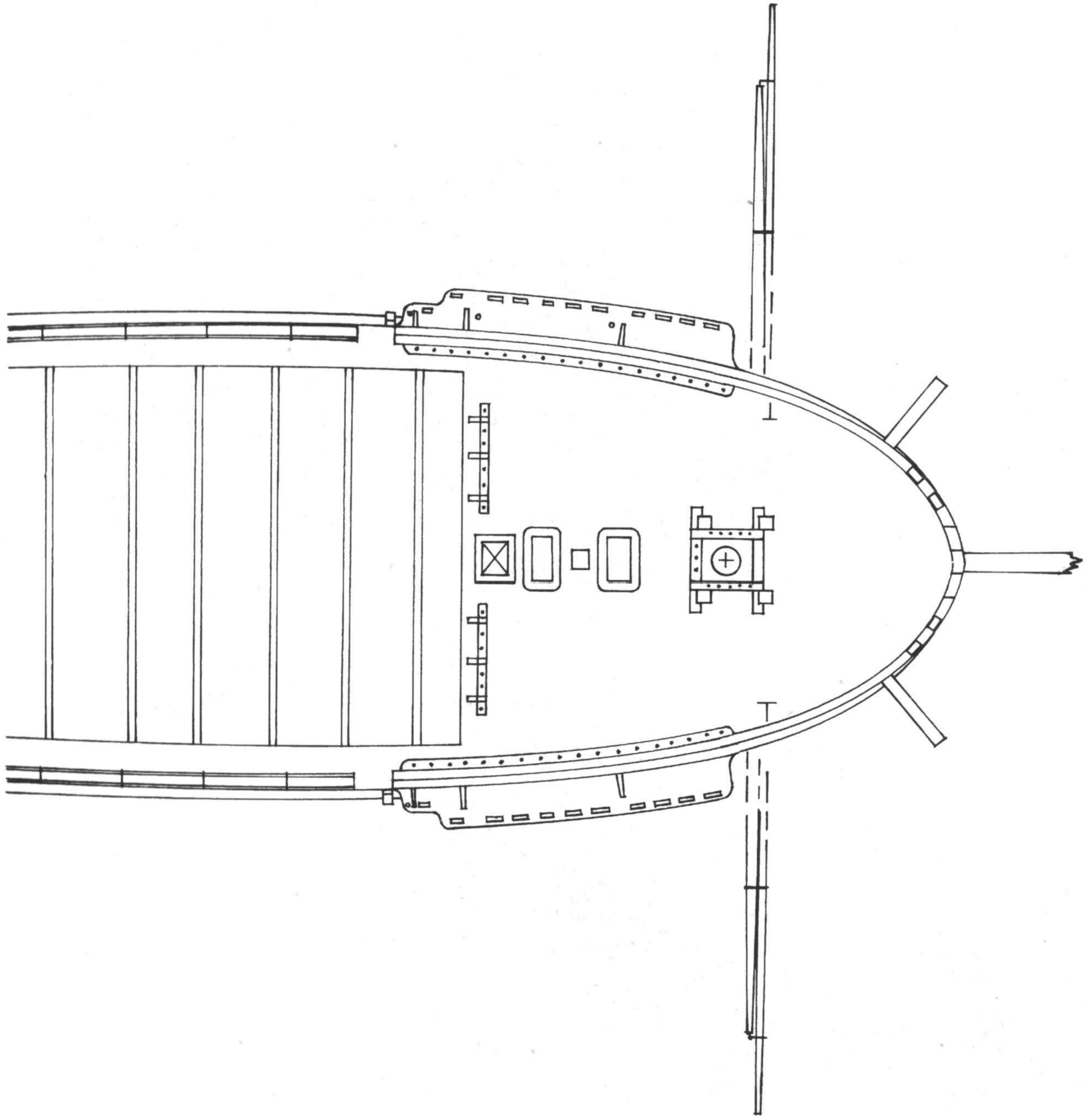

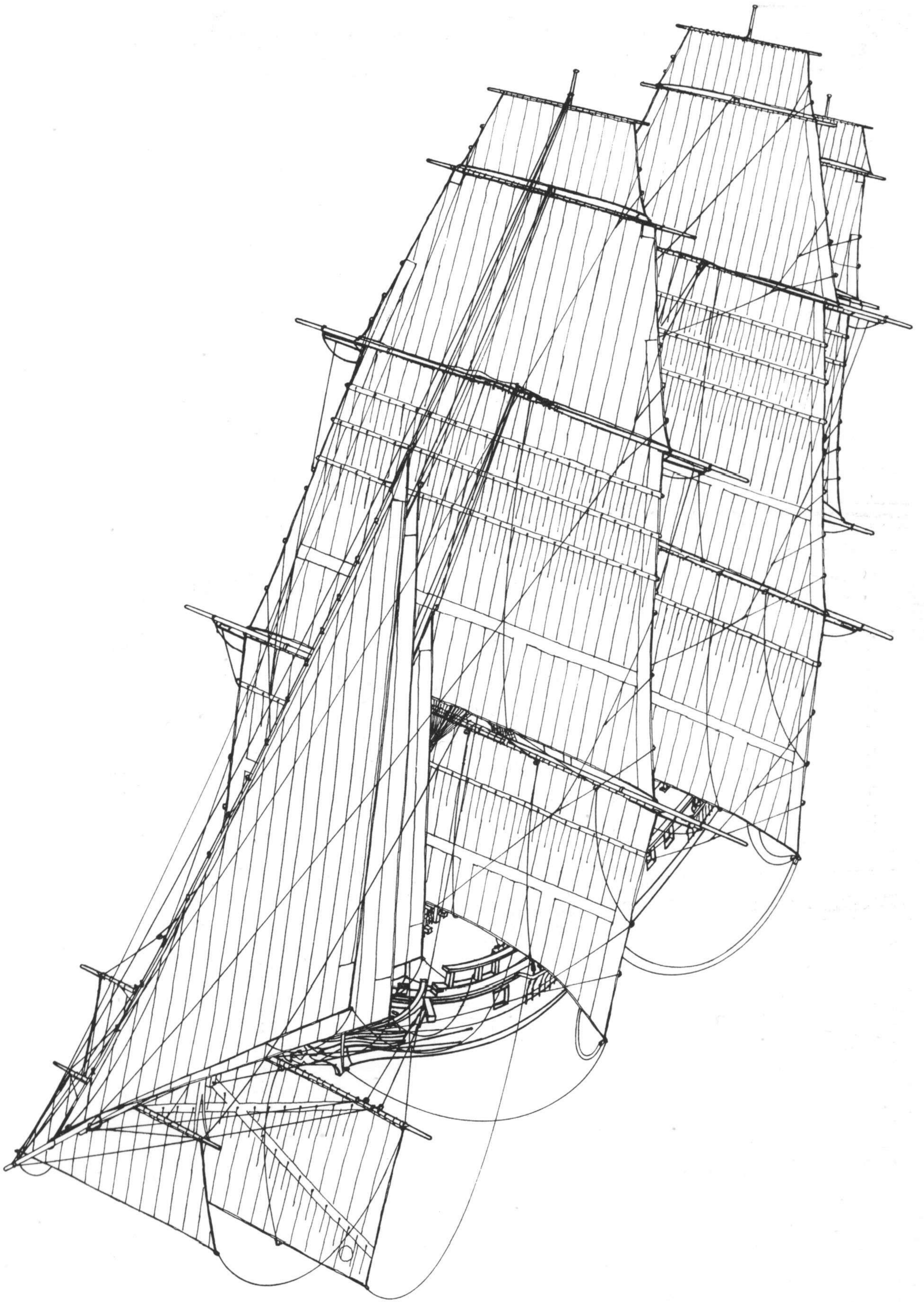

Index

	Page		Page
Backstays	8, 9, 10, 11	Cluelines, main topsail	54
Belaying points	98, 99, 100, 101	Cluelines, mizzen topgallant	57
Belfry	45	Cluelines, mizzen topsail	56
Blocks	37, 39, 43, 44, 48, 82, 83	Cluelines, spritsail	65
Bobstay	20	Cluelines, spritsail topsail	64
Boom, spanker	25	Cranes, forecastle	103
Boom, irons	86	Cranes, quarter deck	102
Boom, lower studding sail	108, 109, 110, 111	Cranes, waist	44, 103
Boom, topgallant studding sail	43, 108, 109, 110	Crossjack yard	22, 23, 24, 85
Boom, topmast studding sail	43, 108, 109, 110	Cross trees, fore mast	7, 10, 11
Bowline bridles	76	Cross trees, fore topmast	11, 19, 78
Bowlines, fore course	75	Cross trees, main mast	13
Bowlines, fore topgallant	76	Cross trees, main topmast	16, 17, 79
Bowlines, fore topsail	75	Cross trees, mizzen mast	4, 8
Bowlines, main course	77	Cross trees, mizzen topmast	28, 30
Bowlines, main topgallant	78	Deadeyes	2
Bowlines, main topsail	77	Deck, forecastle	103, 114
Bowlines, mizzen topgallant	79	Deck, quarter	102, 111
Bowlines, mizzen topsail	79	Dolphin striker	20, 21
Bowsprit, bees	20	Downhaul, flying jib	97
Bowsprit, cap	20	Downhaul, fore staysail	87
Bowsprit, shrouds	20	Downhaul, fore topmast staysail	91
Braces, crossjack	32	Downhaul, jib	96
Braces, fore royal	46	Downhaul, main staysail	88
Braces, fore topgallant	45	Downhaul, main topmast staysail	93
Braces, fore topsail	44	Downhaul, main topgallant staysail	95
Braces, fore yard	44	Downhaul, mizzen staysail	89
Braces, main royal	46	Downhaul, mizzen topmast staysail	94
Braces, main topgallant	45	End seizing	2
Braces, main topsail	43	Eye bolts	17, 36
Braces, mizzen topgallant	33	Eye seizing	2
Braces, mizzen topsail	33	Eye splice	18, 85
Braces, spritsail topsail	47	Figurehead	112
Braces, spritsail yard	47	Fittings of main yard	85, 86
Brails, spanker	81	Flemish horses	85
Bumpkin shrouds	48, 61	Flying jibboom	21, 47, 63
Buntlines, fore course	70	Flying jibboom, guys	58
Buntlines, fore topsail	71	Flying jibboom, horses	60
Buntlines, main course	72	Flying jibboom, purchase	59
Buntlines, main topsail	73	Flying jibboom, stay	19
Buntlines, mizzen topsail	74	Flying jibboom, traveller	97
Buntlines, spritsail	69	Forecastle deck	103, 114
Burton pendants	5, 6, 11, 13	Fore course rigging	48, 70, 75, 83
Catharpins	7	Fore lower mast	5, 7, 15
Channels, fore	2	Foremast crosstrees	7, 11, 18, 19
Channels, main	3	Foremast trestletrees	7, 11, 18, 19
Channels, mizzen	4	Foremast preventer stay	15
Cleat, shroud	31, 42, 94	Fore royal mast	19
Cluelines, fore topgallant	50	Fore royal stay	19
Cluelines, fore topsail	49	Fore stay	15
Cluelines, main topgallant	55	Fore topgallant mast	17, 19
		Fore topgallant stay	19

	Page
Fore topgallant yard	50, 85
Fore topmast	7, 11
Fore topmast crosstrees	11, 18, 19
Fore topmast preventer stay	18, 20
Fore topmast stay	18, 20
Fore topmast trestletrees	11, 18, 19
Fore topsail yard	85
Fore yard	35, 36, 38, 44, 48, 49, 85
Futtock shrouds	7
Futtock staves	7
Gaff, spanker	26, 27, 28, 29, 33
Grommet, mast	31
Guys, jibboom	58
Guy pendants, spanker boom	25
Guys, studding sails	109
Halliard, flying jib	97
Halliard, jib	96
Halliard, spritsail yard	59
Halliard, sprit topsail yard	59
Halliard, staysail fore	87
Halliard, staysail fore topmast	91
Halliard, staysail main	88
Halliard, staysail main topmast	93
Halliard, staysail main topgallant	95
Halliard, staysail mizzen	89
Halliard, staysail mizzen topmast	94
Hammock cranes	44, 102, 103
Hawse holes	112
Hearts	14, 15
Horse, boom	26
Horse, crossjack	85
Horse, flemish	85
Horse, flying jibboom	60
Horse, fore topgallant	85
Horse, fore topsail	85
Horse, fore yard	85
Horse, main topgallant	85
Horse, main topsail	85
Horse, main yard	85
Horse, mizzen topgallant	85
Horse, mizzen topsail	85
Horse, spritsail topsail	85
Horse, spritsail yard	85
Inner martingale	21
Inner tricing line, fore	98
Jaws, spanker boom	81
Jaws, spanker gaff	29
Jeer blocks, fore yard	35
Jeer blocks, main yard	35
Jibboom guys	58
Jibstay	19, 21

	Page
Jib traveller	21
Lanyards, lower deadeye	2
Lantern, stern	28, 104
Lashing	3, 11, 15, 23
Leech lines, fore course	70
Leech lines, main course	72
Lifts, crossjack yard	24
Lifts, fore topgallant yard	42
Lifts, fore topsail yard	42
Lifts, fore yard	38
Lifts, main yard	37
Lifts, main topgallant yard (same as fore topgallant yard)	42
Lifts, main topsail yard (same as fore topsail yard)	42
Lifts, mizzen topgallant yard	31
Lifts, mizzen topsail yard	31
Lifts, royal yard	42
Lifts, spritsail topsail yard	65
Lifts, spritsail yard	64
Lower studding sails	108, 109, 110
Main brace	43
Main jeers	35
Main mast	12, 13, 14
Main preventer stay	14
Main royal mast	9, 12
Main royal stay	12, 17
Main sheet	51
Main stay	12, 14
Main top	34, 35, 43, 44, 52, 100
Main topgallant mast	12, 17
Main topgallant stay	12, 17
Main topgallant yard	45, 55, 82, 85,
Main topmast preventer stay	12, 17
Main topsail yard	39, 43, 52, 53, 54, 67, 85
Main yard	43, 51, 52, 84, 85,
Martingales	21, 109
Middle seizing	2
Mizzen mast	4, 6, 8
Mizzen mast, crosstrees	4, 13
Mizzen mast, top	23, 24, 26, 27, 43
Mizzen mast, trestle trees	4, 13
Mizzen royal mast	8, 12
Mizzen topgallant mast	8, 12
Mizzen topgallant stay	12, 16
Mizzen topgallant yard	85
Mizzen topmast crosstrees	30
Mizzen topmast stay	12, 16
Mizzen topmast trestle trees	30
Mizzen topmast yard	30, 37, 56, 85
Nave line, fore	36

	Page		Page
Nave line, main	36	Spritsail, yard	85
Open hearts	15	Spritsail topsail, braces	47
Outer martingale	21	Spritsail topsail, cluelines	64
Outer tricing line	84	Spritsail topsail, halliard	59
Outhauler, flying jib	63, 97	Spritsail topsail, lifts	65
Outhauler, jib	62, 96	Spritsail topsail, yard	65, 85
Parcelling	15	Staves, futtock	7
Parral	40	Stay, jib	12, 19, 21
Peak, spanker gaff	27, 28	Stays, overall view	12
Peak halliard	28	Staysails	107
Pendants, burton	5, 6, 11, 13	Stern	113
Quarter deck	102, 111	Stirrups	85, 86
Ratlines	3	Studding sail boom irons	86
Reef tackle purchase, fore topsail	66	Studding sail booms	108, 109, 110, 111, 114
Reef tackle purchase, main topsail	67	Studding sail yards	108, 109, 110
Reef tackle purchase, mizzen topsail	68	Tack, fore course	48
Ringbolts	17, 36	Tack, main course	51
Royal backstays	8, 9, 10	Throat halliard, spanker gaff	29
Royal stay, fore	12, 19, 60	Topgallant mast, mizzen	8, 16
Royal stay, main	12, 17	Topgallant mast, shrouds	11
Saddle, bowsprit	20, 59, 61	Topgallant mast, stays	12, 16, 17, 19
Serving	15	Topmast, backstays	8, 9, 11
Sheet blocks, spanker	25	Topmast, shrouds	7, 11
Sheets, fore course	48	Topmast, stays	12, 16, 17, 18, 20
Sheets, fore topgallant	50	Topping lift, spanker boom	26
Sheets, fore topsail	49	Topsail sheet, fore	49
Sheets, fore royal	50	Topsail sheet, main	52
Sheets, main course	51	Topsail sheet, mizzen	56
Sheets, main topgallant	55	Traveller, flying jib	97
Sheets, main topsail	52	Traveller, jib	21
Sheets, main royal	55	Tricing line	84
Sheets, mizzen topgallant	57	Trestle trees, fore topmast	19, 78
Sheets, mizzen topsail	56	Truss pendants, crossjack	22
Sheets, mizzen royal	57	Truss pendants, fore yard	36
Sheets, spritsail	65	Tye, fore topgallant	41
Sheets, spritsail topsail	64	Tye, fore topsail	40
Shroud cleats	31, 42, 94	Tye, fore royal	41
Shrouds, bowsprit	20	Tye, main topgallant	41
Shrouds, bumpkin	61	Tye, main topsail	39
Shrouds, futtock	7	Tye, main royal	41
Shrouds, lower	2, 3, 4, 5, 6, 7, 10	Tye, mizzen topgallant	30
Shrouds, topgallant	11	Tye, mizzen topsail	30
Shrouds, topmast	7, 11	Tye, mizzen royal	30
Slings	20, 23, 34, 59	Vangs	27
Spars	85, 86	Waist	103, 114
Spritsail, braces	47	Windows, quarter gallery	6
Spritsail, buntlines	69	Windows, stern	113
Spritsail, cluelines	65	Worming	15
Spritsail, halliard	59	Yards	85, 86
Spritsail, sheets	65		

